

M20047-1

M20047-1 • RADIONOVA[®]



Features

- SMD Active GNSS antenna (GPS/GLONASS/GALILEO/BEIDOU)
- SAW filter on board
- Ultra-small SMD package; 7.0 x 7.0 x 0.9mm
- 1.5 to 3.3V supply
- Low power consumption

Contents

1.	Description	2
2.	Applications	2
3.	Part number	2
4.	Functional block diagram	3
5.	Active antenna specifications	3
5.1.	Absolute maximum ratings	3
5.2.	Recommended operating conditions	3
5.3.	DC electrical characteristics	3
5.4.	RF specifications	4
5.5.	Band rejection	4
5.6.	Mechanical specifications	4
6.	Active antenna dimension	5
7.	Schematic symbol and pin definition	5
8.	Host PCB footprint	6
9.	Active antenna application	6
9.1.	Reference schematic	6
9.2.	Active antenna performance	7
9.3.	External matching	9
9.4.	Antenna clearance	10
9.5.	Module placement guidelines	11
10.	Evaluation kit	12
11.	Reflow soldering	13
11.1.	Placement	13
11.2.	Soldering paste	13
11.3.	Soldering	13
11.4.	Multiple soldering	14
11.5.	Hand soldering	14
12.	Quality and environmental specifications	14
13.	Hazardous material regulation conformance	15
14.	Packaging	15
14.1.	Optimal storage conditions	15
14.2.	Tape characteristics	16
14.3.	Reel dimensions	17
14.4.	Box dimensions	17
14.5.	Bag properties	18
14.6.	Reel label information	18

1. Description

A compact Active GNSS antenna using a high performance LNA with SAW for optimum performance. The M20047-1 operates from a 1.5 – 3.3V supply with low power consumption. The active antenna has the SAW filter after the LNA, this minimises the overall noise, so that weaker signals can be tracked.

2. Applications

- Wearable devices
- Portable devices
- Asset tracking / Personal safety
- Sport cameras / Equipment
- Smart watches
- Navigation devices

3. Part number

M20047-1

Top view

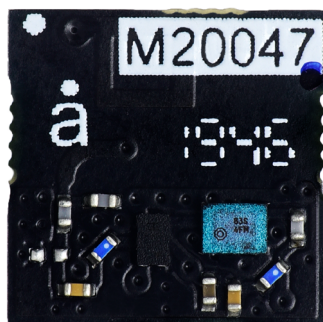

Bottom view

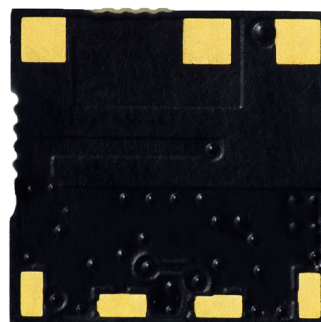

4. Functional block diagram

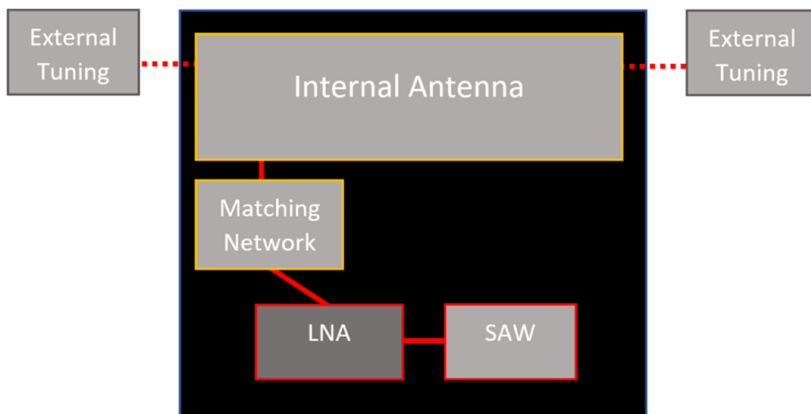

5. Active antenna specifications

5.1. Absolute maximum ratings

SYMBOL	PARAMETER	MIN	MAX	UNIT
V_{CC}	Main supply voltage	-0.3	3.6	V
RF_{IN}	Maximum RF input power	N/A	0.0	dBm
T_{STG}	Storage temperature	-40	+85	°C
T_{OP}	Operating temperature	-40	+85	°C

Exposure to absolute ratings may adversely affect reliability and may cause permanent damage.

5.2. Recommended operating conditions

SYMBOL	PARAMETER	MIN	TYP	MAX	UNIT
V_{CC}	Main supply voltage	1.5	-	3.3	V
T_{OP}	Operating temperature	-40	-	+85	°C

5.3. DC electrical characteristics

Conditions: $V_{CC} = 2.8V$, $T_{OP} = 25\text{ °C}$

SYMBOL	PARAMETER	TYP	UNIT
$I_{CC(AVG)}$	Supply current (on mode)	2.6	mA

5.4. RF specifications

Conditions: $V_{CC} = 2.8V$, $T_{OP} = 25\text{ }^{\circ}C$, Freq = 1575.420MHz

SYMBOL	PARAMETER	TYP	UNIT
Gain _{LNA}	LNA Insertion power gain	18.5	dB
NF	Noise Figure	0.9	dB
ANT _{RL}	Antenna return loss	< -10	dB
ANT _{EFF}	Antenna total efficiency	65	%

Note: All data based on Antenova EVB-1

5.5. Band rejection

FREQUENCY	STANDARD	TYP*	UNIT
698-798	LTE700	53	dB
824-849	Cellular CDMA	54	dB
869-894	GSM850	55	dB
880-915	GSM900	55	dB
1710-1785	GSM1800/DCS	40	dB
1850-1910	GSM1900/PCS	43	dB
1920-1980	WCDMA	38	dB
2400-2492	WLAN, BT and WiMAX	33	dB
2500-2690	LTE2600	33	dB

Note: Does not include antenna rejection.

5.6. Mechanical specifications

PARAMETER	TYP	UNIT
Active antenna exterior dimensions (L x W x H)	7.0 (±0.1) x 7.0 (±0.1) x 0.9 (±0.2)	mm
Active antenna support and connection	Surface mounted (SMD)	-
Active antenna mass	≤0.2	g

6. Active antenna dimension

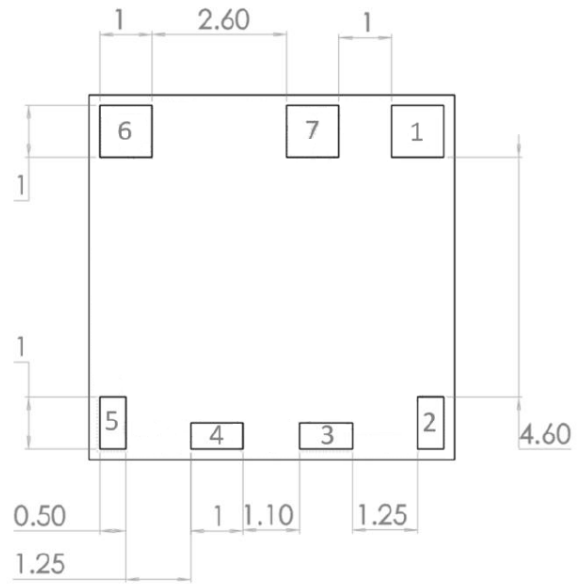
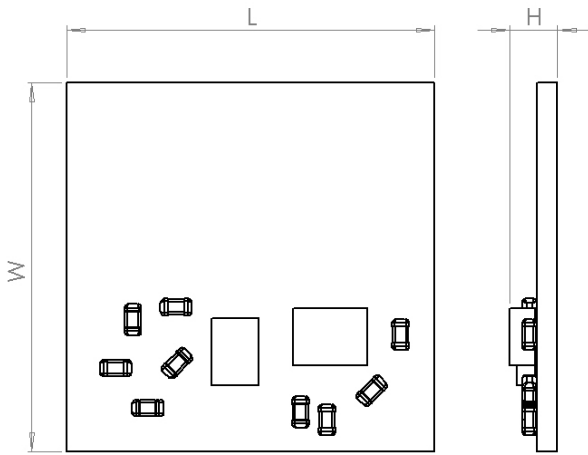

Pads 1, 6, 7 = 1.0 x 1.0 (mm)
 Pads 2, 3, 4, 5 = 1.0 x 0.5 (mm)

L	W	H
Length	Width	Height
7.0 ±0.1	7.0 ±0.1	0.9 ±0.2

All dimensions in (mm)

7. Schematic symbol and pin definition

PIN	DESIGNATOR	DESCRIPTION
1	AT1	Antenna tuning left side
2	GND	Ground connection
3	GND	Ground connection
4	GND	Ground connection
5	RFO/VCC	RF signal output / DC voltage input
6	AT2	Antenna tuning right side
7	NC	Not connected

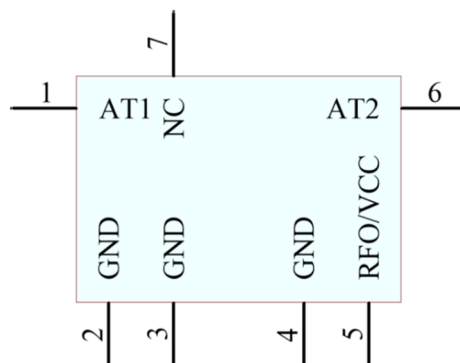

8. Host PCB footprint

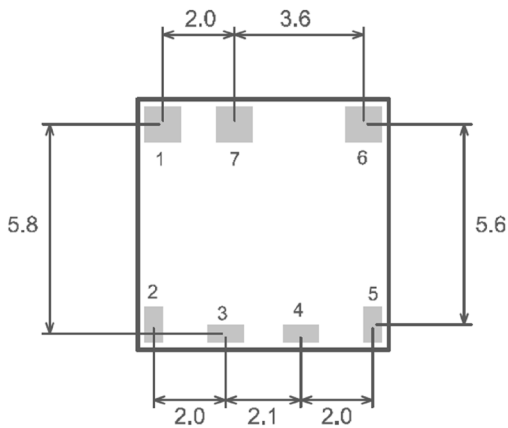

All dimensions in (mm)

9. Active antenna application

9.1. Reference schematic

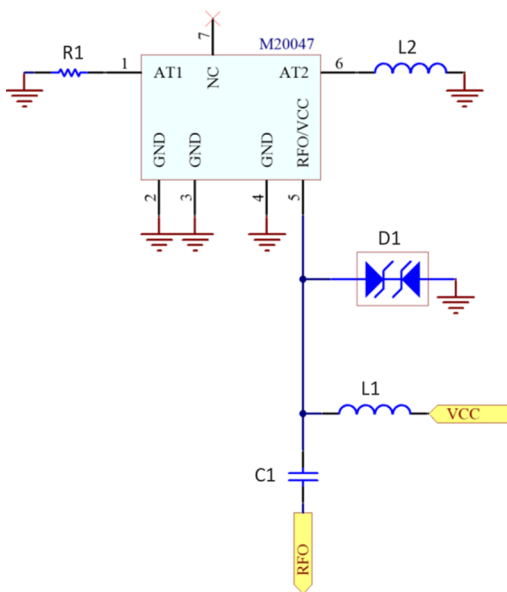

Bill of Material

DESIGNATOR	VALUE	DESCRIPTION / COMMENTS	QUANTITY
D1	ESD diode	TVS 20kV ESD protection (Non-specific)	1
L1	47nH inductor	RF choke	1
C1	22pF capacitor	DC blocking capacitor	1
L2	1.8nH inductor	Antenna tuning (value dependent on host PCB)	1
R1	0 ohm	For additional antenna tuning	1

9.2. Active antenna performance

9.2.1. Antenna return loss

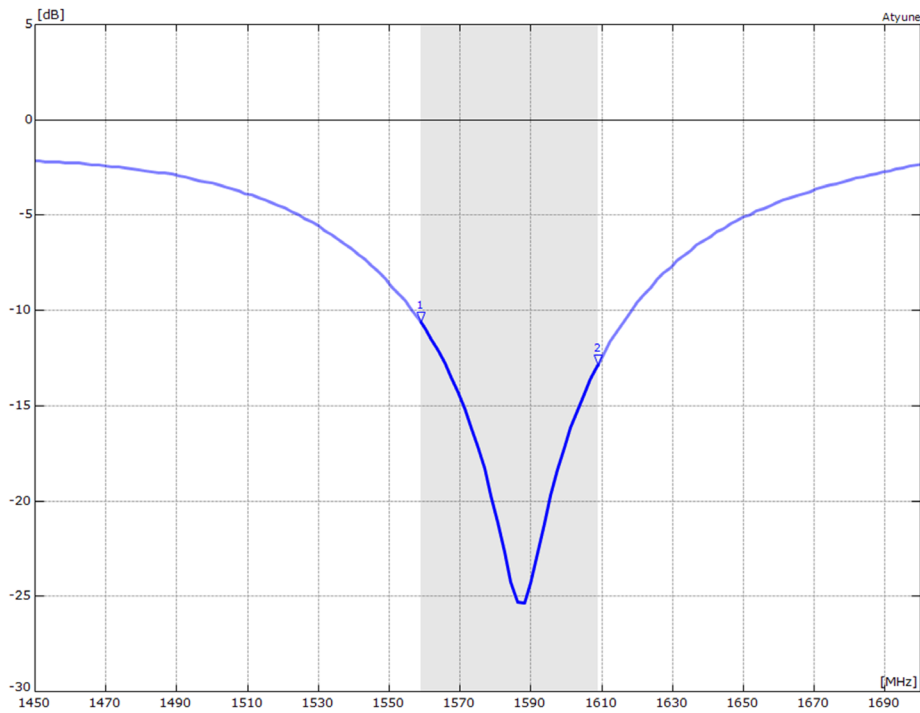

9.2.2. Antenna VSWR

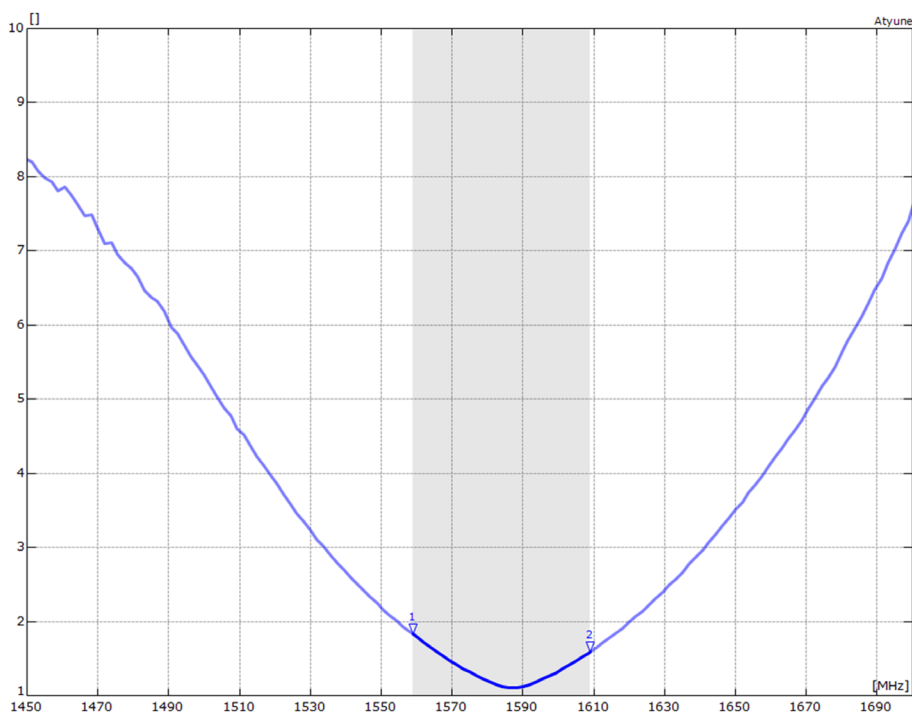

9.2.3. Antenna pattern

Antenna pattern 1559 MHz - 1609 MHz

3D pattern at 1575MHz



XY

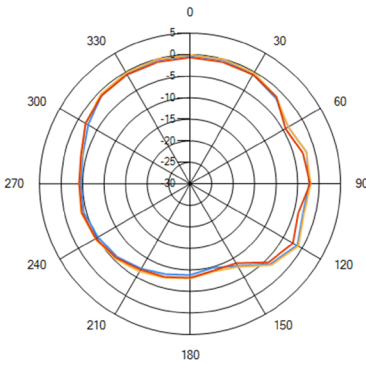

XZ

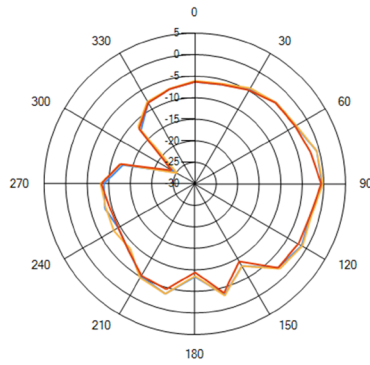

YZ

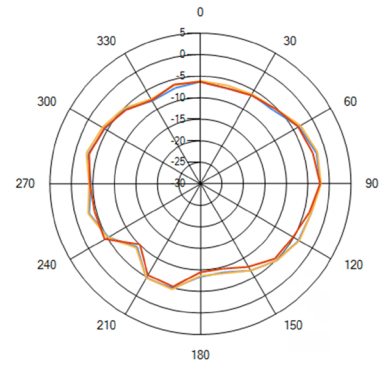

— 1.559GHz — 1.575GHz — 1.609GHz

9.3. External matching

The M20047-1 active antenna uses external matching circuit components on the host PCB to fine-tune the antenna to each specific application. This “external matching” allows compensating for the detuning of the antenna caused by various components that can be close to the M20047-1 in the actual application (plastic case, battery, speakers, etc).

The external matching must be placed on the host PCB as close as possible to the active antenna pads AT1 (Pad1) and AT2 (Pad6), respectively. A single matching component for each pin is required. A perfect GND plane connecting for each matching component is needed. For multi-layer PCB, an individual GND via should be placed close to the matching component as possible.

Schematic: See below based on Antenova EVB-1: AT1 uses a 0ohm resistor and AT2 uses a 1.8nH inductor to tune the antenna. Provision must be made for these components in as they will be required to optimise the antenna performance for your PCB – please see the Antenova website [Support \(Services\)](#) section for details on how we can support you to select these components.

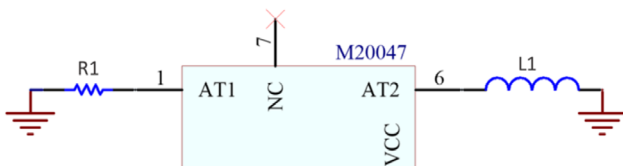

Type of Matching Components:

- Capacitors: Use 0402, COG components
- Inductors:
 - High-Q, wire wound inductors in 0402 sizes are recommended for maximum performance, e.g. Murata LQW15 series.
 - Good quality multi-layer type inductors (e.g. Murata LQG15 series) can also be used as a lower cost alternative.

9.4. Antenna clearance

The M20047-1 active antenna requires a clearance on the host PCB to operate. The clearance means that no ground or tracks of any kind can be placed within this area. This clearance area also needs to be applied through the entire PCB stack up. The minimum area needed for clearance is 7.0mm x 5.0mm.

Top view of M20047-1 host PCB footprint

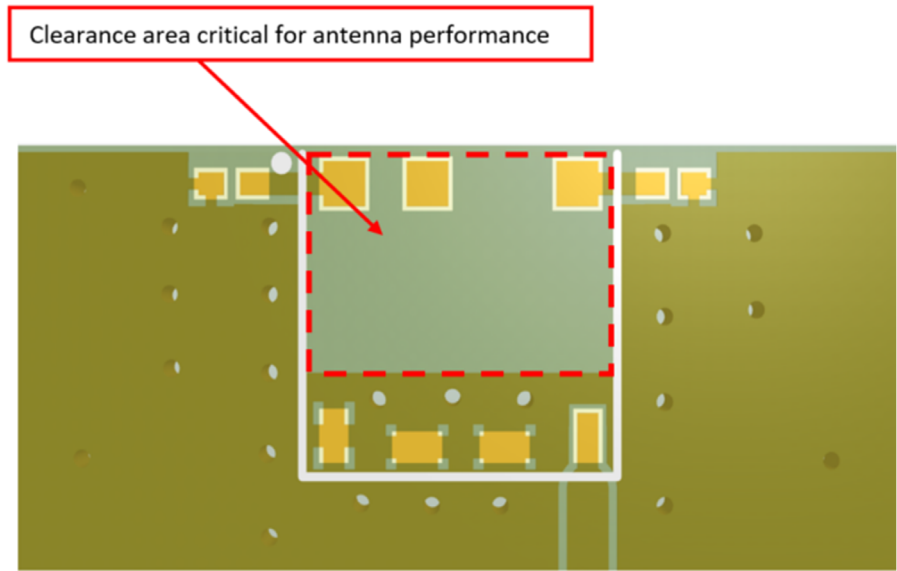
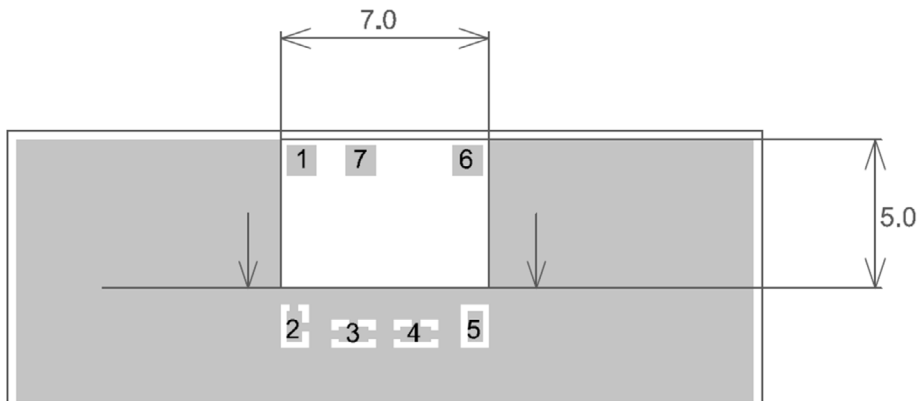

9.5. Module placement guidelines

For the M20047-1 active antenna, care must be taken when defining the placement of the module on the host PCB. Here are some guidelines that should be used when deciding the position of the module.

- The active antenna top edge should be placed almost level with the centre of the LONG edge of the host PCB.
- The edge of the host PCB that the active antenna is to be placed should be a minimum of 40mm in length. Shorter PCB lengths maybe possible, depending on your device and performance requirements, please visit ask.antenova.com for more detailed guidance.
- Central placement of the active antenna is advised. However, an offset placement is also possible.
- For an offset closer to the PCB edge to the right side of the active antenna, a minimum of 10mm distance is required to the edge of the host PCB (see example, right, based on the EVK).
- The active antenna uses the host PCB ground to effectively radiate. As such, a GND plane must be placed on the host PCB on at least one layer.
- In this example, the only area void of GND is the antenna keep-out area. The solder mask is removed to make the copper visible.
- An ideal stack-up for a host PCB would be to use the top and bottom layers as GND planes, while using the internal layers for any signal and power planes. This not only helps the GPS antenna to perform effectively, but also helps to reduce any potential noise issues that can be associated with mixed signal PCB's.
- The example on the right shows a 4-layer host PCB. For GND layer, all available space should not be used for signal trace routing or component placement.

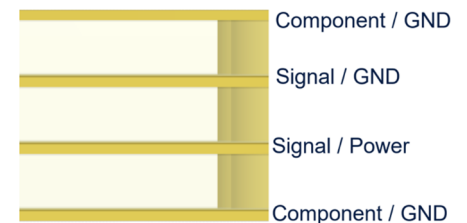
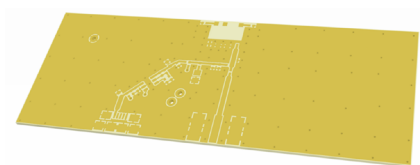
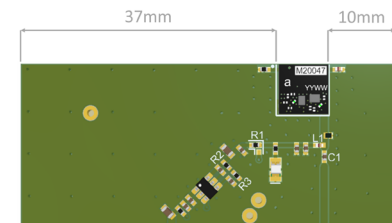
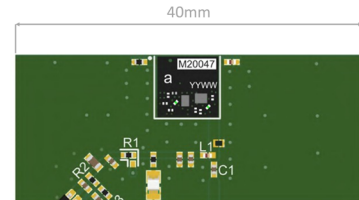

10. Evaluation kit

The EVK is a single PCB that contains the M20047-1 active antenna and required components to run on a PC via a USB cable and Antenova software. Evaluation kits are available on request. Please contact Antenova for more information. (Part number: M20047-EVB-1).

To order a reference board please see antenova.com

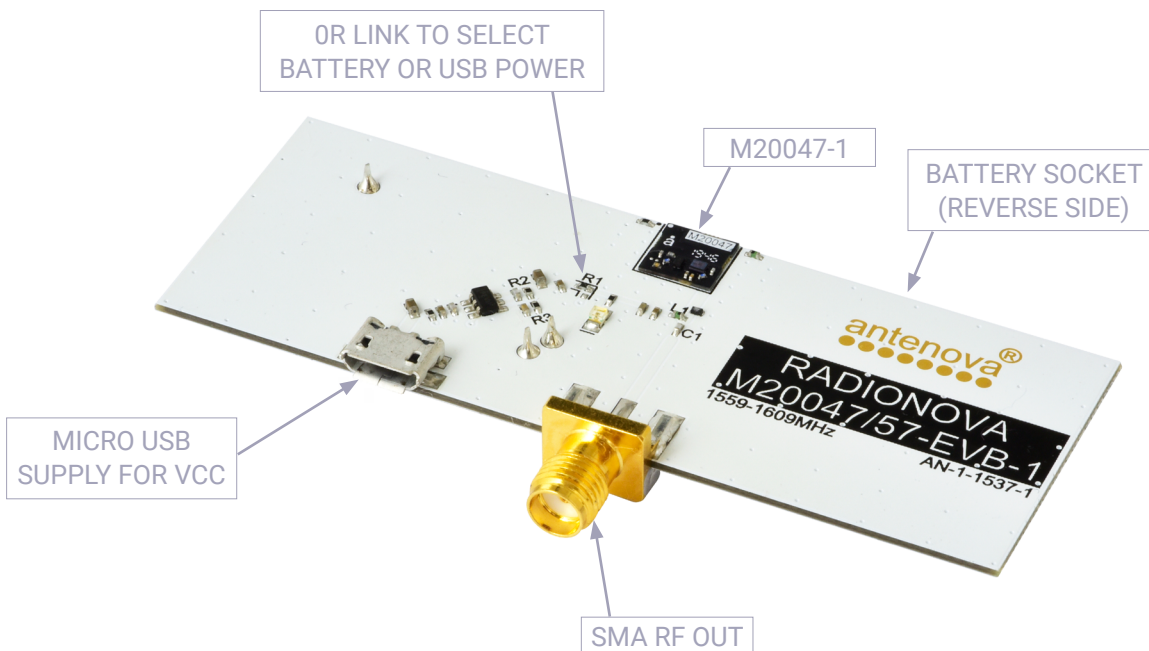
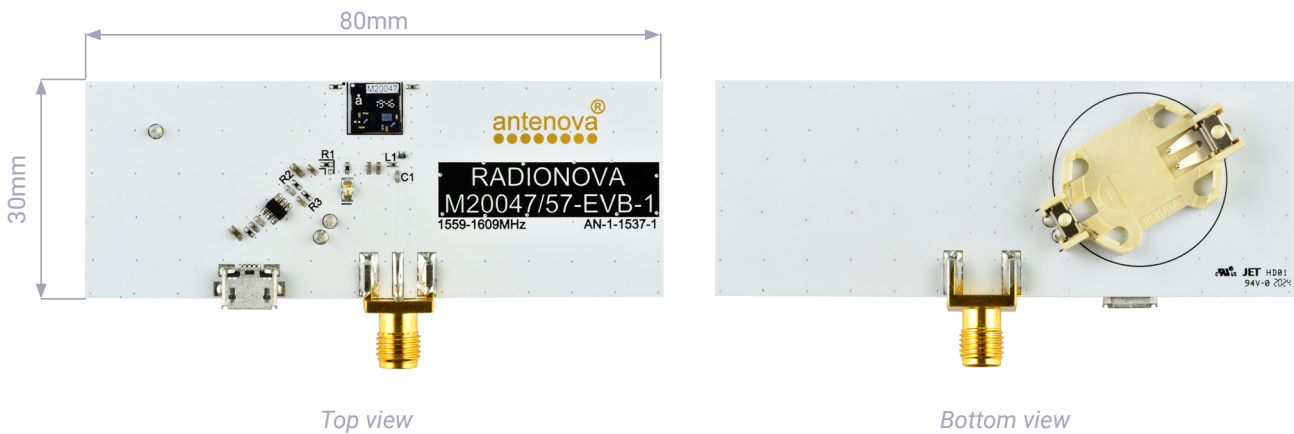

11. Reflow soldering

11.1. Placement

Typical placement systems used for any BGA/LGA package are acceptable.
 Recommended nozzle diameter for placement: 5mm

11.2. Soldering paste

Use of "No Clean" soldering paste is strongly recommended, as it does not require cleaning after the soldering process has taken place. An example of suitable soldering paste is Alpha OM350.

11.3. Soldering

The recommended soldering profile for M20047-1 active antenna is shown below. However, it is the responsibility of the Contract Manufacturer to determine the exact reflow profile used, taking into consideration the parameters of the host PCB, solder paste used, etc.

PROFILE FEATURE		PB-FREE SOLDER
Pre-Heat	Temperature (T_s) Min	130°C
	Temperature (T_s) Max	220°C
	Time (t_s)	<150s
Reflow	Liquidus Temperature - (T_l)	220°C
	Time (t_l)	45-90s
Peak Package Body Temperature (T_p)		245°C
Time within 5°C of peak temp (t_p)		30s
Average Ramp up rate - $T_s(\text{max})$ to (T_p)		3°C/s
Ramp Down Rate		6°C/s max

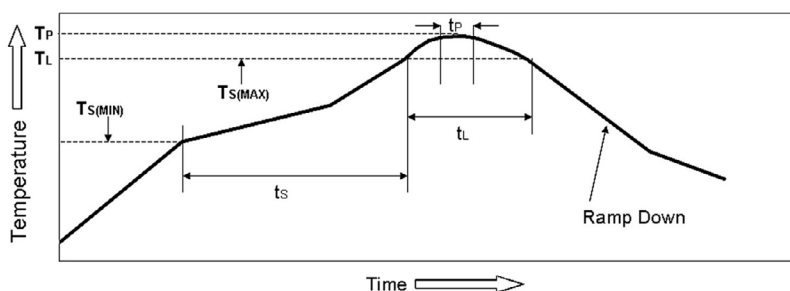

The Pb Free Process-Package Peak Reflow Temperature is 260°C.
 Exceeding the maximum soldering temperature could permanently damage the module.

11.4. Multiple soldering

The M20047-1 active antenna can be submitted up to 2 reflow soldering processes.

Upside-down soldering is acceptable but it is recommended that the Contract Manufacturer qualify the process before mass production. The second reflow must take place within the recommended floor life limit (MSL3). Please contact Antenova for further information.

11.5. Hand soldering

Hand-soldering and rework of the M20047-1 active antenna is acceptable, however care must be taken to avoid short circuits due to the small size of the module pads.

12. Quality and environmental specifications

TEST	STANDARD	PARAMETERS
PCB inspection	IPC-6012B, Class 2. Qualification and Performance Specification for Rigid Printed Boards - Jan 2007	
Assembly inspection	IPC-A-610-D, Class 2 "Acceptability of electronic assemblies"	
Temperature range	ISO16750-3	-30 °C, +25 °C, +85 °C, operating
Moisture/Reflow sensitivity	IPC/JEDEC J-STD-020D.1	MSL3
Storage (Dry Pack)	IPC/JEDEC J-STD-033C	MSL3
Solderability	EN/IEC 60068-2-58 Test Td	More than 90% of the electrode should be covered by solder. Solder temperature 245 °C ± 5 °C

Moisture sensitivity:

Antenova ships all devices dry packed in tape on reel with desiccant and moisture level indicator sealed in an airtight package. If on receiving the goods the moisture indicator is pink in colour or a puncture of the airtight seal packaging is observed, then follow J-STD-033 "Handling and Use of Moisture/Reflow Sensitive Surface Mount Devices".

13. Hazardous material regulation conformance

The RF antenna module has been tested to conform to RoHS and REACH requirements. A certificate of conformance is available from Antenova's website.

14. Packaging

14.1. Optimal storage conditions

TEMPERATURE	-10°C to 40°C
HUMIDITY	Less than 75% RH
SHELF LIFE	24 Months
STORAGE PLACE	Away from corrosive gas and direct sunlight
PACKAGING	Reels should be stored in unopened sealed manufacturer's plastic packaging.
MSL LEVEL	3

Note: The M20047-1 active antenna meet MSL Level 3 of the JEDEC specification J-STD-020D - 168 hours Floor Life (out of bag) ≤30 °C/60% RH. If the stated floor life expires prior to reflow process then follow J-STD-033 "Handling and Use of Moisture/Reflow Sensitive Surface Mount Devices".

The shelf life of the antenna is 2 years provided the factory seal on the package has not been broken.

14.2. Tape characteristics

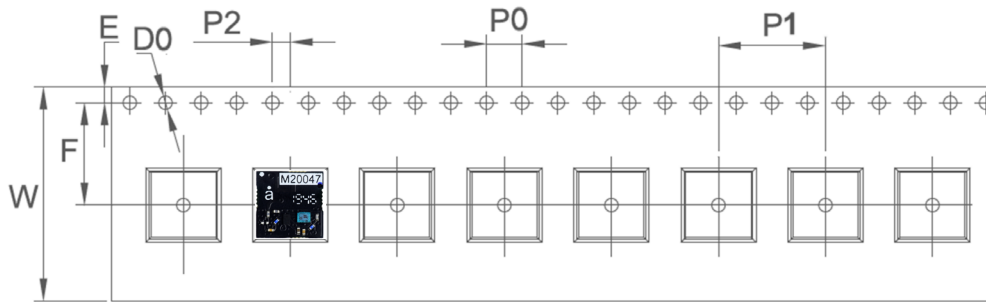

Direction of feed

P0	P1	P2	D0
4.00 ± 0.1	12.00 ± 0.1	2.00 ± 0.1	1.55 ± 0.1

E	F	W
1.75 ± 0.1	11.50 ± 0.1	24.00 ± 0.3

All dimensions in (mm)

QUANTITY	LEADING SPACE	TRAILING SPACE
1000 pcs / reel	50 blank module holders	50 blank module holders

14.3. Reel dimensions

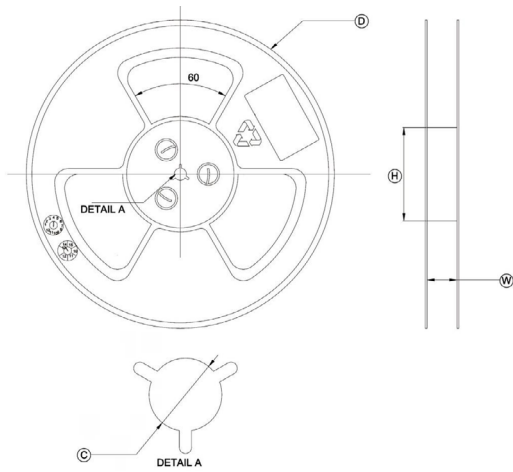

D	C	H	W
330.0 ± 2.0	13.3 ± 0.3	100.0 ± 3.0	24.5 ± 0.2

All dimensions in (mm)

14.4. Box dimensions

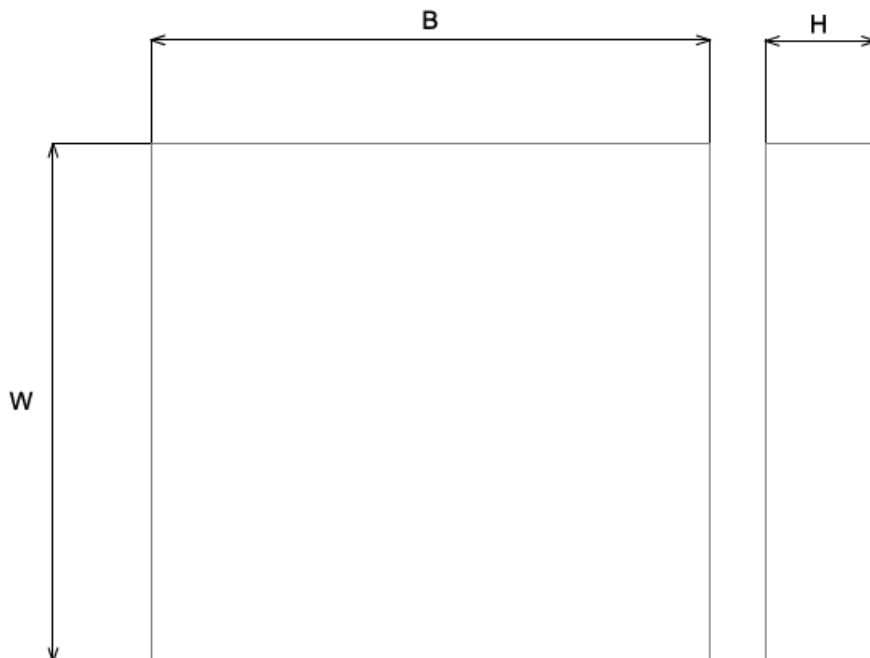

WIDTH (W)	BREADTH (B)	HEIGHT (H)
340mm	339mm	53mm

14.5. Bag properties

Reels are supplied in protective plastic packaging.

14.6. Reel label information

<p>antenva[®] Antenva Limited</p> <p>4F, No.324, Sec.1, Nei-Hu Road, Nei-Hu Dist., Taipei City 11493, Taiwan R.O.C. sales@antenva.com / www.antenva.com</p> <p>Description: GPS Module Part Number: M20047-1 Qty: 1000pcs Date Code: Package Code:</p> <p style="text-align: right;">RADIONOVA[®]</p>	<div style="display: flex; justify-content: space-between; align-items: center;"> <div style="text-align: center;">  <p>Caution This Bag Contains MOISTURE SENSITIVE DEVICES</p> </div> <div style="border: 1px solid black; padding: 5px; text-align: center;"> <p>LEVEL</p> <p style="font-size: 24px;">3</p> </div> </div> <ol style="list-style-type: none"> 1. Calculated shelf life in sealed bag: 12months at <40°C and <90% relative humidity (RH). 2. After bag is opened, devices that will be subjected to reflow solder or other high temperature process must: <ol style="list-style-type: none"> a) Mounted within: 168 hours of factory conditions <30°C/60% RH, or b) Stored per J-STD-033 3. Devices required bake, before mounting if: <ol style="list-style-type: none"> a) Humidity indicator card reads >10% when read at 23±5°C b) 2a or 2b not met 4. If baking is required, refer to IPC/JEDEC J-STD-033 for bake procedure. Note: Level and body temperature defined by IPC/JEDEC J-STD-020
--	--

Quality statements

Antenva’s products conform to REACH and RoHS legislation. For our statements regarding these and other quality standards, please see antenva.com.



Antenva reserves all rights to the contents of this document. Antenva gives no warranties based solely on the accuracy or completeness of the contents of this document and reserves the right to make changes to the specifications of the products described herein at any time and without notice.

Datasheet version

- 2.01 released Aug 31th 2021
- 2.02 released Feb 20th 2022
- 2.03 released May 10th 2022

Antenna design, integration and test resources

Product designers – the details contained in this datasheet will help you to complete your embedded antenna design. Please follow our technical advice carefully to obtain optimum antenna performance.

We aim to support our customers to create high performance wireless products. You will find a wealth of design resources, calculators and case studies to aid your design on our website.

Antenova's design laboratories are equipped with the latest antenna design tools and test chambers. We provide antenna design, test and technical integration services to help you complete your design and obtain the required certifications.

If you cannot find the antenna you require in our product range, please contact us to discuss creating a custom antenna to meet your exact requirements.

Share knowledge with **RF experts** around the world.

ask.antenova is a global forum for designers and engineers working with wireless technology.

[VISIT ASK.ANTENOVA](https://www.antenova.com/ask)

Visit [antenova.com](https://www.antenova.com)

Order antenna samples and evaluation boards, and read our antenna resources

[VISIT ANTENOVA.COM](https://www.antenova.com)

Request a volume quotation for antennas:

sales@antenova.com

Global headquarters

Antenova Ltd, 2nd Floor Titan Court, 3 Bishop Square, Hatfield, AL10 9NA

+44 (0) 1707 927589

Mouser Electronics

Authorized Distributor

Click to View Pricing, Inventory, Delivery & Lifecycle Information:

[Antenova:](#)

[M20047-1](#) [M20047-EVB-1](#)