

CMX975 2.7GHz Tx/Rx Mixers, LNA, RF Frac-N Synth, IF Integer-N Synth + VCOs

D/975/3 December 2019

DATASHEET

Provisional Information

Features

- 1 to 2.7 GHz Up/Down-converter
 - Configurable image reject or normal mode Rx mixer
 - Configurable sideband suppression or normal mode Tx mixer
 - Combine with CMX973 to implement RF-to-I/Q transceiver
 - 1 to 2.7 GHz RF / 10 to 500 MHz IF
- Integrated LNA
 - 1.7dB noise figure at 1.5GHz
 - 18dB programmable gain range
- RF synthesiser/PLL
 - Fractional-N 24-bit divider
 - Output range 350MHz – 3.6GHz
 - Programmable output divider
 - Fast lock function
 - Programmable charge pump current
- IF synthesiser/PLL
 - Integer-N 14-bit divider
 - Output range 31MHz – 1GHz
 - Programmable output divider
- -209dBc/Hz normalised phase noise
- Integrated low noise LDO regulator
- Single 2.7V to 3.6V supply
- 1.8V digital interface supported
- C-BUS configurable
- -40° to +85° operating temp. range
- Small outline 6mm x 6mm VQFN package

Applications

- L-Band / S-Band satcom
- Military radio
- Wireless microphone
- 2.4GHz ISM transceiver
- Wireless modem
- General purpose RF / IF

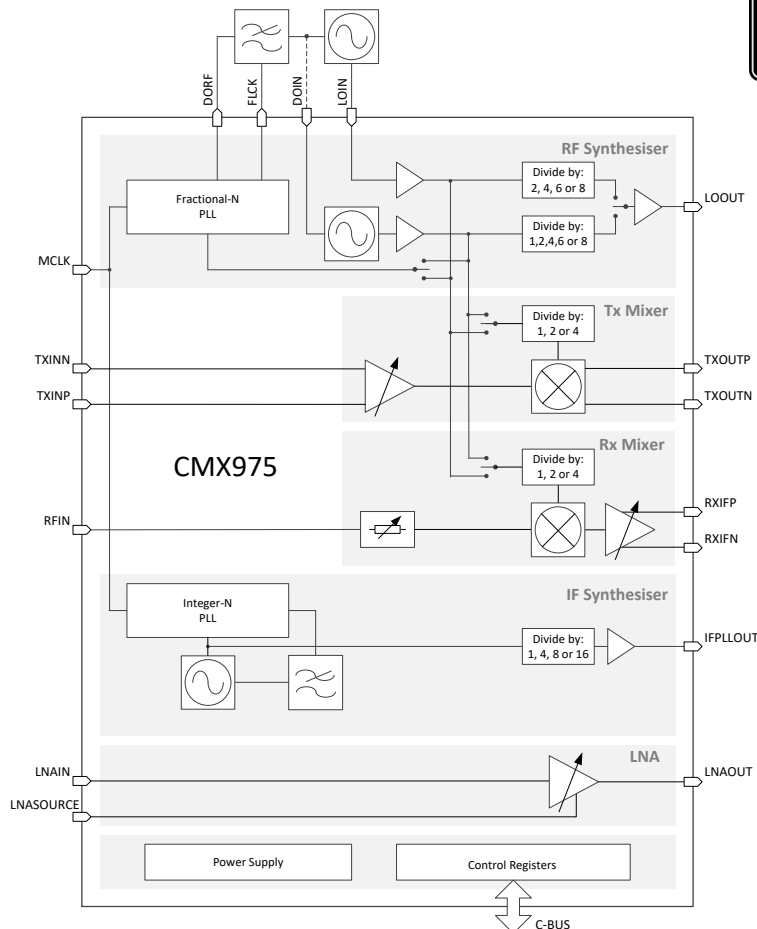

1 Brief Description

The CMX975 is an RF building block IC that provides multiple functions consisting of: RF PLL/VCO, IF PLL/VCO, Transmit Up-convert mixer, Rx Down-convert mixer, and LNA.

The RF high frequency synthesiser employs a Fractional-N design and will operate at up to 3.6GHz using a fully-integrated internal VCO or at up to 6GHz with an external frequency source. The IF synthesiser employs an integer-N design and will operate at up to 1GHz. It has an integrated VCO requiring only an external inductor to set the frequency. Internal dividers and buffers are provided for each synthesiser/PLL allowing a wide range of frequency generation options.

The Rx mixer can be configured in image reject or normal mode and the Tx mixer can be configured in sideband suppression or normal mode. The integrated LNA offers 18dB of gain reduction in three steps of 6dB.

The CMX975 has been designed to work with CML's CMX973 Quadrature Modulator/Demodulator to provide a simple and cost effective high-frequency superhet transceiver operating in the range 1 to 2.7 GHz. The device operates from a single supply voltage and is available in a small 6x6mm VQFN package.

CONTENTS

<u>Section</u>	<u>Page</u>
1 Brief Description	2
1.1 History	5
2 Block Diagram	6
3 Performance Specification	7
3.1 Electrical Performance	7
3.1.1 Absolute Maximum Ratings	7
3.1.2 Operating Limits	7
3.1.3 Operating Characteristics	8
4 Pin and Signal Definitions	18
4.1 Pin List	18
4.2 Signal Definitions	19
5 Power Supply and Decoupling	20
6 Layout Recommendations	21
7 Detailed Description	22
7.1 Power Management	22
7.2 Clock Generator	22
7.3 Tx (Up-conversion) Mixer	22
7.3.1 Matching Circuits	25
7.4 Rx (Down-conversion) Mixer	27
7.4.1 Matching Circuits	29
7.5 Low Noise Amplifier (LNA)	31
7.5.1 LNA S-parameters	31
7.5.2 Matching Circuits	32
7.6 RF VCO and Fractional-N PLL	33
7.6.1 RF Fractional-N Synthesiser	33
7.6.2 Register Loading Order	34
7.6.3 Fractional-N Programming Example	34
7.6.4 Loop Filter	35
7.6.5 RF VCO	36
7.7 IF PLL and VCO	37
7.7.1 IF PLL	37
7.7.2 Programming Example	38
7.7.3 IF VCO	38
7.7.4 IF PLL Output	40
7.7.5 IF PLL Divider	40
7.8 Local Oscillator (LO)	41
7.8.1 LO Input (LOIN)	43
7.8.2 LO Output (LOOUT)	43

7.8.3	Dividers and LO Output	44
7.9	Status and Interrupts	45
8	Register Description and C-BUS Interface	46
8.1	General Reset Command	47
8.1.1	GEN_RST - \$30	47
8.2	General Control Register	47
8.2.1	GCR - \$31	47
8.2.2	GCR_RD - \$C1	48
8.3	Rx Control Register	48
8.3.1	RX_CON - \$32	48
8.3.2	RX_CON_RD - \$C2	49
8.4	Tx Control Register	49
8.4.1	TX_CON - \$33	49
8.4.2	TX_CON_RD - \$C3	49
8.5	RF PLL	50
8.5.1	RFPLL_CON - \$34	50
8.5.2	RFPLL_BLEED - \$35	50
8.5.3	RFPLL_LOCKDET - \$36	51
8.5.4	RFPLL_FLCK - \$37	51
8.5.5	RFPLL_RDIV - \$38	52
8.5.6	RFPLL_IDIV - \$39	52
8.5.7	RFPLL_FDIV0 - \$3A	53
8.5.8	RFPLL_FDIV1 - \$3B	53
8.5.9	RFPLL_RDIV_RD - \$C8	53
8.5.10	RFPLL_IDIV_RD - \$C9	54
8.5.11	RFPLL_FDIV0_RD - \$CA	54
8.5.12	RFPLL_FDIV1_RD - \$CB	54
8.6	IF PLL	54
8.6.1	IFPLL_NDIV - \$3C	54
8.6.2	IFPLL_RDIV - \$3D	54
8.6.3	IFPLL_CURRENT - \$3E	55
8.6.4	IFPLL_NDIV_RD - \$CC	55
8.6.5	IFPLL_RDIV_RD - \$CD	55
8.6.6	IFPLL_CURRENT_RD - \$CE	55
8.7	VCO Calibration	55
8.7.1	VCO_CAL_CTRL - \$50	55
8.7.2	VCO_BIAS_CAL_WRITE - \$51	56
8.7.3	VCO_BIAS_CAL_TIME - \$52	56
8.7.4	RFVCO_CAL_WRITE - \$53	56
8.7.5	RFVCO_CAL_COUNT - \$54	57
8.7.6	RFVCO_CAL_TIME - \$55	57
8.7.7	RFVCO_STARTUP_TIME - \$56	57
8.7.8	IFVCO_CAL_WRITE - \$57	57
8.7.9	IFVCO_CAL_COUNT - \$58	57
8.7.10	IFVCO_CAL_TIME - \$59	58
8.7.11	IFVCO_STARTUP_TIME - \$5A	58
8.7.12	VCO_BIAS_CAL_READ - \$5B	58
8.7.13	RFVCO_CAL_READ - \$5C	58
8.7.14	IFVCO_CAL_READ - \$5D	58
8.7.15	VCO_CAL_STAT - \$5E	59
8.8	LO Control	59
8.8.1	LO_CONTROL - \$3F	59
8.8.2	LO_CONTROL_RD - \$CF	60
8.9	Device Status Register	60
8.9.1	DEVICE_STATUS - \$C4	60
8.10	Interrupt Enable Register	62
8.10.1	IRQ_ENABLE - \$C5	62
8.11	Power Status Register	62
8.11.1	POWER_STATUS - \$C6	62
9	Application Notes	63
9.1	Typical Transceiver Configuration	63
9.2	Loop Filter Design	64

9.2.1	RF PLL (Fractional N).....	64
9.3	Phase Noise Performance	65
9.3.1	RF PLL	65
9.3.2	IF PLL Phase Noise	67
9.4	RF PLL Lock Time	69
9.5	RF PLL Spurious	70
9.5.1	Types of Spurious	70
9.5.2	MCLK Sidebands	70
9.5.3	Comparison Frequency Sidebands	70
9.5.4	MCLK Boundaries	70
9.5.5	FComp Boundaries	70
9.5.6	Higher Order Boundaries.....	71
9.6	IF PLL Spurious.....	71
10	Packaging	72
10.1	Ordering Information	72

TablePage

Table 1	Definition of Power Supplies	19
Table 2	Power Supply and Decoupling Component Values	20
Table 3	Tx Mixer Input Impedances and Parallel Equivalent Circuit (Normal mode)	23
Table 4	Tx Mixer Output Differential Impedances and Parallel Equivalent Circuit (Normal mode).....	24
Table 5	Tx Mixer Input Differential Impedances and Parallel Equivalent Circuit (SSB mode).....	24
Table 6	Tx Mixer Output Differential Impedances and Parallel Equivalent Circuit (SSB mode).....	25
Table 7	Tx Normal Mixer Matching Components	26
Table 8	Tx Single Sideband Mixer Matching Components.....	27
Table 9	Rx Mixer Input Impedances and Parallel Equivalent Circuit.....	28
Table 10	Rx Mixer Output Impedances and Parallel Equivalent Circuit.....	29
Table 11	Normal Mixer Mode Components	30
Table 12	Image Reject Mixer Mode Components	30
Table 13	LNA Input Impedances and Parallel Equivalent Circuit	31
Table 14	LNA Output Impedances and Parallel Equivalent Circuit	32
Table 15	LNA Components	33
Table 16	3rd Order Loop Filter Example Values	35
Table 17	External Inductor Values for IF Centre Frequencies.....	38
Table 18	Typical Matching Components for 900MHz (850 to 950 MHz)	40
Table 19	IF VCO Divider Settings.....	41
Table 20	LO Connections	43
Table 21	LOIN Match Components.....	43
Table 22	RF VCO Frequency Limits with LO Output Divider Value	43
Table 23	LOOUT Matching Typical Values	44
Table 24	RF Internal VCO Frequency Limits with LO Output Divider Value	45
Table 25	C-BUS Register Map	46

FigurePage

Figure 1	CMX975 Block Diagram.....	6
Figure 2	C-BUS Timing	17
Figure 3	Pin Configuration	18
Figure 4	Power Supply and AC coupling	20
Figure 5	Tx Mixer Impedance (Normal mode, 0dB gain, differential).....	23
Figure 6	Tx Mixer Output Impedance (Normal mode, 0dB gain, differential)	23
Figure 7	Tx Mixer Impedance (SSB mode, 0dB gain, differential)	24
Figure 8	Tx Mixer Output Impedance (SSB mode, 0dB gain, differential)	25
Figure 9	Tx Normal Mixer Matching Circuit	25
Figure 10	Tx Single Sideband Mixer Matching Components.....	26
Figure 11	Rx Mixer Typical Input Impedance.....	28
Figure 12	Rx Mixer Output Impedance (Differential)	29
Figure 13	Components for Receive Mixer Input and Output.....	30
Figure 14	LNA Input Impedance	31
Figure 15	LNA Output Impedance	32
Figure 16	LNA External Components (1.5GHz to 2.7GHz).....	32

Figure 17 Fractional-N Frequency Synthesiser	33
Figure 18 Example External Components – VCO External Loop Filter	35
Figure 19 IF PLL Architecture	37
Figure 20 Typical Matching Values for 900MHz (850 to 950 MHz).....	40
Figure 21 LOIN Match Components.....	43
Figure 22 LO Drive Block Schematic.....	44
Figure 23 LOOUT Matching Components	44
Figure 24 LO Drive Block Schematic.....	45
Figure 25 Typical Application Configuration	63
Figure 26 Phase noise plot of 3.6GHz RF PLL, $I_{cp}=400\mu A$, $F_{Comp}=38.4MHz$, using internal VCO, 60kHz loop bandwidth, PLL type '1100'	65
Figure 27 Phase noise plot of 3.201GHz RF PLL, $I_{cp}=400\mu A$, $F_{Comp}=38.4MHz$, using internal VCO, 60kHz loop bandwidth, PLL type '1100' also showing output in /2 mode (1600MHz), /4 mode (800MHz) and /8 mode (400MHz).....	66
Figure 28 Phase noise plot of 2.8GHz RF PLL, $I_{cp}=400\mu A$, $F_{Comp}=38.4MHz$, using internal VCO, 60kHz loop bandwidth, PLL type '1100'	66
Figure 29 Phase noise plot of 2.8GHz RF PLL, $I_{cp}=400\mu A$, $F_{Comp}=19.2MHz$, using internal VCO, PLL type '1100'	66
Figure 30 Phase noise plot of 3.2GHz RF PLL, $I_{cp}=400\mu A$, $F_{Comp}=19.2MHz$, using internal VCO, 60kHz loop bandwidth, PLL type '1100' also showing output in /2 mode (1600MHz), /4 mode (800MHz) and /8 mode (400MHz)	67
Figure 31 Phase noise plot of 3.6GHz RF PLL, $I_{cp}=400\mu A$, $F_{Comp}=19.2MHz$, using internal VCO, PLL type '1100'	67
Figure 32 Phase noise plot of 900MHz IF PLL, $I_{cp}=400\mu A$, $F_{Comp}=1.2MHz$, $K_{vco}=10MHz/V$	67
Figure 33 Phase noise plot of 900 MHz IF PLL, $I_{cp}=400\mu A$, $F_{Comp}=1.2MHz$, also showing the effects of selecting the /4 (225 MHz), /8 (112.5MHz) and /16 (56.25 MHz) outputs	68
Figure 34 Lock time for frequency change 2.850GHz to 3.450GHz, $I_{cp}=400\mu A$, $F_{Comp}=19.2MHz$, using internal VCO, 60 kHz loop bandwidth, PLL type '1100', without Fastlock function, $Jump=300\mu s$	69
Figure 35 Lock time for frequency change 2.850GHz to 3.450GHz, $I_{cp}=400\mu A$, $F_{Comp}=19.2MHz$, using internal VCO, 60kHz loop bandwidth, PLL type '1100', with Fastlock function (x12, 100 μs), $Jump=200\mu s$	69
Figure 36 Lock time for frequency change 3.205 to 3.195GHz, $I_{cp}=400\mu A$, $F_{Comp}=19.2MHz$, using internal VCO, 60kHz loop bandwidth, PLL type '1100', without Fastlock function, $Jump=150\mu s$	70
Figure 37 Reference spur plot of 900MHz IF PLL	71
Figure 38 Q4 Mechanical Outline	72

1.1 History

Version	Changes	Date
3	Section 10: Updated Q4 package diagram	December 2019
2	Document updated to Provisional status	March 2018
1	First public release	December 2017

This is Provisional Information; changes and additions may be made to this specification. Parameters marked TBD or left blank will be included in later issues. Items that are highlighted or greyed out should be ignored. These will be clarified in later issues of this document. Information in this datasheet should not be relied upon for final product design.

2 Block Diagram

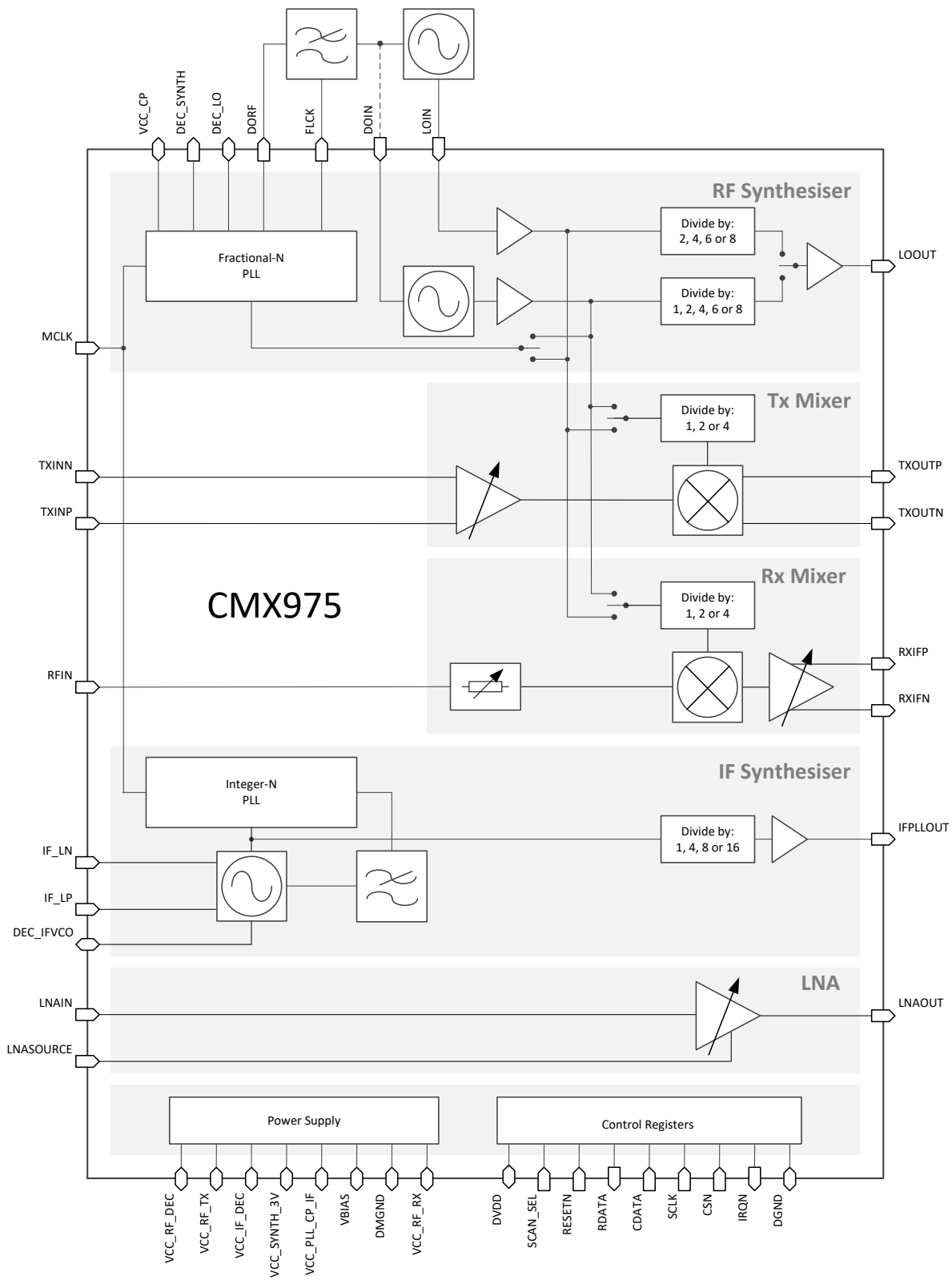

Figure 1 CMX975 Block Diagram

3 Performance Specification

3.1 Electrical Performance

3.1.1 Absolute Maximum Ratings

Exceeding these maximum ratings can result in damage to the device.

	Min.	Max.	Units
Supply ($AV_{DD} - AV_{SS}$) or ($DV_{DD} - DV_{SS}$) or ($CPV_{DD} - AV_{SS}$)	-0.3	+4.0	V
Voltage on any pin to AV_{SS} or DV_{SS}	-0.3	* $V_{max} + 0.3$	V
Voltage between AV_{SS} pins and DV_{SS}	-50	+50	mV
Voltage between AV_{DD} and CPV_{DD}	-0.3	+0.3	V
Current into or out of pins:			
connected to AV_{DD} , AV_{DDTX} , AV_{SS} , DV_{DD} , DV_{SS} or CPV_{DD}	-75	+75	mA
any other pin	-30	+30	mA

* V_{max} The maximum value of the supplies DV_{DD} , AV_{DD} , AV_{DDTX} , CPV_{DD1} and CPV_{DD2}

Q4 Package	Min.	Max.	Units
Total Allowable Power Dissipation at $T_{AMB} = 25^{\circ}C$	–	1820	mW
Derating (see Note below)	–	18.2	mW/ $^{\circ}C$
Storage Temperature	-55	+125	$^{\circ}C$
Operating Temperature	-40	+85	$^{\circ}C$

Note: Junction-to-ambient thermal resistance is dependent on board layout and mounting arrangements. The derating factor stated will be better than this with good connection between the device and a ground plane or heat sink.

3.1.2 Operating Limits

	Notes	Min.	Max.	Units
Analogue Supply ($AV_{DD} - AV_{SS}$)		2.7	3.6	V
Charge Pump Supply ($CPV_{DD} - AV_{SS}$)		2.7	3.6	V
Digital Supply ($DV_{DD} - DV_{SS}$)		1.7	3.6	V
Operating Temperature (see Note above)		-40	+85	$^{\circ}C$

3.1.3 Operating Characteristics

3.1.3.1 DC Parameters

For the following conditions unless otherwise specified:

$AV_{DD} = CPV_{DD} = 2.7V$ to $3.6V$; $DV_{DD} = 1.7V$ to $3.6V$; $AV_{SS} = DV_{SS} = 0V$; and $T_{AMB} = +25^{\circ}C$.

External components and values as shown in section 7.5.2.

DC Parameters	Notes	Min.	Typ.	Max.	Units
Total Current Consumption					
Power save mode	1	–	64	–	μA
V_{BIAS} only	3	–	1	–	mA
Operating Currents					
Tx mixer, normal mode with LO input	7	–	40	–	mA
Tx mixer, image reject mode with LO input	7	–	90	–	mA
Rx mixer normal mode with LO input	7	–	30	–	mA
Rx mixer, image reject mode with LO input	7	–	40	–	mA
Rx LNA		–	9.5	–	mA
RF Synth Only (LO input)		–	20	–	mA
RF Synth + VCO		–	30	–	mA
IF Synth + VCO		–	8	13	mA
RF LO Output (Divide by 1, minimum bias)	5	–	4.5	–	mA
RF LO Output (Divide by 8, maximum bias)	5	–	14	–	mA
IF LO Divider	5a		0.9		mA
Current from DV_{DD}	2	–	630	900	μA
Logic ‘1’ Input Level		70%	–	–	DV_{DD}
Logic ‘0’ Input Level		–	–	30%	DV_{DD}
Output Logic ‘1’ Level ($I_{OH} = 0.6$ mA)		80%	–	–	DV_{DD}
Output Logic ‘0’ Level ($I_{OL} = -1.0$ mA)		–	–	+0.4	V
External Bias Voltage (V_{BIAS})	6	–	1.2	–	V
Power up time					
Voltage Reference	4	–	–	0.5	ms
All blocks except Voltage Reference	4	–	–	10	μs

Notes:

1. Powersave mode includes after a general reset with all analogue and digital supplies applied and also in the case with DV_{DD} applied but with all analogue supplies disconnected (i.e. in this later scenario power from DV_{DD} will not exceed the specified value whatever the state of the registers).
2. Assumes 30pF on each C-BUS interface line and an operating serial clock frequency of 5MHz.
3. The stated current drawn here is with the bandgap reference and accompanying bias current generators enabled only, all other circuitry is disabled.
4. As measured from the rising edge of CSN.
5. Additional current when LO Output (to LOOUT pin) is enabled.
- 5a. Additional current when IF LO output divider is enabled, independent of division ratio.
6. $R1 = 47.5k\Omega$, as shown in Figure 4.
7. LO divide by 2 mode.

3.1.3.2 AC Parameters – Low Noise Amplifier Section

For the following conditions unless otherwise specified:

$AV_{DD} = AV_{DDTX} = 3.3V$; $DV_{DD} = 1.8V$; $AV_{SS} = DV_{SS} = 0V$; $T_{AMB} = +25^{\circ}C$.

External components and values as shown in section 5.

LNA	Notes	Min.	Typ.	Max.	Units
Gain					
1000 MHz		–	19	–	dB
1500 MHz		–	17	–	dB
2700 MHz		–	14	–	dB
Reverse Isolation (S_{12})					
1000 MHz		–	-45	–	dB
1500 MHz		–	-30	–	dB
2700 MHz		–	-26	–	dB
Gain Control Range					
Gain Control Step Size					
		4	6	8	dB
Gain Control Step Error					
		–	–	2	dB
Noise Figure					
1000 MHz	31,32	–	1.75	–	dB
1500 MHz	31,32	–	1.7	–	dB
2700 MHz	31,32	–	2.0	–	dB
Third Order Intercept Point (input)					
1000 MHz	31,32	–	0	–	dBm
1500 MHz	31,32	–	2	–	dBm
2700 MHz	31,32	–	2	–	dBm
Variation in IIP3 with Gain Control					
	33	–	5	–	dB
1 dB Gain Compression Point (input)					
1000 MHz	31,32	–	-10	–	dBm
1500 MHz	31,32	–	-10	–	dBm
2700 MHz	31,32	–	-11	–	dBm
Input Impedance					
	31	–	–	–	Ω
Output Impedance					
	31	–	50	–	Ω
Operating Frequency Range					
		1000	–	2700	MHz
LO Leakage at LNA Input					
		–	–	-90	dBm

Notes:

31. External matching may be used to optimise LNA performance for specific frequencies, see section 5.
32. Maximum gain.
33. Change in measured IIP3 between maximum gain and minimum gain, measured at 1500MHz.

3.1.3.3 AC Parameters – Receive Mixer

For the following conditions unless otherwise specified:
 $AV_{DD} = AV_{DDTX} = 3.3V$; $DV_{DD} = 1.8V$; $AV_{SS} = DV_{SS} = 0V$ $T_{AMB} = +25^{\circ}C$.
 External components and values as shown in section 5.

Rx Mixer	Notes	Min.	Typ.	Max.	Units
RF Frequency Range		1000	–	2700	MHz
LO Frequency Range	43	700	–	3000	MHz
IF Output Range – Image Reject Mode		200	225	250	MHz
IF Output Range – Normal Mode		10	–	300	MHz
Gain (Image Reject Mode)					
RF= 1000 MHz, IF = 225 MHz	40	–	3	–	dB
RF= 1500 MHz, IF = 225 MHz	40	0	3	–	dB
RF = 2700 MHz, IF = 225 MHz	40	–	2	–	dB
Noise Figure (Image Reject Mode)					
RF= 1000 MHz, IF = 225 MHz		–	14	–	dB
RF= 1500 MHz, IF = 225 MHz		–	14	–	dB
RF = 2700 MHz, IF = 225 MHz		–	15	–	dB
Input Third Order Intercept Point (Image Reject Mode)					
RF= 1000 MHz, IF = 225 MHz	45	–	6	–	dBm
RF= 1500 MHz, IF = 225 MHz	45	–	6	–	dBm
RF = 2700 MHz, IF = 225 MHz	45	–	7	–	dBm
Input 1dB Compression Point (Image Reject Mode)					
RF= 1000 MHz, IF = 225 MHz		–	-2	–	dBm
RF= 1500 MHz, IF = 225 MHz		–	-2	–	dBm
RF = 2700 MHz, IF = 225 MHz		–	-2	–	dBm
Gain (Normal Mode)					
RF= 1000 MHz, IF = 150 MHz	40	–	7	–	dB
RF= 1500 MHz, IF = 150 MHz	40	2	6	–	dB
RF = 2700 MHz, IF = 225 MHz	40	–	5	–	dB
Noise Figure (Normal mode)					
RF= 1000 MHz, IF = 150 MHz		–	10	–	dB
RF= 1500 MHz, IF = 150 MHz		–	9	–	dB
RF = 2700 MHz, IF = 225 MHz		–	10	–	dB
Input Third Order Intercept Point (Normal Mode)					
RF= 1000 MHz, IF = 150 MHz	45	–	6	–	dBm
RF= 1500 MHz, IF = 150 MHz	45	–	7	–	dBm
RF = 2700 MHz, IF = 225 MHz	45	–	9	–	dBm

Rx Mixer (cont'd)	Notes	Min.	Typ.	Max.	Units
Input 1dB Compression Point (Normal Mode)					
RF= 1000 MHz, IF = 150 MHz		–	0	–	dBm
RF= 1500 MHz, IF = 150 MHz		–	1	–	dBm
RF = 2700 MHz, IF = 225 MHz		–	4	–	dBm
Image Rejection	42	30	35	–	dB
Gain Control Range		–	18	–	dB
Gain Control Step Size		5	6	7	dB
Gain Control Absolute Error		–	–	2	dB
LO Divider Ratios (selectable)	44	–	1, 2 or 4	–	
LO Leakage at Input		–	-40	–	dBm
Blocking	41	90	95	–	dB

Notes:

40. External matching (as necessary to 50Ω), see section 5
41. Test method based on EN 300 113; including operation of selectable dividers, measurements at ±1MHz, ±5MHz and ±10MHz offsets.
42. RF= 1500MHz, IF = 225MHz, LO = 2550MHz
43. After divider
44. Divide by 2 or 4 must be selected in image reject mode.
45. Input: two-tone signal, -30dBm per tone.

3.1.3.4 AC Parameters – Low Noise Amplifier & Mixer Combined Performance

For the following conditions unless otherwise specified:

$AV_{DD} = AV_{DDTX} = 3.3V$; $DV_{DD} = 1.8V$; $AV_{SS} = DV_{SS} = 0V$; $T_{AMB} = +25^{\circ}C$.

External components and values as shown in section 4.

LNA & Mixer	Notes	Min.	Typ.	Max.	Units
1.5GHz input @ -30dBm to 225MHz output. Mixer set to divide by 2.					
LO = 2.55GHz					
Gain	46	17	20	21	dB
LO = 3.45GHz					
Gain	46	18	20	22	dB
Input Third Order Intercept Point	46		-4		dBm

Notes:

46. External matching optimised for LNA output to Mixer input connection; no additional image filtering used.

3.1.3.5 AC Parameters – Transmit Mixer

For the following conditions unless otherwise specified:
 $AV_{DD} = AV_{DDTX} = 3.3V$; $DV_{DD} = 1.8V$; $AV_{SS} = DV_{SS} = 0V$ $T_{AMB} = +25^{\circ}C$.
 External components and values as shown in section 5.

Tx Mixer	Notes	Min.	Typ.	Max.	Units
RF Frequency Range		1000	–	2700	MHz
LO Frequency Range	53	700	–	3000	MHz
IF Input Range – Normal Mode		30	–	500	MHz
IF Input Range – Sideband suppression Mode		200	225	250	MHz
Gain (Normal Mode)					
RF= 1000 MHz, IF = 150 MHz	50	–	2	–	dB
RF = 2700 MHz, IF = 225 MHz	50	–	2	–	dB
Noise Figure (Normal Mode)					
RF= 1000 MHz, IF = 150 MHz		–	14	–	dB
RF = 2700 MHz, IF = 225 MHz		–	15	–	dB
Output Third Order Intercept Point (Normal Mode)					
RF= 1000 MHz, IF = 150 MHz		–	TBD	–	dBm
RF= 1600 MHz, IF = 225 MHz		–	20	–	dBm
RF = 2700 MHz, IF = 225 MHz		–	21	–	dBm
Output 1dB Compression Point (Normal Mode)					
RF= 1000 MHz, IF = 150 MHz		–	9	–	dBm
RF= 1600 MHz, IF = 225 MHz		–	11	–	dBm
RF = 2700 MHz, IF = 225 MHz		–	11	–	dBm
Gain (Sideband Suppression Mode)					
RF= 1000 MHz, IF = 225 MHz	50	–	5	–	dB
RF = 2700 MHz, IF = 225 MHz	50	–	0	–	dB
Noise Figure (Sideband Suppression Mode)					
RF= 1000 MHz, IF = 225 MHz		–	12	–	dB
RF = 2700 MHz, IF = 225 MHz		–	12	–	dB
Output Third Order Intercept Point (Sideband Suppression Mode)					
RF= 1000 MHz, IF = 225 MHz	56	–	20	–	dBm
RF= 1600 MHz, IF = 225 MHz	56	–	21	–	dBm
RF = 2700 MHz, IF = 225 MHz	56	–	19	–	dBm
Output 1dB Compression Point (Sideband Suppression Mode)					
RF= 1000 MHz, IF = 225 MHz	56	–	10	–	dBm
RF= 1600 MHz, IF = 225 MHz	56	–	11	–	dBm
RF = 2700 MHz, IF = 225 MHz	56	–	9	–	dBm

Tx Mixer (cont'd)	Notes	Min.	Typ.	Max.	Units
Sideband Suppression Rejection	52	30	40	–	dB
Gain Control Range		–	6	–	dB
Gain Control Step Size		2.5	3	3.5	dB
Gain Control Absolute Error		–	–	2	dB
LO Divider Ratios (selectable)	55	–	1, 2 or 4	–	
LO Leakage at Output		–	-50	-30	dBm
Output Noise Floor	51	–	-154	–	dBm/Hz
Output Noise	54	–	-145	–	dBc/Hz

Notes:

- 50. External matching (as necessary to 50Ω), see section 5 not including balun losses
- 51. Measurement at ±7.5MHz offset, no input signal, 0 dB gain setting
- 52. Sideband Suppression Mode (Image reject mode) enable
- 53. After divider
- 54. Measurement at ±7.5MHz offset, Input signal 0 dBm at 150 MHz, RF output =1.5 GHz, 0 dB gain setting.
- 55. Divide by 2 or 4 must be selected in the image reject mode.
- 56. External LO

3.1.3.6 AC Parameters – PLLs

For the following conditions unless otherwise specified:

$AV_{DD} = CPV_{DD} = 3.3V$; $DV_{DD} = 1.8V$; $AV_{SS} = DV_{SS} = 0V$; and $T_{AMB} = +25^{\circ}C$.

External components and values as shown in section 5.

AC Parameters	Notes	Min.	Typ.	Max.	Unit
Clocks					
MCLK frequency (f_{MCLK})		5	–	40	MHz
MCLK sensitivity (AC-coupled)		0.2	–	1.2	Vp-p
MCLK slew rate (AC-coupled)		10	–	–	V/ μ s
MCLK amplifier phase noise		–	-142	–	dBc/Hz
RF Synthesiser					
RF input frequency		700	–	6000	MHz
RF slew rate		300	–	–	V/ μ s
Charge pump sink/source (programmable)		25	–	400	μ A
Charge pump absolute accuracy		-20	–	20	%
Charge pump matching		-4	–	4	%
Charge pump compliance range		0.5	–	$CPV_{DD1} - 0.5$	V
PD comparison frequency (f_{COMP})	10	1.2	–	40	MHz
N-Divider range (Integer mode)		32	–	2047	
N-Divider range (Fractional mode)		32	–	2047	
1Hz normalised phase noise floor	12, 14	–	-209	–	dBc/Hz
	15	-	-212	-	dBc/Hz
IF Synthesiser					
RF frequency		500	–	1000	MHz
PD comparison frequency		100	1000	2500	kHz
Nominal charge pump current		25	–	400	μ A
N-Divider range		25	–	10000	
R-Divider range		2	–	400	
1Hz normalised phase noise floor	11, 12, 13	–	-211	–	dBc/Hz

Notes:

10. During internal RF VCO calibration, the comparison frequency should be ≥ 4.8 MHz.
11. MCLK = 19.2MHz sinewave, 400mVp-p, measured at 1kHz offset.
12. 1Hz Normalised Phase Noise Floor (PN1Hz) can be used to calculate the phase noise within the PLL loop bandwidth by:
Measured Phase Noise (in 1Hz) = $-PN1Hz - 20\log_{10}(N) - 10\log_{10}(f_{comparison})$.
where: $f_{comparison}$ = Frequency at the output of the reference divider; N = main divider ratio.
13. IF PLL locked at 900 MHz; $IFP_{LL_RDIV} = 8$ (2.4 MHz), $IFP_{LL_NDIV} = 375$, $I_{cp} = 200 \mu A$; improves with higher I_{cp} setting.
14. RF PLL / VCO locked at 3.6GHz; $RF_{P_{LL_RDIV}} = 1$ (19.2 MHz), $RF_{P_{LL_IDIV}} = 187$, $I_{cp} = 400 \mu A$; Fractional-N mode.
15. RF PLL / VCO locked at 3.6GHz; $RF_{P_{LL_RDIV}} = 1$ (38.4 MHz), $RF_{P_{LL_IDIV}} = 93$, $I_{cp} = 400 \mu A$; Fractional-N mode.

VCO and LO

For the following conditions unless otherwise specified:

$AV_{DD} = CPV_{DD} = 3.3V$; $DV_{DD} = 1.8V$; $AV_{SS} = DV_{SS} = 0V$; and $T_{AMB} = +25^{\circ}C$. External components and values as shown in Figure 4 and Table 2.

AC Parameters	Notes	Min.	Typ.	Max.	Unit
RF VCO					
Frequency range		2800	–	3600	MHz
K_{VCO}		–	60	–	MHz/V
Phase Noise at 100 kHz offset	20	–	-101	–	dBc/Hz
Phase Noise at 1 MHz offset	20	–	-126	–	dBc/Hz
Phase Noise at 10 MHz offset	20	–	-144	–	dBc/Hz
LO Input					
Input level					
700 to 4000 MHz		-20	-10	0	dBm
4000 to 6000 MHz		-10	-5	0	dBm
Input Impedance		–	TBD	–	Ω
Frequency range		700	–	6000	MHz
RF LO Output					
Frequency Range	21	350	–	3600	MHz
LO Output divide by 2	22	1400		1800	MHz
LO Output divide by 4	22	700		900	MHz
LO Output divide by 6	22	466.67		600	MHz
LO Output divide by 8	22	350		450	MHz
Output Level		–	-7	–	dBm
IF VCO					
Frequency range	23	500	–	1000	MHz
K_{VCO}		–	11	–	MHz/V
Phase Noise at 10kHz offset	24	–	-86	–	dBc/Hz
Phase Noise at 100kHz offset	24	–	-111	–	dBc/Hz
Phase Noise at 1MHz offset	24	-	-135	-	dBc/Hz
IF LO Output					
Frequency Range	21,26	500	–	1000	MHz
LO Output divide by 4	22	125		250	MHz
LO Output divide by 8	22	62.5		125	MHz
LO Output divide by 16	22	31.25		62.5	MHz
Output Level	25	-20	-15	–	dBm

Notes:

20. RF frequency of 1.6GHz (VCO / PLL at 3.2GHz, output divide by 2); loop comparison frequency = 19.2MHz.
21. LO output divide function disabled.
22. LO output divide function enabled.
23. Tuned with external inductor or PCB track. While operation is possible with other inductor values above and below this frequency range, performance is not validated.
24. Operating frequency 500MHz.
25. Unmatched, high current mode
26. The IFVCO frequency is intended to be essentially fixed apart from a small tuning range ± 20 MHz (e.g. to give a small shift between Tx and Rx); the full tuning capability can then be used to compensate for process, voltage and temperature (PVT) variation and for practical choice of inductor.

3.1.3.7 C-BUS Timing Parameters

For the following conditions unless otherwise specified:
 $AV_{DD} = CPV_{DD} = 2.7V$ to $3.6V$; $DV_{DD} = 1.7V$ to $3.6V$; $AV_{SS} = DV_{SS} = 0V$; $T_{AMB} = +25^{\circ}C$.
 External components and values as shown in Figure 4 and Table 2.

C-BUS Timings (See Figure 2)	Notes	Min.	Typ.	Max.	Units
t_{CSE}	CSN-enable to clock-high time	100	–	–	ns
t_{CSH}	Last clock-high to CSN-high time	100	–	–	ns
t_{LOZ}	Clock-low to reply output enable time	0.0	–	–	ns
t_{HIZ}	CSN-high to reply output 3-state time	–	–	1.0	μs
t_{CSOFF}	CSN-high time between transactions	1.0	–	–	μs
t_{NXT}	Inter-byte time	200	–	–	ns
t_{CK}	Clock-cycle time	200	–	100	ns
t_{CH}	Serial clock-high time	100	–	–	ns
t_{CL}	Serial clock-low time	100	–	–	ns
t_{CDS}	Command data set-up time	75.0	–	–	ns
t_{CDH}	Command data hold time	25.0	–	–	ns
t_{RDS}	Reply data set-up time	50.0	–	–	ns
t_{RDH}	Reply data hold time	0.0	–	–	ns

Maximum 30pF load on each C-BUS interface line.

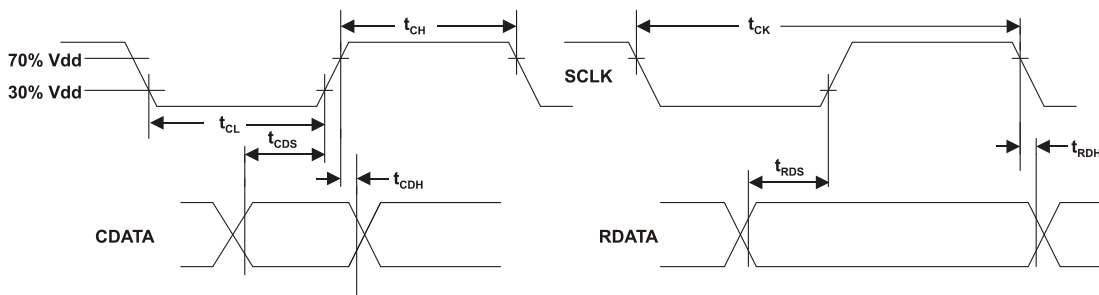
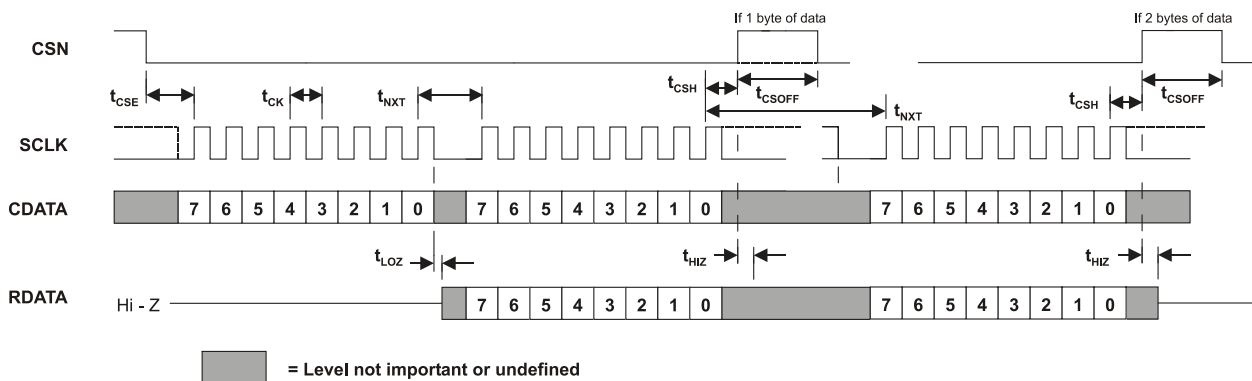

Figure 2 C-BUS Timing

4 Pin and Signal Definitions

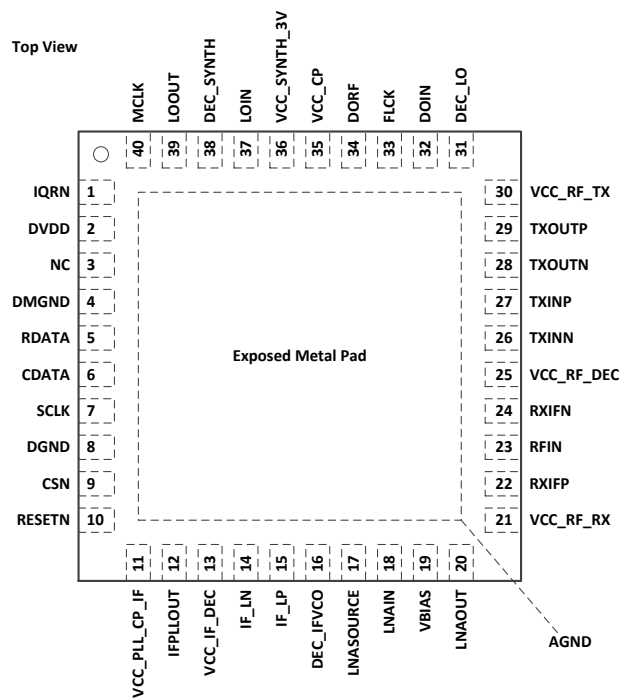

Figure 3 Pin Configuration

4.1 Pin List

Pin No	Pin Name	Type	Pin Function
1	IRQN	OP	C-BUS interrupt request. The output is driven low to DGND when active and is high-impedance when inactive. An external 100kΩ pull-up resistor to DV _{DD} should be connected to this pin.
2	DVDD	PWR	Global digital power supply and decoupling
3	NC	NC	Do not connect to this pin
4	DMGND	PWR	Digital Ground (moat connection)
5	RDATA	TS	A tri-state C-BUS data output. This output is high impedance when not sending data to the host μC. Care should be taken to ensure any inputs to which this pin is connected are not left floating when RDATA is in a high impedance state.
6	CDATA	IP	C-BUS data input
7	SCLK	IP	C-BUS clock
8	DGND	PWR	Digital Ground
9	CSN	IP	C-BUS chip select
10	RESETN	IP	Active low reset pin with internal 75kΩ pull-up resistor
11	VCC_PLL_CP_IF	PWR	IF PLL Charge Pump power supply and decoupling; connect to CPV _{DD2} and decouple when PLL not used.
12	IFPLLOUT	OP	Single ended IF PLL output
13	VCC_IF_DEC	PWR	Decoupling for IF PLL (retain decoupling when IF PLL not used)
14	IF_LN	IP	IF VCO tank negative
15	IF_LP	IP	IF VCO tank positive
16	DEC_IFVCO	PWR	IF VCO Decoupling decouple when PLL not used.
17	LNASOURCE	IP	LNA source connection
18	LNAIN	IP	LNA RF input
19	VBIAS	BIAS	47.5kΩ External bias resistor and decoupling to AV _{SS} . This pin should not be used as a voltage reference.

Pin No	Pin Name	Type	Pin Function
20	LNAOUT	OP	LNA output (DC connection required to AV _{DD}).
21	VCC_RF_RX	PWR	Rx analogue power supply and decoupling AV _{DD} ; decouple when Rx not used.
22	RXIFP	OP	Rx mixer IF output positive (DC connection required to AV _{DD}).
23	RFIN	IP	Rx mixer input (DC connection required to AV _{SS}).
24	RXIFN	OP	Rx mixer IF output negative (DC connection required to AV _{DD}).
25	VCC_RF_DEC	PWR	1.2V analogue supply decoupling (Tx and Rx). Decouple when Tx & Rx not used.
26	TXINN	IP	Tx mixer IF negative input
27	TXINP	IP	Tx mixer IF positive input
28	TXOUTN	IP	Tx mixer output negative (DC connection required to AV _{DDTX})
29	TXOUTP	IP	Tx mixer output positive (DC connection required to AV _{DDTX})
30	VCC_RF_TX	PWR	Tx analogue power supply and decoupling
31	DEC_LO	PWR	Decoupling for VCO supply and RF PLL loop filter reference point (1.2V)
32	DOIN	IP	VCO tuning node (0V to CPV _{DD})
33	FLCK	OP	RF PLL fast lock output
34	DORF	OP	Charge pump output
35	VCC_CP	PWR	Power supply and decoupling for RF PLL charge pump; connect to CPV _{DD1} and decouple even if not used.
36	VCC_SYNTH_3V	PWR	Analogue power supply and decoupling (RF PLL, bias and MCLK buffer); connect to AV _{DD} and decouple when PLL not used.
37	LOIN	IP	External VCO drive in
38	DEC_SYNTH	OP	1.2V regulator decoupling (RF PLL)
39	LOOUT	OP	RF VCO/PLL output
40	MCLK	IP	Master Clock input used for RF and IF PLLs.
EXPOSED METAL PAD	AGND	PWR	The exposed metal pad must be electrically connected to analogue ground.

Notes:

Total = 41 Pins (40 pins and central, exposed metal ground pad)

Unused pins may be left not connected unless otherwise specified.

PWR = Power connection

TS = 3-state output

IP = Input

NC = Do not connect to this pin

OP = Output

4.2 Signal Definitions

Signal Name	Pins	Usage
V _{max}		The maximum value of the supplies DV _{DD} , AV _{DD} , AV _{DDTX} , CPV _{DD1} , and CPV _{DD2}
AV _{DD}	VCC_SYNTH_3V VCC_RF_RX	Power supply for analogue circuits
AV _{DDTX}	VCC_RF_TX	Power supply for analogue Tx circuits
CPV _{DD1}	VCC_CP	Power supply for RF PLL charge pump
CPV _{DD2}	VCC_PLL_CP_IF	Power supply for IF PLL charge pump
CPV _{DD}	VCC_CP, VCC_PLL_CP_IF	CPV _{DD1} and CPV _{DD2}
DV _{DD}	DVDD	Power supply for digital circuits and C-BUS interface
DV _{SS}	DGND, DMGND	Ground for digital circuits
AV _{SS}	AGND	Ground for analogue circuits

Table 1 Definition of Power Supplies

5 Power Supply and Decoupling

This device has separate supply pins for the analogue and digital circuitry; a 3.0V nominal supply is recommended for AV_{DD}, DV_{DD}, CPV_{DD1} and CPV_{DD2}. The digital interface can run at a lower voltage than the rest of the device by setting the DV_{DD} supply to the required interface voltage (see section 3.1.2).

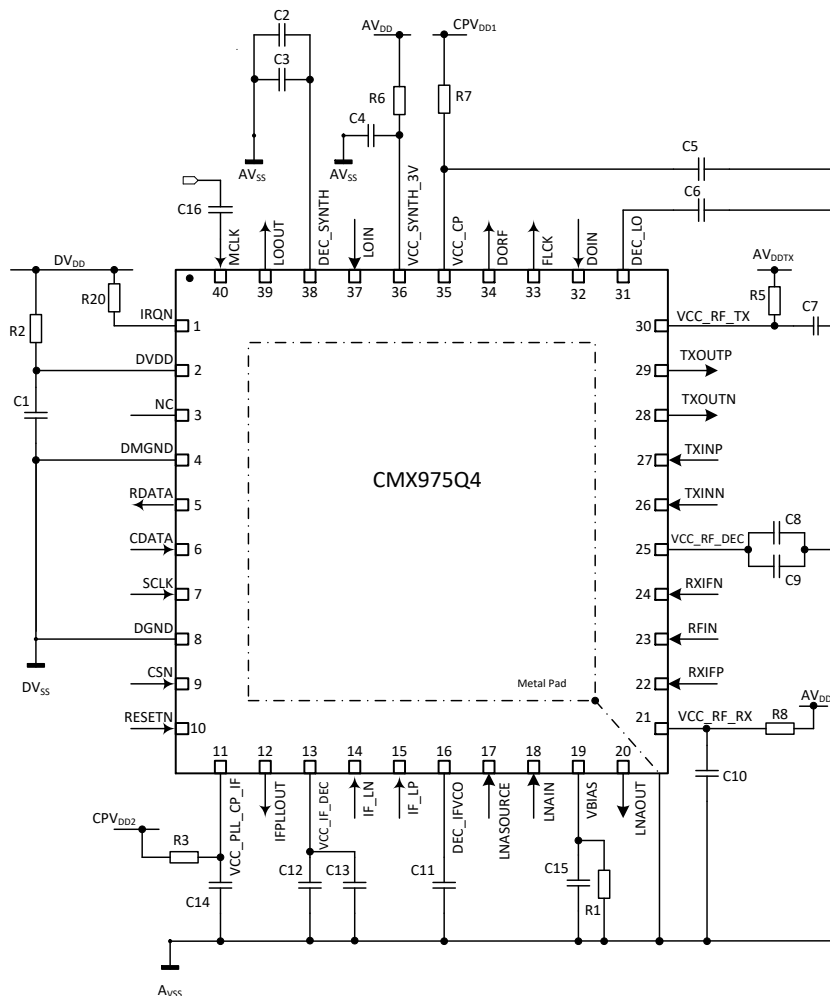

Figure 4 Power Supply and AC coupling

C1	10nF		C9	NF
C2	100nF		C10	10nF
C3	100pF		C11	56nF
C4	10nF		C12	100nF
C5	10nF		C13	100pF
C6	150nF		C14	10nF
C7	10nF		C15	10nF
C8	100nF		C16	10nF
R1	47.5kΩ		R6	3.3Ω
R2	10Ω		R7	3.3Ω
R3	3.3Ω		R8	3.3Ω
R5	3.3Ω		R20	100kΩ

Table 2 Power Supply and Decoupling Component Values

Notes:

1. Maximum Tolerances: Capacitors ±5% Resistors ±1%
2. It is expected that any low-frequency interference on the power supplies will be removed by active regulation; a large capacitor is an alternative but may require more board space and so may not be preferred. It is particularly important to ensure that there is no

- interference from the DV_{DD} to sensitive analogue supplies (AV_{DD}). It is therefore advisable to use separate power supplies for digital and analogue circuits.
3. The supply decoupling shown is intended for RF noise suppression. It is necessary to have a small series impedance prior to the decoupling capacitor for the decoupling to work well. This may be achieved cost effectively by using the resistor and capacitor values shown. The use of resistors results in small dc voltage drops (up to approx 0.1V). Choosing resistor values approximately inversely proportional to the dc current requirements of each supply ensures the dc voltage drop on each supply is reasonably matched. In any case, the resultant dc voltage change is well within the design tolerance of the device. If higher impedance resistors are used (not recommended) then greater care will be needed to ensure the supply voltages are maintained within tolerance, even when parts of the device are enabled or disabled.
 4. It is advisable to have separate ground planes for analogue and digital circuits.

6 Layout Recommendations

The RF performance of the CMX975 is dependant on the PCB design and layout. Grounding arrangements are particularly important to achieving the specified performance. Recommendations are contained in the following guidance:

The evaluation kit has, in general, RF components, connectors and configuration links placed on the top layer, with voltage regulators, supplies and decoupling for the device on the bottom layer. The layout has been optimised for low ground impedance, the shortest possible RF tracking to the pins, and minimal stray capacitance for operation at high frequencies.

To provide all the connections to a small QFN package in a compact layout, along with its associated components and isolation between certain signals, a multi-layer PCB layout is necessary.

A recommended layout may be taken from the evaluation kit (EV9750 / PCB593C), Gerber data for which can be downloaded from the CML website (www.cmlmicro.com).

The LNA is capable of high gain and a low noise figure. As such, care is needed in the layout, decoupling and management of parasitics for optimum performance and stability at all frequencies. This specific LNA output layout requires decoupling to the adjacent VBIAS pin and an additional 100Ω resistor across the two LNA output tracks to ensure unconditional stability at frequencies above 4GHz. This resistor should not be required if a single track to the LNA output pin is used.

For the Tx and Rx mixers, the RF matching circuits have been placed on the top layer and the IF matching circuits on the bottom layer so that the ground plane in between provides built-in isolation between the circuits.

While values are given for suitable RF matching circuits, the optimum component values required for the operating frequencies shown may change if the recommended layout is not followed (particularly for low-value inductors and capacitors).

A good quality dielectric should be used for low loss and consistent high frequency performance. The EV9750 uses Rogers RO4003C ceramic substrate for the upper layer, with the other layers using FR4 / VT481 2116 dielectric.

The central ground pad should provide a good low impedance to ground plane layers, whilst also allowing for reliable solder reflow. A grid of 5 x 5 plated through vias (0.3mm diameter) is recommended.

7 Detailed Description

7.1 Power Management

In total there are four on-chip regulators each with the basic architecture of an error amplifier, with an output pass transistor. Three of the regulators utilise an external capacitor of typically 220nF, these regulators will supply 1.2V to the RF PLL, IF PLL and RF domains respectively. The fourth regulator is used to provide 1.2V for the digital sections of the chip, namely, C-BUS control registers, power control and delta-sigma logic. This regulator is internally stabilised and does not require an external capacitor.

There are two on-chip bandgap reference circuits, one of which provides the 1.2V reference for the three analogue 1.2V supply regulators, while the other provides the 1.2V reference for the digital 1.2V supply regulator.

The on-chip Power On Reset (POR) is used to monitor the digital and analogue supply rails and generate a power down signal in the case of loss of any supply rail. Whenever power is applied to the DVDD pin, the POR circuit ensures that the device powers up into the same state as follows a General Reset command. The RESETN pin on the device will also reset the device to the same state.

7.2 Clock Generator

The MCLK amplifier must be enabled when a digital reference clock is required and is enabled automatically when either the RF or IF PLLs are enabled.

The MCLK amplifier receives the output of an external oscillator, which may be a low amplitude sine wave, and turns it into a 1.2V full range digital signal for use by the RF and IF PLL reference clock dividers and as a reference clock for the digital block. As the input to the amplifier is ac coupled and the amplifier may be enabled or disabled dependent on system configuration, the digital output clock may be unstable for a period of time.

A clock generator circuit will “hold off” the clock to the digital block until it is stable and then start the clock with a full and complete cycle. The status of the MCLK is reported in the status register (\$C4, b7), see section 8.9.

7.3 Tx (Up-conversion) Mixer

The Tx mixer is an up-converting RF mixer with differential input and output. The mixer may be used single-ended, but that will involve a trade-off with ultimate performance. The Tx mixer has a selectable ‘image reject’ (‘single sideband’) mode or may be used in ‘normal’ mode with reduced current.

If the image reject functionality is enabled the mixer must be used in LO/2 or LO/4 mode (NB: with LO/1 image reject mode is not available). In image reject mode the choice of IF is restricted. High-side or low-side operating modes can be selected by C-BUS command.

The registers associated with initialisation of the Tx Mixer are:

- GCR - \$31
- GCR_RD - \$C1

The registers used to configure the Tx Mixer are:

- TX_CON - \$33
- TX_CON_RD - \$C3
- LO_CONTROL - \$3F
- LO_CONTROL_RD - \$CF

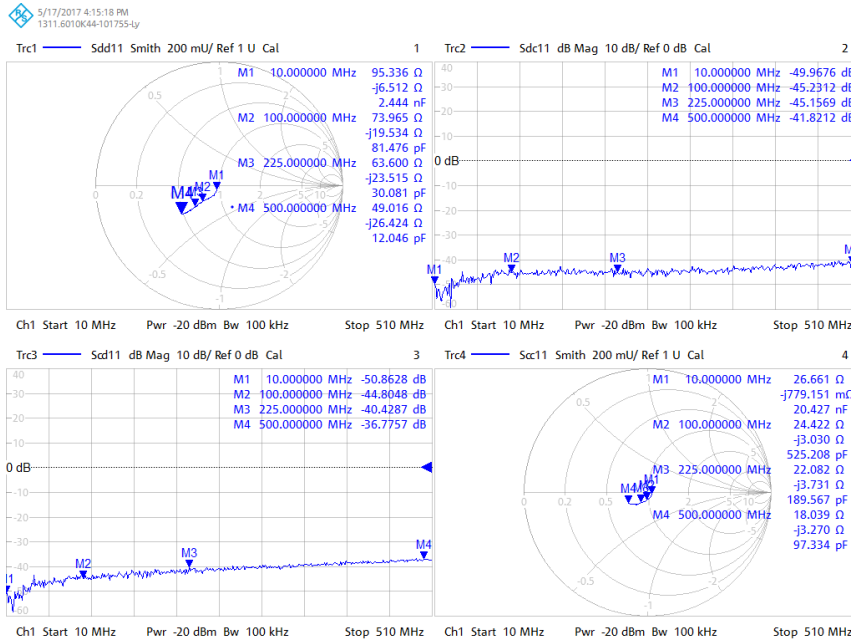

Figure 5 Tx Mixer Impedance (Normal mode, 0dB gain, differential)

Frequency (MHz)	Impedance (Ω -j Ω)	Parallel Equivalent Circuit (R // pF)
10	95.34 -j 6.512	95.8 // 11.4
100	73.97 -j 19.53	79 // 5.25
225	63.6 -j 23.52	72.3 // 3.6
500	49.02 -j 26.42	63.4 // 2.72

Table 3 Tx Mixer Input Impedances and Parallel Equivalent Circuit (Normal mode)

Note that selecting either divide by 1, 2 or 4 for the LO mixer mode will make little difference to the impedance.

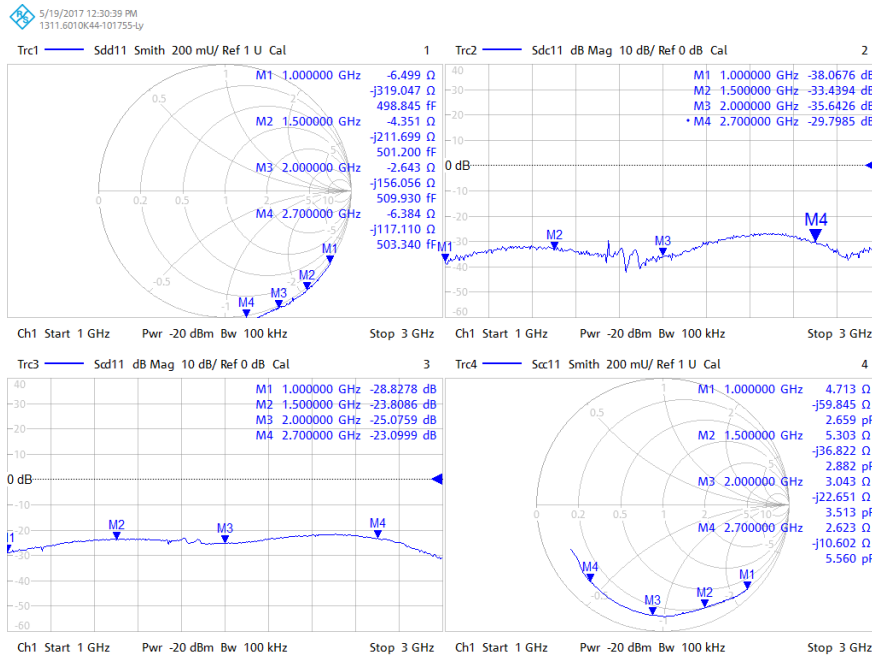

Figure 6 Tx Mixer Output Impedance (Normal mode, 0dB gain, differential)

Frequency (MHz)	Differential Impedance (Ω -/+j Ω)	Parallel Equivalent Circuit (R // pF)
1000	4.71 -j 59.85	764.8 // 2.64
1500	5.3 -j36.8	259 // 2.82
2000	3.04 -j 22.65	171 // 3.45
2700	2.6 -j 10.6	45.6 // 5.24

Table 4 Tx Mixer Output Differential Impedances and Parallel Equivalent Circuit (Normal mode)

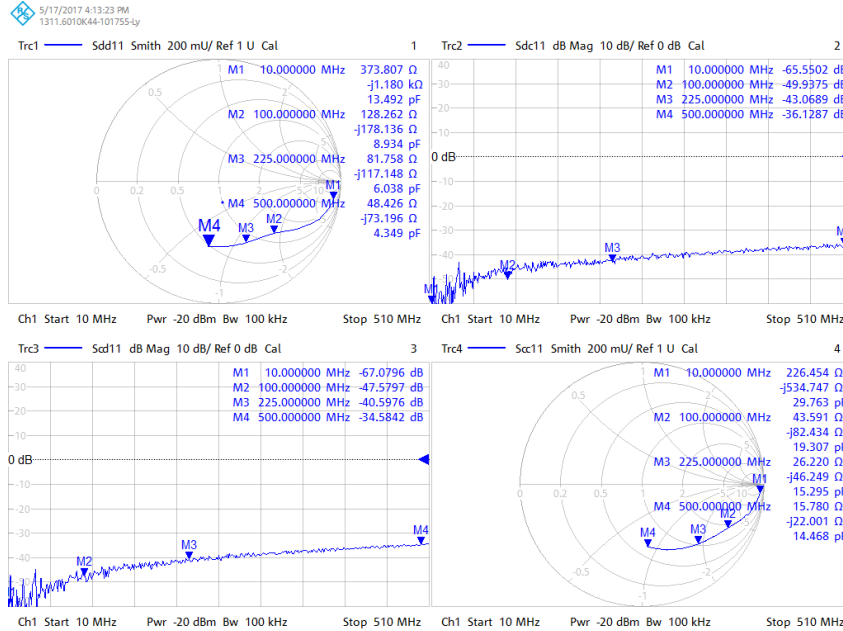

Figure 7 Tx Mixer Impedance (SSB mode, 0dB gain, differential)

Note that selecting divide by 2 or 4 for the LO mixer mode will make little difference to the impedance. Image reject mode is only valid for operation around 225MHz due to the internal networks used to provide phase quadrature, Operation at other IF frequencies will give degraded image rejection.

Frequency (MHz)	Impedance (Ω -/+j Ω)	Parallel Equivalent Circuit (R // pF)
225	82 -j 117	247 // 4

Table 5 Tx Mixer Input Differential Impedances and Parallel Equivalent Circuit (SSB mode)

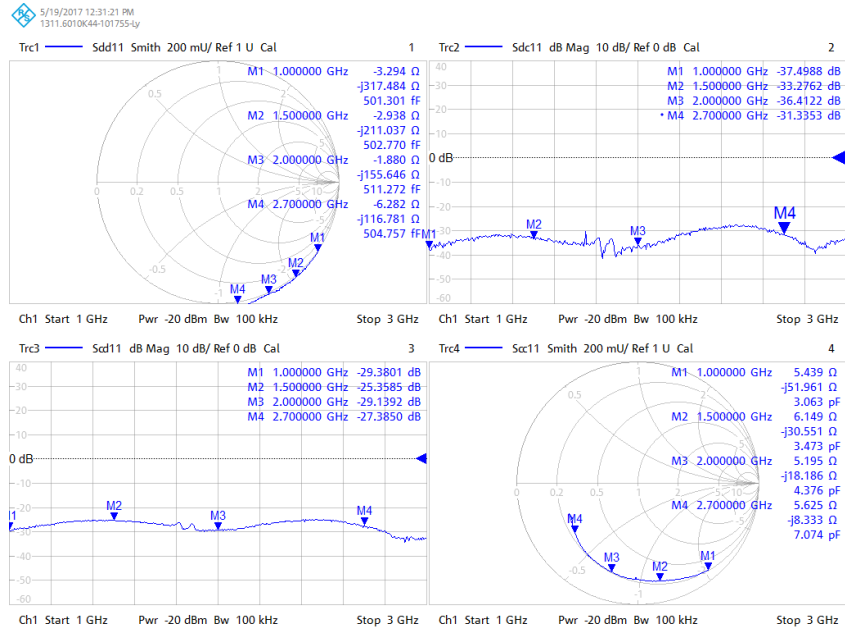

Figure 8 Tx Mixer Output Impedance (SSB mode, 0dB gain, differential)

Frequency (MHz)	Differential Impedance (Ω/-+jΩ)	Parallel Equivalent Circuit (R // pF)
1000	5.44 -j 51.96	503 // 3.03
1500	6.15 -j 30.55	158 // 3.34
2000	5.2 -j 18.19	68 // 4.05
2700	5.625 -j 8.33	17.92 // 4.8

Table 6 Tx Mixer Output Differential Impedances and Parallel Equivalent Circuit (SSB mode)

7.3.1 Matching Circuits

7.3.1.1 Normal Mixer Mode

Typical matching circuits for the Tx Mixer in normal mode are shown in Figure 9 and Table 7. A LC circuit is shown for the IF input match, alternatively a balun may be used. The mixer may be used single-ended but this will result in degraded performance.

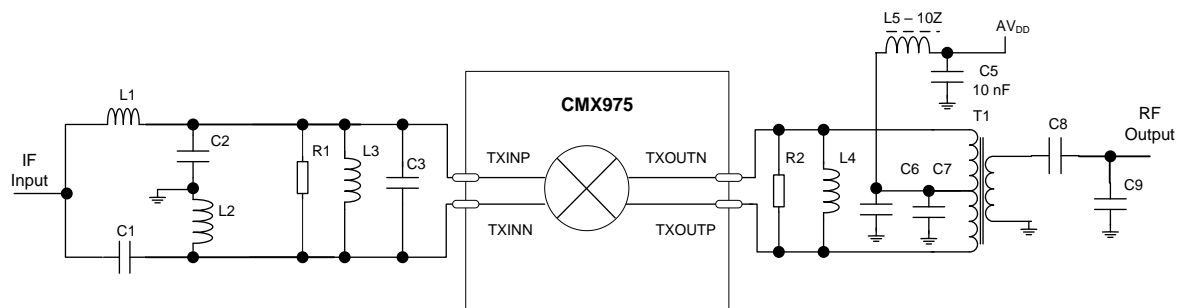

Figure 9 Tx Normal Mixer Matching Circuit

Reference	225MHz (IF)	150MHz(IF)	1GHz(RF)	1.6GHz(RF)	2.7GHz(RF)
C1, C2	12pF	22pF GRM1555	-	-	-
C3	5.6pF	18pF	-	-	-
C6			47pF	22pF	6.8pF
C7			1nF	1nF	1nF
C8			10 nH	0Ω	0 Ω
C9			NF	NF	NF
L1, L2	36nH 0402CS	51nH 0402CS			
L3	56nH 0402CS	56nH 0402CS			
L4	-	-	47nH 0402CS	15nH 0402CS	3.3nH 0402HP
L5	-	-	10 Ω Ferrite	10 Ω Ferrite	10 Ω Ferrite
R1	NF	560 Ω			
R2	-	-	470 Ω	430 Ω	82 Ω
T1	-	-	4:1 Johanson Technology 1720BL15B0200 200 Ω	4:1 Johanson Technology 1720BL15B0200 200 Ω	2:1 Johanson Technology 1720BL15A0100 100 Ω

Notes:

NF: component is not fitted
 Typical capacitors from Murata GRM1555 series
 Example inductor part numbers are from Coilcraft

Note: The IF input matches are designed as simple discrete baluns (L1, L2, C1, and C2) with a 1:1 impedance ratio, i.e. 50 Ω to 50 Ω. In this mode, the mixer input pins present a differential impedance of around 50 Ω // 2.9 pF. L3, R1 and C3 in parallel are then adjusted to resonate with this capacitance and layout parasitics.

Table 7 Tx Normal Mixer Matching Components

7.3.1.2 Single Sideband Tx Mixer Mode

Typical matching circuits for the Tx Mixer in single sideband mode are shown Figure 10 and Table 8. A LC circuit is shown for the IF input match, alternatively a balun may be used.

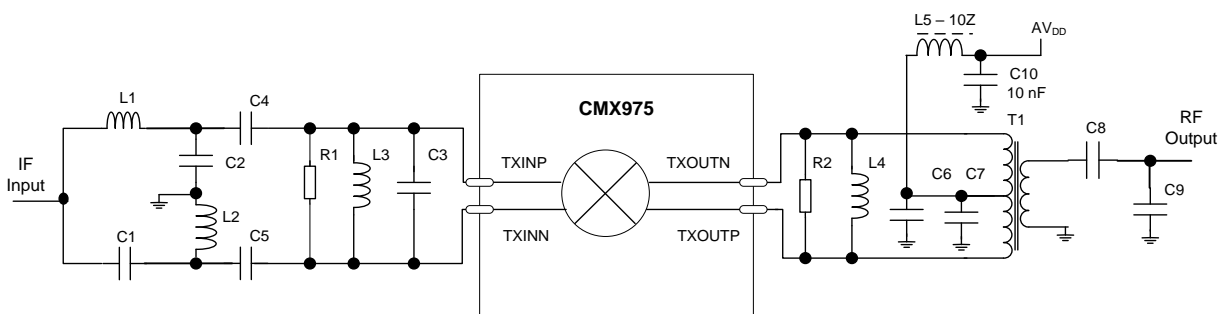

Figure 10 Tx Single Sideband Mixer Matching Components

In the normal mixer mode (i.e. non SSB) there are coupling capacitors on chip hence external coupling capacitors are not needed in normal mixer mode (Figure 9).

In SSB mixer mode the internals of the chip are reconfigured electronically such that external coupling capacitors (C3, C4) are needed (Figure 10).

Reference	225 MHz (IF)	1GHz(RF)	1.6GHz(RF)	2.7GHz(RF)
C1, C2	6.8pF	-	-	-
C4, C5	1nF	-	-	-
C3	3.9pF	-	-	-
C6	-	47pF	22pF	6.8pF
C7	-	1nF	1nF	1nF
C8	-	10 nH	0Ω	0Ω
C9	-	NF	NF	NF
C10	-	10nF	10nF	10nF
L1, L2	68nH 0402CS	-	-	-
L3	56nH 0402CS	-	-	-
L4	-	47nH 0402CS	15nH 0402CS	3.3nH 0402HP
L5	-	10 Ω Ferrite	10 Ω Ferrite	10 Ω Ferrite
R1	NF	-	-	-
R2	-	470 Ω	430 Ω	82 Ω
T1	-	4:1 Johanson Technology 1720BL15B0200 200 Ω	4:1 Johanson Technology 1720BL15B0200 200 Ω	2:1 Johanson Technology 1720BL15A0100 100 Ω

NF: component is not fitted
 Typical capacitors from Murata GRM1555 series
 Example inductor part numbers are from Coilcraft

Table 8 Tx Single Sideband Mixer Matching Components

Note: The IF input matches are designed as simple discrete baluns (L1, L2, C1, and C2) with a 50 Ω to 200 Ω impedance ratio at 225MHz. In this mode, the mixer input pins present a differential impedance of around 200 Ω // 4.2 pF. L3, R1 and C3 in parallel are then adjusted to resonate with this capacitance and layout parasitics.

7.4 Rx (Down-conversion) Mixer

The Rx mixer is a down-converting RF mixer with a single-ended input and a differential output; the output may be used single-ended, but that will involve a trade-off with ultimate performance. The Rx mixer has a selectable 'image reject' ('single sideband') mode or may be used in 'normal' mode with reduced current.

If the image reject functionality is enabled, the mixer must be used in LO/2 or LO/4 mode. In image reject mode, the choice of IF is restricted.

The registers associated with initialisation of the Rx Mixer are:

- GCR - \$31
- GCR_RD - \$C1

The registers used to configure the Rx Mixer are:

- RX_CON - \$32
- RX_CON_RD - \$C2
- LO_CONTROL - \$3F
- LO_CONTROL_RD - \$CF

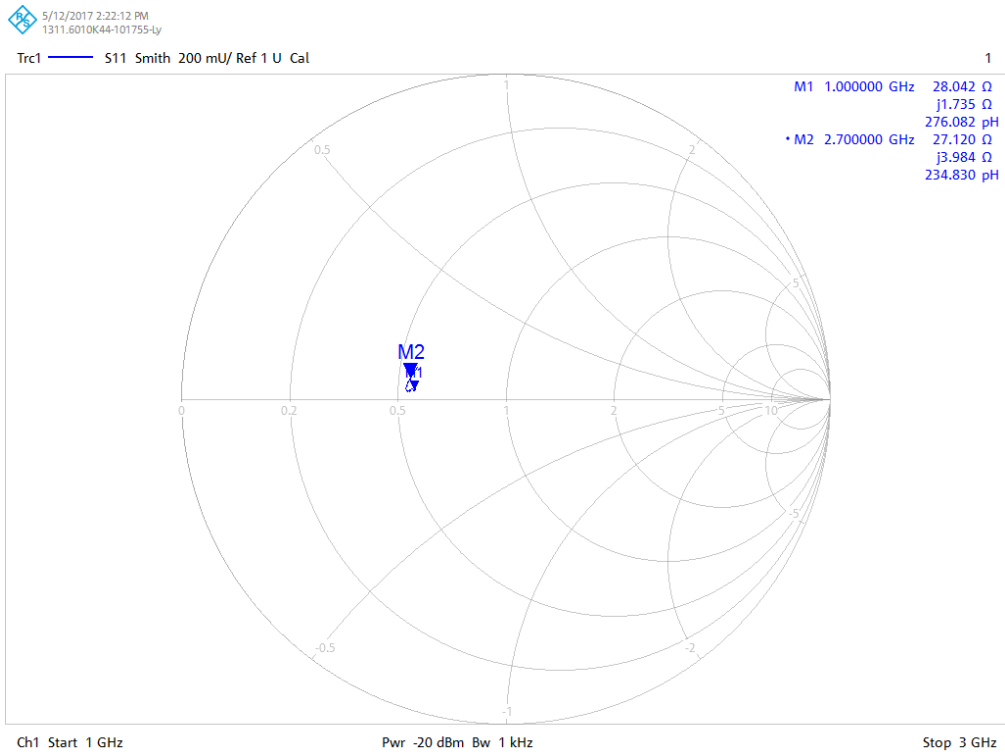

Figure 11 Rx Mixer Typical Input Impedance

The input impedance is consistent across 1 to 3 GHz at around 27 Ω + 0.26 nH and is unaffected by operating mode.

Frequency (MHz)	Impedance (Ω-/+jΩ)	Parallel Equivalent Circuit (R // pF)
1000	28.04 +j 1.735	28.15 // 72.4
2000	27.58 +j 2.856	27.9 // 20.78
2700	27.12 +j 3.984	27.8 // 9.0

Table 9 Rx Mixer Input Impedances and Parallel Equivalent Circuit

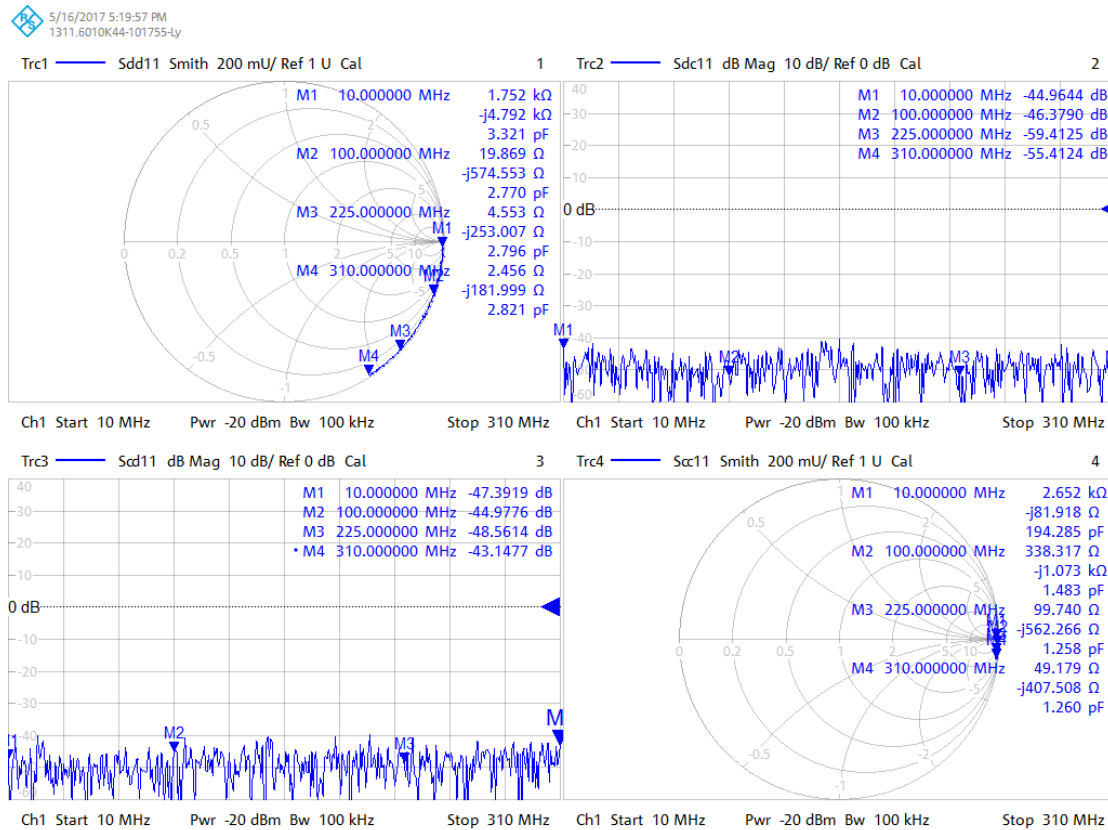

Figure 12 Rx Mixer Output Impedance (Differential)

The mixer output is essentially open drain outputs (very high impedance) with an internal 2.5 pF capacitance across the pins. Note that the output impedance shown in Figure 12 changes little with operating mode (i.e. image reject or normal mode, IF frequency select or gain step).

Frequency (MHz)	Impedance (Ω-/+jΩ)	Parallel Equivalent Circuit (R // pF)
10	2.46 k -j 5.14k	13.2 k // 2.52
50	78.09 -j 1.158k	17.0 k // 2.73
100	19.65 -j 572.4	16.7 k // 2.79
150	7.691 -j 378.3	18.6 k // 2.81
200	4.386 -j 285.5	18.4 k // 2.79
225	5.351 -j 251.9	24.8 k // 2.81
250	3.496 -j 226.4	14.6 k // 2.82
275	2.496 -j 205	16.8 k // 2.82
300	1.954 -j 187.9	17.2 k // 2.9

Table 10 Rx Mixer Output Impedances and Parallel Equivalent Circuit

7.4.1 Matching Circuits

The recommended matching circuit for the receive mixer is shown in Figure 13, component values are shown in the tables in the following sub-sections. Note that a connection to dc ground (AV_{SS}) is required on pin RFIN.

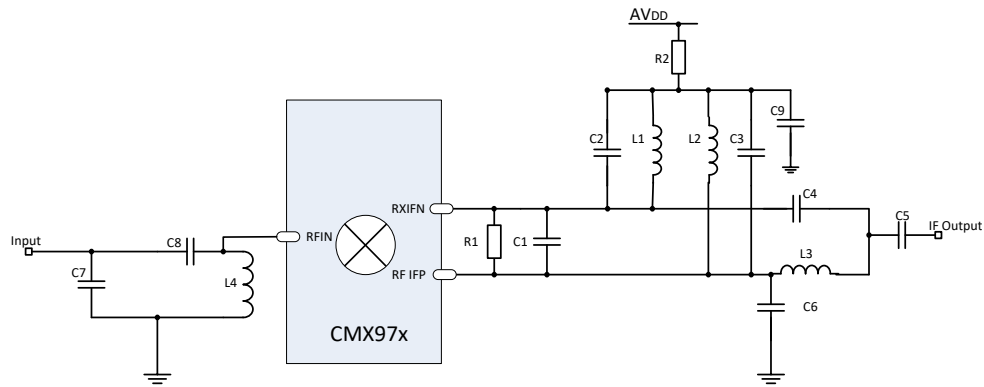

Figure 13 Components for Receive Mixer Input and Output

7.4.1.1 Normal Mixer Mode

Component values for normal mode are given in Table 11 based on the configuration shown in Figure 13.

Reference	RF 1GHz, IF=150MHz IF	RF 1.5GHz, IF=150MHz IF	RF 2.7GHz, IF=225MHz IF
C1	0.8pF	0.8pF	1.0pF
C2	10pF	10pF	1.8pF
C3	10pF	10pF	1.8pF
C4	3.9pF	3.9pF	3.3pF
C5	1nF	1nF	1nF
C6	3.9pF	3.9pF	3.3pF
C7	3.6pF	1.8pF	1.0pF
C8	OR (SHORTED)	OR (SHORTED)	3.6pF
C9	1nF	1nF	1nF
L1	47nH (0402CS)	47nH (0402CS)	33nH (0402CS)
L2	56nH (0402CS)	56nH (0402CS)	39nH (0402CS)
L3	270nH (0603CS)	270nH (0603CS)	180nH (0402HP)
L4	12nH (0402CS)	8.2nH (0402HP)	4.3nH (0402HP)
R1	5.6k Ω	5.6k Ω	5.6k Ω
R2	3.3 Ω	3.3 Ω	3.3 Ω

Note: The quoted values assume 0.5nH for PCB parasitic inductance from pin RFIN to the top of L4 and 1nH from top of L4 to C8.

Table 11 Normal Mixer Mode Components

7.4.1.2 Image Reject Mixer Mode

Component values for the image reject mixer mode are given in Table 12.

Reference	RF 1GHz, IF=112.5MHz IF	RF 1.5GHz, IF=225MHz IF	RF 2.7GHz, IF=225MHz IF
C1	2.2pF	1.0pF	1.0pF
C2	12pF	1.8pF	1.8pF
C3	12pF	1.8pF	1.8pF
C4	5.6pF	3.3pF	3.3pF
C5	1nF	1nF	1nF
C6	5.6pF	3.3pF	3.3pF
C7	3.6pF	1.8pF	1.0pF
C8	OR (SHORTED)	OR (SHORTED)	3.6pF
C9	1nF	1nF	1nF
L1	68nH (0402CS)	33nH (0402CS)	33nH (0402CS)
L2	82nH (0402CS)	39nH (0402CS)	39nH (0402CS)
L3	330nH (0603CS)	180H (0402HP)	180nH (0402HP)
L4	12nH (0402CS)	8.2nH (0402HP)	4.3nH (0402HP)
R1	5.6k Ω	5.6k Ω	5.6k Ω
R2	3.3 Ω	3.3 Ω	3.3 Ω

Note 0.5nH has been assumed for PCB parasitic inductance from RFIN pin to top of L4 and 1nH from top of L4 to C8.

Table 12 Image Reject Mixer Mode Components

The Rx mixer outputs require inductors to AV_{DD} to provide DC current feed. For 225MHz operation, 39nH is used for these. On one side there is a 39nH inductor in parallel with the 180nH of the LC balun – The parallel equivalent of this is 33nH to save one component.

The total capacitance across the output is then chosen to be parallel resonant with the inductance at 225MHz. Capacitors up to AV_{DD} from each output are to reduce common mode signals (particularly 2 x LO) as well as a capacitor across the outputs (taking into account the approximate 2.5pF internal capacitance across the outputs).

The real component of the chip output is then defined mainly by the inductor Q (as the chip itself is high) so the resistor across the output should be chosen to make the total real component about 1200Ω.

The LC balun transforms this balanced output at around 1200Ω to 50Ω unbalanced.

7.5 Low Noise Amplifier (LNA)

The LNA offers three steps of gain reduction, each step being 6dB. The input and output matching are performed with the use of external components (see section 7.5.2).

7.5.1 LNA S-parameters

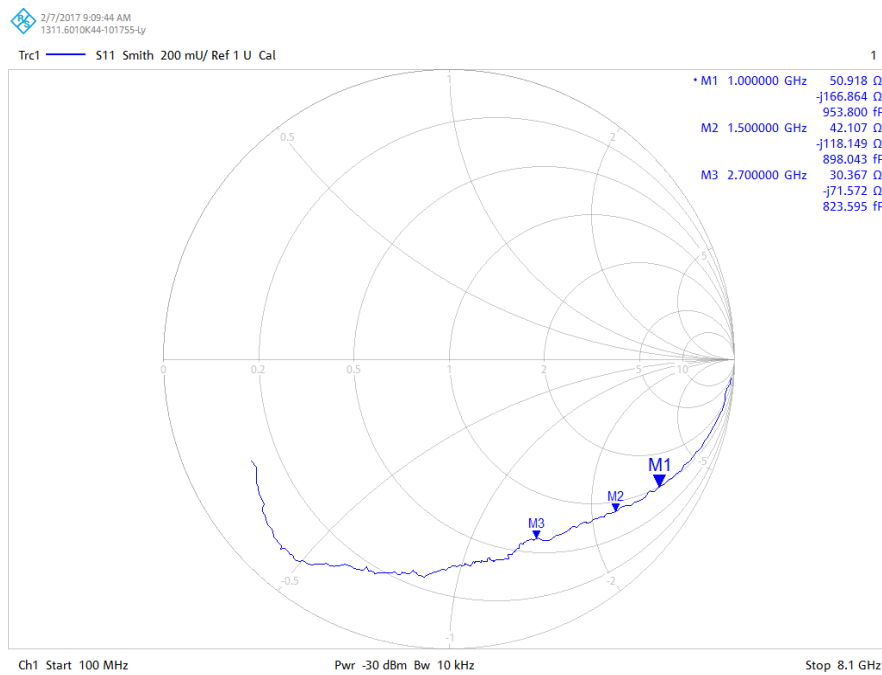

Figure 14 LNA Input Impedance

Frequency (MHz)	Impedance (Ω-/+jΩ)	Parallel Equivalent Circuit (R // pF)
1000	50.92 -j 166.9	101.6 // 1.56
1500	42.11 -j 118.1	374.1 // 0.8
2700	30.37 -j 71.57	198 // 0.7

Table 13 LNA Input Impedances and Parallel Equivalent Circuit

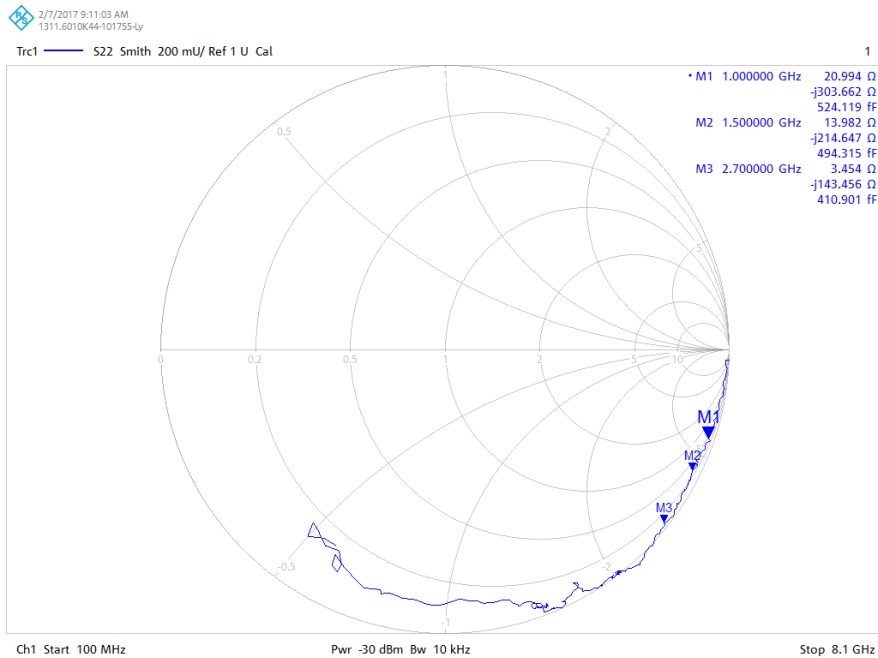

Figure 15 LNA Output Impedance

Frequency (MHz)	Impedance (Ω-/+jΩ)	Parallel Equivalent Circuit (R // pF)
1000	21 -j 303.6	4.4k // 0.52
1500	14 -j 214.7	3.32k // 0.49
2700	3.45 -j 143.5	5.86k // 0.41

Table 14 LNA Output Impedances and Parallel Equivalent Circuit

7.5.2 Matching Circuits

Typical matching circuits for the LNA are shown in Figure 16 and Table 15. The CMX975 LNA is capable of high gain and low noise figure. As such, care is needed in the layout, decoupling and management of parasitics for optimum performance and stability. An additional decoupling capacitor from the C5/C6/C7 node to the adjacent VBIAS pin may be required. Please refer to the appropriate section in the User Manual for the EV9750 evaluation board and its supporting documentation for examples using this specific layout.

Unmatched S-Parameter files are available for the LNA. These are available from the CML web site.

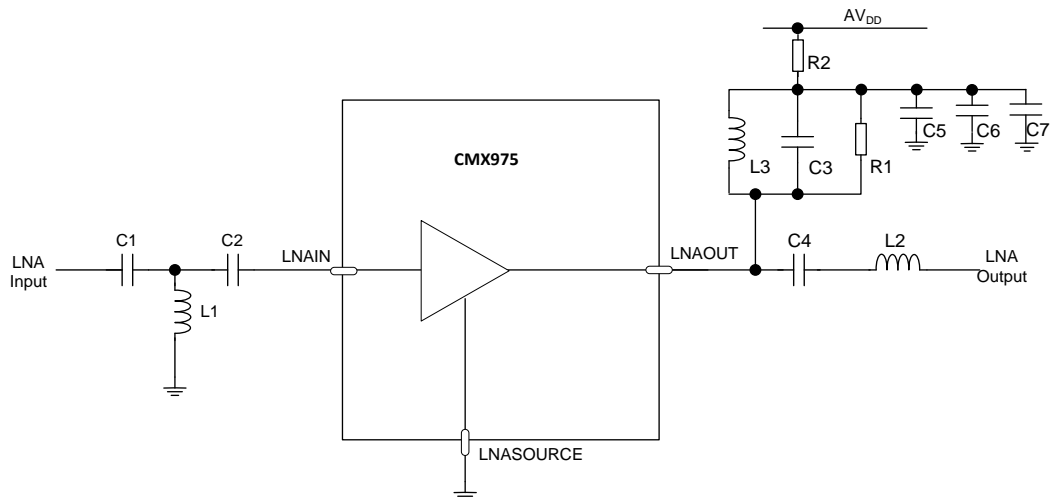

Figure 16 LNA External Components (1.5GHz to 2.7GHz)

Reference	1GHz	1.5GHz	2.7GHz
C1	1.2pF	1pF	6.8pF
C2	47pF	22pF	3.6 nH (0402HP)
C3	1.5pF	1.5pF	-
C4	47pF	22pF	6.2 nH (0402HP)
C5	100pF	47pF	100pF
C6 *	1nF	1nF	1nF
C7 *	100pF	47pF	100pF
L1	9.5nH (0402HP)	4,7 nH (0402HP)	1.0 pF
L2	15nH (0402HP)	8.7 nH (0402HP)	6.8 pF
L3	15nH (0402HP)	4.7 nH (0402HP)	5.1 nH (0402HP)
R1	180Ω	330Ω	270Ω
R2	3.3Ω	3.3 Ω	3.3 Ω

Table 15 LNA Components

* Note: for optimum performance please refer to the section describing the LNA in the EKDS.

7.6 RF VCO and Fractional-N PLL

The RF Synthesiser is a programmable 6GHz fractional-N PLL and VCO; a block diagram of the synthesiser is shown in Figure 17. A 1.2V voltage regulator provides the supply required for the synthesiser. The synthesiser can use either the external LOIN signal (700MHz to 6GHz) or the output of the internal RF VCO (2.8GHz to 3.6GHz). As well as extending the upper frequency limit to 6GHz, using an external VCO enables the device to cover other frequencies than the bands covered when using the internal VCO.

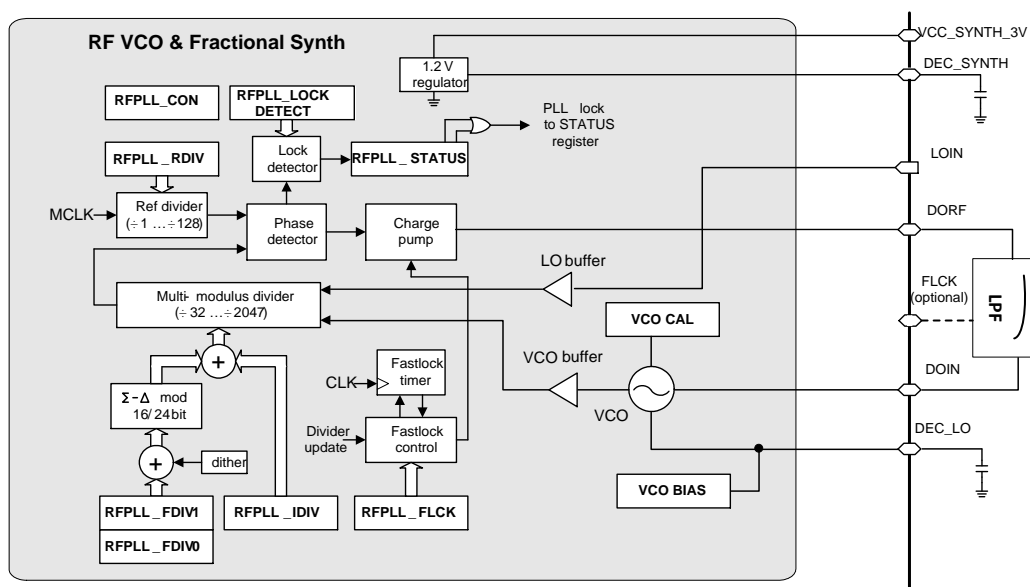

Figure 17 Fractional-N Frequency Synthesiser

7.6.1 RF Fractional-N Synthesiser

The RF Synthesiser uses a sigma-delta modulation technique that allows use of a high reference frequency, thus providing rapid frequency switching and low phase noise performance. The 24-bit fractional divider resolution provides an ultra-fine step size that may be useful in narrowband applications, or can be used to compensate for crystal oscillator frequency drift, Doppler shift, etc.

A fast locking mechanism is provided that increases the transition rate when changing to a new operating frequency. This is done by temporarily modifying the loop filter characteristics and charge pump gain whenever the main divider settings are updated, allowing the responsiveness of the closed loop system to be increased without compromising the loop

stability. The fast lock mode automatically turns off after a predetermined delay, returning the PLL to its standard, low noise mode of operation.

The RF synthesiser has a programmable lock detector circuit that indicates when the loop is in lock. The lock detectors can be configured for analogue or digital operation and no external components are required, a programming example is given in section 9. The registers associated with initialisation of the RF synthesiser are:

- GCR - \$31
- GCR_RD - \$C1

The registers used to configure the RF Synthesiser are:

- RFPLL_CON - \$34
- RFPLL_BLEED - \$35
- RFPLL_LOCKDET - \$36
- RFPLL_FLCK - \$37
- RFPLL_RDIV - \$38
- RFPLL_RDIV_RD - \$C8
- RFPLL_IDIV - \$39
- RFPLL_IDIV_RD - \$C9
- RFPLL_FDIV0 - \$3A
- RFPLL_FDIV0_RD - \$CA
- RFPLL_FDIV1 - \$3B
- RFPLL_FDIV1_RD - \$CB
- LO_CONTROL - \$3F
- LO_CONTROL_RD - \$CF

Control of the RF Synthesiser is via the following registers:

- POWER_STATUS - \$C6
- DEVICE_STATUS - \$C4
- IRQ_ENABLE - \$C5

7.6.2 Register Loading Order

To use the RF Synthesiser, the registers must be loaded in the order specified below.

The RF PLL enable bit (General Control Register (\$31) bit 2) should be set to power up the synthesiser and MCLK amplifier (note: the charge pump output will remain in a high impedance state until the main divider registers are loaded).

Registers RFPLL_CON, RFPLL_LOCKDET, RFPLL_FLCK and RFPLL_RDIV should be initialised before the main divider registers are loaded for the first time.

After the main divider registers are loaded, the RF Synthesiser begins operating. The main divider registers can be changed at any subsequent time, but must always be updated in the following order:

Integer-N mode:

Load RFPLL_IDIV with the desired value, at which point the new divide ratio will take effect.

Fractional-N mode, 16-bit fractional resolution:

Load RFPLL_IDIV (if necessary), then load RFPLL_FDIV0. The new divide ratio only takes effect when RFPLL_FDIV0 is loaded.

Fractional-N mode, 24-bit fractional resolution:

Load RFPLL_IDIV and RFPLL_FDIV1 (if necessary), then load RFPLL_FDIV0. The new divide ratio only takes effect when RFPLL_FDIV0 is loaded.

If fastlock is enabled (\$36, b12='1') each time the main divider registers are updated at the point when the new divide ratio takes effect a fastlock sequence is triggered.

7.6.3 Fractional-N Programming Example

The PLL functions are shown in Figure 17. The output frequency of the PLL is set by the following calculation:

$$f_{out} = f_{ref} \times (N / R)$$

where:

- f_{out} = The desired output frequency in MHz
- f_{ref} = The reference frequency supplied to the PLL on pin MCLK in MHz
- N = Divider value programmed in the N divider registers (This then comprises of Integer and Fractional components, see sections 8.5.6 to 8.5.8)
- R = Divider value programmed in the R divider register (see section 8.5.5)

Also note that the comparison frequency $f_{comp} = f_{ref} / R$

To operate the RFPLL in 24-bit fractional mode with an internal VCO frequency $f_{VCO} = 3525.05\text{MHz}$, a master clock frequency $f_{MCLK} = 38.4\text{MHz}$, and a PLL comparison frequency $f_{COMP} = 19.2\text{MHz}$.

$$Rdiv = f_{MCLK} \div f_{COMP} = 38.4\text{MHz} \div 19.2\text{MHz} = 2$$

$$Ndiv = f_{VCO} \div f_{COMP} = 3525.05\text{MHz} \div 19.2\text{MHz} = 183.5963542$$

Split the N divider value into integer and fractional parts:

$$Idiv = \text{Round}(183.5963542) = 184 \text{ (decimal)} = 0x00B8 \text{ (hex)}$$

$$Fdiv \text{ (24-bit mode)} = \text{Round}(2^{24} \times (Ndiv - Idiv)) = -6772053 \text{ (decimal)} = 0x98AAAB \text{ (hex)}$$

Load C-BUS registers:

GCR, bit 2 = 1(enable RF PLL)

RFPLL_CON

bit 14-11 = 1101 (fractional N-divider with 3rd order max length MASH 1-1-1 post-filtered modulator)

bit 9 = 0 (24-bit resolution)

Set RFPLL_LOCKDET and RFPLL_FLCK as desired

RFPLL_RDIV = 0x02

RFPLL_IDIV = 0x00B8

RFPLL_FDIV1 = 0x98

RFPLL_FDIV0 = 0xAAAB

At this point, the charge pump is enabled and RFPLL begins to acquire lock. The frequency step size in this example is $19.2\text{MHz} \div 2^{24} \approx 1.14\text{Hz}$.

7.6.4 Loop Filter

An external loop filter is connected as shown in Figure 18 and Table 16.

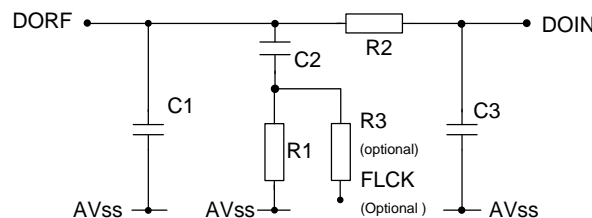

Figure 18 Example External Components – VCO External Loop Filter

VCO Frequency	Fcomp	C1	C2	C3	R1	R2	R3 (optional FLCK)
2.925GHz	19.2MHz	750pF	6.2nF	27pF	1.6kΩ	5.1kΩ	See section 8.5.4
3.0GHz	4.8MHz	680pF	5.6nF	27pF	2.2kΩ	5.6kΩ	See section 8.5.4
3.5GHz	19.2MHz	470pF	3.6nF	22pF	2.4kΩ	6.8kΩ	See section 8.5.4

Table 16 3rd Order Loop Filter Example Values

Note: C1, C2, C3, R1 and R2 assume a $K_{vco}=70\text{MHz/V}$, $I_{cp}=400\mu\text{A}$. The 3.0GHz example is as per the worked example in section 9.2.1 and these are the default values used on evaluation kits.

7.6.5 RF VCO

The internal RF VCO consists of a negative resistance core cell, inductor, fine and coarse capacitor tuning banks, biasing and calibration circuits.

7.6.5.1 RF VCO Calibration

After configuring the RF PLL divider settings and enabling the RF PLL, the on-chip VCO bias and RF VCO should be calibrated. The device is instructed to calibrate the VCO bias current by setting b0 in the VCO_CAL_CTRL (\$50) register with b15-b8 set to the MCLK frequency in MHz. The loop comparison frequency during calibration should be 4.8MHz or greater. The reference divider can be changed after calibration, if required. The calibration status may be monitored by reading the VCO_CAL_STAT (\$5E) register. When calibration has completed, the 5-bit VCO bias calibration value may be read from the VCO_BIAS_CAL_READ (\$5B) register.

Following VCO bias current calibration, the device should be instructed to calibrate the RF VCO resonant frequency by setting b1 in the VCO_CAL_CTRL (\$50) register. The calibration status may be read from the VCO_CAL_STAT (\$5E) register and, when calibration has completed, the 9-bit RF VCO calibration value may be read from the RFVCO_CAL_READ (\$5C) register. The calibration of the VCO bias and RF VCO may be simultaneously requested by setting b0 and b1 in the VCO_CAL_CTRL (\$50) register. In this case, the device will first perform calibration of the VCO bias followed by calibration of the RF VCO.

The registers used during RF VCO calibration are:

- VCO_BIAS_CAL_WRITE - \$51
- VCO_BIAS_CAL_READ - \$5B
- VCO_BIAS_CAL_TIME - \$52
- RFVCO_CAL_WRITE - \$53
- RFVCO_CAL_READ - \$5C
- RFVCO_CAL_COUNT - \$54
- RFVCO_CAL_TIME - \$55
- RFVCO_STARTUP_TIME - \$56
- LO_CONTROL - \$3F
- LO_CONTROL_RD - \$CF

Control of the RFVCO is via the following registers:

- VCO_CAL_CTRL - \$50
- VCO_CAL_STAT - \$5E
- DEVICE_STATUS - \$C4
- IRQ_ENABLE - \$C5

7.6.5.2 RF VCO Calibration Duration

The total calibration duration of the RF VCO in μs , $t_{\text{rf-cal}}$, is approximately given by the following equation:

$$t_{\text{rf-cal}} \approx 6 \cdot t_{\text{bias}} + t_{\text{rf-start-up}} + 6 \cdot t_{\text{rf-open-loop}} \cdot R_{\text{rf-rdiv}} / f_{\text{MCLK}} + t_{\text{rf-settle}} + 4 \cdot t_{\text{rf-close-loop}}$$

where:

$$t_{\text{bias}} = \text{VCO_BIAS_CAL_TIME} (\$52) \text{ register b5-b0 } (\mu\text{s}).$$

$$t_{\text{rf-start-up}} = \text{RFVCO_STARTUP_TIME} (\$56) \text{ register b11-b0 } (\mu\text{s}).$$

$$t_{\text{rf-open-loop}} = \text{RFVCO_CAL_COUNT} (\$54) \text{ register b9-b0}.$$

$$R_{\text{rf-rdiv}} = \text{RFPLL_RDIV} (\$38) \text{ register b6-b0}.$$

$$f_{\text{MCLK}} = \text{MCLK frequency (MHz)}.$$

$$t_{\text{rf-settle}} = \text{RFVCO_CAL_TIME} (\$55) \text{ register b15-b8 } (x8\mu\text{s}).$$

$$t_{\text{rf-close-loop}} = \text{RFVCO_CAL_TIME} (\$55) \text{ register b7-b0 } (x8\mu\text{s}).$$

For example, assuming a 3500MHz RF VCO with 19.2MHz comparison frequency:

$$t_{\text{bias}} = 6\mu\text{s}$$

$$t_{\text{rf-start-up}} = 300\mu\text{s}$$

$$t_{\text{rf-open-loop}} = 350$$

$$R_{\text{rf-rdiv}} = 1$$

$$f_{\text{MCLK}} = 19.2\text{MHz}$$

$$t_{\text{rf-settle}} = 104\mu\text{s}$$

$$t_{\text{rf-close-loop}} = 48\mu\text{s}$$

Therefore,

$$t_{\text{rf-cal}} \approx 6 \times 6 + 300 + 6 \times 350 \times 1 / 19.2 + 104 + 4 \times 48 \approx 742 \mu\text{s}$$

7.6.5.3 RF VCO Calibration Indicators

The RF VCO calibration indicators signal to the host that the RF VCO should be recalibrated for optimum phase noise performance due to temperature or supply voltage change since the last calibration.

The RF VCO recalibration indicators may be read from the DEVICE_STATUS (\$C4) register - bits 6/5 indicate if the RF VCO is running too slow/fast.

How often the DEVICE_STATUS (\$C4) register should be read depends on the change in temperature and voltage since the last calibration, which will be application dependent.

If any of the RF VCO calibration indicators are high, the host should perform one of the following two actions:

1. Initiate a full recalibration of the VCO bias current and RF VCO resonant frequency by setting b1 and b0 of VCO_CAL_CTRL (\$50).
2. Initiate a recalibration of the VCO bias current by setting b0 of VCO_CAL_CTRL (\$50). The RF VCO resonant frequency may be subsequently increased/decreased if required by manually increasing/decreasing the RF VCO calibration code. The present RF VCO calibration code may be read from the RFVCO_CAL_READ (\$5C) register. The new RF VCO calibration code may be written to the RF VCO_CAL_WRITE (\$53) register. When the RF VCO is too slow/fast the calibration code should be increased/decreased until the RF VCO calibration indicators are all low. This method is much faster than initiating a full recalibration of the RF VCO.

7.7 IF PLL and VCO

7.7.1 IF PLL

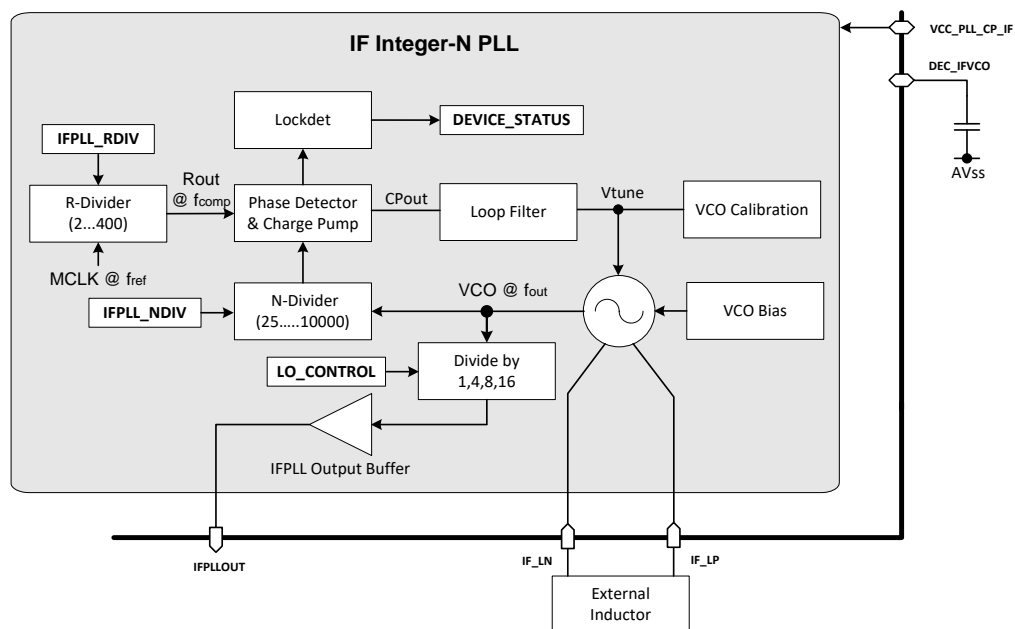

Figure 19 IF PLL Architecture

The IF PLL is an integer-N type and the functions are shown in Figure 19. The output frequency of the PLL is set by the following calculation:

$$f_{\text{out}} = f_{\text{ref}} \times (N / R)$$

where:

f_{out} = The desired output frequency in MHz

f_{ref} = The reference frequency supplied to the PLL on pin MCLK in MHz

N = Divider value programmed in the N divider register (see section 8.6.1)

R = Divider value programmed in the R divider register (see section 8.6.2)

also note that the comparison frequency $f_{\text{comp}} = f_{\text{ref}} / R$

The IF PLL provides a lock detect function which can be read via the DEVICE_STATUS (\$C4) register, see section 8.9.1.

Initialisation of the IF Synthesiser is via the following registers:

- GCR - \$31
- GCR_RD - \$C1

Configuration of the IF Synthesiser is via the following registers:

- IFPLL_NDIV - \$3C
- IFPLL_NDIV_RD - \$CC
- IFPLL_RDIV - \$3D
- IFPLL_RDIV_RD - \$CD
- IFPLL_CURRENT - \$3E
- IFPLL_CURRENT_RD - \$CE

Control of the IF Synthesiser is via the following registers:

- POWER_STATUS - \$C6
- DEVICE_STATUS - \$C4
- IRQ_ENABLE - \$C5

7.7.2 Programming Example

To operate the IF PLL with a VCO frequency $f_{VCO} = 900\text{MHz}$, a master clock frequency $f_{MCLK} = 38.4\text{MHz}$, and a PLL comparison frequency $f_{COMP} = 1.2\text{MHz}$.

$$\text{IF PLL Rdiv} = f_{MCLK} \div f_{COMP} = 38.4\text{MHz} \div 1.2\text{MHz} = 32 \text{ (dec)} = 0x 0020$$

$$\text{IF PLL Ndiv} = f_{VCO} \div f_{COMP} = 900\text{MHz} \div 1.2\text{MHz} = 750 \text{ (dec)} = 0x 02EE$$

The VCO frequency can then be further divided if required via the LO_CONTROL IFPLLDIV bits (see section 8.8.1).

7.7.3 IF VCO

The IF VCO is a reflection oscillator that requires an external resonator circuit to set its operating frequency. Table 17 gives the IF VCO external inductor value for a given centre frequency. The IF VCO frequency is intended to be essentially fixed apart from a small tuning range $\pm 20\text{MHz}$ (e.g. to give a small shift between Tx and Rx); the full tuning capability can then be used to compensate for process, voltage and temperature (PVT) variation and for practical choice of inductor. The following table gives the IF VCO external inductor value for a given centre frequency.

Typical Centre Frequency & Approximate Tuning Range (MHz)	Inductor value (nH)
520 (~ 410- 640)	30
780 (~ 600-960)	12
900 (~ 680-1100)	8.2
1015 (~ 800-1250)	5.6
1170 (~ 900-1450)	3.6

Table 17 External Inductor Values for IF Centre Frequencies

Notes:

- The above inductor values assume that there is about 2.5mm of PCB track length from each chip output to the corresponding inductor pad.
- The on-chip capacitance can typically be changed from 5pF to 1.6pF with 1.2V on the VCO control voltage (V_{tune}) by changing the VCO Calibration Code.
- The approximate external inductor value can be selected by use of the following equation:

$$f_{\text{centre}} = \frac{1}{2\pi\sqrt{(5.8\text{nH} + L_{\text{ext}})2.6\text{pF}}}$$

where:

- 5.8nH is the value of the package and typical PCB inductance
- 2.6pF is the on-chip capacitance at the given centre frequency with 1.2V on the VCO control voltage.

It is recommended that the frequency of oscillation be measured at the highest and lowest code and an inductor chosen to give a median frequency between these two measured values.

The frequency and capacitance variation due to the analogue control voltage is much less than due to the VCO Calibration Code and the varactor is chosen to give a VCO gain of typically 11MHz/V at 900MHz. The VCO gain scales approximately

linearly with frequency and the measured gain is typically 13MHz/V and 4.0MHz/V at 1GHz and 680MHz, respectively, using a 8.2 nH external inductor.

7.7.3.1 IF VCO Calibration

IF VCO calibration is configured with the following registers:

- VCO_BIAS_CAL_WRITE - \$51
- VCO_BIAS_CAL_READ - \$5B
- VCO_BIAS_CAL_TIME - \$52
- IFVCO_CAL_WRITE - \$57
- IFVCO_CAL_READ - \$5D
- IFVCO_CAL_COUNT - \$58
- IFVCO_CAL_TIME - \$59
- VCO_CAL_CTRL - \$50
- VCO_CAL_STAT - \$5E
- DEVICE_STATUS - \$C4
- IRQ_ENABLE - \$C5

After configuring the IF PLL divider settings and enabling the IF PLL, the on-chip VCO bias and IF VCO should be calibrated. The device is instructed to calibrate the VCO bias current by setting b0 in the VCO_CAL_CTRL (\$50) register with b15-b8 set to the MCLK frequency in MHz. The calibration status may be monitored by reading the VCO_CAL_STAT (\$5E) register. When calibration has completed, the 5-bit VCO bias calibration value may be read from the VCO_BIAS_CAL_READ (\$5B) register.

Following VCO bias current calibration, the device should be instructed to calibrate the IF VCO resonant frequency by setting b2 in the VCO_CAL_CTRL (\$50) register. The calibration status may be read from the VCO_CAL_STAT (\$5E) register and, when calibration has completed, the 9-bit IF VCO calibration value may be read from the IFVCO_CAL_READ (\$5D) register.

The calibration of the VCO bias and IF VCO may be simultaneously requested by setting b0 and b2 in the VCO_CAL_CTRL (\$50) register. In this case, the device will first perform calibration of the VCO bias followed by calibration of the IF VCO.

7.7.3.2 IF VCO Calibration Duration

The total calibration duration of the IF VCO in μs , $t_{\text{if-cal}}$, is approximately given by the following equation:

$$t_{\text{if-cal}} \approx 6 \cdot t_{\text{bias}} + t_{\text{if-start-up}} + 7 \cdot t_{\text{if-open-loop}} \cdot R_{\text{if-rdiv}} / f_{\text{MCLK}} + t_{\text{if-settle}} + 3 \cdot t_{\text{if-close-loop}}$$

where:

- t_{bias} = VCO_BIAS_CAL_TIME (\$52) register b5-b0 (μs).
- $t_{\text{if-start-up}}$ = IFVCO_STARTUP_TIME (\$5A) register b11-b0 (μs).
- $t_{\text{if-open-loop}}$ = IFVCO_CAL_COUNT (\$58) register b9-b0.
- $R_{\text{if-rdiv}}$ = IFPLL_RDIV (\$3D) register b8-b0.
- f_{MCLK} = MCLK frequency (MHz).
- $t_{\text{if-settle}}$ = IFVCO_CAL_TIME (\$59) register b15-b8 ($x8\mu\text{s}$).
- $t_{\text{if-close-loop}}$ = IFVCO_CAL_TIME (\$59) register b7-b0 ($x8\mu\text{s}$).

For example, assuming a 900MHz IF VCO with 1.92MHz comparison frequency:

$$\begin{aligned} t_{\text{bias}} &= 6\mu\text{s} \\ t_{\text{if-start-up}} &= 325\mu\text{s} \\ t_{\text{if-open-loop}} &= 450 \\ R_{\text{if-rdiv}} &= 10 \\ f_{\text{MCLK}} &= 19.2\text{MHz} \\ t_{\text{if-settle}} &= 104\mu\text{s} \\ t_{\text{if-close-loop}} &= 104\mu\text{s} \end{aligned}$$

Therefore,

$$t_{\text{if-cal}} \approx 6 \times 6 + 325 + 7 \times 450 \times 10 / 19.2 + 104 + 3 \times 104 \approx 2418\mu\text{s}$$

7.7.3.3 IF VCO Calibration Indicators

The IF VCO calibration indicators signal to the host that the VCO should be recalibrated for optimum phase noise performance due to temperature or supply voltage change since the last calibration.

The IF VCO recalibration indicators may be read from the DEVICE_STATUS (\$C4) register - bits 4/3 indicate if the IF VCO is running too slow/fast.

How often the DEVICE_STATUS (\$C4) register should be read depends on the change in temperature and voltage since the last calibration, which will be application dependent.

If any of the IF VCO calibration indicators are high, the host should perform one of the following two actions:

1. Initiate a full recalibration of the VCO bias current and IF VCO resonant frequency by setting b2 and b0 of VCO_CAL_CTRL (\$50).
2. Initiate a recalibration of the VCO bias current by setting b0 of VCO_CAL_CTRL (\$50). The IF VCO resonant frequency may be subsequently increased/decreased if required by manually increasing/decreasing the IF VCO calibration code. The present IF VCO calibration code may be read from the IFVCO_CAL_READ (\$5D) register. The new IF VCO calibration code may be written to the RF VCO_CAL_WRITE (\$57) register. When the IF VCO is too slow/fast the calibration code should be increased/decreased until the IF VCO calibration indicators are all low. This method is much faster than initiating a full recalibration of the IF VCO.

7.7.4 IF PLL Output

The IFPLL output impedance is independent of divider setting and is high, typically 8 k Ω in parallel with 0.5pF. Figure 20 and Table 18 show the VCO output buffer matching components required when evaluated with 50 Ω measurement equipment at 900MHz. Note that the high impedance cannot be easily matched to 50 Ω without some resistive loading, however matching does provide a higher output level (4dB in the example given). Note that a DC blocking capacitor at the IFPLLOUT pin is required.

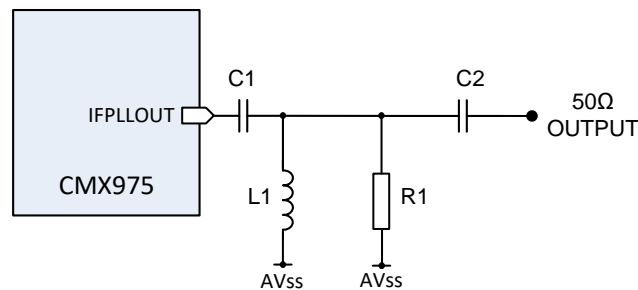

Figure 20 Typical Matching Values for 900MHz (850 to 950 MHz)

C1	C2	L1	R1
100pF	1.2pF	13nH	680 Ω

Table 18 Typical Matching Components for 900MHz (850 to 950 MHz)

Note 1: the components shown provide a 50 Ω match over 850 to 950 MHz.

Note 2: When driving the CMX973, the signal may be high enough without matching components except for the dc blocking capacitor, which is required.

Note 3: for matching values for the divide by 4/8/16 frequency ranges consult CML Technical Support.

7.7.5 IF PLL Divider

The IF PLL divider is provided for applications that require a common IF frequency that is less than the minimum VCO frequency of 500MHz, the divider options are shown in Table 19.

The divider value is set via the LO CONTROL (\$3F) register b5-b4 (section 8.8.1).

LO_CONTROL b5-b4	Divider Value
00	1
01	4
10	8
11	16

Table 19 IF VCO Divider Settings

7.8 Local Oscillator (LO)

The CMX975 can use the internal VCO or an external VCO. Five bits in the General Control Register and one bit in the Tx Control Register are used to define the allowed states (X = don't care). Valid combinations are shown in Table 20.

The LO is controlled by the following registers:

- GCR - \$31
- GCR_RD - \$C1
- LO_CONTROL - \$3F
- LO_CONTROL_RD - \$CF

LOOUT (\$31, b6)	ENEXTVCO (\$31, b3)	RFPLEN (\$31, b2)	RXEN (\$31, b1)	TXEN (\$31, b0)	S (\$34, b8)	Rx Mixer LO input	Tx Mixer LO input	PLL & Output
1	1	0	0	0	X	-	-	LOIN pin connected to LOOUT Pin
0	0	1	0	0	X	-	-	VCO output connected to PLL
1	0	1	0	0	X	-	-	VCO output connected to PLL and LOOUT Pin
0	1	0	1	0	X	Connected to LOIN pin	-	-
0	1	1	1	0	X	Connected to LOIN pin	-	PLL connected to LOIN pin
0	0	1	1	0	X	Connected to internal VCO	-	PLL connected to internal VCO
0	1	0	0	1	X	-	Connected to LOIN pin	-
0	1	1	0	1	X	-	Connected to LOIN pin	PLL connected to LOIN pin
0	0	1	0	1	X	-	Connected to internal VCO	PLL connected to internal VCO
1	1	0	1	0	X	Connected to LOIN pin	-	LOIN pin connected to LOOUT Pin
1	1	1	1	0	X	Connected to LOIN pin	-	PLL and LOOUT connected to LOIN pin.
1	0	1	1	0	X	Connected to internal VCO	-	PLL and LOOUT connected to internal VCO
1	1	0	0	1	X	-	Connected to LOIN pin	LOIN pin connected to LOOUT Pin
1	1	1	0	1	X	-	Connected to LOIN pin	PLL and LOOUT connected to LOIN pin.
1	0	1	0	1	X	-	Connected to internal VCO	PLL and LOOUT connected to internal VCO
0	1	0	1	1	X	Connected to LOIN pin	Connected to LOIN pin	Duplex Mode-
0	1	1	1	1	X	Connected to LOIN pin	Connected to LOIN pin	Duplex Mode PLL connected to internal LOIN pin
0	0	1	1	1	0	Connected to internal VCO	Connected to LOIN pin	Duplex Mode PLL connected to internal VCO

LOOUT (\$31, b6)	ENEXTVCO (\$31, b3)	RFPLEN (\$31, b2)	RXEN (\$31, b1)	TXEN (\$31, b0)	S (\$34, b8)	Rx Mixer LO input	Tx Mixer LO input	PLL & Output
0	0	1	1	1	1	Connected to LOIN pin	Connected to internal VCO	Duplex Mode PLL connected to internal VCO

Notes:

1. Attempts to set combinations of bits not shown in the table will have no effect.
2. The LO output (LOUT pin) cannot be used in duplex mode (Rx and Tx mixers both enabled).
3. The LOOUT pin (when enabled) is always connected via the selectable divider.

Table 20 LO Connections

7.8.1 LO Input (LOIN)

The CMX975 has a single-ended external LO input with a frequency range from 700MHz to 6GHz. Users should be aware that the presence of high levels of harmonics in the signals applied to the LO inputs might degrade quadrature accuracy when image reject operation is selected. The LOIN is a common gate input requiring a dc bias from ground and an input match as shown in Figure 21 and Table 21 LOIN Match Components.

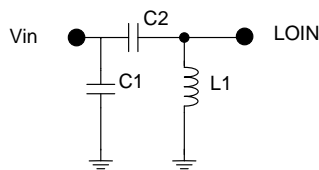

Figure 21 LOIN Match Components

LOIN Frequency	C1	C2	L1	Comments
5-5.5GHz	0.5pF Murata GRM1555C1HR50CZ01	Shorted	1.2nH Coilcraft 0402CS-1N2	PCB should omit C2 footprint. Place C1 in parallel with L1 for 5.5 – 6.0 GHz operation.
3.45-3.65GHz	1.1pF Murata GRM1555C1H1R1CZ01	3.6pF Murata GRM1555C1H3R6CZ01	1.2nH Coilcraft 0402CS-1N2	For LO high side RX/TX=1.5/1.6GHz
1.15GHz	2.2pF Murata GRM1555C1H2R2CZ01	7.5pF Murata GRM1555C1H7R5DZ01	7.5nH Coilcraft 0402CS-7N5	For Single Mixers TX/RX=1GHz
700 MHz – 4 GHz	Not Fitted	8.2 pF	12 nH Coilcraft 0402CS	Broadband match

Table 21 LOIN Match Components

7.8.2 LO Output (LOOUT)

The CMX975 has a single-ended LOOUT with a frequency range from 337.5MHz to 3.6GHz. The output can be configured to internally divide the signal by 1/2/4/6/8 before it reaches LOOUT. Using the LO Output dividers the following frequency ranges are available using the RF VCO:

Divider value	1	2	4	6	8
F Low MHz	2800	1400	700	466.67	350
F High MHz	3600	1800	900	600	450

Table 22 RF VCO Frequency Limits with LO Output Divider Value

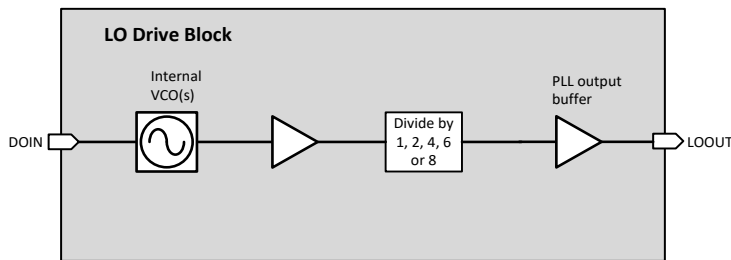

Figure 22 LO Drive Block Schematic

The LO output is designed to operate with a 50Ω load but presents an impedance of typically 130 Ω in parallel with 1 pF. A typical output match from LOOUT is shown in Figure 23 and Table 23. The L-match produced by L1 and C2 loads the LOOUT port with approximately 120Ω, while C1 provides AC coupling. The matching (L1/C2) can be omitted resulting in a reduced output level. In practice, the narrow tracking required to the LOOUT pin is sufficient to provide a good match to 50Ω in the divide by 1 setting. The use of matching for the divided outputs can improve the levels of LO harmonics.

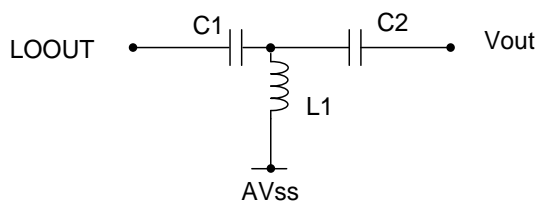

Figure 23 LOOUT Matching Components

Frequency	3200 MHz (divide 1)	1600 MHz (divide 2)	800 MHz (divide 4)	535 MHz (divide 6)	400 MHz (divide 8)
C1	3.9 pF	22 pF	100 pF	180 pF	470 pF
C2	0Ω	2.2 pF	5.6 pF	5.6 pF	8.2 pF
L1	Not Fitted	5.6 nH	12nH	18 nH	30 nH

Note: C1 is selected to be at its series resonant frequency at the LOOUT frequency. Inductor values are from the Coilcraft 0402CS series.

Table 23 LOOUT Matching Typical Values

7.8.3 Dividers and LO Output

Dividers are provided as part of the operation of the mixers, offering /1, /2 or /4 operation (/1 not available in image reject modes). The divider options are separately selectable for the Tx and Rx mixers.

A separate LO output is also provided. In order to make this as flexible as possible, /1, /2, /4, /6 and /8 settings are available on the LO output when the LO source is the internal VCO; /2, /4, /6, /8 settings are available on the LO output when the source is the external VCO. See Figure 24 for further information.

The LO output is designed to operate with a 50Ω load, however, the output signal level can be increased by matching the LO port at the required operating frequency.

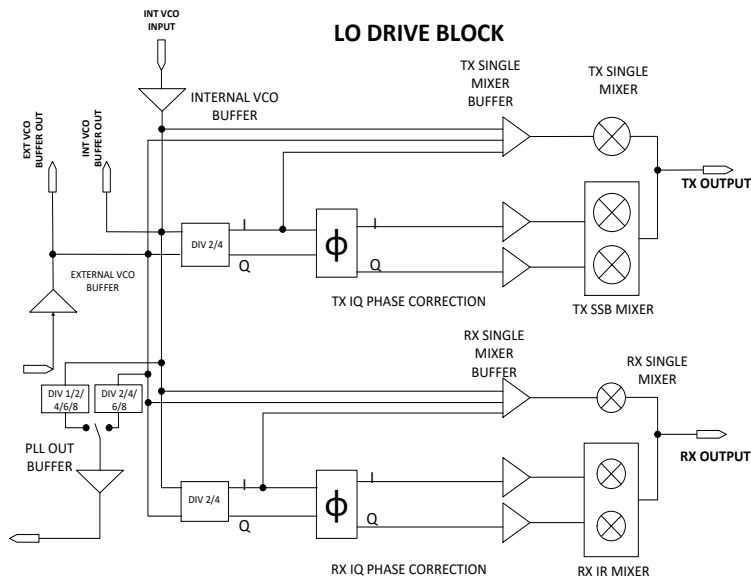

Figure 24 LO Drive Block Schematic

Using the LO Output dividers, the following frequency ranges are available using the internal RF VCO.

Divider value	1	2	4	6	8
F Low MHz	2800	1400	700	466.67	350
F High MHz	3600	1800	900	600	450

Table 24 RF Internal VCO Frequency Limits with LO Output Divider Value

7.9 Status and Interrupts

The status register (\$C4) indicates the status of the RFPLL lock, the IFPLL lock, the clock-ready status and the RF/IF VCO comparator status signals. The interrupt enable register allows each of the status bits (or combination thereof) to generate an interrupt on the IRQN pin.

The lock signals from the PLLs are real-time indications of lock status and will be set immediately the PLL attains/regains lock and clear immediately the PLL loses lock. Consequently, if the lock status is enabled for interrupt, the IRQN pin may de-activate before the status register is read.

There is a third lock status bit which is an AND of the 2 individual PLL lock bits, thus creating a “both in lock” status bit. If only this status bit is enabled for interrupt, the IRQN will behave similarly to a dedicated “in lock” pin (active low). The clock ready status bit can be interrogated by the user to ensure the digital clock is running prior to issuing C-BUS commands that rely on an active clock.

8 Register Description and C-BUS Interface

The C-BUS serial interface supports the transfer of data and control or status information between the CMX975's internal registers and an external host. Each C-BUS transaction consists of the host sending a single Register Address byte, which may then be followed by zero or more data bytes that are written into the corresponding CMX975 register.

Data sent from the host on the Command Data (CDATA) line is clocked into the CMX975 on the rising edge of the Serial Clock (SCLK) input. The C-BUS interface is compatible with common μ C/DSP serial interfaces and may also be easily implemented with general purpose I/O pins controlled by a simple software routine. Section 3.1.3.7 gives the detailed C-BUS timing requirements.

Whether a C-BUS register is of read or write type, it is fixed for a given C-BUS register address, thus one cannot both read and write the same C-BUS register address.

In order to provide ease of addressing when using this device with other CML RF devices, the C-BUS addresses below are arranged so as not to overlap those used on the existing CML RF Devices. Thus, a common chip select (CSN) signal can be used, as well as common CDATA, RDATA and SCLK signals.

The following C-BUS register addresses are used:

Table 25 C-BUS Register Map

R/W	Size (bits)	Description	Address
W	0	GEN_RST (Address only, no data)	\$30
W	8	GCR	\$31
W	16	RX_CON	\$32
W	8	TX_CON	\$33
W	16	RFPLL_CON	\$34
W	8	RFPLL_BLEED	\$35
W	16	RFPLL_LOCKDET	\$36
W	16	RFPLL_FLCK	\$37
W	8	RFPLL_RDIV	\$38
W	16	RFPLL_IDIV	\$39
W	16	RFPLL_FDIV0	\$3A
W	8	RFPLL_FDIV1	\$3B
W	16	IFPLL_NDIV	\$3C
W	16	IFPLL_RDIV	\$3D
W	8	IFPLL_CURRENT	\$3E
W	8	LO_CONTROL	\$3F
W	8	VCO_CAL_CTRL	\$50
W	8	VCO_BIAS_CAL_WRITE	\$51
W	8	VCO_BIAS_CAL_TIME	\$52
W	16	RFVCO_CAL_WRITE	\$53
W	16	RFVCO_CAL_COUNT	\$54
W	16	RFVCO_CAL_TIME	\$55
W	16	RFVCO_STARTUP_TIME	\$56
W	16	IFVCO_CAL_WRITE	\$57
W	16	IFVCO_CAL_COUNT	\$58
W	16	IFVCO_CAL_TIME	\$59
W	16	IFVCO_STARTUP_TIME	\$5A
R	8	VCO_BIAS_CAL_READ	\$5B
R	16	RFVCO_CAL_READ	\$5C
R	16	IFVCO_CAL_READ	\$5D
R	8	VCO_CAL_STAT	\$5E
R	8	GCR_RD	\$C1
R	8	RX_CON_RD	\$C2
R	8	TX_CON_RD	\$C3
R	8	DEVICE_STATUS	\$C4
W	8	IRQ_ENABLE	\$C5
R	8	POWER_STATUS	\$C6
R	8	RFPLL_RDIV_RD	\$C8
R	16	RFPLL_IDIV_RD	\$C9

R/W	Size (bits)	Description	Address
R	16	RFPLL_FDIV0_RD	\$CA
R	8	RFPLL_FDIV1_RD	\$CB
R	16	IFPLL_NDIV	\$CC
R	16	IFPLL_RDIV_RD	\$CD
R	8	IFPLL_CURRENT_RD	\$CE
R	8	LO_CONTROL_RD	\$CF

Notes:

- All registers will retain data if DVDD pin is held high, even if all other power supply pins are disconnected.
- The digital interface can run at a lower voltage than the rest of the device by setting the DV_{DD} supply to the required interface voltage, see section 3.1.2.
- If clock and data lines are shared with other devices DV_{DD} must be maintained in its normal operating range, otherwise ESD protection diodes may cause a problem with loading signals connected to SCLK, RDATA and CDATA pins, preventing correct programming of other devices. Other supplies may be turned off and all circuits on the device may be powered down without causing this problem.

8.1 General Reset Command

8.1.1 GEN_RST - \$30

(no data)

This command resets the device and clears all bits of all registers. The General Reset command places the device into Powersave mode.

See also section 7.1.

8.2 General Control Register

8.2.1 GCR - \$31

8-bit Write

Reset value: \$00

This register controls general features such as Powersave.

All bits of this register are cleared to '0' during a General Reset command.

7	6	5	4	3	2	1	0
LNAEN	LOOUT	IFPLEN	ENBIAS	ENEXTVCO	RFPLEN	RXEN	TXEN

GCR b7: LNA Enable

0: LNA disabled, 1: LNA enabled.

GCR b6: LO Output Enable

0: LO output disabled, 1: LO output enabled.

To enable the LO output, the LO Control Register (\$3F) b2-0 must be set to a legal value other than '000' divider off.

GCR b5: IF PLL Enable

0: IF PLL disabled, 1: IF PLL enabled.

GCR b4: Bias Pre-enable

0: Bias pre-enable off, 1: Bias pre-enable on.

Setting this bit to "1" enables the bias block, which may be done ahead of enabling any of the functional blocks. This will reduce the overall turn-on time for any functional block. The bias block is also enabled when any of the functional blocks are enabled, although the turn-on time will be longer, as both the bias block and the functional block need to turn on. Under this condition, bit 4 will remain cleared to '0'.

GCR b3: External VCO Input Enable

0: External VCO Input disabled, 1: External VCO Input enabled.

Note: the internal VCO will normally be disabled when the external VCO is used, see section 7.8 for further details.

GCR b2: RF PLL Enable

0: RF PLL disabled, 1: RF PLL enabled.

GCR b1: Rx Mixer Enable

0: Rx Mixer disabled, 1: Rx Mixer enabled

GCR:b0: Tx Mixer Enable

0: Tx Mixer disabled, 1: Tx Mixer enabled

8.2.2 GCR_RD - \$C1

8-bit Read

This register reads the value in register \$31, see section 8.2.1 for details of bit functions.

8.3 Rx Control Register**8.3.1 RX_CON - \$32**

16-bit Write.

Reset value: \$0000

This register controls operational modes of the receiver, such as gain setting.

All bits of this register are cleared to '0' by a General Reset command.

15	14	13	12	11	10	9	8	7	6	5	4	3	2	1	0
IR INV	Reserved				IF Mode	Reserved			VG		VL		IR	Div	

RX_CON: b15 – Image reject control

Image reject control. With b15 = '0' the Rx mixer should be used with low-side LO; with b15 = '1' it should be used with high-side LO.

RX_CON: b14-b11

Reserved set to '0'.

RX_CON: b10 – IF Mode

IF Mode – Intermediate Frequency Select

0: 112.5MHz

1: 225MHz

RX_CON: b9-b7

Reserved set to '0'.

RX_CON: b6-b5 – VG Control

Variable Gain (VG) Control; these bits control the gain of the Rx mixer, reducing the gain from the maximum in 6dB steps.

b6	b5	VG
1	1	-18dB
1	0	-12dB
0	1	-6dB
0	0	0dB (Maximum gain)

RX_CON: b4-b3 – VL Control

Variable Gain (VL) Control: these bits control the gain of the LNA stage, reducing the gain from the maximum in 6dB steps.

b4	b3	VL
1	1	-18dB
1	0	-12dB
0	1	-6dB
0	0	0dB (Maximum gain)

RX_CON: b2 – Image Reject

Image reject (IR) control. With b2 = '0' the Rx mixer operates in normal mode; with b2 = '1' the Rx mixer operates in image reject mode.

RX_CON: b1-b0 – Rx Divider

These bits select the Rx Divider (Div):

b1	b0	Div
0	0	Divide by 1 (this mode should not be selected if mixer is used in image reject mode)
0	1	Divide by 2
1	0	Divide by 4
1	1	Reserved – do not use

8.3.2 RX_CON_RD - \$C2

16-bit read

This register reads the value in \$32, see section 8.3.1 for details of bit functions.

8.4 Tx Control Register

8.4.1 TX_CON - \$33

8-bit Write

Reset value: \$00

This register controls transmitter features. All bits of this register are cleared to '0' by a General Reset command.

7	6	5	4	3	2	1	0
Gain 1	Gain 0	Reserved		IR_INV	Tx_IR	TxDiv1	TxDiv0

TX_CON b7-b6: Input Gain

Input Gain Control: These bits control the internal gain applied to input signals before they are sent to the Tx mixer.

b7	b6	
0	0	Input gain = 0 dB
0	1	Input gain = -3 dB
1	0	Input gain = -6 dB
1	1	Input gain = 0 dB

TX_CON b5-b4:

Reserved, clear to '0'.

TX_CON b3: sideband rejection control

Sideband rejection control. With b3 = '0' the Tx mixer should be used with low-side LO; with b3 = '1' it should be used with high-side LO.

TX_CON b2: sideband reject enable

Sideband reject enable. With b2 = '0' the Tx mixer operates in normal mode; with b2 = '1' the Tx mixer operates in sideband reject mode.

TX_CON b1-b0 – Tx Divider

These bits select the Tx Divider.

b1	b0	
0	0	Divide by 1 (this mode should not be selected if mixer is used in image reject mode)
0	1	Divide by 2
1	0	Divide by 4
1	1	Reserved – do not use.

8.4.2 TX_CON_RD - \$C3

8-bit Read

This register reads the value in register \$33, see section 8.4.1 for details of bit functions.

8.5 RF PLL**8.5.1 RFPLL_CON - \$34**

16-bit Write
Reset value: \$0000

15	14	13	12	11	10	9	8	7	6	5	4	3	2	1	0
Reserved		Mode select			Enable dither	Res	S	Reserved		En_low power	Invert CP	Charge pump current			

RFPLL_CON b15:

Clear to '0'

RFPLL_CON b14-b11: Mode select

Set these bits as follows:

1100 - Fractional-N divider with 3rd order maximum length MASH 1-1-1 modulator.

1101 - Fractional-N divider with 3rd order maximum length MASH 1-1-1 post-filtered modulator.

1110 - Reserved do not use

1111 - Reserved do not use

RFPLL_CON b10: Enable dither

Set this bit to '1' to add a "dither" to the LSB of the fractional divide value. This helps to suppress idle tones from the sigma-delta modulator output. Set this bit to '0' to disable the dither.

RFPLL_CON b9: Resolution

Set this bit to '0' to select a 24-bit fractional value for the main divider (using registers RFPLL_FDIV1 and RFPLL_FDIV0). Set this bit to '1' to select a 16-bit fractional value for the main divider (using register RFPLL_FDIV0 only).

RFPLL_CON b8: S (Select)

This signal is only used in Duplex mode; set to '1' to connect the PLL/VCO to the Tx Mixer; set to '0' to connect the PLL/VCO to the Rx mix

RFPLL_CON b7-b6

Reserved, Clear to '0'

RFPLL_CON b5: En_lowpower

When set to '1' the RFPLL working range is 700MHz to 3.75GHz. When set to '0' the working range of the RFPLL is 3.75GHz to 6GHz.

RFPLL_CON b4: Invert Charge Pump

When this bit is cleared to '0', the charge pump will sink current when the multi modulus divider output frequency is higher than the reference divider output frequency. Set this bit to '1' to invert the charge pump output, so it sources current when the reference divider output frequency is greater than the multi modulus divider output frequency.

RFPLL_CON b3-b0: Charge pump current

Sets the value of the charge pump output current pulses. The value can be set in increments of 25µA, from 25µA (0000) to 400µA (1111).

8.5.2 RFPLL_BLEED - \$35

8-bit Write
Reset value: \$00

7	6	5	4	3	2	1	0
Reserved		Enable bleed	Bleed_setting				

RFPLL_BLEED b7-b6

Reserved, clear to '0'.

RFPLL_BLEED b5: Enable bleed

Set to '1' to enable a constant bleed current to be sourced into the associated charge pump output pin.

RFPLL_BLEED b4-b0: Bleed current setting

These bits control the nominal bleed current sourced into the charge pump output pin, according to the following formula:

$$I_{bleed} = 3.125 \mu\text{A} \times (1 + \text{Bleed_setting})$$

The bleed current can therefore be set to a value within the range 3.125µA ... 100µA. For example, if RFPLL_BLEED bits 4-0 = 1100₂, the resulting nominal bleed current will be 3.125µA×(1+12) = 40.625µA.

8.5.3 RFPLL_LOCKDET - \$36

16-bit Write

Reset value: \$0000

15	14	13	12	11	10	9	8	7	6	5	4	3	2	1	0
Lock detect enab	reserved	Reset lock	reserved	Lock window			Loss-of-lock threshold			Lock threshold					

RFPLL_LOCKDET b15: Lock detect enable

Set this bit to '1' to enable the lock detector circuit. Set this bit to '0' to disable and powersave the lock detector circuit.

RFPLL_LOCKDET b14

Reserved, clear to '0'.

RFPLL_LOCKDET b13: Reset lock

Writing a '1' to this bit generates a short pulse that resets the lock detector (either analogue or digital) to an out-of-lock condition and clears DEVICE_STATUS Register bit 0. Immediately after writing a '1' to the reset lock bit, it is cleared back to '0' and the lock detector and lock status bits resume normal operation.

RFPLL_LOCKDET b12-b11

Reserved, clear to '0'.

RFPLL_LOCKDET b10-b8: Lock window

While the lock counter is active (i.e. lock = '1'), these bits determine the phase detector error window: if the difference in arrival time of the phase detector inputs is within this window, they are deemed to be "in phase". When sufficient consecutive "in phase" pulses occur (determined by RFPLL_LOCKDET bits 4-0) then the lock signal gets set to '1'. The nominal value of the error window is shown in the following table:

<u>bits 10-8</u>	<u>Lock window</u>	<u>bits 10-8</u>	<u>Lock window</u>
\$0	±7 ns	\$4	±30 ns
\$1	±10 ns	\$5	±50 ns
\$2	±15 ns	\$6	±70 ns
\$3	±20 ns	\$7	±100 ns

RFPLL_LOCKDET b7-b5: Loss-of-lock threshold

While the lock indicator is active (lock = '1'), these bits determine how many consecutive "out of phase" signals must occur at the phase detector before loss-of-lock is detected, causing the lock indicator to go inactive (lock = '0'). The loss-of-lock threshold can be set from 1 to 8 ('000' = 8).

RFPLL_LOCKDET b4-b0: Lock threshold

While the lock indicator is inactive (lock = '0'), these bits determine how many consecutive "in phase" signals must occur at the phase detector before lock is detected, causing the lock indicator to go active (lock = '1'). The lock threshold can be set to between 1 and 32 ('00000' = 32).

8.5.4 RFPLL_FLCK - \$37

16-bit Write

Reset value: \$0000

15	14	13	12	11	10	9	8	7	6	5	4	3	2	1	0
Reserved			Enab fastlock	Fastlock timer coarse divide			Fastlock timer fine divide						Fastlock current		

RFPLL_FLCK b15-b13
Reserved, clear to '0'.

RFPLL_FLCK b12: Enable fastlock

Set to '1' to enable fastlock. Then each time the main divider registers are updated (see section 8.5.8) the associated fastlock pin (FLCK) is pulled to ground, the charge pump current changes to the value set by RFPLL_FLCK bits 1-0, and the fastlock timer is started. The fastlock state continues until the timer expires, at which point the fastlock pin returns to a high impedance state and the charge pump current reverts to the value determined by RFPLL_CON bits 3-0.

RFPLL_FLCK b11-b9: Fastlock timer coarse divide

RFPLL_FLCK b8-b2: Fastlock timer fine divide

These bits control the duration of the fastlock mode. The coarse divide can be set to a value between 0 and 7, and the fine divide can be set to between 1 and 128 ('0000000' = 128). The fastlock timer is clocked by the internal system clock CLK, and its period is given by the following expression:

$$T_{FASTLOCK} = \frac{4^{CoarseDivide} \times FineDivide}{f_{CLK}}$$

RFPLL_FLCK b1-b0: Fastlock current

Set the value of the charge pump output current pulses in fastlock mode. The value is set as a multiple M of the nominal charge pump current:

RFPLL_FLCK_b1-0	Charge pump multiplier
00	4x
01	8x
10	12x
11	16x

To maintain loop stability with fastlock active the resistor R3 shown in Figure 18 will typically need to be set to the following value:

$$R3 \approx \frac{R1}{\sqrt{M} - 1}$$

With fastlock active the PLL lock time is decreased by a factor of approximately \sqrt{M} . In practice, an even greater reduction is often achieved because fastlock can reduce or eliminate "cycle slipping" in the phase detector.

8.5.5 RFPLL_RDIV - \$38

8-bit Write
Reset value: \$00

7	6	5	4	3	2	1	0
Reserved		Reference divider					

RFPLL_RDIV b7
Reserved, clear to '0'.

RFPLL_RDIV b6-b0

Sets the division ratio between the master clock MCLK and the PLL reference clock. This value can be set to between 1 and 128 ('0000000' = 128).

8.5.6 RFPLL_IDIV - \$39

16-bit Write
Reset value: \$0080

15	14	13	12	11	10	9	8	7	6	5	4	3	2	1	0
Reserved					Main divider integer value										

RFPLL_IDIV b15-b11

Reserved, clear to '0'.

RFPLL_IDIV b10-b0: Main divider integer value

These bits represent the integer portion closest to the desired fractional-N divider value. The integer value is combined with the fractional value from registers RFPLL_FDIV1 and RFPLL_FDIV0 (which represent a fractional offset of between approximately +0.5 and -0.5) to allow selection of the desired VCO frequency. The valid range for the main divider integer value is from 32 to 2047 (in integer-N mode). When operating in fractional-N mode, the fractional-N range should be adjusted so that when added to the maximum sigma-delta modulus value, the resulting range should not exceed 32-2047 range. This register may be reconfigured during RFPLL operation.

8.5.7 RFPLL_FDIV0 - \$3A

16-bit Write

Reset value: \$0000

15	14	13	12	11	10	9	8	7	6	5	4	3	2	1	0
Main divider fractional value (LSB)															

See section 8.5.8 for details of bit functions.

8.5.8 RFPLL_FDIV1 - \$3B

8-bit Write

Reset value: \$00

7	6	5	4	3	2	1	0
Main divider fractional value (MSB)							

RFPLL_FDIV0 b15-b0: Main divider fractional value (LSB)**RFPLL_FDIV1 b7-b0: Main divider fractional value (MSB)**

In fractional-N mode, the fractional divide value ranges between approximately -0.5 and +0.5 as determined by the RFPLL_FDIV1 and RFPLL_FDIV0 registers:

With fractional resolution set to 24 bits, the registers are concatenated to form a 24-bit 2's complement number *fdiv*. The resulting fractional divide value is equal to $(fdiv \div 2^{24})$, which is in the range -0.5 to +0.49999994...

With fractional resolution set to 16 bits, the RFPLL_FDIV1 register is ignored and the value in the RFPLL_FDIV0 register is treated as a 16-bit 2's complement number *fdiv*. The fractional divide value is equal to $(fdiv \div 2^{16})$, which is in the range -0.5 to +0.49998474...

In integer-N mode, both the RFPLL_FDIV1 and RFPLL_FDIV0 registers are ignored.

The RFPLL_FDIV1 and RFPLL_FDIV0 registers may be reconfigured during RFPLL operation.

8.5.9 RFPLL_RDIV_RD - \$C8

8-bit Read

7	6	5	4	3	2	1	0
Reserved		Reference divider					

This register reads the value in register \$38, see section 8.5.5 for details of bit functions.

8.5.10 RFPLL_IDIV_RD - \$C9

16-bit Read

15	14	13	12	11	10	9	8	7	6	5	4	3	2	1	0
<i>Reserved</i>					Main divider integer value										

This register reads the value in register \$39, see section 8.5.6 for details of bit functions.

8.5.11 RFPLL_FDIV0_RD - \$CA

16-bit Read

15	14	13	12	11	10	9	8	7	6	5	4	3	2	1	0
Main divider fractional value (LSB)															

This register reads the value in register \$3A, see section 8.5.7 for details of bit functions.

8.5.12 RFPLL_FDIV1_RD - \$CB

8-bit Read:

7	6	5	4	3	2	1	0
Main divider fractional value (MSB)							

This register reads the value in register \$3B, see section 8.5.8 for details of bit functions.

8.6 IF PLL**8.6.1 IFPLL_NDIV - \$3C**

16-bit Write

Reset value: \$0080

15	14	13	12	11	10	9	8	7	6	5	4	3	2	1	0
<i>Reserved</i>				N Divider											

IFPLL_NDIV b15-b14

Reserved, clear to '0'.

IFPLL_NDIV b13-b0

Phase Locked Loop N divider value (must be greater than or equal to 25).

This register sets the N divider value for the PLL (Feedback divider). Note: To enable the PLL, b5 of the General Control Register (\$31) also needs to be set.

8.6.2 IFPLL_RDIV - \$3D

16-bit Write

Reset value: \$0002

15	14	13	12	11	10	9	8	7	6	5	4	3	2	1	0
<i>Reserved</i>								R Divider							

IFPLL_R_DIV b15-b9

Reserved, clear to '0'.

IFPLL_R DIV b8-b0

Phase Locked Loop R divider value (must be greater than or equal to 2).

This register sets the R divider value for the PLL (Reference divider). Register updates can be asynchronous to the IFPLL phase detector clock.

8.6.3 IFPLL_CURRENT - \$3E

8-bit Write
Reset value: \$00

7	6	5	4	3	2	1	0
IF VCO Bias	Reserved			Charge pump current			

IFPLL_CURRENT b7: IF VCO Bias

IF VCO bias control for optimum phase noise performance. When cleared to '0' (default), sets the IF VCO bias current to "low", when set to 1 set bias current to high.
High current should be chosen for IF VCO oscillation frequencies greater than 700MHz.

IFPLL_CURRENT b6-b4

Reserved, clear to '0'.

IFPLL_CURRENT b3-b0: Charge pump current

Sets the value of the charge pump output current pulses. The value can be set in increments of 25µA, from 25µA (0000) to 400µA (1111).

8.6.4 IFPLL_NDIV_RD - \$CC

16-bit Read

15	14	13	12	11	10	9	8	7	6	5	4	3	2	1	0
Reserved						N Divider									

This register reads the value in register \$3C, see section 8.6.1 for details of bit functions.

8.6.5 IFPLL_RDIV_RD - \$CD

16-bit Read

15	14	13	12	11	10	9	8	7	6	5	4	3	2	1	0
Reserved								R Divider							

This register reads the value in register \$3D, see section 8.6.2 for details of bit functions.

8.6.6 IFPLL_CURRENT_RD - \$CE

8-bit Read

7	6	5	4	3	2	1	0
IF VCO Bias	Reserved			Charge pump current			

This register reads the value in register \$3E, see section 8.6.3 for details of bit functions.

8.7 VCO Calibration**8.7.1 VCO_CAL_CTRL - \$50**

16-bit Write
Reset value: \$1400

15	14	13	12	11	10	9	8	7	6	5	4	3	2	1	0
MCLK FREQUENCY SET								Reserved				IFVCO Start	RFVCO Start	Bias Start	

VCO_CAL_CTRL b15-b8

Value set to divide MCLK input clock (MHz rounded to the nearest integer, with a minimum value of 1) to provide a 1MHz clock, used as 1µs timing reference for the VCO Calibration circuits. The default value of the MCLK_FREQ field is 20.

VCO_CAL_CTRL b7-b3

Reserved, clear to '0'.

VCO_CAL_CTRL b2

Writing a '1' to this bit initiates IFVCO frequency calibration.

VCO_CAL_CTRL b1

Writing a '1' to this bit initiates RFVCO frequency calibration.

VCO_CAL_CTRL b0

Writing a '1' to this bit initiates BIAS calibration. The bias calibration should be initiated before frequency calibration.

For further details see section 7.6.5.

8.7.2 VCO_BIAS_CAL_WRITE - \$51

8-bit Write

Reset value: \$00

7	6	5	4	3	2	1	0
Reserved				VCO bias cal setting			

VCO_BIAS_CAL_WRITE b7-b5

Reserved, clear to '0'.

VCO_BIAS_CAL_WRITE b4-b0

VCO bias calibration setting.

For further details see section 7.6.5.

8.7.3 VCO_BIAS_CAL_TIME - \$52

8-bit Write

Reset value: \$06

7	6	5	4	3	2	1	0
Reserved				Bias cal settling period in μ s			

VCO_BIAS_CAL_TIME b7-b6

Reserved, clear to '0'.

VCO_BIAS_CAL_TIME b5-b0Bias calibration settling period in μ s.

The minimum recommended value for VCO_BIAS_CAL_TIME = 6.

For further details see section 7.6.5.

8.7.4 RFVCO_CAL_WRITE - \$53

16-bit Write

Reset value: \$0000

15	14	13	12	11	10	9	8	7	6	5	4	3	2	1	0
Reserved								Calibration Code							

RFVCO_CAL_WRITE b15-b9

Reserved, clear to '0'.

RFVCO_CAL_WRITE b8-b0

Calibration Code.

For further details see section 7.6.5.

8.7.5 RFVCO_CAL_COUNT - \$54

16-bit Write

Reset value: \$015E

15	14	13	12	11	10	9	8	7	6	5	4	3	2	1	0
<i>Reserved</i>						RF VCO open-loop calibration reference clock cycles									

Default RF VCO open-loop calibration reference clock cycles = 350.

The default value assumes a 3500MHz RF VCO operating frequency.

This value should be set to the RF VCO operating frequency in MHz divided by 10.

For further details see section 7.6.5.

8.7.6 RFVCO_CAL_TIME - \$55

16-bit Write

Reset value: \$0D06

15	14	13	12	11	10	9	8	7	6	5	4	3	2	1	0
PLL settling time after closing loop x 8 μ s								Closed-loop calibration settling time x 8 μ s							

Default PLL settling time after closing loop = 104 μ s.Default Closed-loop calibration settling time = 48 μ s.

For further details see section 7.6.5.

8.7.7 RFVCO_STARTUP_TIME - \$56

16-bit Write

Reset value: \$012C

15	14	13	12	11	10	9	8	7	6	5	4	3	2	1	0
<i>Reserved</i>				RFVCO Start-up time in μ s											

Default RF VCO start-up time = 300 μ s.

For further details see section 7.6.5.

8.7.8 IFVCO_CAL_WRITE - \$57

16-bit Write

Reset value: \$0000

15	14	13	12	11	10	9	8	7	6	5	4	3	2	1	0
<i>Reserved</i>							Calibration Code								

For further details see section 7.7.3.

8.7.9 IFVCO_CAL_COUNT - \$58

16-bit Write

Reset value: \$01C2

15	14	13	12	11	10	9	8	7	6	5	4	3	2	1	0
<i>Reserved</i>						IF VCO open-loop calibration reference clock cycles									

Default IF VCO open-loop calibration reference clock cycles = 450.

The default value assumes a 900MHz IF VCO operating frequency.

This value should be set to the IF VCO operating frequency in MHz divided by 2.

For further details see section 7.7.3.

8.7.10 IFVCO_CAL_TIME - \$59

16-bit Write

Reset value: \$0D0D

15	14	13	12	11	10	9	8	7	6	5	4	3	2	1	0
PLL settling time after closing loop x 8 μ s								Closed-loop calibration settling time x 8 μ s							

Default PLL settling time after closing loop = 104 μ s.Default Closed-loop calibration settling time = 104 μ s.

For further details see section 7.7.3.

8.7.11 IFVCO_STARTUP_TIME - \$5A

16-bit Write

Reset value: \$0145

15	14	13	12	11	10	9	8	7	6	5	4	3	2	1	0
Reserved				IFVCO Start-up time in μ s											

Default IF VCO start-up time = 325 μ s. For further details see section 7.7.3.**8.7.12 VCO_BIAS_CAL_READ - \$5B**

8-bit Read

Reset value: \$00

Only valid when VCO_CAL_STAT bit 0 is '0'.

7	6	5	4	3	2	1	0
Reserved				VCO bias cal setting			

This register reads the value in register \$51, see section 8.7.2 for details of bit functions.

8.7.13 RFVCO_CAL_READ - \$5C

16-bit Read

Reset value: \$0000

Only valid when VCO_CAL_STAT bit 1 is '0'.

15	14	13	12	11	10	9	8	7	6	5	4	3	2	1	0
Reserved								Calibration Code							

This register reads the value in register \$53, see section 8.7.4 for details of bit functions.

8.7.14 IFVCO_CAL_READ - \$5D

16-bit Read

Reset value: \$0000

Only valid when VCO_CAL_STAT bit 2 is 0.

15	14	13	12	11	10	9	8	7	6	5	4	3	2	1	0
Reserved								Calibration Code							

This register reads the value in register \$57, see section 8.7.8 for details of bit functions.

8.7.15 VCO_CAL_STAT - \$5E

8-bit Read

Reset value: \$00

7	6	5	4	3	2	1	0
<i>Reserved</i>					IFVCO	RFVCO	BIAS

This register gives status information on calibration initiated in register \$50, see section 8.7.1.

VCO_CAL_STAT b2

Read '0' = Idle, '1' = IF VCO Calibration in progress.

VCO_CAL_STAT b1

Read '0' = Idle, '1' = RF VCO Calibration in progress.

VCO_CAL_STAT b0

Read '0' = Idle, '1' = BIAS Calibration in progress.

8.8 LO Control**8.8.1 LO_CONTROL - \$3F**

8-bit Write

Reset value: \$00

PLL Output Control Mode.

7	6	5	4	3	2	1	0
<i>Reserved</i>		IFPLLDIV		<i>Reserved</i>	LODIV		

LO_CONTROL b7-b6

Reserved, clear to '0'.

LO_CONTROL b5-b4: IFPLLDIV

The IFPLLDIV bits control the output divider, which drives the IFPLL signal onto the IFPLLOUT pin.

b5	b4	Function
0	0	Divide by 1
0	1	Divide by 4
1	0	Divide by 8
1	1	Divide by 16

LO_CONTROL b3

Reserved, clear to '0'.

LO_CONTROL b2-b0: LODIV

The LODIV bits control the LO divider, which is part of the LO output function.

b2	b1	b0	Function
1	1	1	Divide by 8
1	1	0	Illegal value, do not use
1	0	1	Divide by 6
1	0	0	Divide by 4
0	1	1	Illegal value, do not use
0	1	0	Divide by 2
0	0	1	Divide by 1
0	0	0	Divider off

8.8.2 LO_CONTROL_RD - \$CF

8-bit Read

7	6	5	4	3	2	1	0
<i>Reserved</i>		IFPLLDIV		<i>Reserved</i>		LODIV	

This register reads the value in register \$3F, see section 8.8.1 for details of bit functions.

8.9 Device Status Register**8.9.1 DEVICE_STATUS - \$C4**

8-bit Read

7	6	5	4	3	2	1	0
Clock Ready	RF VCO Calibrate HI	RF VCO Calibrate LO	IF VCO Calibrate HI	IF VCO Calibrate LO	IF and RF PLL Lock	IF PLL Lock	RF PLL Lock

If the corresponding bit in the IRQ_ENABLE register (\$C5) is '0', this register bit provides a real-time indication of the status at the time the register is read. See section 8.10.1.

If the corresponding bit in the IRQ_ENABLE register is '1', this register bit is set to '1' when a specific transition in the status is detected and an active low interrupt will be raised on the IRQN pin. The register bit is cleared to '0' on reading the DEVICE_STATUS register.

The DEVICE_STATUS register bits require the PLL reference clock to be active. If neither PLL is enabled, the PLL reference clock will be disabled and the DEVICE_STATUS register bits will be automatically cleared.

DEVICE_STATUS b7: Clock Ready

If the corresponding bit in the IRQ_ENABLE register is '0', this bit will reflect the status of the PLL reference clock:

0 = PLL reference clock is internally disabled or has not yet stabilised after being enabled and functions requiring this clock are prohibited.

1 = PLL reference clock has started successfully.

If the corresponding bit in the IRQ_ENABLE register is '1', the bit will be set to '1' on detecting a positive transition in the Clock Ready status.

DEVICE_STATUS b6: RF VCO Calibration HI

If the corresponding bit in the IRQ_ENABLE register is '0', this bit will reflect the status of the RF VCO Calibration HI voltage comparator output:

0 = RF VCO tune voltage is below the HI voltage threshold.

1 = RF VCO tune voltage is above the HI voltage threshold indicating the RF VCO has drifted too low in frequency and requires recalibration, either by entering a larger calibration code directly or by performing a new auto-calibration routine as outlined in section 7.6.5.1. This bit may change during RF VCO calibration.

If the corresponding bit in the IRQ_ENABLE register is '1', the bit will be set to '1' on detecting a positive transition in the RF VCO Calibration HI status. This bit may change during RF VCO calibration and it is therefore recommended that the corresponding IRQ_ENABLE bit is only set after calibration has completed.

DEVICE_STATUS b5: RF VCO Calibration LO

If the corresponding bit in the IRQ_ENABLE register is '0', this bit will reflect the status of the RF VCO Calibration LO voltage comparator output:

0 = RF VCO tune voltage is above the LO voltage threshold.

1 = RF VCO tune voltage is below the LO voltage threshold indicating the RF VCO has drifted too high in frequency and requires recalibration, either by entering a smaller calibration code directly or by performing a new auto-calibration routine as outlined in section 7.6.5.1. This bit may change during RF VCO calibration.

If the corresponding bit in the IRQ_ENABLE register is '1', the bit will be set to '1' on detecting a positive transition in the RF VCO Calibration LO status.

DEVICE_STATUS b4: IF VCO Calibration HI

If the corresponding bit in the IRQ_ENABLE register is '0', this bit will reflect the status of the IF VCO Calibration HI voltage comparator output:

0 = IF VCO tune voltage is below the HI voltage threshold.

1 = IF VCO tune voltage is above the HI voltage threshold indicating the IF VCO has drifted too low in frequency and requires recalibration, either by entering a larger calibration code directly or by performing a new auto-calibration routine as outlined in section 7.6.5.1. This bit may change during IF VCO calibration.

If the corresponding bit in the IRQ_ENABLE register is '1', the bit will be set to '1' on detecting a positive transition in the IF VCO Calibration HI status. This bit may change during IF VCO calibration and it is therefore recommended that the corresponding IRQ_ENABLE bit is only set after calibration has completed.

DEVICE_STATUS b3: IF VCO Calibration LO

If the corresponding bit in the IRQ_ENABLE register is '0', this bit will reflect the status of the IF VCO Calibration LO voltage comparator output:

0 = IF VCO tune voltage is above the LO voltage threshold.

1 = IF VCO tune voltage is below the LO voltage threshold indicating the IF VCO has drifted too high in frequency and requires recalibration, either by entering a smaller calibration code directly or by performing a new auto-calibration routine as outlined in section 7.6.5.1. This bit may change during IF VCO calibration.

If the corresponding bit in the IRQ_ENABLE register is '1', the bit will be set to '1' on detecting a positive transition in the IF VCO Calibration LO status. This bit may change during IF VCO calibration and it is therefore recommended that the corresponding IRQ_ENABLE bit is only set after calibration has completed.

DEVICE_STATUS b2: IF and RF PLL Lock

If the corresponding bit in the IRQ_ENABLE register is '0', this bit reflects the PLLs lock status:

0 = IF PLL and RF PLL are not both locked.

1 = IF PLL and RF PLL are both locked.

If the corresponding bit in the IRQ_ENABLE register is '1', this bit will be set to '1' on detecting a negative transition in either PLL lock status. This indicates that either PLL has lost lock. Note, this is the opposite sense to the status indication.

DEVICE_STATUS b1: IF PLL Lock

If the corresponding bit in the IRQ_ENABLE register is '0', this bit reflects the IF PLL lock status:

0 = IF PLL is not locked.

1 = IF PLL is locked.

If the corresponding bit in the IRQ_ENABLE register is '1', this bit will be set to '1' on detecting a negative transition in the IF PLL lock status. This indicates the IF PLL has lost lock. Note, this is the opposite sense to the status indication.

DEVICE_STATUS b0: RF PLL Lock

If the corresponding bit in the IRQ_ENABLE register is '0', this bit reflects the RF PLL lock status:

0 = RF PLL is not locked.

1 = RF PLL is locked.

If the corresponding bit in the IRQ_ENABLE register is '1', this bit will be set to '1' on detecting a negative transition in the RF PLL lock status. This indicates the RF PLL has lost lock. Note, this is the opposite sense to the status indication.

8.10 Interrupt Enable Register

8.10.1 IRQ_ENABLE - \$C5

8-bit Write

Reset value: \$80

7	6	5	4	3	2	1	0
Clock Ready Interrupt Enable	RF VCO Comp HI Interrupt Enable	RF VCO Comp LO Interrupt Enable	IF VCO Comp HI Interrupt Enable	IF VCO Comp LO Interrupt Enable	IF & RF PLL Lock Interrupt Enable	IF PLL Lock Interrupt Enable	RF PLL Lock Interrupt Enable

IRQ Enable Register b7-b0 : Interrupt enables for DEVICE_STATUS bits

If the enable bit is '0', the corresponding bit in the DEVICE_STATUS register provides a real-time indication of the status at the time the register is read. If the enable bit is '1', the corresponding bit in the DEVICE_STATUS register is set to '1' when a specific event is detected and an active low interrupt will be raised on the IRQN pin. The register bit is cleared to '0' on reading the DEVICE_STATUS register.

8.11 Power Status Register

8.11.1 POWER_STATUS - \$C6

8-bit Read

7	6	5	4	3	2	1	0
<i>Reserved</i>				Digital Ready	RF Functions Ready	IF PLL Ready	RF PLL Ready

Power Status Register b7-b4

Reserved, clear to '0'.

Power Status Register b3-b0

When the respective bit is set to '1', the relevant power domain and bandgap is at its working level. There is a 15µs of delay between enabling an analogue block and the supplies being available for use.

9 Application Notes

9.1 Typical Transceiver Configuration

The CMX975 provides up and down mixing for superhet transmitters / receivers operating in the range 1 GHz to 2.7 GHz and also provides a receiver LNA and fractional-N PLL with integrated VCO. The CMX973 is an ideal partner for the CMX975, the combination providing a complete RF transceiver solution, a typical system block diagram is shown in Figure 25.

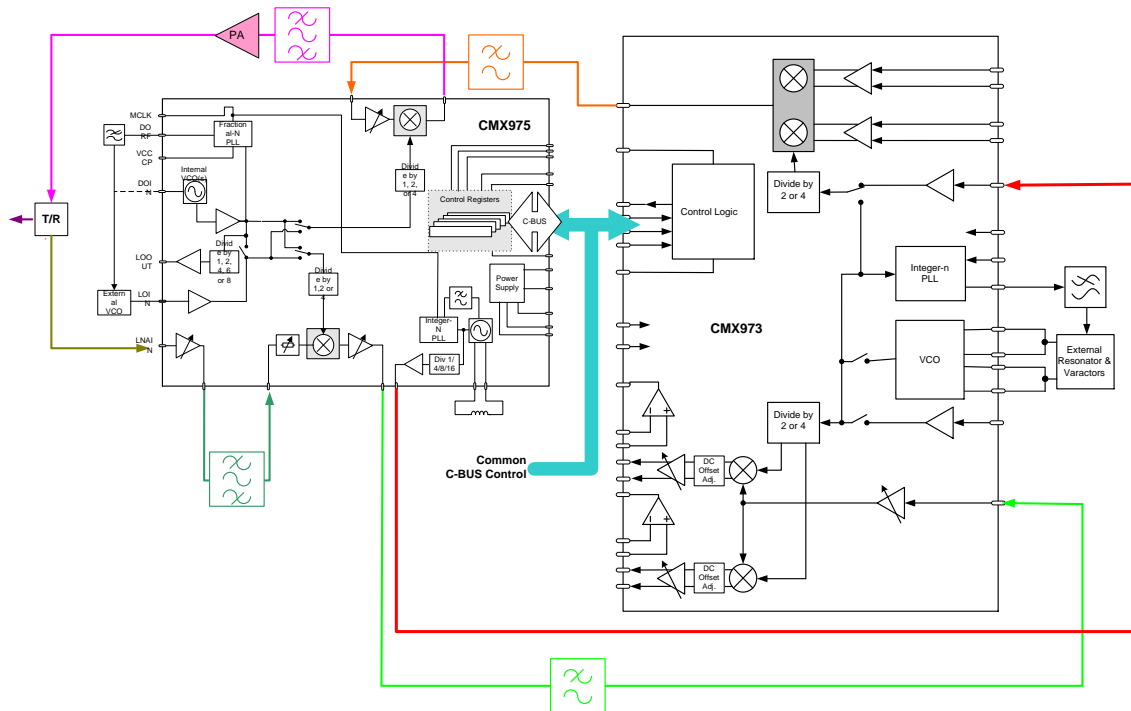

Figure 25 Typical Application Configuration

Considering Figure 25, the transmit path consists of a differential I/Q input to an RF vector modulator (CMX973); the RF modulated output can be anywhere in the range 30MHz to 500MHz (or 200 to 250 MHz if the SSB mode is used in the CMX975 Tx mixer). The output of the CMX973 will typically be passed through a simple LC lowpass filter, to remove harmonics, before being passed to the CMX975 TX mixer input. After up-conversion the mixer output will be filtered to remove mixing products, then amplified to the final Tx output power level.

The Tx LO configuration uses the CMX975 RF PLL for the main up-conversion and the CMX975 IF LO output connected to the CMX973 TXLO input. A typical Tx IF of say 225 MHz could use the CMX975 IF LO at 900 MHz with divide by 4 in the CMX973 (this solution is likely to give the best I/Q modulator phase and amplitude balance).

The receiver path consists of a LNA (CMX975) which would typically be followed by a bandpass filter to provide rejection of out of band interferers. The down-conversion process will result in an IF in the range 20 to 300 MHz (or 200 to 250 MHz if the image reject mode is used in the CMX975 Rx mixer). The IF output will usually pass through a IF channel filter to protect the rest of the receiver from interferers generating intermodulation responses. The IF channel filter would typically be a SAW filter of the appropriate bandwidth. The IF signal would be converted to I/Q format (CMX973) but maybe offset from dc in the case of Near Zero IF (NZIF) or low IF receivers. The differential I/Q output maybe used directly or maybe converted to a single ended by the differential amplifiers provided on the CMX973.

The Rx LO configuration would typically use the CMX973 IF PLL to give an independent choice of IF although the CMX975 IF PLL could be shared with the Tx path in some circumstances (Note: the CMX973 PLL should not be used for the Tx path). The CMX975 RF PLL should be used for the Rx main mixer (shared with the Tx). Note that the Tx and Rx IF frequencies can be chosen independently and this can be used to simplify sharing of the main CMX975 RF PLL between Tx and Rx paths.

9.2 Loop Filter Design

The design of the loop filter for phase locked loops is relatively simple in principle but can be complex in practice. It is impossible in a datasheet to cover all aspects of loop filter design; for those interested in the detail please consult one of the many text books on phase locked loops. This datasheet provides some specific guidance for the CMX975 PLL design.

9.2.1 RF PLL (Fractional N)

The Loop Filter design is based upon the use of a passive 3rd order Loop Filter as shown below.

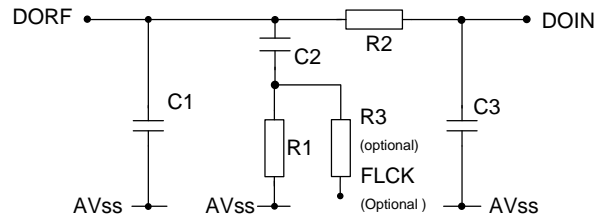

The loop filter can be considered as two pole filter (R1, C1, C2) with the addition of a single pole spur filter (R2,C3) added to attenuate spurs.

The two pole loop filter consists of a resistor R1 in series with a capacitor C2 and C1. The resistor provides the stabilizing zero to improve the phase margin and hence improve the transient response of the PLL. However, the resistor causes a ripple of value $I_{cp} \times R1$ on the control voltage at the beginning of each phase detector pulse. At the end of the pulse, a ripple of equal value occurs in the opposite direction. This ripple modulates the VCO frequency and introduces excessive jitter in the output. A small capacitor C1 is added in parallel with the R1 and C2 network to suppress the glitch generated by the charge pump at every phase comparison instant, which in turn lowers the ripple on the control voltage the ripple and acts to suppress the induced jitter.

C1 should remain below C2 roughly by a factor of 10 so as to avoid underdamped settling. The choice of the loop parameters, R1, C2 and C1 can be determined by assuming a continuous time approximation. In a typical application the loop bandwidth, is set to between $F_{comp}/25$ and $F_{comp}/100$. This value is a compromise as a lower loop bandwidth helps to filter out reference or integer boundary spurs in the PLL output, but a higher loop bandwidth decreases lock time and helps reduce PLL jitter by filtering out noise (esp. flicker noise) within the loop bandwidth.

The frequency at which the PLL open loop phase margin is a maximum, should coincide with the chosen loop bandwidth. The resistor R1, in combination with C1 & C2 capacitors in the two pole loop filter, determines the frequency where the peak phase margin is achieved.

The important loop equations for the two pole filter are as follows:

- (1) $C2 = I_{cp} K_{vco} / N (2\pi F_n)^2$
- (2) $R1 = 2\xi V / (I_{cp} K_{vco} C2)$
- (3) $C1 = C2/10$
- (4) $BW = \pi F_n [\xi + (1/4 \xi)]$
- (5) $\omega_n = 2\pi F_n$
- (6) $PM \sim 100\xi$

where

Fref is the reference clock applied to the ICr
 F_{comp} is the phase detector comparison frequency (= Fref / N)
 N is feedback divider value
 I_{cp} is charge pump current (A/2 π rad)
 K_{vco} is vco gain (MHz/V)
 F_n is the natural loop frequency
 BW is the loop bandwidth
 PM is the phase margin
 ξ is the damping factor

Now looking at the single pole spur filter R2 and C3, the attenuation and time constant T3 can be defined as:

- (7) $Atten = 10 \log [(2\pi F_{comp} R2C3)^2 + 1]$ and

$$(8) \quad T3 = R2C3.$$

Then in terms of the attenuation of the comparison frequency spurs added by the single pole filter we have:

$$(9) \quad T3 = \sqrt{[(10^{(Atten/10)} - 1)/(2\pi F_{Comp})]^2}$$

The additional pole must be lower than the comparison frequency F_{Comp} in order to attenuate spurs, but should be at least 5 times greater than the loop bandwidth, otherwise the loop may become unstable.

In general $C3$ should be chosen to be $\leq C1/10$ otherwise $T3$ will interact with the poles primary two pole filter, $R2$ should be chosen to be at least twice the value of $R1$.

Worked example:

VCO frequency = 3GHz, $F_{Comp} = 4.8\text{MHz}$, $I_{cp} = 400\mu\text{A}$, $K_{VCO} = 70\text{MHz/V}$, $BW = 48\text{kHz}$ ($F_{Comp}/100$), $F_n = 14\text{kHz}$, $Atten=13\text{dB}$, $\xi = 0.707$

- a) $N = 3e09 / 4.8e06 = 625$
- b) $C2 = 5.78\text{nF}$
- c) $R1 = 2.78\text{k}\Omega$
- d) $C1 = 579\text{pF}$
- e) $T3 = 1.57e-07$
- f) Let $R2 = 2R1$, = $5.6\text{k}\Omega$
- g) $C3 = T3/R2 = 28\text{pF}$

The choice should now be made of preferred values for $R1$, $R2$, $C1$, $C2$ and $C3$ using $\pm 1\%$ on resistors and $\pm 5\%$ on capacitors, which would be $C1 = 680\text{pF}$, $C2 = 5.6\text{nF}$, $C3 = 27\text{pF}$, $R1 = 2.2\text{k}\Omega$, $R2 = 5.6\text{k}\Omega$.

The preferred values chosen should then be tested in the application and adjustment can then be made to optimise the loop response as required.

9.3 Phase Noise Performance

9.3.1 RF PLL

The RF PLL typical phase noise profiles are shown in Figure 26, Figure 27 and Figure 28. The effect of the divider is demonstrated in Figure 27.

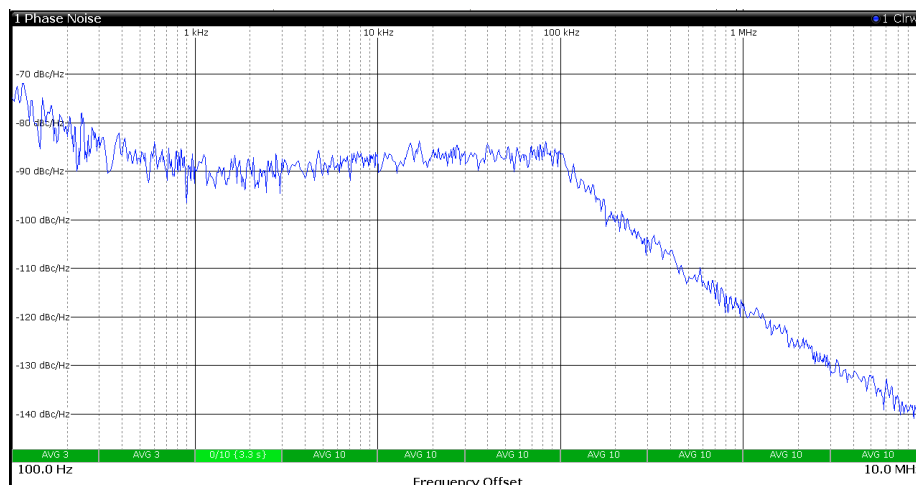

Figure 26 Phase noise plot of 3.6GHz RF PLL, $I_{cp}=400\mu\text{A}$, $F_{Comp}=38.4\text{MHz}$, using internal VCO, 60kHz loop bandwidth, PLL type '1100'

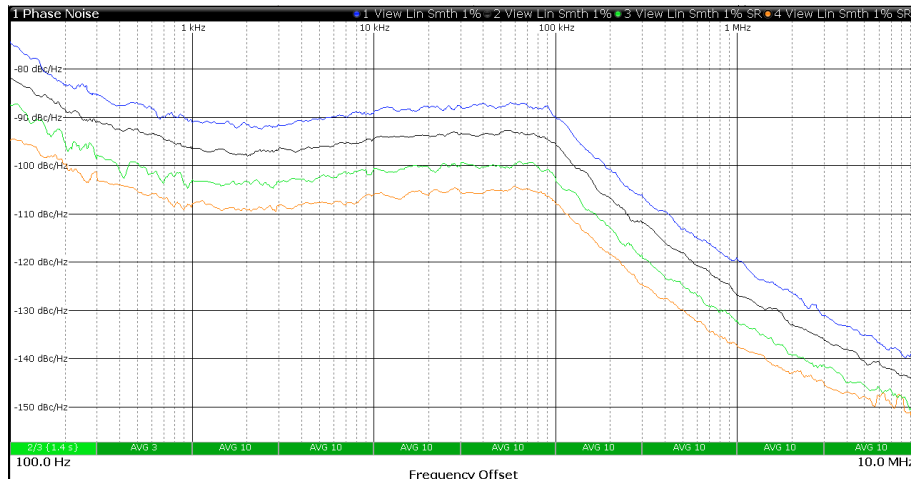

Figure 27 Phase noise plot of 3.201GHz RF PLL, $I_{cp}=400\mu A$, $F_{Comp}=38.4MHz$, using internal VCO, 60kHz loop bandwidth, PLL type '1100' also showing output in /2 mode (1600MHz), /4 mode (800MHz) and /8 mode (400MHz)

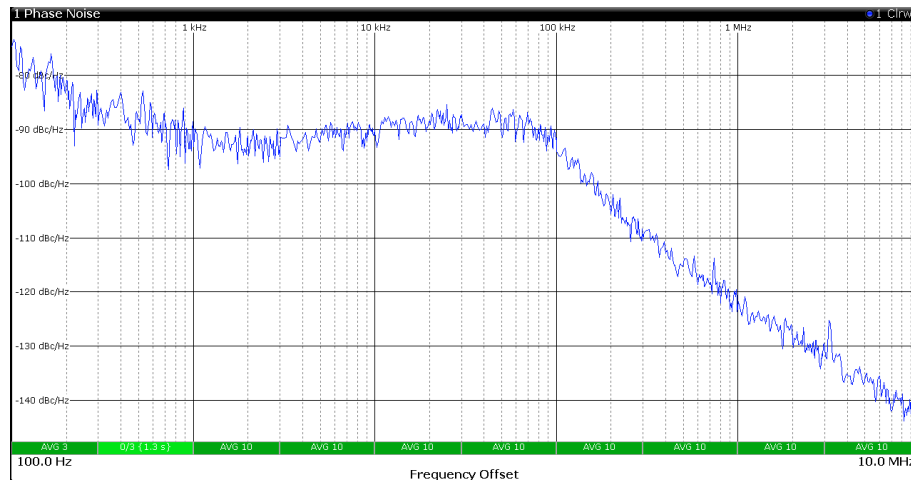

Figure 28 Phase noise plot of 2.8GHz RF PLL, $I_{cp}=400\mu A$, $F_{Comp}=38.4MHz$, using internal VCO, 60kHz loop bandwidth, PLL type '1100'

Figure 29, Figure 30 and Figure 31 using the 19.2MHz Golledge MP05955 are shown in the following diagrams.

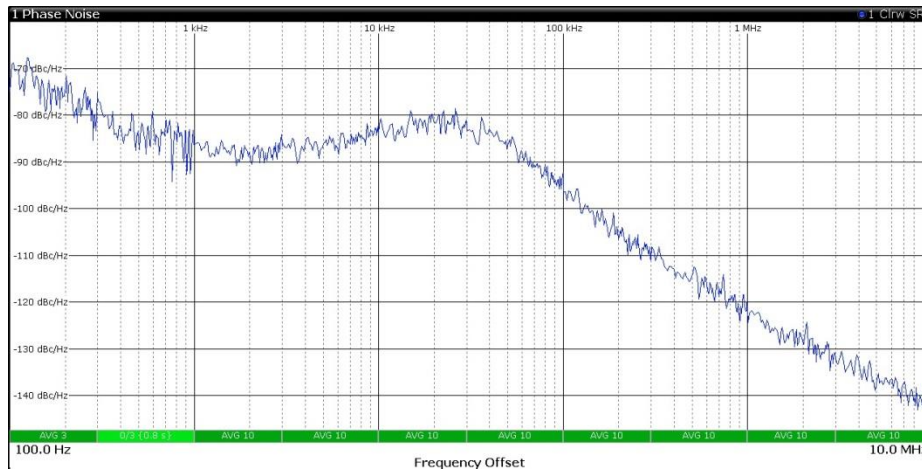

Figure 29 Phase noise plot of 2.8GHz RF PLL, $I_{cp}=400\mu A$, $F_{Comp}=19.2MHz$, using internal VCO, PLL type '1100'

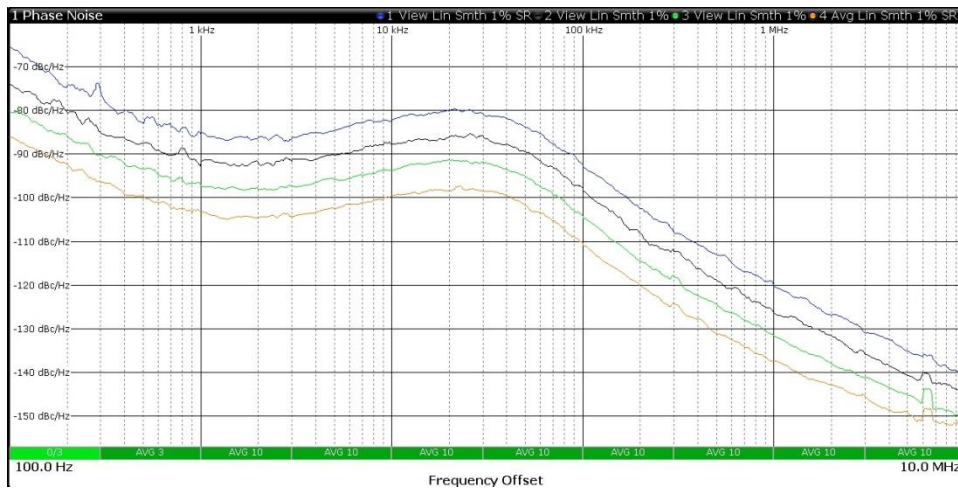

Figure 30 Phase noise plot of 3.2GHz RF PLL, $I_{cp}=400\mu A$, $F_{Comp} = 19.2MHz$, using internal VCO, 60kHz loop bandwidth, PLL type '1100' also showing output in /2 mode (1600MHz), /4 mode (800MHz) and /8 mode (400MHz)

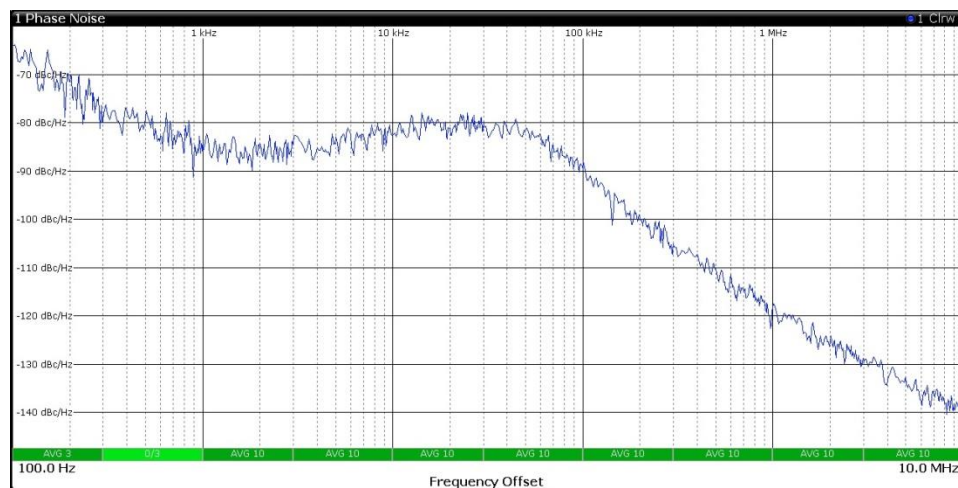

Figure 31 Phase noise plot of 3.6GHz RF PLL, $I_{cp}=400\mu A$, $F_{Comp} = 19.2MHz$, using internal VCO, PLL type '1100'

9.3.2 IF PLL Phase Noise

The IF PLL has a typical phase noise profile as shown in Figure 32 for 900MHz using the internal IF_VCO.

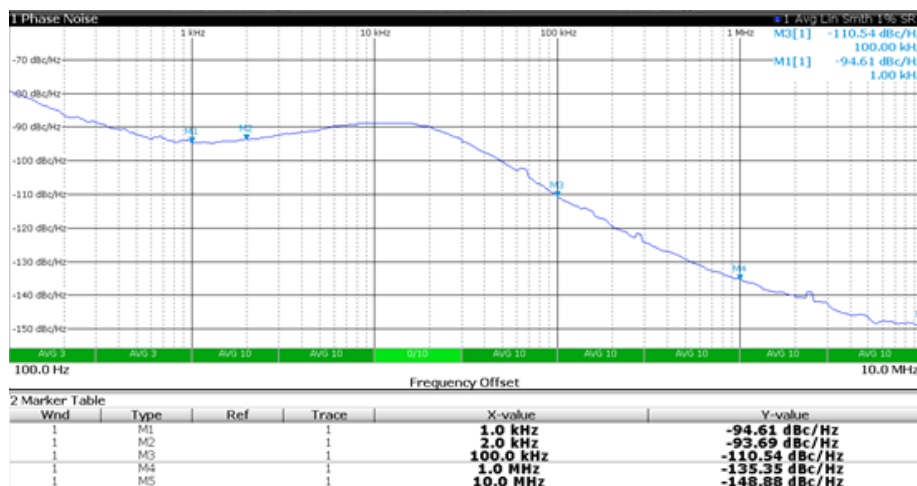

Figure 32 Phase noise plot of 900MHz IF PLL, $I_{cp}=400\mu A$, $F_{Comp} = 1.2MHz$, $K_{vco}=10MHz/V$

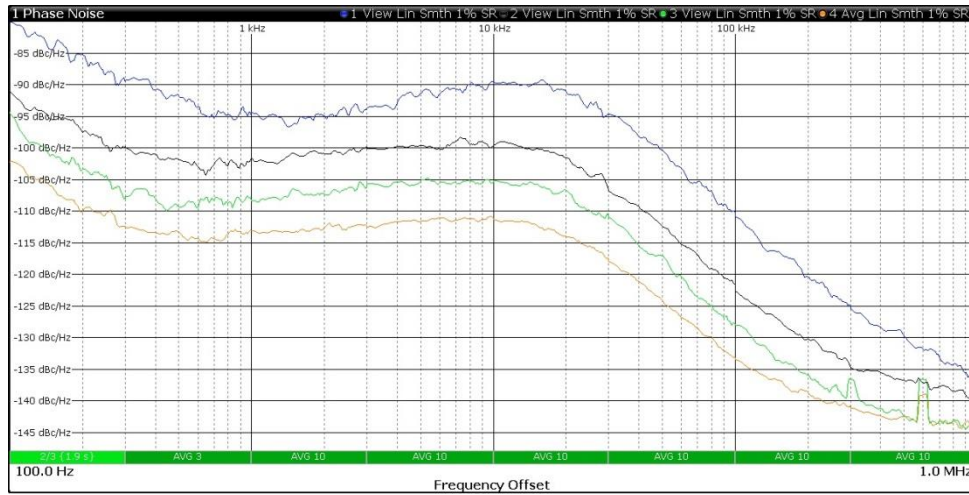

Figure 33 Phase noise plot of 900 MHz IF PLL, $I_{cp} = 400\mu A$, $F_{Comp} = 1.2MHz$, also showing the effects of selecting the /4 (225 MHz), /8 (112.5MHz) and /16 (56.25 MHz) outputs

9.4 RF PLL Lock Time

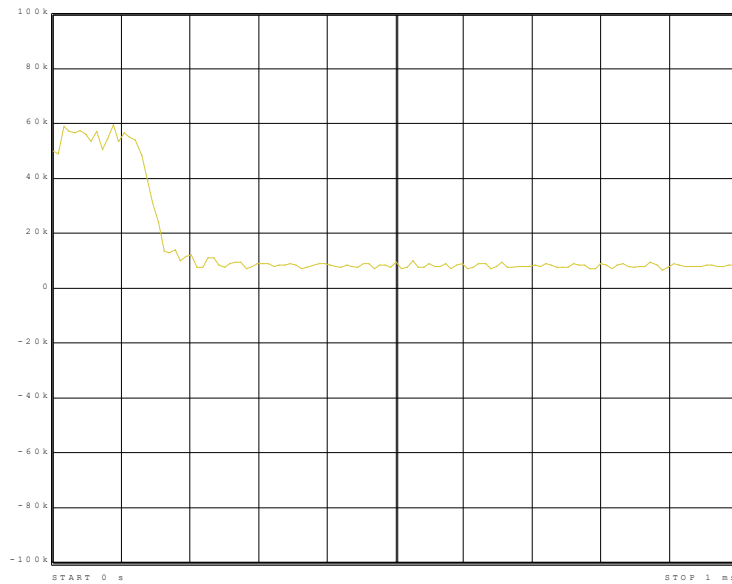

Figure 34 Lock time for frequency change 2.850GHz to 3.450GHz, $I_{cp}=400\mu A$, $F_{Comp}=19.2MHz$, using internal VCO , 60 kHz loop bandwidth, PLL type '1100', without Fastlock function, Jump =300 μs

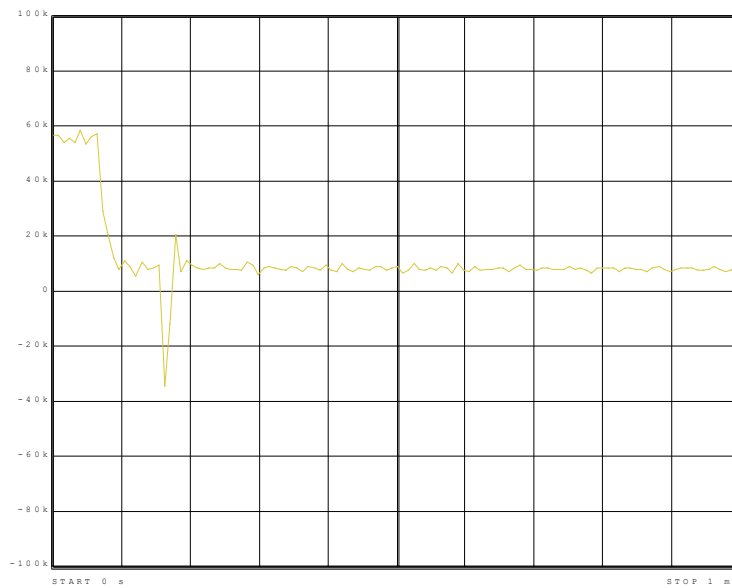

Figure 35 Lock time for frequency change 2.850GHz to 3.450GHz, $I_{cp}=400\mu A$, $F_{Comp}=19.2MHz$, using internal VCO , 60kHz loop bandwidth, PLL type '1100', with Fastlock function (x12, 100 μs), Jump =200 μs

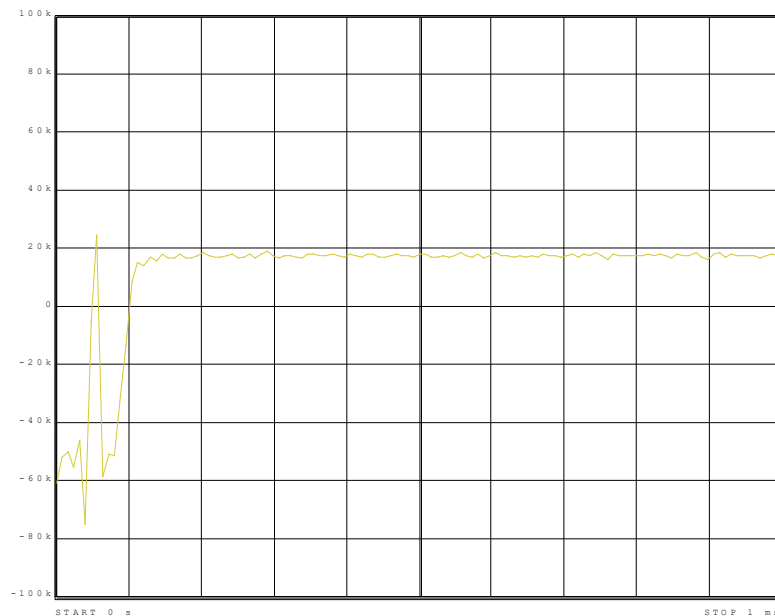

Figure 36 Lock time for frequency change 3.205 to 3.195GHz, $I_{cp}=400\mu A$, $F_{Comp}=19.2MHz$, using internal VCO , 60kHz loop bandwidth, PLL type '1100', without Fastlock function, Jump = 150 μs

9.5 RF PLL Spurious

9.5.1 Types of Spurious

Spurious signals (spurs for short) from a Fractional-N PLL can occur at offsets from the main output of:

- The input Master reference frequency (sidebands at \pm MCLK and harmonics)
- The loop comparison frequency (sidebands at \pm F_{Comp} , i.e. \pm MCLK/RDIV and harmonics)
- Frequencies offset from the integer-N frequency (e.g. at $N \times F_{Comp}$, also referred to as 'Integer Boundary Spurs' or 'IBS'). These can be reduced by the action of the loop filter.
- Frequencies offset from simple fractions of the integer-N frequency (also referred to as 'high order boundary spurs'). These can be reduced by the action of the loop filter.

Frequency planning for the particular application, along with avoidance techniques, can be used to minimise some of these effects.

The spurs can also be reduced in level through use of the output frequency dividers (although other spurs can also be generated).

All of the above spur types can be observed in the CMX975.

9.5.2 MCLK Sidebands

Sidebands can occur at offsets of the input reference frequency (sidebands at \pm MCLK and harmonics). PCB Layout, decoupling, MCLK frequency and signal level, harmonic content and on-chip coupling can all have an effect on these levels. Fast MCLK edges are required for the lowest noise performance, but this can be at the detriment of spur level.

9.5.3 Comparison Frequency Sidebands

Sidebands can occur at offsets of the Comparison Frequency (sidebands at \pm F_{Comp} and harmonics). These spurs are largely reduced by the action of the loop filter.

If $F_{Comp} = MCLK$, the resulting spur levels may be higher than for the MCLK or F_{Comp} spur alone.

9.5.4 MCLK Boundaries

Spurs occur where F_{VCO} is close to $N \times MCLK$, so a large MCLK frequency creates the lowest number of MCLK boundaries. For a given application, a frequency plan should avoid these where possible. A solution is to use two non-harmonically related MCLK sources and switch between them as appropriate.

9.5.5 FComp Boundaries

Spurs occur where F_{VCO} is close to $N \times F_{Comp}$.

Mathematically, these spurs occur at frequencies of +/- the fractional component of N from the VCO frequency. If these are at a sufficiently large offset, then they are reduced by the action of the loop filter. A software routine can be used to determine if the fraction is sufficiently small to cause a problem (i.e. not be sufficiently attenuated by the loop filter).

One solution is to use two different RDIV values (e.g. divide by 4 or 5) and switch between them as appropriate.

If this is coupled with switching MCLK reference sources, many spurious can be avoided.

9.5.6 Higher Order Boundaries

These spurs occur at offsets from simple fractions. For example, if a frequency is programmed at say 10kHz from a 0.5 fraction, spurs can occur at +/- 20kHz and +/- 40kHz (i.e. at harmonics of 20kHz); if 10kHz from a 0.3333 fraction, spurs can occur at approximately +/- 30kHz; if a frequency is programmed at 10kHz from a 0.25 fraction, spurs occur at +/- 40kHz.

The amplitude of these reduce with order and offset from the 'simple fraction'. In practice, a fraction of 1/3 cannot be exactly determined digitally, so there will then be a strong fractional component at +/- (offset + FComp / (2^N)) where N is the number of fractional bits.

Frequency planning can predict where these occur, so again a different RDIV value could be used to avoid these. At small offsets from a 'simple fraction', these can land within the loop bandwidth.

Boundary spurious can also be reduced by applying a small value of bleed current (see section 8.5.2), however this will increase the level of the comparison frequency spurs.

9.6 IF PLL Spurious

The IF PLL has spurious products that occur at multiples of the MCLK reference frequency.

As an example, if a 19.2MHz MCLK is used, with IFPLL_RDIV = 0x0A (10 decimal) and IFPLL_NDIV = 0x01D5 (468 decimal), this gives a programmed VCO frequency of 900.48MHz.

A fixed spur will occur at 47 x MCLK (902.4MHz). In this instance, this will also coincide with a comparison frequency spur (+/- 1.92MHz) at typically -69 dBc.

If the programming is changed to IFPLL_NDIV = 0x01D4 (467 decimal), this gives a programmed VCO frequency of 898.56MHz. The comparison frequency spurs (+/- 1.92MHz) are typically -86 dBc, however a spur will still be present at 902.4MHz (and its image about the carrier) at around -76 dBc.

The spur continues to reduce with increasing separation from odd multiples of MCLK. The spur also occurs around even multiples, but at a lower level. This spur is independent of charge pump current setting.

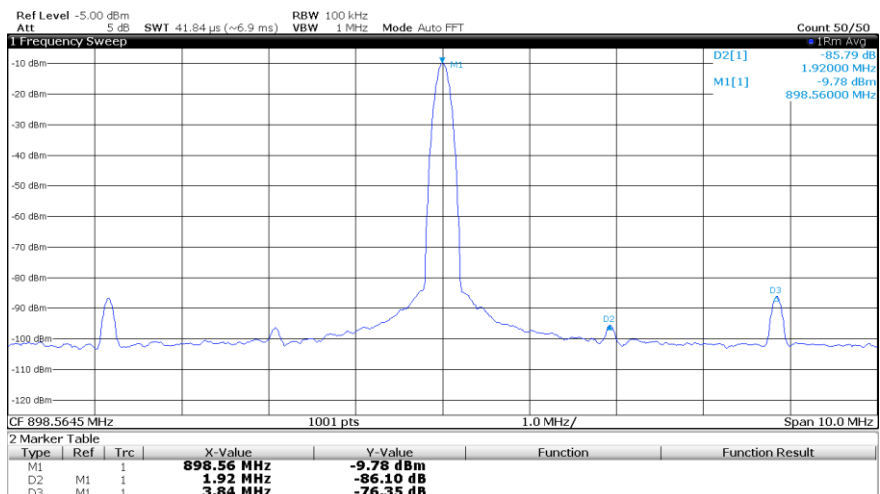

Figure 37 Reference spur plot of 900MHz IF PLL

10 Packaging

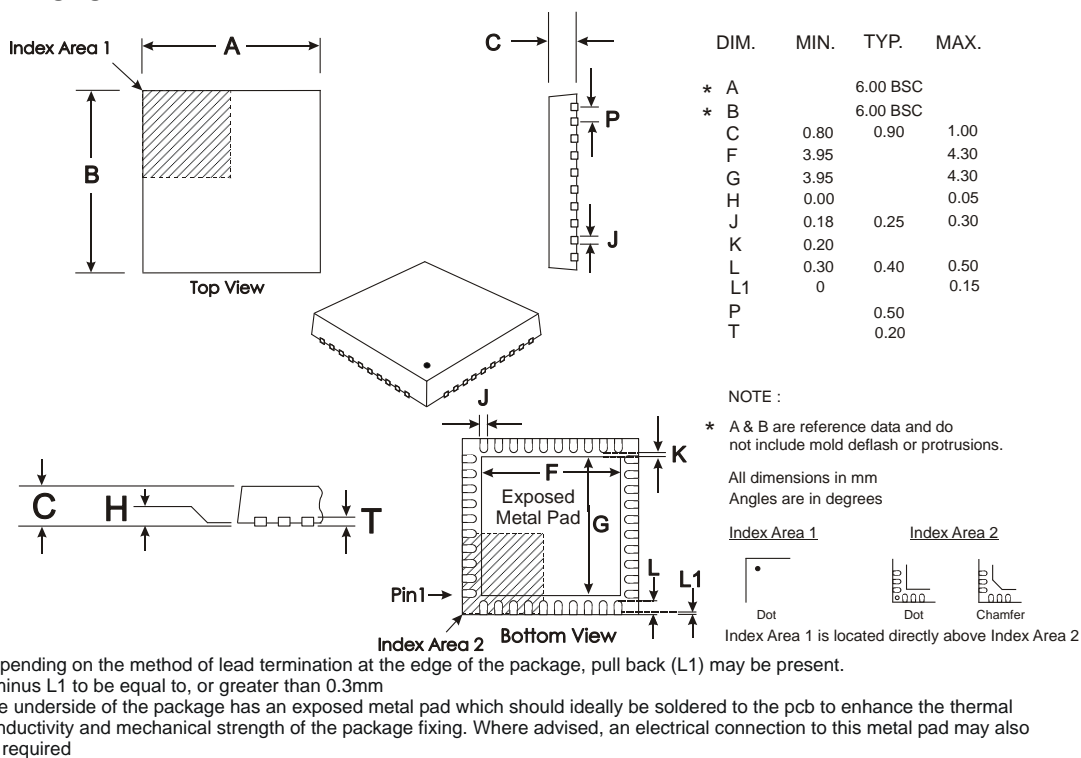

Figure 38 Q4 Mechanical Outline

10.1 Ordering Information

Order as Part No. CMX975Q4

Handling precautions: This product includes input protection, however, precautions should be taken to prevent device damage from electro-static discharge. CML does not assume any responsibility for the use of any circuitry described. No IPR or circuit patent licences are implied. CML reserves the right at any time without notice to change the said circuitry and this product specification. CML has a policy of testing every product shipped using calibrated test equipment to ensure compliance with this product specification. Specific testing of all circuit parameters is not necessarily performed.



United Kingdom	p: +44 (0) 1621 875500	e: sales@cmlmicro.com techsupport@cmlmicro.com
Singapore	p: +65 62888129	e: sg.sales@cmlmicro.com sg.techsupport@cmlmicro.com
United States	p: +1 336 744 5050 800 638 5577	e: us.sales@cmlmicro.com us.techsupport@cmlmicro.com

www.cmlmicro.com

Mouser Electronics

Authorized Distributor

Click to View Pricing, Inventory, Delivery & Lifecycle Information:

[CML Microcircuits:](#)

[CMX975Q4](#) [CMX975Q4-REEL](#)