



CMX972 Quadrature Demodulator with IF PLL/VCO

D/972/3 April 2019

Provisional Issue

Features

- 20 – 300MHz IF/RF Demodulator
- 10MHz Rx I/Q Bandwidth
- < 1 degree I/Q Phase Matching
- < 0.5 dB I/Q Gain Matching
- Low Power, 3.0V – 3.6V Operation
- Small 32-lead VQFN Package

Applications

- Wireless Data Terminals
- HF/VHF and UHF Mobile Radio
- Avionics Radio Systems
- Software Defined Radio (SDR)
- Satellite Terminals

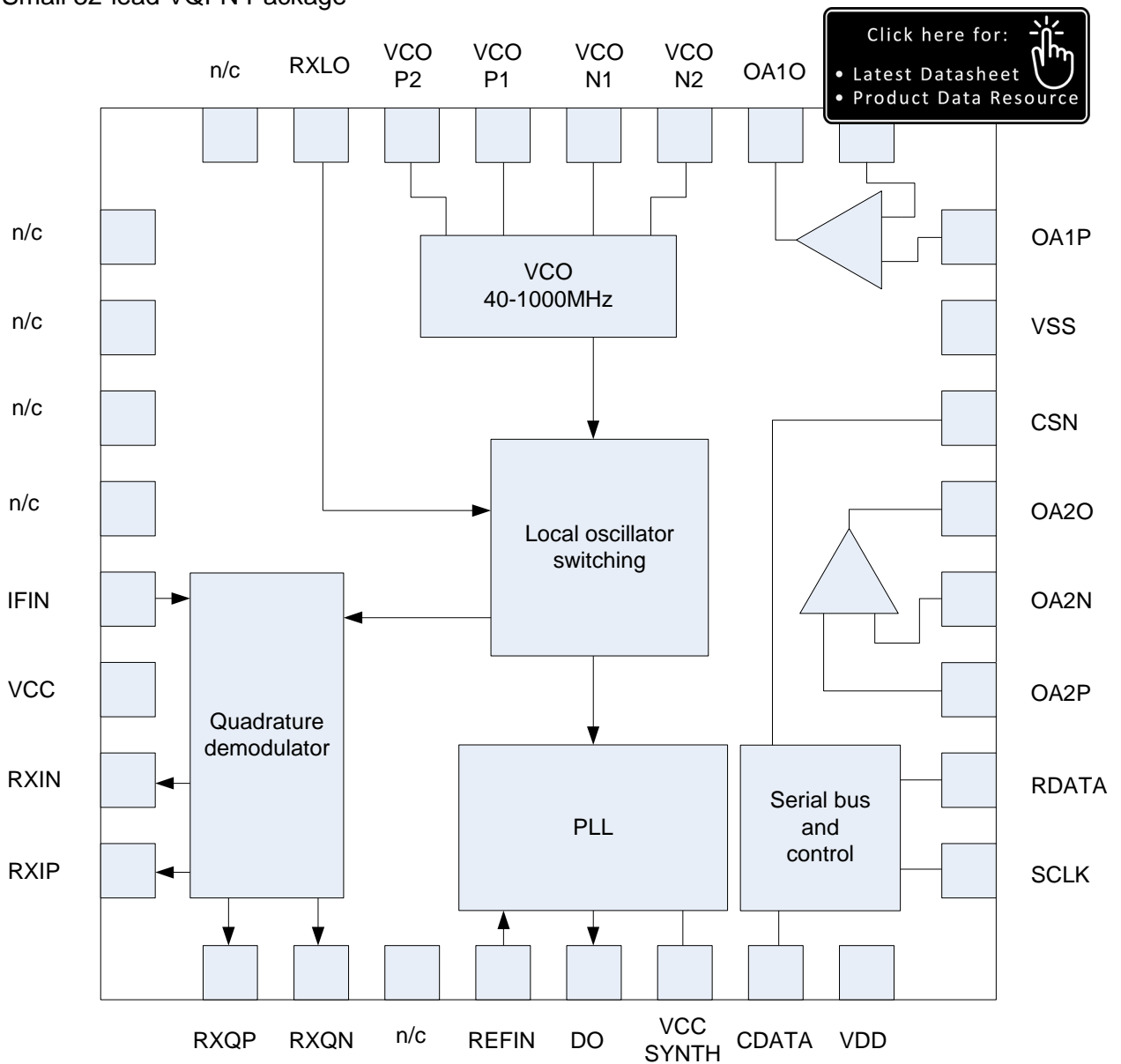

Click here for:

- Latest Datasheet
- Product Data Resource

1 Brief Description

The CMX972 features a low-power quadrature IF/RF demodulator with wide operating frequency range and optimised power consumption. The demodulator is suitable for superheterodyne architectures with IF frequencies up to 300MHz and the device may be used in low IF systems or in those converting down to baseband. An on-chip PLL and VCO, together with uncommitted baseband differential amplifiers, provide additional flexibility. Control of the CMX972 is by serial bus. The CMX972 is supplied in an RF-optimised 32-lead VQFN package.

CONTENTS

<u>Section</u>	<u>Page</u>
1	Brief Description 2
1.1	History..... 5
2	Block Diagram 5
3	Pin List 6
4	External Components 7
4.1	Power Supply Decoupling 7
4.2	Quadrature Demodulator 8
4.3	Local Oscillator (LO) Input 8
4.4	VCO and PLL 8
4.5	Differential Amplifiers 11
4.5.1	I/Q Output Amplifiers 11
4.5.2	Low IF Output 12
5	General Description 13
5.1	Quadrature Demodulator 13
5.1.1	I/Q Amplitude and Phase Correction 13
5.1.2	DC Offset Correction 15
5.2	Differential Amplifiers 16
5.3	Local Oscillator (LO) 16
5.3.1	Demodulator LO Input 16
5.3.2	VCO and PLL 16
6	C-BUS Interface and Register Description 19
6.1	General Reset Command 20
6.1.1	General Reset Command - \$1A: no data 20
6.2	General Control Register 21
6.2.1	General Control Register - \$1B: 8-bit write 21
6.2.2	General Control Register - \$EB: 8-bit read 21
6.3	Rx Control Register 21
6.3.1	Rx Control Register - \$1C: 8-bit write 21
6.3.2	Rx Control Register - \$EC: 8-bit read 22
6.4	Rx Mode Register 22
6.4.1	Rx Mode Register - \$1D: 8-bit write 22
6.4.2	Rx Mode Register - \$ED: 8-bit read 23
6.5	Rx Offset Register 23
6.5.1	Rx Offset Register - \$1F: 8-bit write 23
6.5.2	Rx Offset Register - \$EF: 8-bit read 24
6.6	PLL M Divider Register 24
6.6.1	PLL M Divider - \$2C - \$2A: 8-bit write 24
6.6.2	PLL M Divider - \$DC - \$DA: 8-bit read 25
6.7	PLL R Divider Register 25
6.7.1	PLL R Divider - \$2E - \$2D: 8-bit write 25
6.7.2	PLL R Divider - \$DE - \$DD: 8-bit read 25
6.8	VCO Control Register 25
6.8.1	VCO Control Register - \$2F: 8-bit write 25
6.8.2	VCO Control Register - \$DF: 8-bit read 26
7	Application Notes 27
7.1	IF/RF Input Matching 27
7.2	Demodulator Intermodulation and Output Drive Capability 28

7.3	Variation with Temperature	28
7.4	Effect of Gain Control on Receiver Performance	29
7.5	Measurement of CMX972 Demodulator Intermodulation Performance	31
7.6	Operation with large input signals	32
7.7	VCO Phase Noise.....	33
8	Performance Specification	34
8.1	Electrical Performance.....	34
8.1.1	Absolute Maximum Ratings	34
8.1.2	Operating Limits	34
8.1.3	Operating Characteristics.....	35
8.2	Packaging	40

<u>Section</u>	<u>Page</u>
Table 1 Pin List.....	6
Table 2 Power Supply Component Values	7
Table 3 Quadrature Demodulator Input Components.....	8
Table 4 Internal VCO Amplifier Tank Circuit for 180MHz Operation	10
Table 5 3 rd Order Loop Filter Circuit for 180MHz Operation	10
Table 6 Rx I/Q Differential to Single-ended Amplifier Components.....	11
Table 7 Rx Low IF (455kHz) Components	12
Table 8 Typical Phase Balance, LO/2 Mode.....	14
Table 9 Recommended FREQ bit Settings in the Rx Mode Register	14
Table 10 Effect of FREQ bits (\$1D, b3-b0) on I/Q Phase Balance at 250MHz	15
Table 11 Effect of FREQ bits (\$1D, b3-b0) on I/Q Phase Balance at 300MHz with Temperature	15
Table 12 DC Offset Correction Adjustments	15
Table 13 LO Connections	16
Table 14 PLL Control	18
Table 15 Quadrature Demodulator Input Impedances and Parallel Equivalent Circuit ...	27
Table 16 Typical Noise Figure and Gain of IF Amp, VGA and I/Q Mixer.....	28
Table 17 Typical Third Order Intercept Performance of demodulator at 45MHz (straight-in case)	28
Table 18 Effect of VCONR bits, $f_{vco} = 180$ MHz, divide-by-2	33

<u>Section</u>	<u>Page</u>
Figure 1 Block Diagram.....	5
Figure 2 Power Supply Connections and Decoupling.....	7
Figure 3 IF Input Match Circuit.....	8
Figure 4 RXLO Input Configuration.....	8
Figure 5 Example External Components – VCO External Tank Circuit.....	9
Figure 6 Example External Components – PLL Loop Filter.....	10
Figure 7 Example External Components – Receive I/Q Output	11
Figure 8 Example External Components – Receive Low IF Output	12
Figure 9 Demodulator Gain Control	13
Figure 10 Frequency Response, showing effect of COR bit (\$1C, b6) and FREQ bits(\$1D, b3-b0)	14
Figure 11 Simplified Schematic DC Offset Correction Circuit.....	15
Figure 12 PLL Architecture	17
Figure 13 C-BUS Transactions	20
Figure 14 Quadrature Demodulator Input Impedance (10MHz to 300MHz).....	27
Figure 15 Demodulator Gain Variation With Temperature	29
Figure 16 Variation in Gain with Temperature (COR = '0' \$1D = 0x00)	29
Figure 17 Variation in CMX972 Demodulator Noise Figure with VGA/VGB Control	30
Figure 18 Variation in Input Third Order Intercept Point with VGA/VGB Control.....	30

Figure 19 Variations in Signal and IMD Product Levels 31
 Figure 20 Output Signal Level Variations with Large Input Signals 32
 Figure 21 Effect of VCO Gain on Phase Noise 33
 Figure 22 C-BUS Timing 39
 Figure 23 Q5 Mechanical Outline: *Order as part no. CMX972Q5* 40

1.1 History

Version	Changes	Date
3	• Adjustment of current consumption values (no change in overall performance)	23/4/19
2	• Corrected VCO range to 40 – 1000MHz and changed varactor diode to Toshiba 1SV305	17/2/15
1	• Original document, first approved.	7/12/12

2 Block Diagram

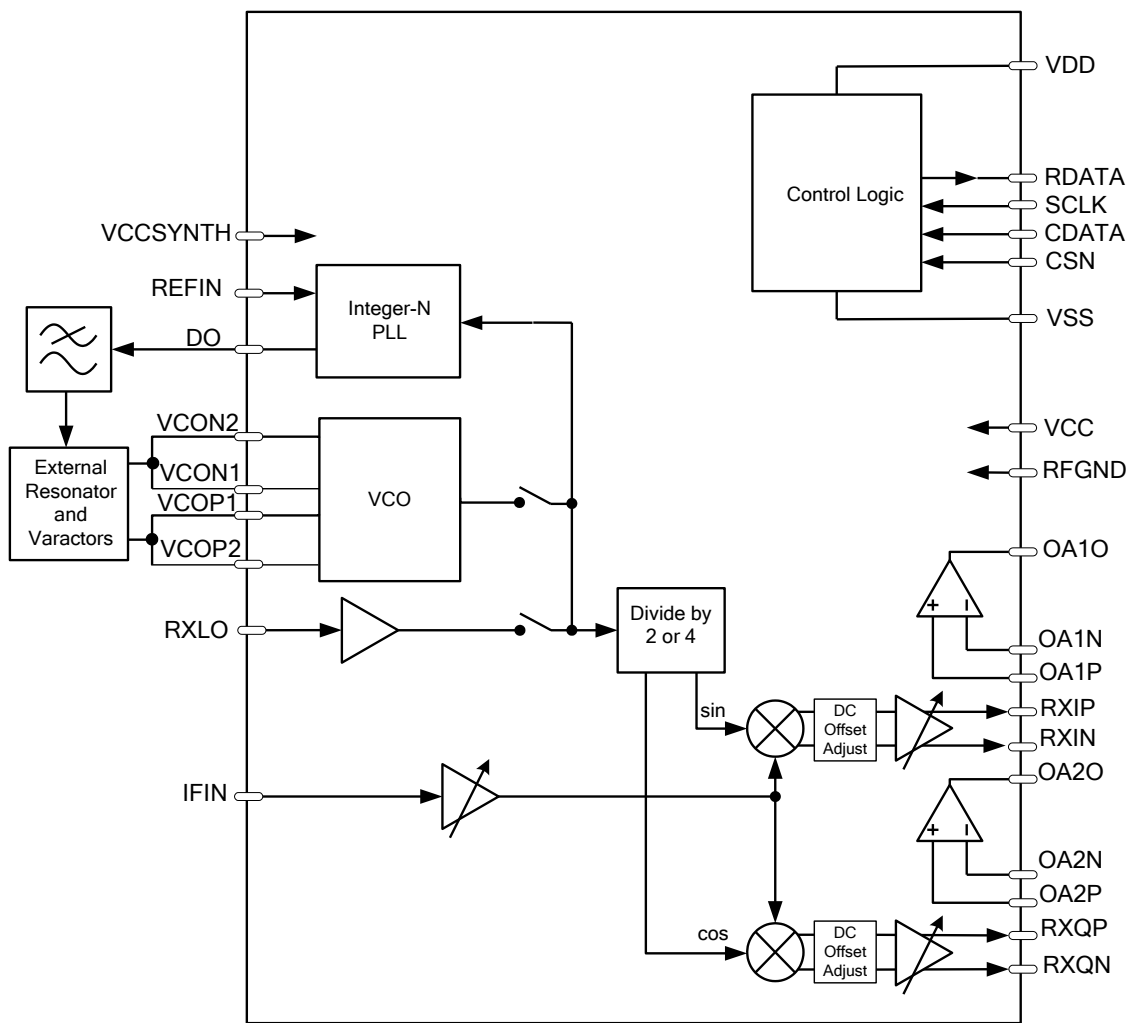

Figure 1 Block Diagram

3 Pin List

Pin	Name	Type	Function
1	~	~	Do not connect to this pin
2	~	~	Do not connect to this pin
3	~	~	Do not connect to this pin
4	~	~	Do not connect to this pin
5	IFIN	IP	IF/RF input signal
6	VCC	PWR	Analogue and RF supply
7	RXIN	OP	Analogue output for baseband receive I signal (negative)
8	RXIP	OP	Analogue output for baseband receive I signal (positive)
9	RXQP	OP	Analogue output for baseband receive Q signal (positive)
10	RXQN	OP	Analogue output for baseband receive Q signal (negative)
11	~	~	Do not connect to this pin
12	REFIN	IP	PLL frequency reference input
13	DO	OP	PLL charge pump output
14	VCCSYNTH	PWR	RF supply for synthesiser
15	CDATA	IP	C-BUS data input
16	VDD	PWR	C-BUS and digital supply
17	SCLK	IP	C-BUS clock input
18	RDATA	TSOP	C-BUS data output
19	OA2P	IP	Baseband amplifier 2 positive input
20	OA2N	IP	Baseband amplifier 2 negative input
21	OA2O	OP	Baseband amplifier 2 output
22	CSN	IP	C-BUS chip select
23	VSS	PWR	C-BUS and digital ground
24	OA1P	IP	Baseband amplifier 1 positive input
25	OA1N	IP	Baseband amplifier 1 negative input
26	OA1O	OP	Baseband amplifier 1 output
27	VCON2	NR	VCO negative port 2
28	VCON1	NR	VCO negative port 1
29	VCOP1	NR	VCO positive port 1
30	VCOP2	NR	VCO positive port 2
31	RXLO	IP	Input for demodulator local oscillator
32	~	~	Do not connect to this pin
33*	RFGND	PWR	Analogue and RF ground

Notes: IP = Input
 OP = Output
 TSOP = Three-state output
 PWR = Power connection
 NR = Negative resistance VCO port

* Pin 33 is the exposed metal pad on the back of the package and should be connected to the RF Ground Plane (V_{RFGND}).

Table 1 Pin List

4 External Components

4.1 Power Supply Decoupling

This device has separate supply pins for the analogue and digital circuitry; a 3.3V nominal supply is recommended.

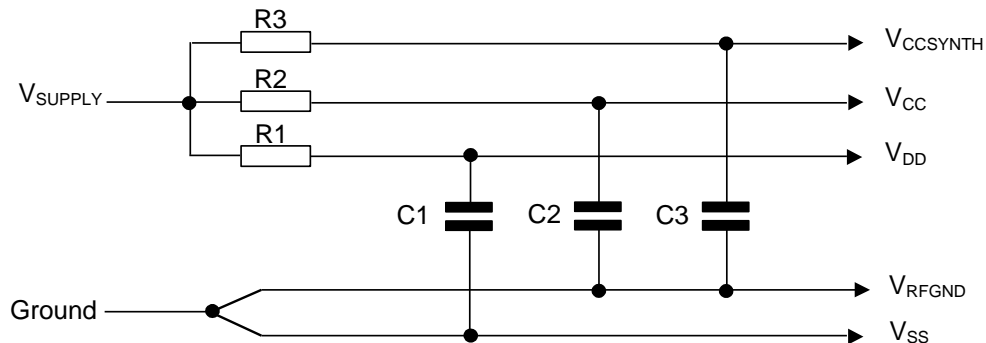

Figure 2 Power Supply Connections and Decoupling

C1	10nF	R1	10 Ω
C2	10nF	R2	3.3 Ω
C3	10nF	R3	10 Ω

Resistors $\pm 1\%$, capacitors $\pm 20\%$

Table 2 Power Supply Component Values

Note:

It is expected that low-frequency interference on the 3.3V supply will be removed by active regulation. A large capacitor is an alternative but may require more board space and so may not be preferred. The supply decoupling shown is intended for RF noise suppression. It is necessary to have a small series impedance prior to the decoupling capacitor for the decoupling to work well. This may be achieved cost effectively by using the resistor as shown. The use of resistors results in small dc voltage drops. Choosing resistor values approximately inversely proportional to the dc current requirements of each supply pin ensures the dc voltage drop on each supply is reasonably matched. In any case, the dc voltage change that results are well within the design tolerance of the device. If higher impedance resistors are used then greater care will be needed to ensure that the supply voltages are maintained within tolerance, including when parts of the device are enabled or disabled.

4.2 Quadrature Demodulator

The input impedance of the quadrature demodulator section is shown in section 7.1. The input can be driven from a 50 Ohm source or can be matched to 50 Ohms. A typical 50 Ohm matching circuit is shown in Figure 3 for operation at 45MHz.

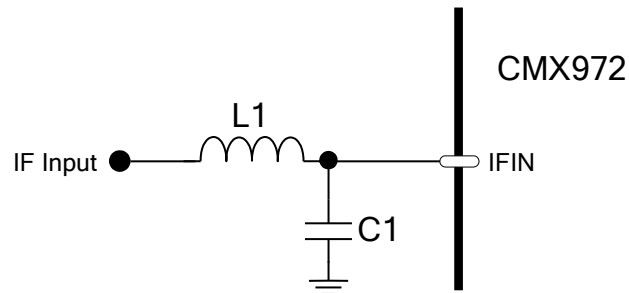

Figure 3 IF Input Match Circuit

L1	910nH
C1	10pF

Table 3 Quadrature Demodulator Input Components

4.3 Local Oscillator (LO) Input

The CMX972 has a single-ended LO input. The demodulator LO can come from either the on-chip VCO/PLL or from an external source (RXLO pin), see section 5.3.

Users should be aware that the presence of high levels of harmonics in the signals applied to the RXLO input might degrade quadrature accuracy.

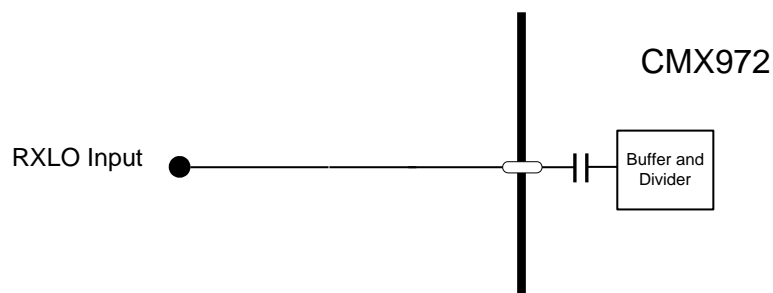

Figure 4 RXLO Input Configuration

4.4 VCO and PLL

A typical configuration for using the internal VCO negative resistance amplifier at 180MHz is shown in Figure 5. The other external components required to complete the PLL are the loop filter components, see Figure 6 – which shows a 3rd order loop filter; typical values for a 300Hz bandwidth are given in Table 5.

VCOP1 should be connected to VCOP2 and similarly VCON1 to VCON2 in order to form the negative resistance loop. It is recommended that the parallel LC tank (L1/C1) is situated as close to the package as possible, with the inductor closest to the device pins. Also the shorting of VCOP1 to VCOP2 and of VCON1 to VCON2 occurs as close as possible to the tank circuit – this minimises the effects of series inductance on the oscillator behaviour.

For further information see also section 7.7.

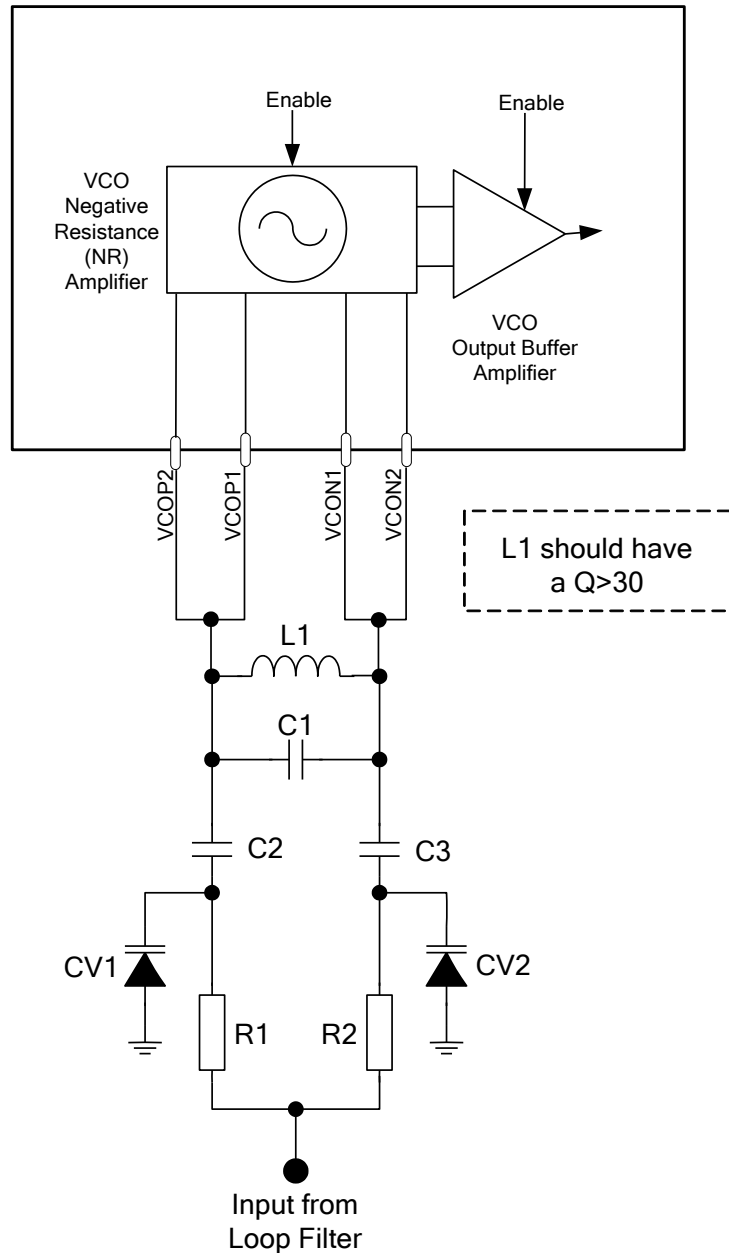

Figure 5 Example External Components – VCO External Tank Circuit

L1	51nH (Note 1)	CV1	SMV1705-079LF
C1	8.2pF (Note 2)	CV2	SMV1705-079LF
C2	27pF	R1	10kΩ
C3	27pF	R2	10kΩ

Note 1: Tolerance of 2% or better recommended
 Note 2: Tolerance of 5% or better recommended

Table 4 Internal VCO Amplifier Tank Circuit for 180MHz Operation

Alternative diodes may be used for CV1, CV2, for example the Toshiba 1SV305 (for which no other value changes should be necessary). For increased tuning range the Skyworks SMV1249-079LF can be used: in this case changing the tank circuit values is recommended. For operation at 180MHz, make L1 = 56nH and C1=6.8pF, then C2 and C3 can be adjusted to give the desired tuning range: with C2, C3 = 27pF the VCO gain (K_v) = 15 MHz/V and with C2, C3 = 12pF, K_v = 8MHz/V. For C2, C3 = 12pF, the value of C1 should be changed to 8.2pF, to give a control voltage closer to the centre of the tuning range.

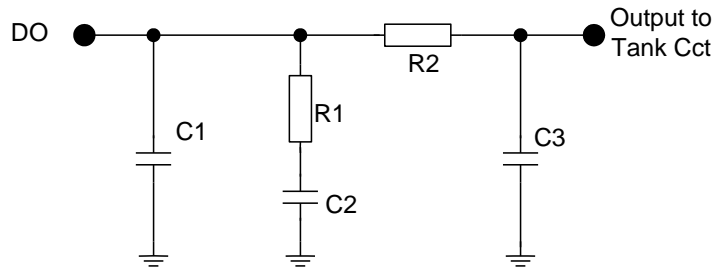

Figure 6 Example External Components – PLL Loop Filter

C1	150nF	R1	1.5kΩ
C2	1μF	R2	2.4kΩ
C3	15nF		

Table 5 3rd Order Loop Filter Circuit for 180MHz Operation

4.5 Differential Amplifiers

The CMX972 provides two uncommitted differential amplifiers which may be used for a range of purposes. Two possible configurations are shown in the following sections, however other uses include buffering or level shifting of the modulator I/Q signals.

4.5.1 I/Q Output Amplifiers

The uncommitted differential amplifiers may be used to convert the differential I/Q output signals to a single-ended output. A typical configuration of the amplifier on the Q channel (the I channel is identical) is shown in Figure 7. This circuit has a linear gain of 1.5. Although the circuit is not optimum for rejection of common mode signals, in practice performance is generally still satisfactory if R4 is omitted (i.e. replaced with a 0 Ohm link). Users should note that the gain and bandwidth of this stage can be adjusted by altering the component values and should be configured to suit a particular application.

C1 and C2 may be fitted to provide filtering if required.

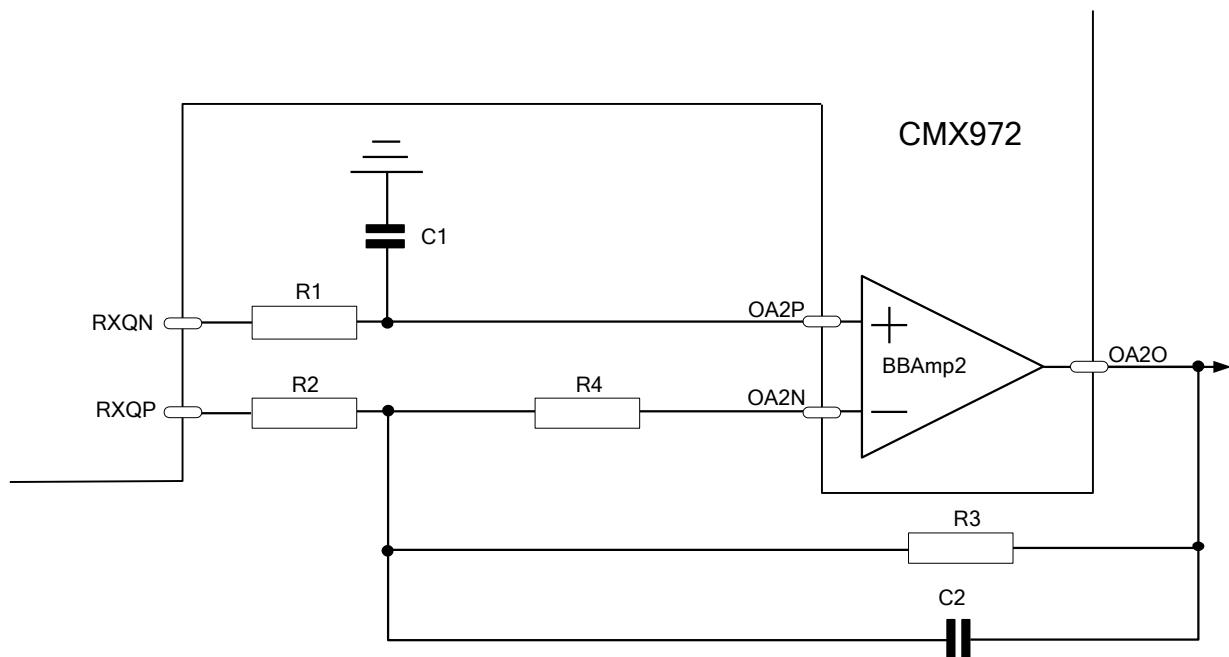

Figure 7 Example External Components – Receive I/Q Output

C1	NF	R2	10kΩ
C2	NF	R3	10kΩ
R1	10kΩ	R4	5kΩ Note 1

Note 1: The value of R4 should be calculated from the value of the other resistors using the calculation $R4 = R1 - ((R2 * R3) / (R2 + R3))$.

Table 6 Rx I/Q Differential to Single-ended Amplifier Components

4.5.2 Low IF Output

The quadrature demodulator output bandwidth is at least 5MHz, (see section 8.1.3.3), so the output of each quadrature demodulator mixer can be configured to mix down to a low IF and use one of the differential amplifiers to provide gain. A possible configuration for the Q channel is shown in Figure 8.

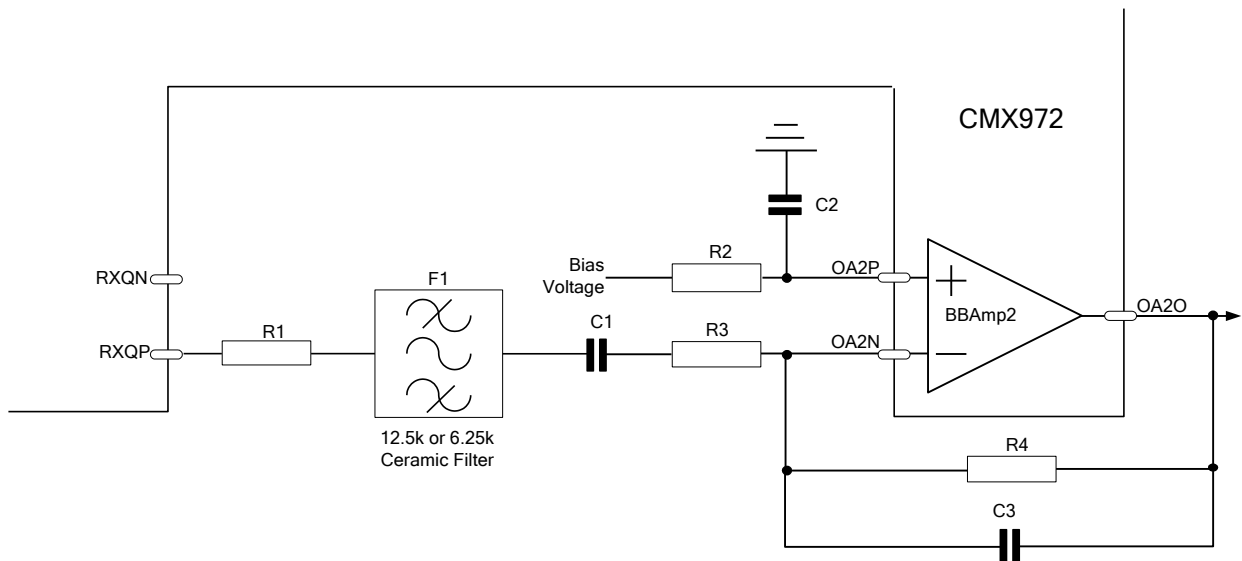

Figure 8 Example External Components – Receive Low IF Output

C1	100nF	R1	1.5kΩ
C2	47nF	R2	1.5kΩ
C3	33pF	R3	1.5kΩ
F1	CFWL455KEFA-B0	R4	4.7kΩ

Table 7 Rx Low IF (455kHz) Components

The components above specify, as an example, a particular ceramic filter (F1) that would typically be used in a 25kHz channel application in a system with an IF frequency of 455kHz. The other component values specified (e.g. R1, R3) are determined by the input/output impedance of the filter used. The filter and other components can be easily changed to allow for other bandwidths and IF frequencies.

A different external IF filter, e.g. of different bandwidth, could similarly be connected to the I channel output to support a second modulation bandwidth mode, e.g. to receive a 6.25kHz channel signal. The channel to be used is selectable via the Rx Mode register (\$1D), section 6.4.1, the unused channel being powered-down.

5 General Description

The CMX972 is an RF integrated circuit providing a quadrature demodulator, integer-N synthesiser and an IF VCO. Additional features include gain control and uncommitted differential amplifiers. A detailed block diagram for the IC is shown in section 2. The device can support a wide range of modulation formats and standards. The following sections describe the functionality of the CMX972.

5.1 Quadrature Demodulator

The quadrature demodulator is designed for IF/RF operation, having very low power consumption. Input frequencies in the range 20MHz to 300MHz are allowed. The demodulator system has two gain-controlled stages, one before and one after the I/Q down-converters, as shown in Figure 9. The two gain control elements can be independently controlled (see section 6.3.1). This adjustability allows users to optimise characteristics depending on their system requirements. Minimum noise figure can be maintained by decreasing gain in VGA with VGB at maximum gain. Intermodulation performance can be optimised by decreasing gain in VGA or VGB. A lower gain in VGA will tend to reduce dc offsets in the output I/Q signal. For further information on the effects of control of VGA and VGB see section 7.4.

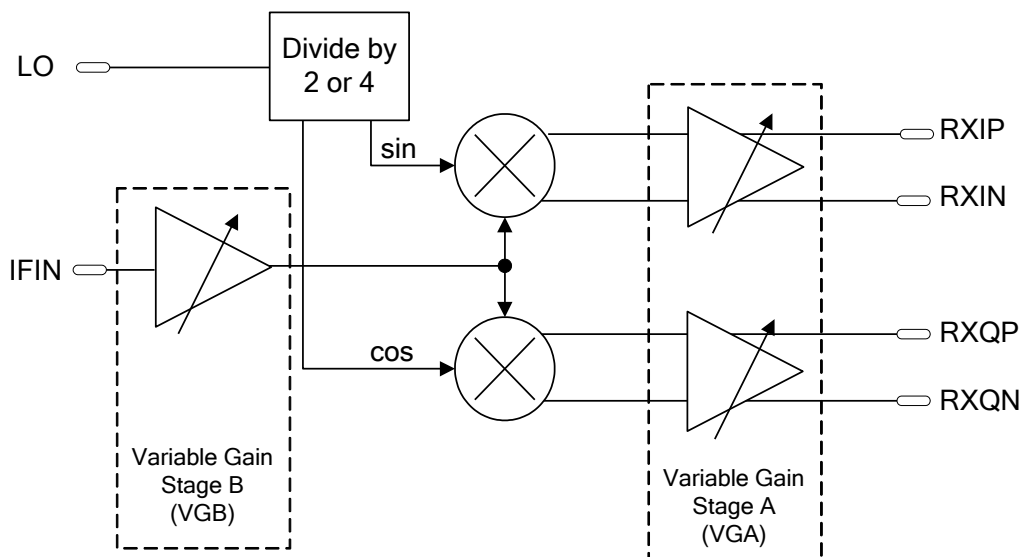

Figure 9 Demodulator Gain Control

The output of the quadrature demodulator is provided as a differential signal (pins RXIP, RXIN, RXQP and RXQN). The bandwidth of the I/Q signals depends on the OUTDRV bit (b7, \$1C, Rx Control Register, see section 6.3.1). The intermodulation performance of the CMX972 also depends on the OUTDRV bit, see section 7.2 for further details.

The CMX972 provides for an optimisation of receiver intermodulation using the “IMD” bits in the VCO control register, further details can be found in section 7.2.

5.1.1 I/Q Amplitude and Phase Correction

The LO path includes a correction circuit which may be enabled or disabled using the COR bit (b6 in the Rx Control Register \$1C), see section 6.3.1. This will improve the I/Q balance of the demodulator particularly when using the local oscillator divide by two (LO/2) mode; enabling this mode (COR='1') will

give a small increase in current consumption of typically 0.5mA. The improvement is most noticeable with higher frequency signals, e.g. circa 200 - 300MHz; at 45MHz the improvement is negligible.

Condition	250MHz		45MHz	
	RXIP/RXQP	RXIN/RXQN	RXIP/RXQP	RXIN/RXQN
\$1C, b6 = '0'	92.0°	92.0°	90.1°	90.2°
\$1C, b6 = '1'	89.8°	89.8°	89.9°	89.9°

Table 8 Typical Phase Balance, LO/2 Mode

At 250MHz I/Q amplitude balance is typically 0.12dB with COR = '0' and 0.04dB with COR = '1'. Enabling the correction circuit also reduces the I/Q path gain, particularly at higher frequencies. This can be compensated by setting the FREQ bits (b3-0 in the Rx Mode register \$1D) to '1111', instead of the default value of '0000'. I/Q path gain is restored at the expense of a slight degradation in I/Q phase balance of ≈0.5°. For many applications, the '1111' setting will be adequate.

At all frequencies, phase correction accuracy is improved by using a lower setting of the FREQ bits (b3-0 in the Rx Mode register \$1D). However, care should be taken to avoid significant gain degradation, which occurs if a setting near '0000' is chosen for a high frequency. Table 9 is a guide for the appropriate setting of the FREQ bits, so as to obtain the best phase balance (typically better than 0.06°) with only a small gain reduction (typically less than 0.6dB). Where frequency ranges overlap, either setting of the FREQ bits can be used.

Bit	b3	b2	b1	b0	Frequency
	0	1	0	0	20MHz to 40MHz
	1	0	0	0	40MHz to 80MHz
	1	1	0	0	80MHz to 200MHz
	1	1	0	1	200MHz to 240MHz
	1	1	1	0	240MHz to 300MHz

Table 9 Recommended FREQ bit Settings in the Rx Mode Register

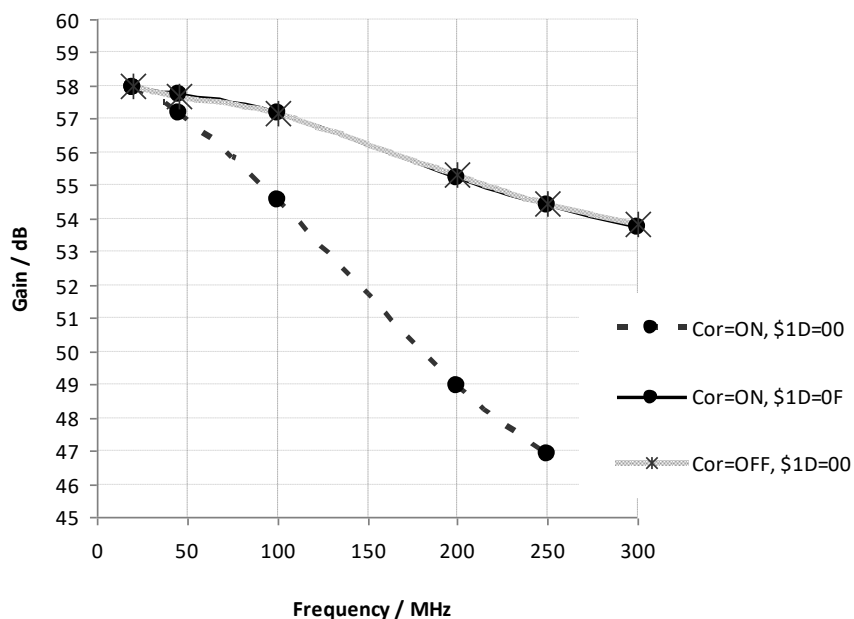

Figure 10 Frequency Response, showing effect of COR bit (\$1C, b6) and FREQ bits(\$1D, b3-b0)

Condition	Typical I/Q Phase Balance
COR = '0' \$1D = 0x00	87.95°
COR = '1' \$1D = 0x00	90.06°
COR = '1' \$1D = 0x0F	90.49°

Table 10 Effect of FREQ bits (\$1D, b3-b0) on I/Q Phase Balance at 250MHz

Condition	Typical I/Q Phase Balance
COR = '0' \$1D = 0x00, +20°C	87.3°
COR = '1' \$1D = 0x0F, -20°C	90.6°
COR = '1' \$1D = 0x0F, +20°C	90.6°
COR = '1' \$1D = 0x0F, +55°C	90.5°

Table 11 Effect of FREQ bits (\$1D, b3-b0) on I/Q Phase Balance at 300MHz with Temperature

5.1.2 DC Offset Correction

Digitally-controlled dc offset correction is provided which is capable of reducing the offset to 60mV or less for errors of up to +/-420mV. This represents a reduction in dynamic range of about 0.3dB for a typical ADC input signal range (2Vp-p) and is therefore negligible. The required correction must be measured externally as such measurements are application specific. The correction is applied close to the start of the I/Q baseband chain and therefore maximises dynamic range in the analogue sections.

The correction is applied in a differential manner so positive and negative corrections are possible, see Figure 11. This allows the dc to be corrected to the nominal dc bias level. The voltage sources are scaled in a binary fashion so multiple sources can be added to provide the desired correction. The same arrangement applies independently on both I and Q channels.

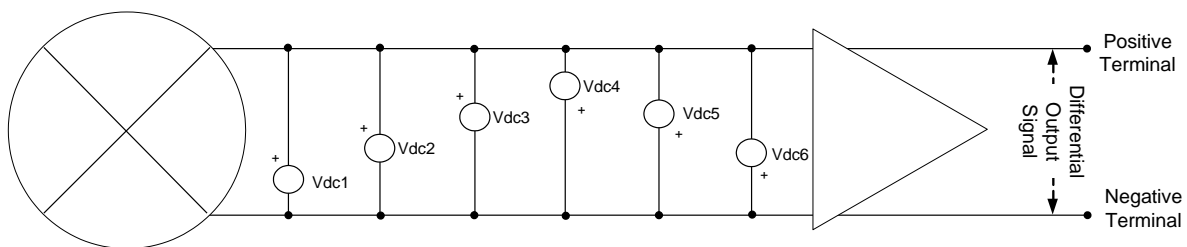

Figure 11 Simplified Schematic DC Offset Correction Circuit

Source	Voltage Correction at Output for Maximum Gain in Baseband Amplifiers	Correction Polarity
Vdc1	60mV	Positive terminal increase, Negative terminal decrease
Vdc2	120mV	Positive terminal increase, Negative terminal decrease
Vdc3	180mV	Positive terminal increase, Negative terminal decrease
Vdc4	60mV	Negative terminal increase, Positive terminal decrease
Vdc5	120mV	Negative terminal increase, Positive terminal decrease
Vdc6	180mV	Negative terminal increase, Positive terminal decrease

Table 12 DC Offset Correction Adjustments

5.2 Differential Amplifiers

A pair of differential amplifiers are provided which may be used to implement filtering or buffering. These uncommitted amplifiers may be used to implement Sallen-Key or Multiple Feedback (MFB) style filters, buffering or configured as needed.

The amplifiers are low power and are enabled using the General Control Register (see section 6.2.1). It is also possible for the amplifiers to be enabled with individual I and Q paths, see section 6.4.1.

5.3 Local Oscillator (LO)

The device allows for a flexible choice of routing for the LO input to the demodulator, to suit a variety of applications.

The options available, controlled by the General Control Register (see section 6.2.1), are as follows:

- The demodulator LO may be derived from the external input (RXLO) or from the internal VCO/PLL.
- The selected LO source is fed back to an integer-N PLL circuit which may be used to control the on-chip (or an external) VCO from its Charge Pump output (DO).

Three bits in the General Control Register are used to define the allowed states. The permitted combinations are shown in Table 13.

VCOEN \$1B, b3	PLLEN \$1B, b2	RXEN \$1B, b1	Function
0	0	0	All features disabled for low power
0	0	1	Use of demodulator with signal from RXLO pin
0	1	1	Use of demodulator with external VCO connected to RXLO using on-chip PLL
1	1	1	Use of demodulator with LO supplied by on-chip VCO and PLL
Note: Other combinations of control bit are illegal states and should not be used.			

Table 13 LO Connections

5.3.1 Demodulator LO Input

The RXLO pin is a single-ended input for the demodulator LO signal. Internal ac coupling is provided so an external dc blocking capacitor is not required. Note that the LO should be at twice or four times the desired input frequency.

5.3.2 VCO and PLL

The internal VCO may be connected to the internal PLL and the demodulator. If required, an external VCO can be connected to the PLL using the RXLO input, in this case the on-chip VCO must be disabled using bit 3 in the General Control Register (see section 6.2.1 and Table 13).

5.3.2.1 PLL

The PLL functions are shown in Figure 12. The output frequency of the PLL is set by the following calculation:

$$f_{\text{out}} = f_{\text{ref}} \times (M / R)$$

where

- f_{out} = The desired output frequency in MHz
- f_{ref} = The reference frequency supplied to the PLL on pin REFIN in MHz
- M = Divider value programmed in the M divider register (see section 6.6.1)
- R = Divider value programmed in the R divider register (see section 6.7.1)

also note that $f_{comparison} = f_{ref} / R$

The PLL only supports VCOs with a positive tuning slope, i.e. a high tuning voltage from DO results in a higher oscillation frequency from the VCO.

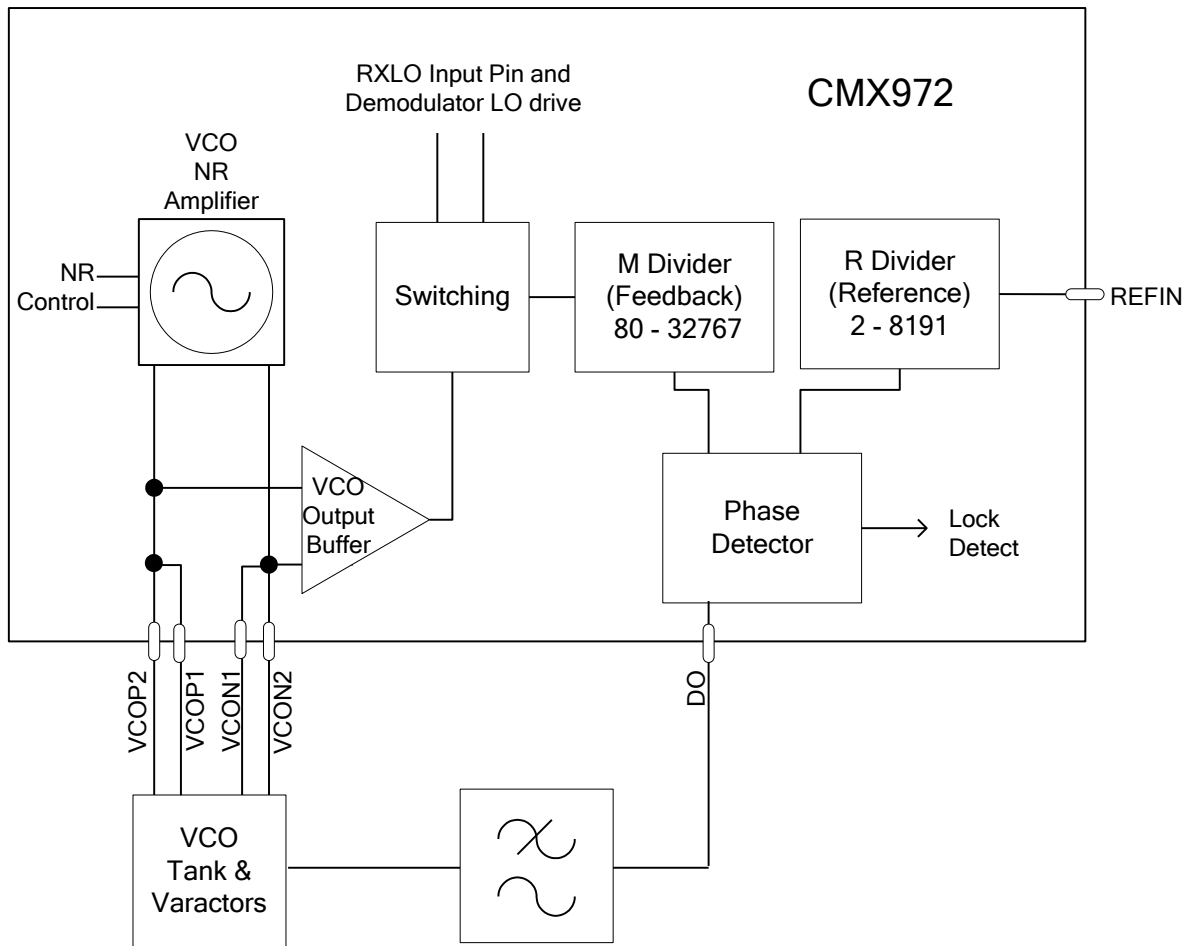

Figure 12 PLL Architecture

The PLL block has to be enabled from the General Control Register \$1B, b2 (section 6.2.1) and the PLL R Divider Register \$2C, b7 (section 6.7.1), i.e. an AND function is performed on these two bits.

General Control Register \$1B, b2	PLL R Divider Register \$2C, b7	PLL Enable
0	0	No
0	1	No
1	0	No
1	1	Yes

Table 14 PLL Control

The PLL provides a lock detect function which can be read via C-BUS register \$DC bit 6, see section 6.6.2. Register \$2C provides the facility for the PLL charge pump to be placed in a high-impedance state, this mode can be used, for example, to allow pre-steering of the VCO.

When using the CMX972 PLL, spurious products (spurs) in the receiver I/Q output may be observed. The level of the spurs varies and is typically different in I and Q channels. The frequency of the spurs is linked to the PLL M divider value, thus the comparison frequency and which of the divider modes (divide-by-2 or -4) is selected for the receiver LO circuits. Operation in divide-by-2 mode is most predictable: all even division ratios are problem free and all odd division ratios will give a spurious product at:

$$f_{\text{spur}} = f_{\text{lo}} / (M * 2)$$

In divide-by-4 mode odd divisions will produce a spur although at some low frequencies (e.g circa 100MHz) spur levels are much lower. At circa 300 MHz and above, even divisions are also problematic (in divide-by-4 mode).

It is recommended that for safe operation of the CMX972 PLL, receiver LO divide-by-2 with even division ratios, should be used.

5.3.2.2 VCO

The CMX972 VCO is a reflection oscillator that requires an external resonator circuit (see section 4.4) with the negative resistance (NR) generator on the device. The VCO Control Register (\$2F, section 6.8.1) provides a control of the magnitude of the negative transconductance for optimum phase noise performance. The NR minimum mode should be used with the low Q external tank circuit and NR maximum with the higher Q circuits. For further information see section 7.7.

6 C-BUS Interface and Register Description

The C-BUS serial interface supports the transfer of control and status information between the CMX972's internal registers and an external host. Each C-BUS transaction consists of the host sending a single Register Address byte, which may then be followed by zero or one data bytes that are written into the corresponding CMX972 register, as illustrated in Figure 13.

Data sent from the host on the Command Data (CDATA) line is clocked into the CMX972 on the rising edge of the Serial Clock (SCLK) input. The C-BUS interface is compatible with common μ C/DSP serial interfaces and may also be easily implemented with general-purpose I/O pins controlled by a simple software routine. Section 8.1.3.5 gives the detailed C-BUS timing requirements.

Whether a C-BUS register is of read or write type is fixed for a given C-BUS register address, thus it is not possible to read from and write to the same C-BUS register address.

In order to provide ease of addressing when using this device with other CML RF devices, the C-BUS addresses below are arranged so as not to overlap those used on the other CML RF Devices. Thus, a common chip select (CSN) signal can be used, as well as common CDATA, RDATA and SCLK signals. Also note that the General Reset (\$1A) command on the CMX972 differs from other CML devices (such as CMX991/CMX992/CMX993/CMX998), which use \$01 or \$10 for this function.

The following C-BUS register addresses are used:

Write Only register:

General Reset Register (Address only, no data)	Address \$1A
General Control Register, 8-bit write only	Address \$1B
Rx Control Register, 8-bit write only	Address \$1C
Rx Mode Register, 8-bit write only	Address \$1D
Rx Offset Correction Register, 8-bit write only	Address \$1F
IF PLL M Divider Register, 8-bit write only	Address \$2A-\$2C
IF PLL R Divider Register, 8-bit write only	Address \$2D-\$2E
VCO Control Register, 8-bit write only	Address \$2F

Read Only register:

General Control Register, 8-bit read only	Address \$EB
Rx Control Register, 8-bit read only	Address \$EC
Rx Mode Register, 8-bit read only	Address \$ED
Rx Offset Correction Register, 8-bit read only	Address \$EF
IF PLL M Divider Register, 8-bit read only	Address \$DA-\$DC
IF PLL R Divider Register, 8-bit read only	Address \$DD-\$DE
VCO Control Register, 8-bit read only	Address \$DF

Notes:

- The 8-bit write-only register (\$1E), which is reserved for future use, defaults to 0x00 on power-up. For minimum current consumption, this register should not be written to.
- All registers will retain data if VDD pin is held high, even if all other power supply pins are disconnected.
- If clock and data lines are shared with other devices V_{DD} must be maintained in its normal operating range otherwise ESD protection diodes may cause a problem with loading signals connected to SCLK, RDATA and CDATA pins, preventing correct programming of other devices.

Other supplies may be turned off and all circuits on the device may be powered down without causing this problem.

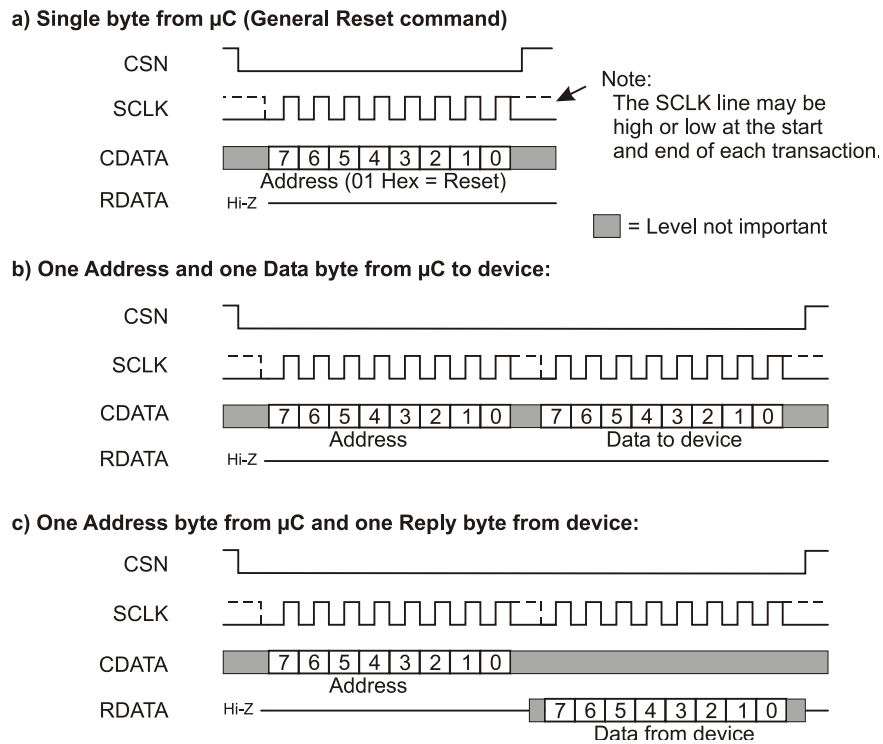

Figure 13 C-BUS Transactions

6.1 General Reset Command

6.1.1 General Reset Command - \$1A: no data

This command resets the device and clears all bits of all registers. The General Reset command places the device into powersave mode.

Whenever power is applied to the VDD pin, a built in power-on-reset circuit ensures that the device powers up into the same state as follows a General Reset command.

6.2 General Control Register

6.2.1 General Control Register - \$1B: 8-bit write

This register controls general features such as powersave.

All bits of this register are cleared to '0' during a General Reset command.

Bit:	7	6	5	4	3	2	1	0
	RXDIV	0	DIFAMP	ENBIAS	VCOEN	PLLEN	RXEN	0

General Control Register b7

Writing b7 = '1' the receiver LO is divided by 2; writing b7 = '0' the LO is divided by 4.

General Control Register b6

Reserved, set to '0'.

General Control Register b5 - b1

These bits control power up/power down of the various blocks of the IC.

In all cases '1' = power up, '0' = power down.

b5	Enable differential amplifiers (see also section 6.4.1)
b4	Enable bias
b3	Enable VCO (this bit also disables the RXLO input)
b2	PLL enable (see Table 14 and section 6.6.1) Note: To enable the PLL b7 of the PLL M-Divider Register (\$2C) also needs to be set.
b1	Enable quadrature demodulator

Note: b1-b3 also control local oscillator signal routing, see section 5.3 and Table 13.

General Control Register b0

Reserved, set to '0'.

6.2.2 General Control Register - \$EB: 8-bit read

This register reads the value in register \$1B, see section 6.2.1 for details of bit functions.

6.3 Rx Control Register

6.3.1 Rx Control Register - \$1C: 8-bit write

This register controls operational modes of the receiver such as gain setting.

All bits of this register are cleared to '0' by a General Reset command.

Bit:	7	6	5	4	3	2	1	0
	OUTDRV	COR	0	VGB2	VGB1	VGB0	VGA1	VGA0

Rx Control Register b7

Writing b7 = '1' the output drive capability of the demodulator I/Q output is increased, this mode allows the CMX972 to support wider bandwidth modulation and/or driver lower impedance loads; b7 = '0' is the default condition with best power efficiency.

Rx Control Register b6

Writing b6 = '1' enables the correction circuit in the quadrature demodulator. This will improve the I/Q phase balance of the demodulator particularly in LO/2 mode; enabling this mode increases the current consumption slightly. For further information see section 5.1.1.

With b6 = '0' this enhanced mode is disabled for optimum current consumption.

Rx Control Register b5

Reserved, must be cleared to '0' for correct operation.

Rx Control Register b4 – b2

Variable Gain (VGB) Control; these bits control the gain of the IF/RF amplifier reducing the gain from the maximum in 6dB steps.

Bit	b4	b3	b2	
	1	1	1	Reserved do not use
	1	1	0	Reserved do not use
	1	0	1	VG = -30dB
	1	0	0	VG = -24dB
	0	1	1	VG = -18dB
	0	1	0	VG = -12dB
	0	0	1	VG = -6dB
	0	0	0	VG = 0dB (maximum gain)

Rx Control Register b1 – b0

Variable Gain (VGA) control; this bits control the gain of the post-I/Q mixer baseband amplifiers reducing the gain from the maximum in 6dB steps.

Bit	b1	b0	
	1	1	VG = -18dB
	1	0	VG = -12dB
	0	1	VG = -6dB
	0	0	VG = 0dB (maximum gain)

6.3.2 Rx Control Register - \$EC: 8-bit read

This read-only register mirrors the value in register \$1C; see section 6.3.1 for details of bit functions.

6.4 Rx Mode Register**6.4.1 Rx Mode Register - \$1D: 8-bit write**

This register controls operational modes of the receiver.

All bits of this register are cleared to '0' by a General Reset command.

Bit:	7	6	5	4	3	2	1	0
	M1	M0	DIFAMPI	DIFAMPQ	FREQ3	FREQ2	FREQ1	FREQ0

Rx Mode Register b7 – b6

Bit	b7	b6	
	0	0	I and Q channels enabled
	0	1	Only I channel enabled
	1	0	Only Q channel enabled
	1	1	Reserved do not use

Rx Mode Register b5 - b4

With b4, b5 = '0' both differential amplifiers are enabled/disabled by the DIFAMP bit in the General Control Register (section 6.2.1). With b4 = '1' the Q channel differential amplifier control by the DIFAMP bit will be inverted. With b5 = '1' the I channel differential amplifier control by the DIFAMP bit will be inverted. This aids the applications where the amplifiers are associated with either the I or Q channels.

Bit	\$1B, b5	b5	b4	
	0	0	0	Diff Amp 1 = 'OFF'; Diff Amp 2 = 'OFF'
	0	0	1	Diff Amp 1 = 'OFF'; Diff Amp 2 = 'ON'
	0	1	0	Diff Amp 1 = 'ON'; Diff Amp 2 = 'OFF'
	0	1	1	Diff Amp 1 = 'ON'; Diff Amp 2 = 'ON'
	1	0	0	Diff Amp 1 = 'ON'; Diff Amp 2 = 'ON'
	1	0	1	Diff Amp 1 = 'ON'; Diff Amp 2 = 'OFF'
	1	1	0	Diff Amp 1 = 'OFF'; Diff Amp 2 = 'ON'
	1	1	1	Diff Amp 1 = 'OFF'; Diff Amp 2 = 'OFF'

Rx Mode Register b3 – b0

These bits optimise the operation of the receiver quadrature demodulator mixers by adjusting the LO signal. The bits adjust LO amplitude, which has an impact on mixer gain, but the adjustment also has an effect on quadrature accuracy. See also section 5.1.1. Note that if \$1C b6 is set to 0, so that phase correction is not used, the setting of these FREQ bits has no effect.

A setting of '0000' represents the optimum value for phase accuracy.

6.4.2 Rx Mode Register - \$ED: 8-bit read

This read-only register mirrors the value in register \$1D; see section 6.4.1 for details of bit functions.

6.5 Rx Offset Register

6.5.1 Rx Offset Register - \$1F: 8-bit write

All bits of this register are cleared to '0' by a General Reset command.

Bit:	7	6	5	4	3	2	1	0
	QDC3	QDC2	QDC1	QDC0	IDC3	IDC2	IDC1	IDC0

Rx Offset Register b7 – b0

I/Q DC offset correction, see section 5.1.2 for further details.

Bit	b3	b2	b1	b0	I Channel
	b7	b6	b5	b4	Q Channel
	1	1	1	1	-420mV
	1	1	1	0	-360mV
	1	1	0	1	-300mV
	1	1	0	0	-240mV
	1	0	1	1	-180mV
	1	0	1	0	-120mV
	1	0	0	1	-60mV
	1	0	0	0	No correction
	0	1	1	1	+420mV
	0	1	1	0	+360mV
	0	1	0	1	+300mV
	0	1	0	0	+240mV
	0	0	1	1	+180mV
	0	0	1	0	+120mV
	0	0	0	1	+60mV
	0	0	0	0	No correction

6.5.2 Rx Offset Register - \$EF: 8-bit read

This read-only register mirrors the value in register \$1F; see section 6.5.1 for details of bit functions.

6.6 PLL M Divider Register

6.6.1 PLL M Divider - \$2C - \$2A: 8-bit write

These registers set the M divider value for the PLL (Feedback divider). The PLL dividers are only updated when \$2C has been written, so this register should be written to last. Bits 7 and 5 also control the PLL and charge-pump blocks and these control bits are active as soon as \$2C is written. (Note: To enable the PLL, b2 of the General Control Register (\$1B) also needs to be set).

\$2C								\$2B							
7	6	5	4	3	2	1	0	7	6	5	4	3	2	1	0
E	LD_Synth	CP	0	0	0	M17	M16	M15	M14	M13	M12	M11	M10	M9	M8

\$2A							
7	6	5	4	3	2	1	0
M7	M6	M5	M4	M3	M2	M1	M0

M17:M0

Phase Locked Loop M divider value.

CP

\$2C, b5 = '1' enables the charge pump, \$2C b5 = '0' puts the charge pump into high-impedance mode.

LD Synth

Only write '0' to b6 of \$2C (when read, this shows the PLL lock status, see section 6.6.2).

E

\$2C, b7 = '1' enables the PLL; b7 = '0' disables the PLL – in this mode an external local oscillator may be supplied to the CMX972, see also section 5.3.2 and Table 14. (Note: To enable the PLL b2 of the General Control Register (\$1B) also needs to be set).

\$2C b4-b2

Reserved, set to '0'.

6.6.2 PLL M Divider - \$DC - \$DA: 8-bit read

These registers read the respective values in registers \$2C, \$2B and \$2A (\$DC reads back \$2C and \$DB reads back \$2B etc.); see section 6.6.1 for details of bit functions.

N.B. \$DC b6 indicates the Synthesiser lock detect status.

6.7 PLL R Divider Register**6.7.1 PLL R Divider - \$2E - \$2D: 8-bit write**

These registers set the R divider value for the PLL (Reference divider). The PLL dividers are only updated when \$2E has been written, so this register should be written to last.

\$2E								\$2D								
Bit:	7	6	5	4	3	2	1	0	7	6	5	4	3	2	1	0
	R15	R14	R13	R12	R11	R10	R9	R8	R7	R6	R5	R4	R3	R2	R1	R0

R15:R0

Phase Locked Loop R divider value.

6.7.2 PLL R Divider - \$DE - \$DD: 8-bit read

These registers read the respective values in registers \$2E and \$2D (\$DE reads back \$2E and \$DD reads back \$2D); see section 6.7.1 for details of bit functions.

6.8 VCO Control Register**6.8.1 VCO Control Register - \$2F: 8-bit write**

This register optimises the operation of the VCO. Note the VCO is enabled when b3 = '1' in the General Control register (\$1B), as detailed in section 6.2.

All bits of this register are cleared to '0' by a General Reset command.

Bit:	7	6	5	4	3	2	1	0
	IMD5	IMD4	IMD3	IMD2	IMD1	IMD0	VCONR2	VCONR1

VCO Control Register b7 – b2

These bits allow the user to adjust the intermodulation performance of the Rx I/Q mixers. The default value is '0' for all the bits. Improved intermodulation can be achieved with a particular value in these bits. The recommended value for optimum performance is '111111'. This value does not vary between devices or with frequency. For further details see section 7.2.

VCO Control Register b1 – b0

VCO amplifier Negative Resistance (NR) control for optimum phase noise performance, see section 5.3.2.2.

Bit:

b2	b1	
0	0	NR maximum (highest Q tank circuit)
0	1	NR Intermediate value
1	0	NR Intermediate value
1	1	NR minimum (lowest Q tank circuit)

6.8.2 VCO Control Register - \$DF: 8-bit read

This register reads the value in register \$2F, see section 6.8.1 for details of bit functions.

7 Application Notes

7.1 IF/RF Input Matching

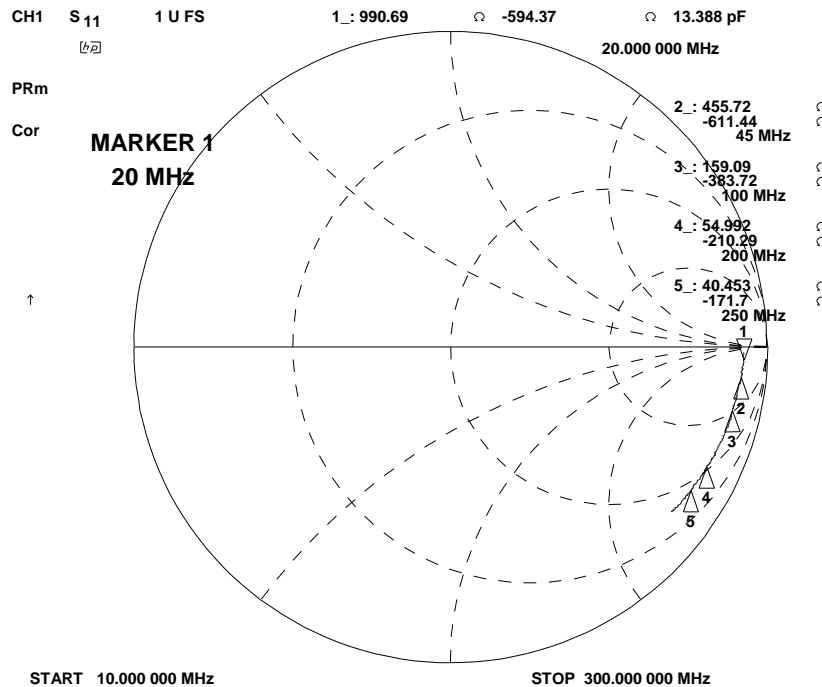

Figure 14 Quadrature Demodulator Input Impedance (10MHz to 300MHz)

Frequency (MHz)	Typical Impedance (Ω -/+j Ω)	Parallel Equivalent Circuit (R//pF)
20	991 - j594	1.35kR // 3.5pF
45	456 - j611	1.28kR // 3.7pF
100	159 - j384	1.08kR // 3.5pF
200	55 - j210	860.5R // 3.5pF
250	41 - j172	768.4R // 3.5pF

Table 15 Quadrature Demodulator Input Impedances and Parallel Equivalent Circuit

The typical input impedance of the IFIN port is shown in Figure 14 and Table 15. The configuration of the IF input has a significant effect on the measured performance. This is demonstrated in Table 16, where the receiver is measured with a 50 Ohm source and three different input conditions. A matched network (e.g. as shown in section 4.2) provides the best noise figure and maximum gain, however intermodulation will be degraded in this condition due to the larger signal levels indicated by the extra gain. The 'straight in' condition means that the 50 Ohm signal source was connected directly at IFIN.

Input Condition	Noise Figure / dB	Gain / dB
50R shunt resistor	16.3	50.5
matched network	7.8	64
straight in	10	56

Table 16 Typical Noise Figure and Gain of IF Amp, VGA and I/Q Mixer

The gain in the 'straight in' case is based on direct conversion of the signal generator power to a voltage and calculating the gain based on the output voltage. The output signal is the differential signal at RXIN and RXIP (or RXQN and RXQP) so if the voltage is measured at a single pin the signal level must be doubled to get the appropriate differential signal level. Also it should be noted that making a simple conversion of the power in the 'straight in' case is erroneous as the voltage calculated will be a potential difference. As the circuit is unmatched an e.m.f. would be more appropriate (i.e. twice the potential difference value).

7.2 Demodulator Intermodulation and Output Drive Capability

The intermodulation performance of the demodulator may be optimised by use of the output drive bit (register \$1C b7, see section 6.3.1). Performance can be further optimised by setting the IMD bits in the VCO register (register \$2F b2 to b7) to '111111' = 63 decimal.

IMD bits setting (register \$2F b2 to b7) decimal value	\$1C, b7='0' 50kHz and 100kHz tones	\$1C, b7='1' 50kHz and 100kHz tones	\$1C, b7='0' 500kHz and 1MHz tones	\$1C, b7='1' 500kHz and 1MHz tones
0	-23 dBm	-12 dBm	-24 dBm	-12 dBm
63	-19 dBm	-11 dBm	-24 dBm	-11 dBm

Table 17 Typical Third Order Intercept Performance of demodulator at 45MHz (straight-in case)

7.3 Variation with Temperature

The CMX972 demodulator exhibits excellent temperature stability. Typical variation of the receive path gain is shown in Figure 15. The I/Q gain/phase balance (see Table 10), dc level and attenuator steps also show only small variations with temperature.

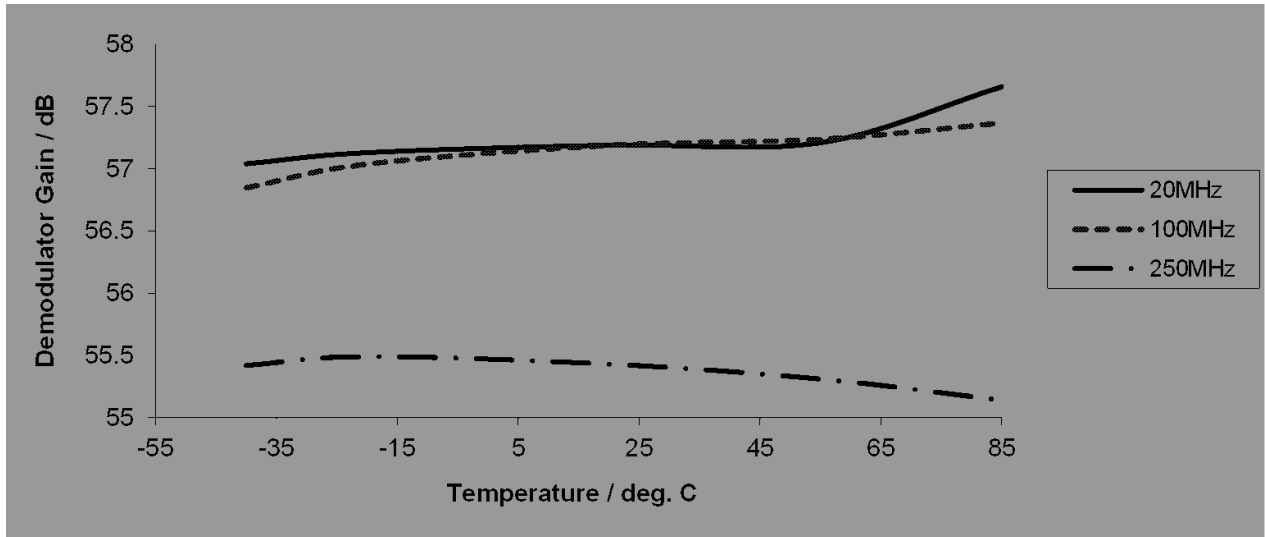

Figure 15 Demodulator Gain Variation With Temperature

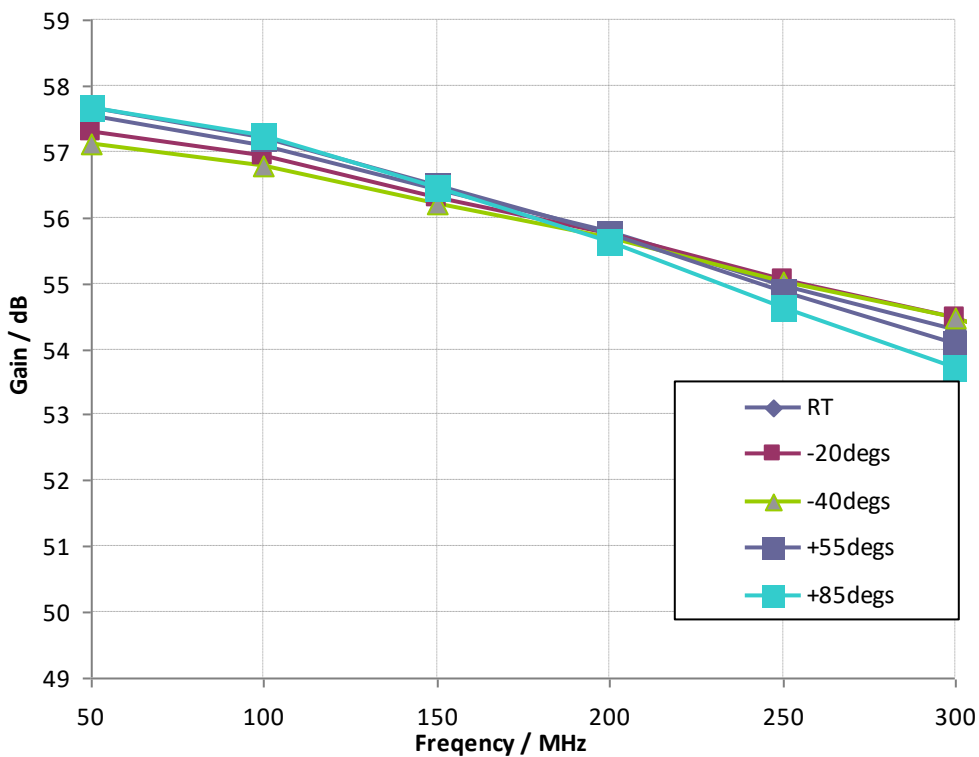

Figure 16 Variation in Gain with Temperature (COR = '0' \$1D = 0x00)

7.4 Effect of Gain Control on Receiver Performance

The CMX972 has two independent gain control elements: VGA is gain control applied in the I/Q sections and VGB is gain control in the RF/IF sections. Further details can be found in section 5.1. The gain can be controlled in 6dB steps via the Rx Control Register (see section 6.3).

The control of gain using VGA and VGB has an impact on the performance of the CMX972 demodulator section. The variation in noise figure (NF) is straightforward, with the RF/IF gain control (VGB) having a direct impact on NF but, due to the gain before the I/Q section, VGA has little impact on NF (see Figure 17). The variation of intermodulation (IMD) is more complex, as shown in Figure 18, where performance is characterised by 'Input Third Order Intercept Point' (IIP3). At maximum gain IIP3 is at a minimum and as would be expected, the IIP3 increases as the RF/IF gain is reduced (VGB). The improvement plateaus beyond the -18dB gain setting as the input stages limit performance at this level. Reduction in gain with VGA (I/Q gain control) also has a positive effect on IIP3. This is perhaps less intuitive but indicates that the intermodulation performance of the CMX972 demodulator chain is dominated by the output stages rather than RF/IF or mixer stages. Thus -6dB or even -12dB VGA gain control settings can be used to achieve improved IMD performance for negligible change in noise figure (Figure 17), as long as the reduction in gain can be tolerated.

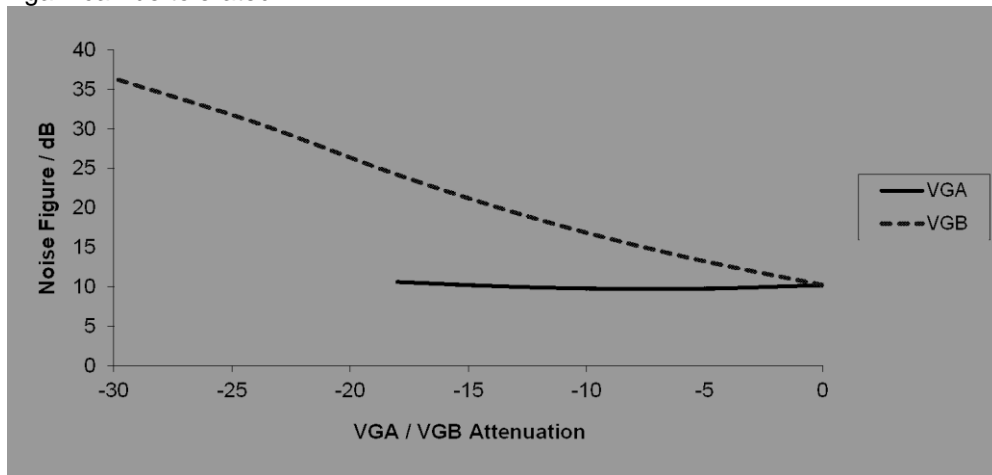

Figure 17 Variation in CMX972 Demodulator Noise Figure with VGA/VGB Control

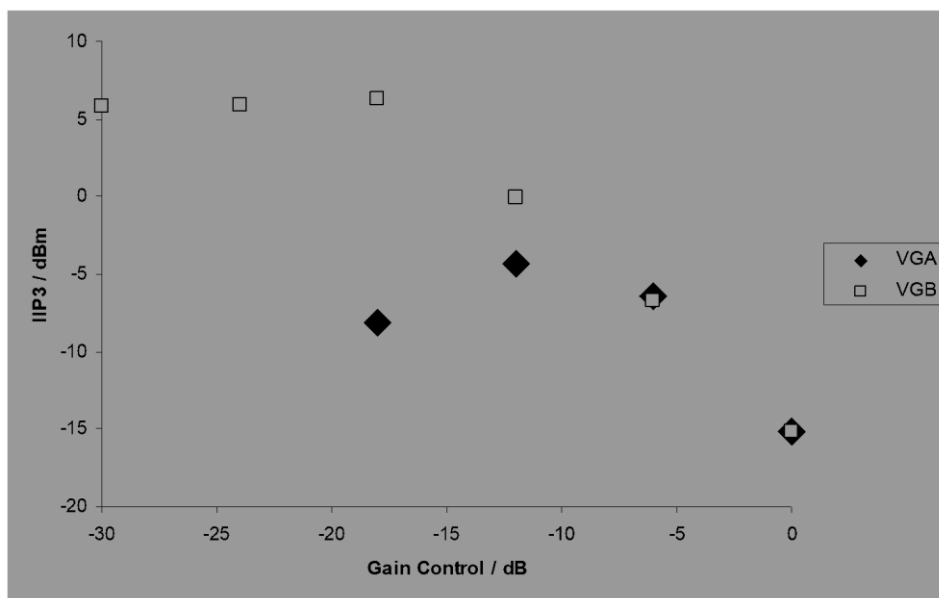

Figure 18 Variation in Input Third Order Intercept Point with VGA/VGB Control

7.5 Measurement of CMX972 Demodulator Intermodulation Performance

The measurement of the intermodulation (IMD) performance of the CMX972 demodulator requires great care because generally the IMD products are at a very low level. As a result, it is important to ensure products being measured are generated by the CMX972, not the measurement instrument or the test system.

It is also important to ensure that measurements are taken before the onset of clipping in the I/Q output stages – the effect is shown in Figure 19. Considering the graph, at signal levels below –51dBm per tone (two tone signal, tones of equal amplitude) the measured IMD product rises at the classical rate of 2dB for every 1dB increase in tone level. For input levels above –51dBm the rate of increase rises dramatically due to the onset of clipping. The effect can be seen in the plots of the composite signal: the calculated line is based on a calculation of the peak-to-peak swing of the output I/Q voltage from measured tone level at the output of the CMX972, however the actual output level is also plotted and the two lines deviate at the on-set of clipping.

It will be apparent that any calculation of IMD parameters, e.g. input third order intercept point, from measurements taken after the onset of clipping will give erroneous results if trying to characterise receiver operation at normal signal levels.

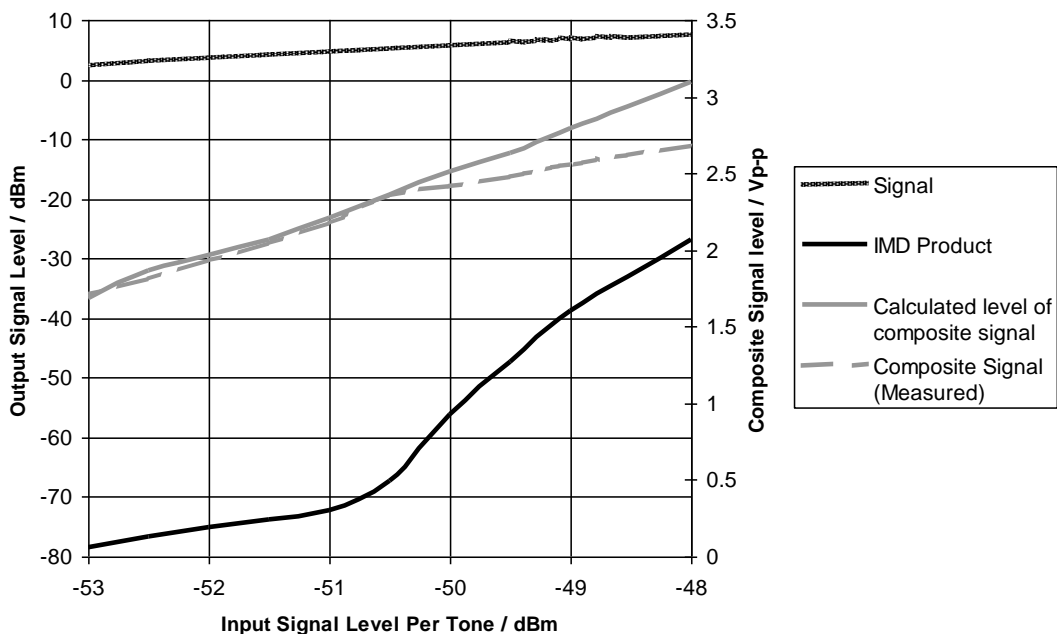

(Note: the two curves ‘Signal’ and ‘IMD Product’ are levels in dBm so should be referenced to the left hand Y-axis; the other curves are output voltages and use the right hand Y-axis.)

Figure 19 Variations in Signal and IMD Product Levels

Typical IMD measurements for the CMX972 demodulator usually involve IMD products at least 75dB below the wanted signal.

The input level where compression commences will vary somewhat from device to device, the value of -44.5dBm¹ (Figure 19) is typical but should only be used as an initial guide.

¹ Note: -50.5 dBm per tone = -44.5 dBm PEP,

7.6 Operation with large input signals

The input 1dB gain compression point of the CMX972 will vary depending on the settings of the VGA and VGB gain stages. Typical results with a 45 MHz signal, 50 ohm source, 'straight in' are as follows:

VGA = 0dB, VGB = 0dB	Input 1dB compression point = -42dBm
VGA = -18dB, VGB = 0dB	Input 1dB compression point = -25dBm
VGA = -18dB, VGB = -12dB	Input 1dB compression point = -12dBm
VGA = -18dB, VGB = -24dB	Input 1dB compression point = +5dBm

The above results are with the OUTDRV bit set to '1' and the IMD5-IMD0 bits in register \$2F='000000'. For optimum intermodulation performance the IMDn bits should be set to '111111' which has the effect of reducing the gain by about 1dB thus improving the input compression point by 1dB.

At high input signal levels the output of the CMX972 can start to reduce. Typical performance at maximum and minimum gain settings is shown in Figure 20, measured at 45MHz, setting as above. The output level is shown in dBm, this is measured by buffering the differential I/Q output signals (voltage), converting to single-ended and then measuring as power based on 50 Ohms.

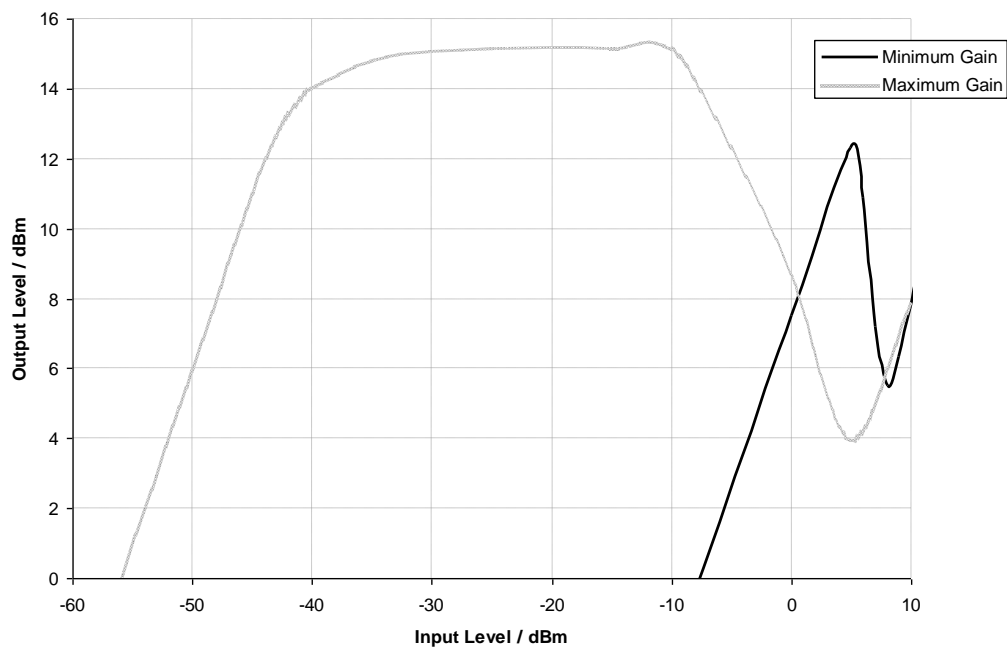

Figure 20 Output Signal Level Variations with Large Input Signals

7.7 VCO Phase Noise

The performance of the negative resistance VCO can be optimised by use of the VCONR bits in the VCO control register (\$2F, b1-b0, see section 6.8.1). For example, the typical change in phase noise and tuning voltage with VCONR setting is shown in Table 18 for the 180 MHz VCO described in Figure 5 / Table 4.

VCONR setting (\$2F, b1-b0)	Vtune (V)	Phase Noise at 10kHz offset, from $f_{vco}/2$ (dBc/Hz)
Maximum	2.425	-105.7
Intermediate 1	2.335	-107.1
Intermediate 2	2.235	-109.0
Minimum	2.183	-110.0

Table 18 Effect of VCONR bits, $f_{vco} = 180$ MHz, divide-by-2

The phase noise achieved by the CMX972 VCO depends on the VCO gain (K_v). The effect is shown in Figure 21, which plots the phase noise measured at 90 MHz (180 MHz VCO as Figure 5 / Table 4, divide-by-2 mode) as a function of the VCO gain.

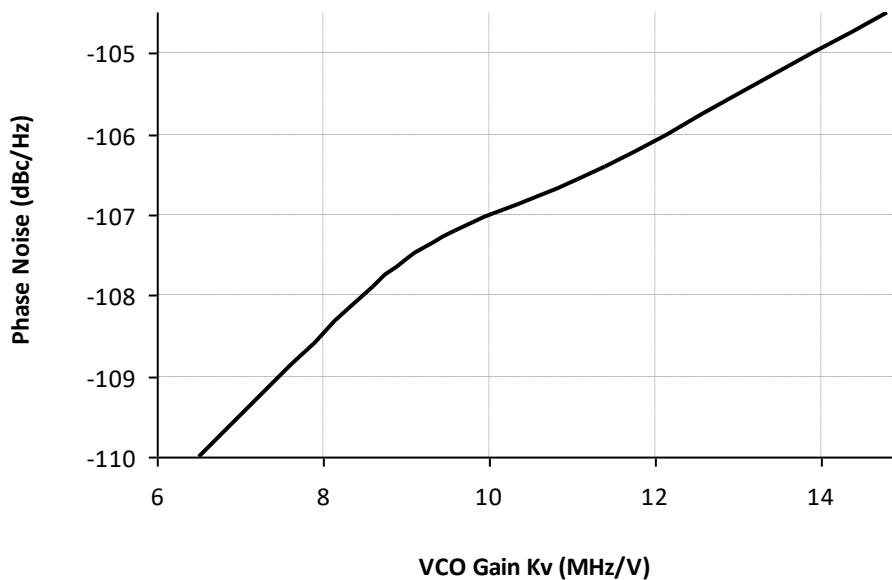

Figure 21 Effect of VCO Gain on Phase Noise

8 Performance Specification

8.1 Electrical Performance

8.1.1 Absolute Maximum Ratings

Exceeding these maximum ratings can result in damage to the device.

	Min.	Max.	Units
Supply ($V_{DD} - V_{SS}$) or ($V_{CC} - V_{RFGND}$) or ($V_{CCSYNTH} - V_{RFGND}$)	-0.3	+4.0	V
Voltage on any pin to V_{SS} or V_{RFGND}	-0.3	$V_{DD} + 0.3$	V
Voltage between pins RFGND and VSS	-50	+50	mV
Voltage between pins VCC and VCCSYNTH	-0.3	+0.3	V
Current into or out of RFGND, VSS, VCC, VCCSYNTH or VDD pins	-75	+75	mA
Current into or out of any other pin	-30	+30	mA

Q5 Package	Min.	Max.	Units
Total Allowable Power Dissipation at $T_{AMB} = 25^{\circ}\text{C}$	–	1410	mW
... Derating (see Note below)	–	14.1	mW/ $^{\circ}\text{C}$
Storage Temperature	-55	+125	$^{\circ}\text{C}$
Operating Temperature	-40	+85	$^{\circ}\text{C}$

Note: Junction-to-ambient thermal resistance is dependent on board layout and mounting arrangements. The derating factor stated will be better than this with good connection between the device and a ground plane or heat sink.

8.1.2 Operating Limits

	Notes	Min.	Max.	Units
Analogue Supply ($V_{CC} - V_{RFGND}$)		3.0	3.6	V
Digital Supply ($V_{DD} - V_{SS}$)		3.0	3.6	V
Operating Temperature (see Note above)		-40	+85	$^{\circ}\text{C}$

8.1.3 Operating Characteristics

8.1.3.1 DC Parameters

For the following conditions unless otherwise specified:

$V_{CC} = V_{CCSYNTH} = V_{DD} = 3.3V$; $V_{RFGND} = V_{SS} = 0V$. RXLO Level = -10dBm and $T_{AMB} = +25^{\circ}C$.

DC Parameters	Notes	Min.	Typ.	Max.	Units
Total Current Consumption	1				
Powersave Mode	2	–	7	70	μA
Bias Only		–	1.7	2	mA
Operating Currents					
Rx Only	4	–	15	19	mA
PLL and VCO	5	–	9	12	mA
Additional Current with DIFFAMP='1'	6	–	0.85	1.5	mA
Logic '1' Input Level		70%	–	–	V_{DD}
Logic '0' Input Level		–	–	30%	V_{DD}
Logic Input Leakage Current ($V_{in} = 0$ to V_{DD})		-1.0	–	+1.0	μA
Output Logic '1' Level ($I_{OH} = 0.6$ mA)		80%	–	–	V_{DD}
Output Logic '0' Level ($I_{OL} = -1.0$ mA)		–	–	+0.4	V
Power Up Time					
Voltage Reference	7	–	–	0.5	ms
All Blocks Except Voltage Reference	7	–	–	10	μs

Notes:

1. Total current, V_{DD} , V_{CC} and $V_{CCSYNTH}$.
2. Clock input (REFIN pin) not active; powersave mode includes the case after general reset with all analogue and digital supplies applied and also the case with V_{DD} applied but with V_{CC} and $V_{CCSYNTH}$ supplies disconnected (i.e. in this latter scenario power from V_{DD} will not exceed the specified value, whatever the state of the registers), not including any current drawn from device pins by external circuitry.
3. Void
4. Only Rx and Bias sections active.
5. Only Bias, PLL and VCO sections active.
6. DIFFAMP bit in General Control Register, see section 6.2.1, combined current for both differential amplifiers
7. Time from the rising edge of the last serial clock input following CSN being asserted for a write to the appropriate control register.

8.1.3.2 AC Parameters

For the following conditions unless otherwise specified:

$V_{CC} = V_{CCSYNTH} = V_{DD} = 3.3V$; $V_{RFGND} = V_{SS} = 0V$. and $T_{AMB} = +25^{\circ}C$.

AC Parameters	Notes	Min.	Typ.	Max.	Units
Differential Amplifiers					
Gain Bandwidth Product		40	70	–	MHz
Input Offset Voltage		–	1	–	mV
Input Common Mode Range		1.0	1.6	2.5	V
Input Bias Current		–	0.4	–	μA
Input Resistance		–	160	–	$k\Omega$
Slew Rate		–	6	–	$V/\mu s$
Differential Input Voltage		–	–	2	Vp-p
Input Referred Noise at 1kHz		–	15	–	nV/\sqrt{Hz}
DC Output Range		V_{RFGND+} 0.1	–	V_{RFGND-} 0.1	V
Output Load	11	–	1k Ω //100pF	–	

Notes:

10. Local oscillator input frequency twice or four times the required operating frequency.
11. Operating into a virtual earth (not ground).

8.1.3.3 AC Parameters – Demodulator

For the following conditions unless otherwise specified:

$V_{CC} = V_{CCSYNTH} = V_{DD} = 3.3V$; $V_{RFGND} = V_{SS} = 0V$. RXLO Level = -10dBm and $T_{AMB} = +25^{\circ}C$.

IF Amplifier and Quadrature Demodulator	Notes	Min.	Typ.	Max.	Units
Gain	30,31	–	56	–	dB(V/V)
Noise Figure	30,31	–	10	–	dB
Input Third Order Intercept Point	30,34	–	-15	–	dBm
Input Frequency Range		20	–	300	MHz
RXLO Frequency Range		40	–	600	MHz
Input Impedance	31	–	1000	–	Ω
Output Impedance		–	200	–	Ω
Output Load					
Resistance (differential)	33	10	–	–	k Ω
Capacitance per Pin	33	–	–	10	pF
Differential Output Voltage	33	2	–	–	Vp-p
Output Common Mode Voltage		$V_{CC} - 1.9$	$V_{CC} - 1.7$	$V_{CC} - 1.5$	V
RXLO Leakage at Input		–	-80	-40	dBm
Input 1dB Compression Point	30, 34,35	–	-41	–	dBm
VGA Control Range	32	–	18	–	dB
VGB Control Range	32	–	30	–	dB
VGA and VGB Step Size		4	6	8	dB
I/Q Gain Matching Error		–	0.1	0.5	dB
I/Q Phase Matching Error		–	0.1	1	degree
I/Q Output Bandwidth (-3dB)	33	5	10	–	MHz

Notes:

30. Measured from an unmatched 50 Ω input source to a differential I or Q output voltage; test frequency = 45MHz. Note that values include combined response of IF amplifier, quadrature demodulator and I/Q amplifier stages; at maximum VGA and VGB setting (0dB).
31. See also section 7.1.
32. Four VGA steps and six VGB steps, see Rx Control Register, section 6.3.1.
33. Differential Output Voltage is achieved with default output drive setting (register \$1C, b7='0', see section 6.3.1), for given output load and for at least the minimum I/Q output bandwidth; typical I/Q output bandwidth is achieved with increased drive capability selected (register \$1C, b7='1', see section 6.3.1) and with the same output load specification.
34. With increased output drive setting (register \$1C, b7='1').
35. With IMD5 – IMD0 (b7 – b2 of register \$2F) set to '111111'

8.1.3.4 AC Parameters – Integer N PLL and VCO

For the following conditions unless otherwise specified:

$V_{CC} = V_{CCSYNTH} = V_{DD} = 3.3V$; $V_{RFVDD} = V_{SS} = 0V$. RXLO Level = -10dBm and $T_{amb} = +25^{\circ}C$.

	Notes	Min.	Typ.	Max.	Unit
Phase Locked Loop					
<i>Reference Input</i>					
Frequency		5	–	30	MHz
Level	40	–	0.5	–	Vp-p
Divide Ratios (R Counter)		2	–	8191	
<i>Synthesiser</i>					
Comparison Frequency ($f_{comparison}$)		1	–	500	kHz
Input Frequency Range		40	–	1000	MHz
Input Level		-20	–	-5	dBm
Divide Ratios (M Counter)		80	–	32767	
Charge Pump Current		–	± 2.5	–	mA
1Hz Normalised Phase Noise Floor	43	–	-216	–	dBc/Hz
Negative Resistance VCO					
Supply Current (Enabled)		–	3	–	mA
Frequency Range	41	40	–	1000	MHz
Phase Noise at 10kHz Offset	42	–	-104	–	dBc/Hz
Phase Noise at 100kHz Offset	42	–	-118	–	dBc/Hz
RXLO Input					
Input Level		–	-10	–	dBm
Frequency Range		40	–	1000	MHz

Notes:

40. Sinewave or clipped sinewave.
41. Operation will depend on the choice and layout of external resonant components.
42. With external components from section 4.4 (Table 4) forming a 180MHz VCO; negative resistance bits set to minimum ($\$2F$, $b1-b0 = '11'$); phase noise quoted at VCO operating frequency but will normally be improved by the divider circuits in the demodulator LO path.
43. 1Hz Normalised Phase Noise Floor (PN1Hz) can be used to calculate the phase noise within the PLL loop bandwidth by: Measured Phase Noise (in 1Hz) = $PN1Hz + 20\log_{10}(M) + 10\log_{10}(f_{comparison})$.

8.1.3.5 C-BUS

C-BUS Timings (See Figure 22)	Notes	Min.	Typ.	Max.	Units
t_{CSE}	CSN-Enable to Clock-High Time	100	–	–	ns
t_{CSH}	Last Clock-High to CSN-High Time	100	–	–	ns
t_{LOZ}	Clock-low to reply output enable time	0.0	–	–	ns
t_{HIZ}	CSN-high to reply output 3-state time	–	–	1.0	μ s
t_{CSOFF}	CSN-High Time between transactions	1.0	–	–	μ s
t_{NXT}	Inter-Byte Time	200	–	–	ns
t_{CK}	Clock-Cycle Time	200	–	–	ns
t_{CH}	Serial Clock (SCLK) - High Time	100	–	–	ns
t_{CL}	Serial Clock (SCLK) - Low Time	100	–	–	ns
t_{RDS}	Reply Data (RDATA) - Set-Up Time	50.0	–	–	ns
t_{RDH}	Reply Data (RDATA) – Hold Time	0.0	–	–	ns
t_{CDS}	Command Data (CDATA) - Set-Up Time	75.0	–	–	ns
t_{CDH}	Command Data (CDATA) – Hold Time	25.0	–	–	ns

Maximum 30pF load on each C-BUS interface line.

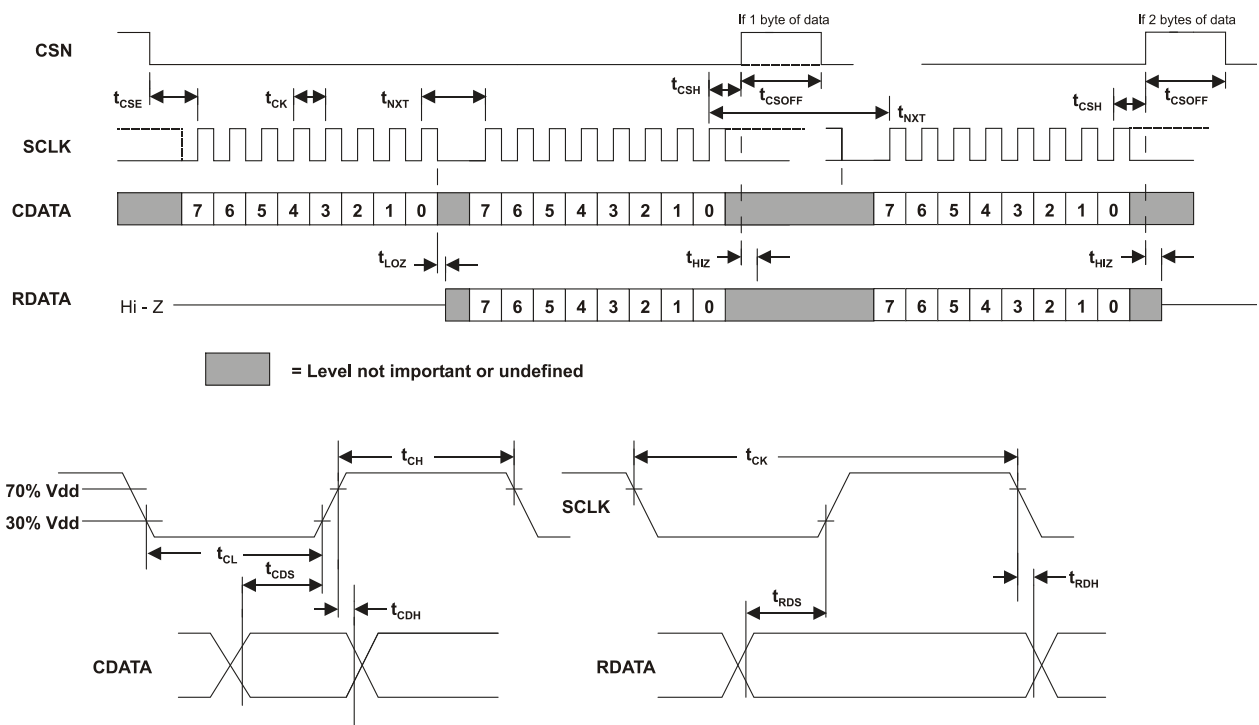

Note: Only 1 byte of data is used in CMX972 C-BUS transactions.

Figure 22 C-BUS Timing

8.2 Packaging

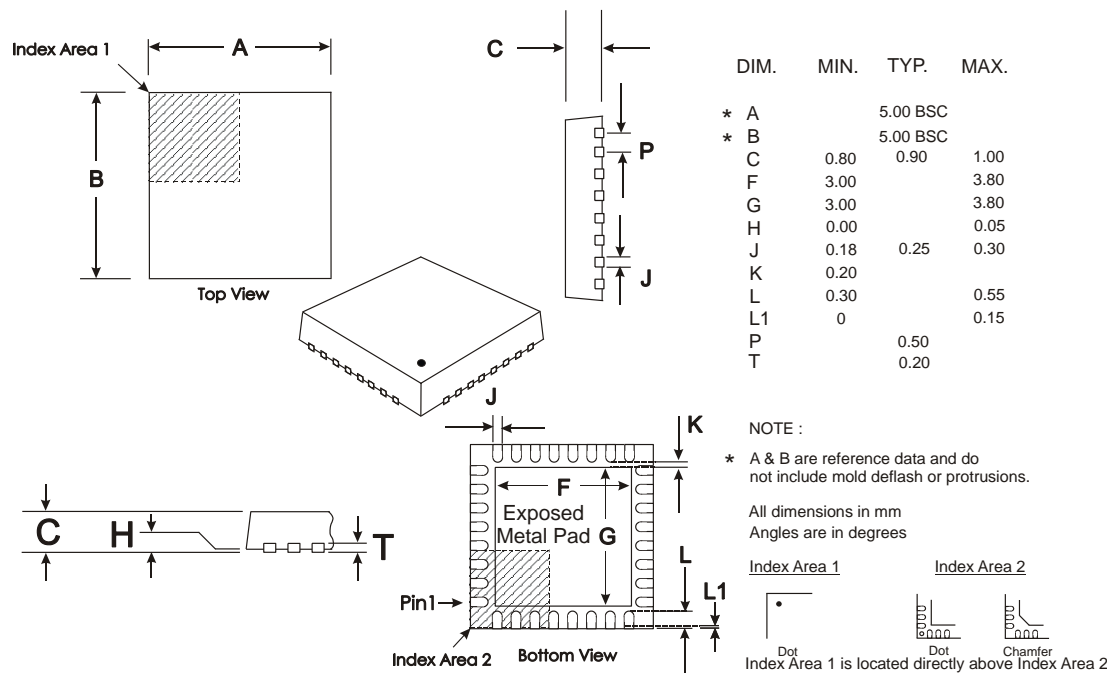

Depending on the method of lead termination at the edge of the package, pull back (L1) may be present. L minus L1 to be equal to, or greater than 0.3mm
 The underside of the package has an exposed metal pad which should ideally be soldered to the pcb to enhance the thermal conductivity and mechanical strength of the package fixing. Where advised, an electrical connection to this metal pad may also be required

Figure 23 Q5 Mechanical Outline: Order as part no. CMX972Q5

Handling precautions: This product includes input protection, however, precautions should be taken to prevent device damage from electro-static discharge. CML does not assume any responsibility for the use of any circuitry described. No IPR or circuit patent licences are implied. CML reserves the right at any time without notice to change the said circuitry and this product specification. CML has a policy of testing every product shipped using calibrated test equipment to ensure compliance with this product specification. Specific testing of all circuit parameters is not necessarily performed.

 CML Microcircuits (UK) Ltd COMMUNICATION SEMICONDUCTORS	 CML Microcircuits (USA) Inc. COMMUNICATION SEMICONDUCTORS	 CML Microcircuits (Singapore) Pte Ltd COMMUNICATION SEMICONDUCTORS
Tel: +44 (0)1621 875500 Fax: +44 (0)1621 875600 Sales: sales@cmlmicro.com Tech Support: techsupport@cmlmicro.com	Tel: +1 336 744 5050 800 638 5577 Fax: +1 336 744 5054 Sales: us.sales@cmlmicro.com Tech Support: us.techsupport@cmlmicro.com	Tel: +65 62 888129 Fax: +65 62 888230 Sales: sg.sales@cmlmicro.com Tech Support: sg.techsupport@cmlmicro.com
- www.cmlmicro.com -		

Mouser Electronics

Authorized Distributor

Click to View Pricing, Inventory, Delivery & Lifecycle Information:

[CML Microcircuits:](#)

[CMX972Q5](#) [CMX972Q5-REEL](#)