

MagLev Green Motor Blower
Power Motor Blower



MagLev Green Motor Blower

2.3~4.7 CFM



Model	P/N	Bearing ● VAPO ⊙ 2BALL	Rating Voltage (VDC)	Power Current (AMP)	Power Consumption (WATTS)	Speed (RPM)	Air Flow (CFM)	Static Pressure (Inch-H ₂ O)	Noise (dBA)	Weight (g)
GB1205PHVX-8AY	GN	●	12	0.18	2.2	6000	4.7	0.97	42.2	30
GB1205PHV1-8AY	GN	●	12	0.11	1.3	5000	4.0	0.67	39.8	30
GB1205PHV2-8AY	GN	●	12	0.06	0.7	4000	3.0	0.40	33.4	30
GB1205PHV3-8AY	GN	●	12	0.04	0.5	3000	2.3	0.16	27.0	30

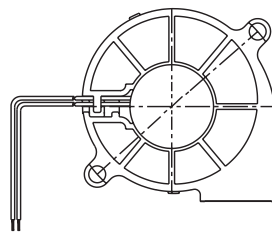
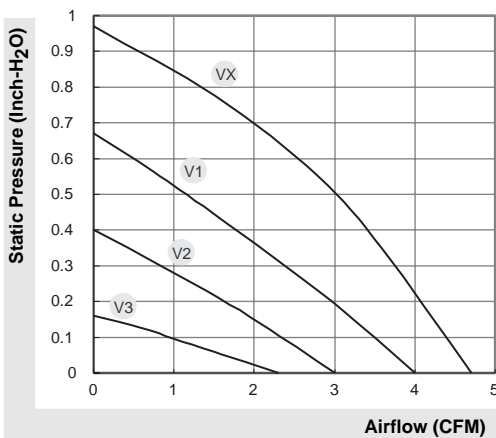

(Units : mm)

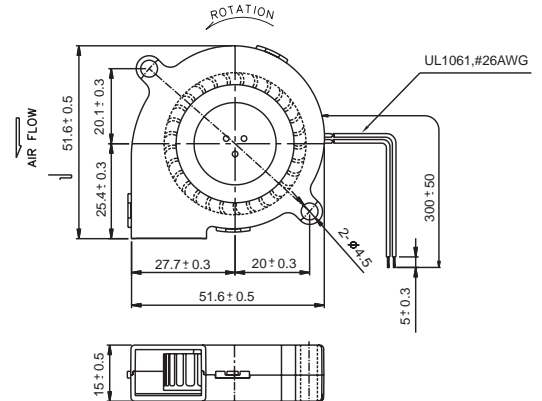

*All model could be customized on voltage or any other requirements to fit your need.

*Specifications subject to change without notice. Please Visit SUNON web site at <http://www.sunon.com> for update information.

MagLev Green Motor Blower

4.8~5.7 CFM



Model	P/N	Bearing ● VAPO ⊕ 2BALL	Rating Voltage (VDC)	Power Current (AMP)	Power Consumption (WATTS)	Speed (RPM)	Air Flow (CFM)	Static Pressure (Inch-H ₂ O)	Noise (dBA)	Weight (g)
GB1205PKV1-8AY	GN	●	12	0.12	1.4	5200	5.7	0.66	35	33
GB1205PKV2-8AY	GN	●	12	0.10	1.2	4800	5.2	0.56	33	33
GB1205PKV3-8AY	GN	●	12	0.08	1.0	4400	4.8	0.46	30	33

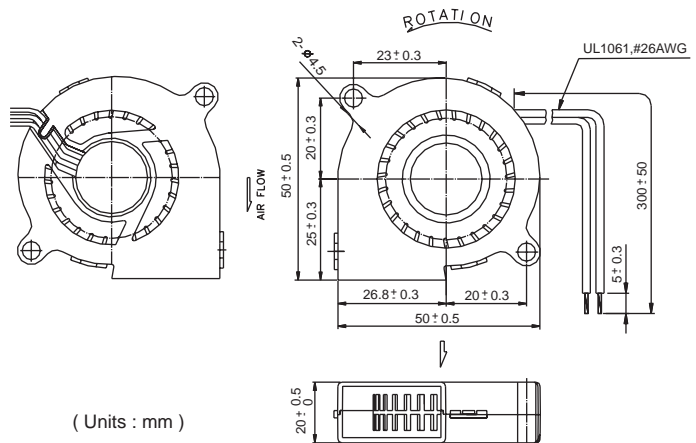
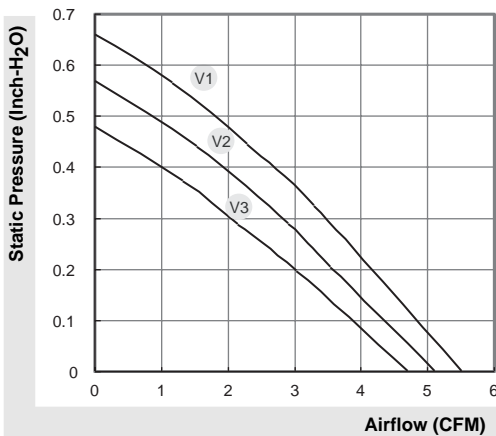

*All model could be customized on voltage or any other requirements to fit your need.

*Specifications subject to change without notice. Please Visit SUNON web site at <http://www.sunon.com> for update information.

60x60x15 mm

SUNON

MagLev Green Motor Blower

3.5~5.2 CFM



Model	P/N	Bearing ● VAPO ⊗ 2BALL	Rating Voltage (VDC)	Power Current (AMP)	Power Consumption (WATTS)	Speed (RPM)	Air Flow (CFM)	Static Pressure (Inch-H ₂ O)	Noise (dBA)	Weight (g)
GB1206PHV1-AY	GN	●	12	0.11	1.3	4800	5.2	0.44	40.5	45
GB1206PHV2-AY	GN	●	12	0.07	0.8	4200	4.7	0.32	36.0	45
GB1206PHV3-AY	GN	●	12	0.04	0.5	3200	3.5	0.18	29.0	45

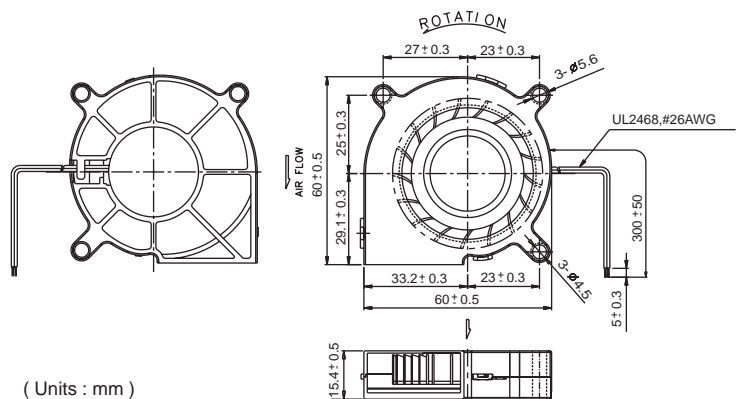
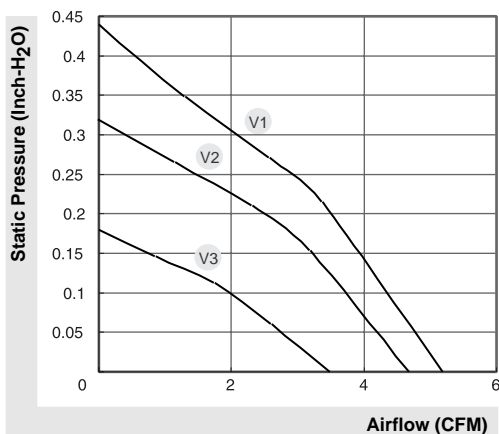

*All model could be customized on voltage or any other requirements to fit your need.

*Specifications subject to change without notice. Please Visit SUNON web site at <http://www.sunon.com> for update information.

Power Motor Blower

7.5~13.6 CFM



Model	P/N	Bearing ● VAPO ⊕ 2BALL	Rating Voltage (VDC)	Power Current (AMP)	Power Consumption (WATTS)	Speed (RPM)	Air Flow (CFM)	Static Pressure (Inch-H ₂ O)	Noise (dBA)	Weight (g)
PMB1275PNB1-AY	(2).GN	⊕	12	0.30	3.6	3400	13.6	0.60	43.5	86.5
PMB1275PNB2-AY	(2).GN	⊕	12	0.23	2.8	3000	12.3	0.48	40.5	86.5
PMB1275PNB3-AY	(2).GN	⊕	12	0.13	1.6	2400	9.6	0.27	33.9	86.5
PMB1275PNB4-AY	(2).GN	⊕	12	0.08	1.0	1900	7.5	0.15	28.0	86.5
PMB2475PNB1-AY	(2).GN	⊕	24	0.17	4.1	3400	13.6	0.60	43.5	86.5
PMB2475PNB2-AY	(2).GN	⊕	24	0.14	3.4	3000	12.3	0.48	40.5	86.5
PMB2475PNB3-AY	(2).GN	⊕	24	0.08	1.9	2400	9.6	0.27	33.9	86.5
PMB2475PNB4-AY	(2).GN	⊕	24	0.05	1.2	1900	7.5	0.15	28.0	86.5

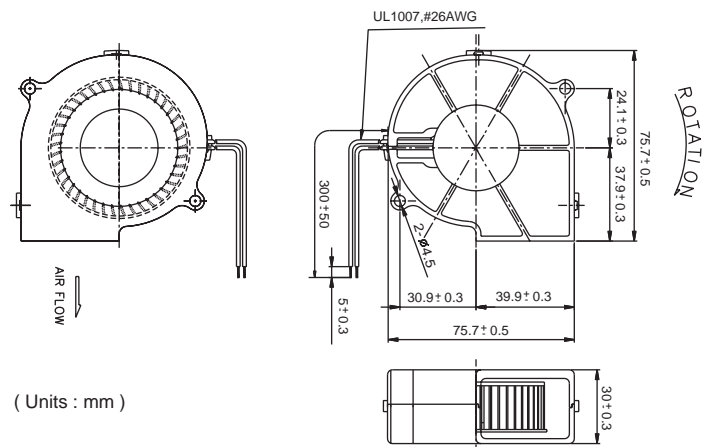
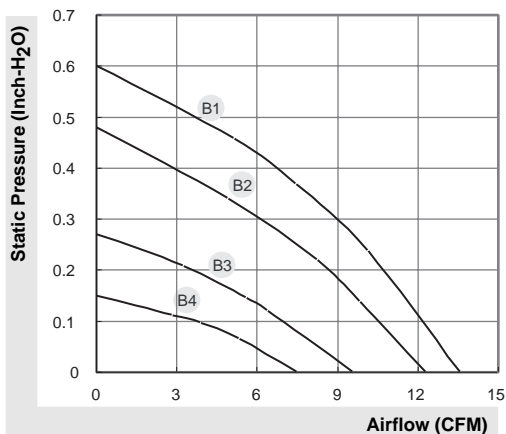

*All model could be customized on voltage or any other requirements to fit your need.

*Specifications subject to change without notice. Please Visit SUNON web site at <http://www.sunon.com> for update information.

97x94x33 mm

SUNON

Power Motor Blower

22.4~30.5 CFM



Model	P/N	Bearing ● VAPO ⊕ 2BALL	Rating Voltage (VDC)	Power Current (AMP)	Power Consumption (WATTS)	Speed (RPM)	Air Flow (CFM)	Static Pressure (Inch-H ₂ O)	Noise (dBA)	Weight (g)
PMB1297PYB1-AY	(2).GN	⊕	12	0.72	8.6	3600	30.5	0.92	55.8	185
PMB1297PYB2-AY	(2).GN	⊕	12	0.56	6.7	3200	26.6	0.65	53.1	185
PMB1297PYB3-AY	(2).GN	⊕	12	0.30	3.6	2700	22.4	0.43	50.0	185
PMB2497PYB1-AY	(2).GN	⊕	24	0.39	9.4	3600	30.5	0.92	55.8	185
PMB2497PYB2-AY	(2).GN	⊕	24	0.25	6.0	3200	26.6	0.65	53.1	185
PMB2497PYB3-AY	(2).GN	⊕	24	0.16	3.8	2700	22.4	0.43	50.0	185
PMB4897PYB1-AY	(2).GN	⊕	48	0.17	8.2	3600	30.5	0.92	55.8	185
PMB4897PYB2-AY	(2).GN	⊕	48	0.13	6.2	3200	26.6	0.65	53.1	185
PMB4897PYB3-AY	(2).GN	⊕	48	0.09	4.3	2700	22.4	0.43	50.0	185

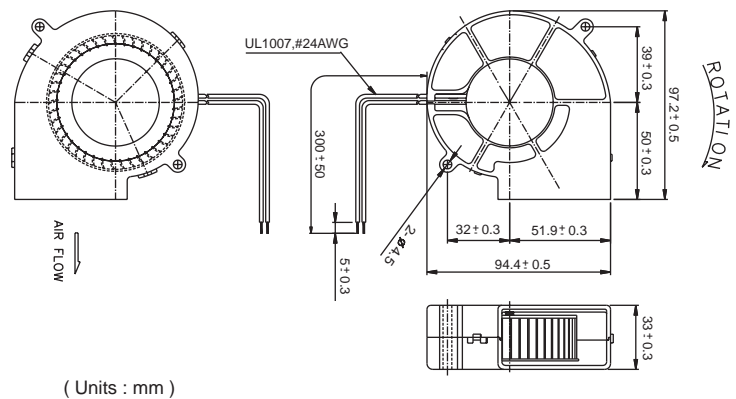
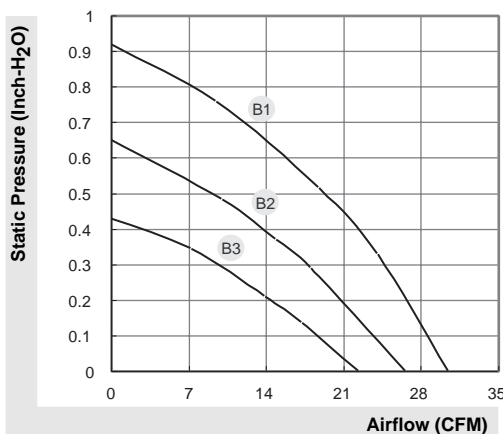

*All model could be customized on voltage or any other requirements to fit your need.

*Specifications subject to change without notice. Please Visit SUNON web site at <http://www.sunon.com> for update information.

Power Motor Blower

31.4~35.9 CFM



Model	P/N	Bearing ● VAPO ○ 2BALL	Rating Voltage (VDC)	Power Current (AMP)	Power Consumption (WATTS)	Speed (RPM)	Air Flow (CFM)	Static Pressure (Inch-H ₂ O)	Noise (dBA)	Weight (g)
PMB1212PLB2-A	(2).GN	○	12	0.82	9.8	2500	35.9	0.89	53.8	250
PMB1212PLB3-A	(2).GN	○	12	0.45	5.4	2100	31.4	0.64	49.6	250
PMB2412PLB2-A	(2).GN	○	24	0.38	9.1	2500	35.9	0.89	53.8	250
PMB2412PLB3-A	(2).GN	○	24	0.24	5.8	2100	31.4	0.64	49.6	250
PMB4812PLB3-A	(2).GN	○	48	0.12	5.8	2100	31.4	0.64	49.6	250

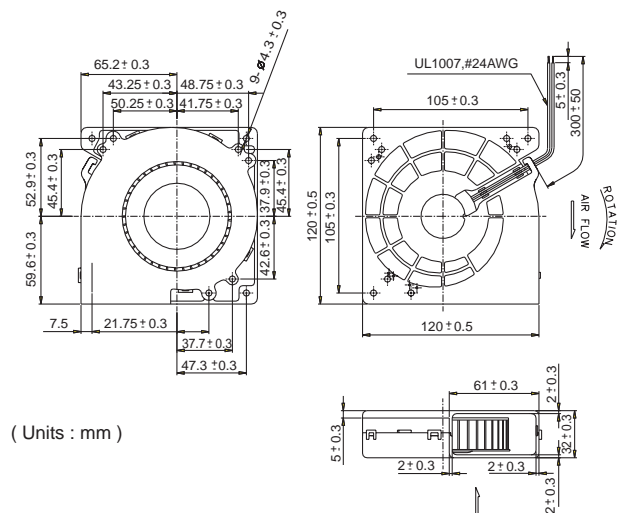
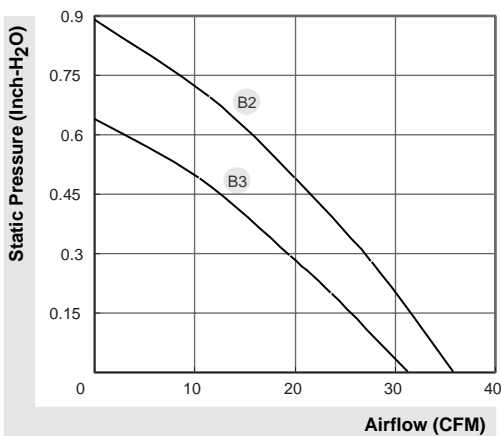

*All model could be customized on voltage or any other requirements to fit your need.

*Specifications subject to change without notice. Please Visit SUNON web site at <http://www.sunon.com> for update information.