

REV	DATE	ECN NUMBER	ECR COMMENT
003	01 Feb 2018	C03835	Add op temp
003	01 Feb 2018	C03835	Add op temp

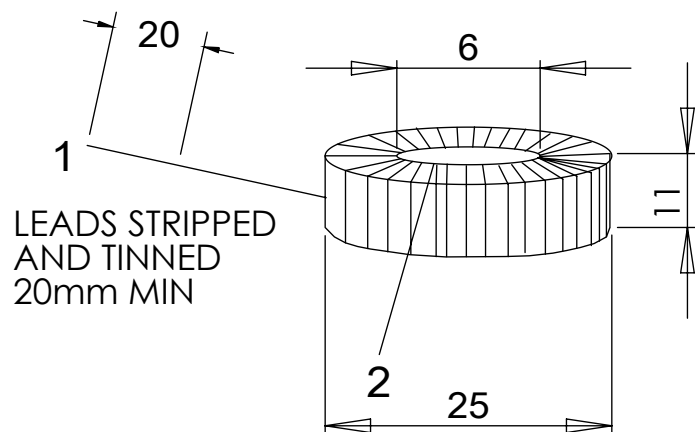

Lead Lengths 40mm +5/-0mm



TOR	
PART No	T80-26 AL 46
SIZE (OD/ID/Ht)	20.2/12.6/6.35
COATING	UL94V-0
MATERIAL	IRON POWDER
Cu Wire	
PART No	COP229 weight 9g
SIZE (Dia)	0.4mm
COATING	SOL 2
Winding	
No Turns	295
No Layers	CONTINUOUS
No Strands	ONE
Direction	AS PER SKETCH
Operating Temp	-40°C/+125°C

TEST	Nom	Tolerance	Min	Max
Inductance (mH)	4.0	+/-20%	3.2	4.8
Res (ohm)	0.9	+/-15%	0.76	1.04
Hi Pot (Vac)	N/A			