

EVALUATION KIT MANUAL
FOLLOWS DATA SHEET

MAXIM

Regulated 5V Charge-Pump DC-DC Converter

MAX619

General Description

The MAX619 step-up charge-pump DC-DC converter delivers a regulated 5V $\pm 4\%$ output at 50mA over temperature. The input voltage range is 2V to 3.6V (two battery cells).

The complete MAX619 circuit fits into less than 0.1in² of board space because it requires only four external capacitors: two 0.22 μ F flying capacitors, and 10 μ F capacitors at the input and output.

Low operating supply current (150 μ A max) and low shutdown supply current (1 μ A max) make this device ideal for small, portable, and battery-powered applications. When shut down, the load is disconnected from the input.

The MAX619 is available in 8-pin DIP and SO packages.

Applications

- Two Battery Cells to 5V Conversion
- Local 3V-to-5V Conversion
- Portable Instruments & Handy-Terminals
- Battery-Powered Microprocessor-Based Systems
- 5V Flash Memory Programmer
- Minimum Component DC-DC Converters
- Remote Data-Acquisition Systems
- Compact 5V Op-Amp Supply
- Regulated 5V Supply from Lithium Backup Battery
- Switching Drive Voltage for MOSFETs in Low-Voltage Systems

Pin Configuration

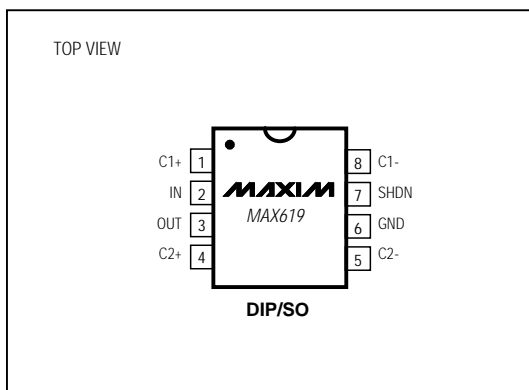

Features

- ◆ **Regulated 5V $\pm 4\%$ Charge Pump**
- ◆ **Output Current Guaranteed over Temperature**
20mA ($V_{IN} \geq 2V$)
50mA ($V_{IN} \geq 3V$)
- ◆ **2V to 3.6V Input Range**
- ◆ **No Inductors; Very Low EMI Noise**
- ◆ **Ultra-Small Application Circuit (0.1in²)**
- ◆ **Uses Small, Inexpensive Capacitors**
- ◆ **500kHz Internal Oscillator**
- ◆ **Logic-Controlled 1 μ A Max Shutdown Supply Current**
- ◆ **Shutdown Disconnects Load from Input**
- ◆ **8-Pin DIP and SO Packages**

Ordering Information

PART	TEMP. RANGE	PIN-PACKAGE
MAX619CPA	0°C to +70°C	8 Plastic DIP
MAX619CSA	0°C to +70°C	8 SO
MAX619C/D	0°C to +70°C	Dice*
MAX619EPA	-40°C to +85°C	8 Plastic DIP
MAX619ESA	-40°C to +85°C	8 SO
MAX619MJA	-55°C to +125°C	8 CERDIP

* Dice are specified at $T_A = +25^\circ\text{C}$.

Typical Operating Circuit

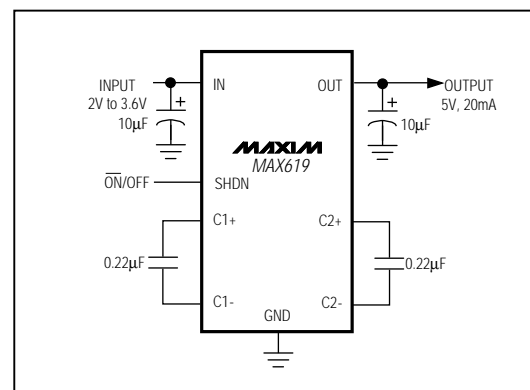

MAXIM

Maxim Integrated Products 1

For free samples & the latest literature: <http://www.maxim-ic.com>, or phone 1-800-998-8800

Regulated 5V Charge-Pump DC-DC Converter

MAX619

ABSOLUTE MAXIMUM RATINGS

V _{IN} to GND	-0.3V to +5.5V
V _{OUT} to GND	-0.3V to +5.5V
SHDN to GND	-0.3V to (V _{IN} + 0.3V)
I _{OUT} Continuous (Note 1)	120mA
Continuous Power Dissipation (T _A = +70°C)	
Plastic DIP (derate 9.09mW/°C above +70°C)	727mW
SO (derate 5.88mW/°C above +70°C)	471mW
CERDIP (derate 8.00mW/°C above +70°C)	640mW

Operating Temperature Ranges

MAX619C	0°C to +70°C
MAX619E	-40°C to +85°C
MAX619MJA	-55°C to +125°C
Storage Temperature Range	-65°C to +165°C
Lead Temperature (soldering, 10sec)	+300°C

Note 1: The MAX619 is not short-circuit protected.

Stresses beyond those listed under "Absolute Maximum Ratings" may cause permanent damage to the device. These are stress ratings only, and functional operation of the device at these or any other conditions beyond those indicated in the operational sections of the specifications is not implied. Exposure to absolute maximum rating conditions for extended periods may affect device reliability.

ELECTRICAL CHARACTERISTICS

(V_{IN} = 2V to 3.6V, C1 = C2 = 0.22μF, C3 = C4 = 10μF, T_A = T_{MIN} to T_{MAX}, unless otherwise noted. Typical values are at T_A = +25°C.)

PARAMETER	SYMBOL	CONDITIONS	MIN	TYP	MAX	UNITS	
Input Voltage	V _{IN}		2		3.6	V	
Output Voltage	V _{OUT}	2.0V ≤ V _{IN} ≤ 3.6V, 0mA ≤ I _{OUT} ≤ 20mA	4.8	5.0	5.2	V	
		3.0V ≤ V _{IN} ≤ 3.6V, 0mA ≤ I _{OUT} ≤ 50mA, MAX619C					
		3.0V ≤ V _{IN} ≤ 3.6V, 0mA ≤ I _{OUT} ≤ 45mA, MAX619E					
		3.0V ≤ V _{IN} ≤ 3.6V, 0mA ≤ I _{OUT} ≤ 40mA, MAX619M					
Output Ripple	V _{RIPPLE}	No load to full load		100		mV	
No-Load Supply Current	I _{IN}	2V ≤ V _{IN} ≤ 3.6V, I _{OUT} = 0mA		75	170	μA	
Shutdown Supply Current		2V ≤ V _{IN} ≤ 3.6V, I _{OUT} = 0mA, V _{SHDN} = V _{IN}	MAX619C/E		0.02	1	μA
			MAX619M			10	
Efficiency	Eff	V _{IN} = 3V, I _{OUT} = 20mA		82		%	
		V _{IN} = 3V, I _{OUT} = 30mA		82			
		V _{IN} = 2V, I _{OUT} = 20mA		80			
Switching Frequency		At full load		500		kHz	
SHDN Input Threshold	V _{IH}		0.7 × V _{IN}			V	
	V _{IL}				0.4		
SHDN Input Current	I _{IH}	V _{SHDN} = V _{IN}	MAX619C/E		±1	μA	
			MAX619M		±10		

Regulated 5V Charge-Pump DC-DC Converter

Typical Operating Characteristics

(T_A = +25°C, unless otherwise noted.)

MAX619

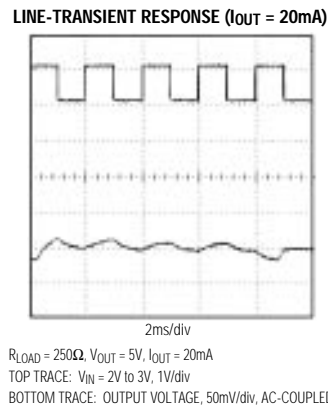
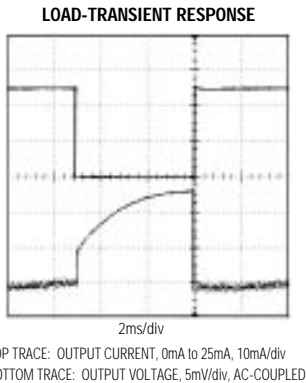
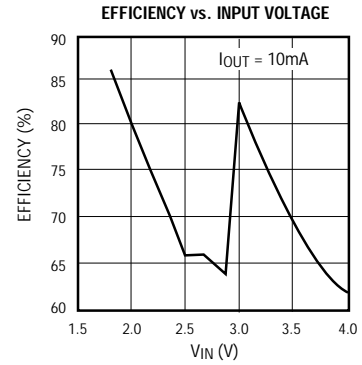
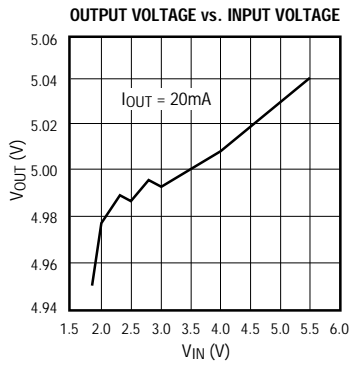
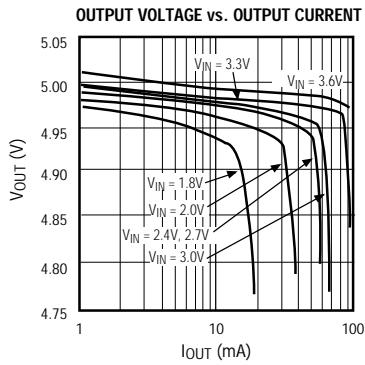
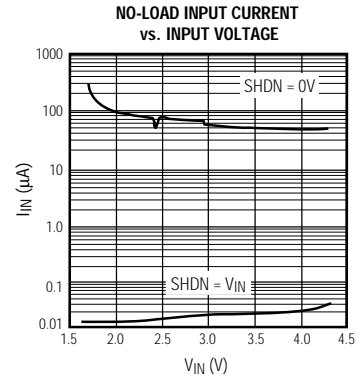
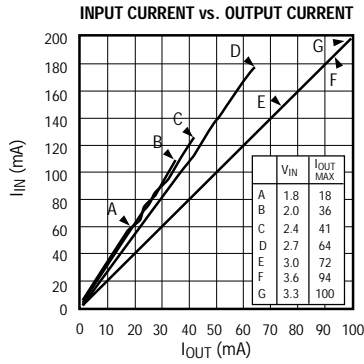
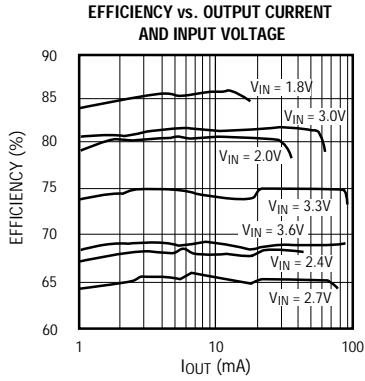

Regulated 5V Charge-Pump DC-DC Converter

Pin Description

PIN	NAME	FUNCTION
1	C1+	Positive Terminal for C1
2	IN	Input Supply Voltage
3	OUT	+5V Output Voltage. $V_{OUT} = 0V$ when in shutdown mode.
4	C2+	Positive Terminal for C2
5	C2-	Negative Terminal for C2
6	GND	Ground
7	SHDN	Active-High CMOS Logic-Level Shutdown Input
8	C1-	Negative Terminal for C1

Detailed Description

Operating Principle

The MAX619 provides a regulated 5V output from a 2V to 3.6V (two battery cells) input. Internal charge pumps and external capacitors generate the 5V output, eliminating the need for inductors. The output voltage is regulated to $5V \pm 4\%$ by a pulse-skipping controller that turns on the charge pump when the output voltage begins to droop.

To maintain the greatest efficiency over the entire input voltage range, the MAX619's internal charge pump operates as a voltage doubler when V_{IN} ranges from 3.0V to 3.6V, and as a voltage tripler when V_{IN} ranges from 2.0V to 2.5V. When V_{IN} ranges from 2.5V to 3.0V,

the MAX619 switches between doubler and tripler mode on alternating cycles, making a $2.5 \times V_{IN}$ charge pump. To further enhance efficiency over the input range, an internal comparator selects the higher of V_{IN} or V_{OUT} to run the MAX619's internal circuitry. Efficiency with $V_{IN} = 2V$ and $I_{OUT} = 20mA$ is typically 80%.

Figure 1 shows a detailed block diagram of the MAX619. In tripler mode, when the S1 switches close, the S2 switches open and capacitors C1 and C2 charge up to V_{IN} . On the second half of the cycle, C1 and C2 are connected in series between IN and OUT when the S1 switches open and the S2 switches close, as shown in Figure 1. In doubler mode, only C2 is used.

During one oscillator cycle, energy is transferred from the input to the charge-pump capacitors, and then from the charge-pump capacitors to the output capacitor and load. The number of cycles within a given time frame increases as the load increases or as the input supply voltage decreases. In the limiting case, the charge pumps operate continuously, and the oscillator frequency is nominally 500kHz.

Shutdown Mode

The MAX619 enters low-power shutdown mode when SHDN is a logic high. SHDN is a CMOS-compatible input. In shutdown mode, the charge-pump switching action is halted, OUT is disconnected from IN, and V_{OUT} falls to 0V. Connect SHDN to ground for normal operation. When $V_{IN} = 3.6V$, V_{OUT} typically reaches 5V in 0.5ms under no-load conditions after SHDN goes low.

Regulated 5V Charge-Pump DC-DC Converter

MAX619

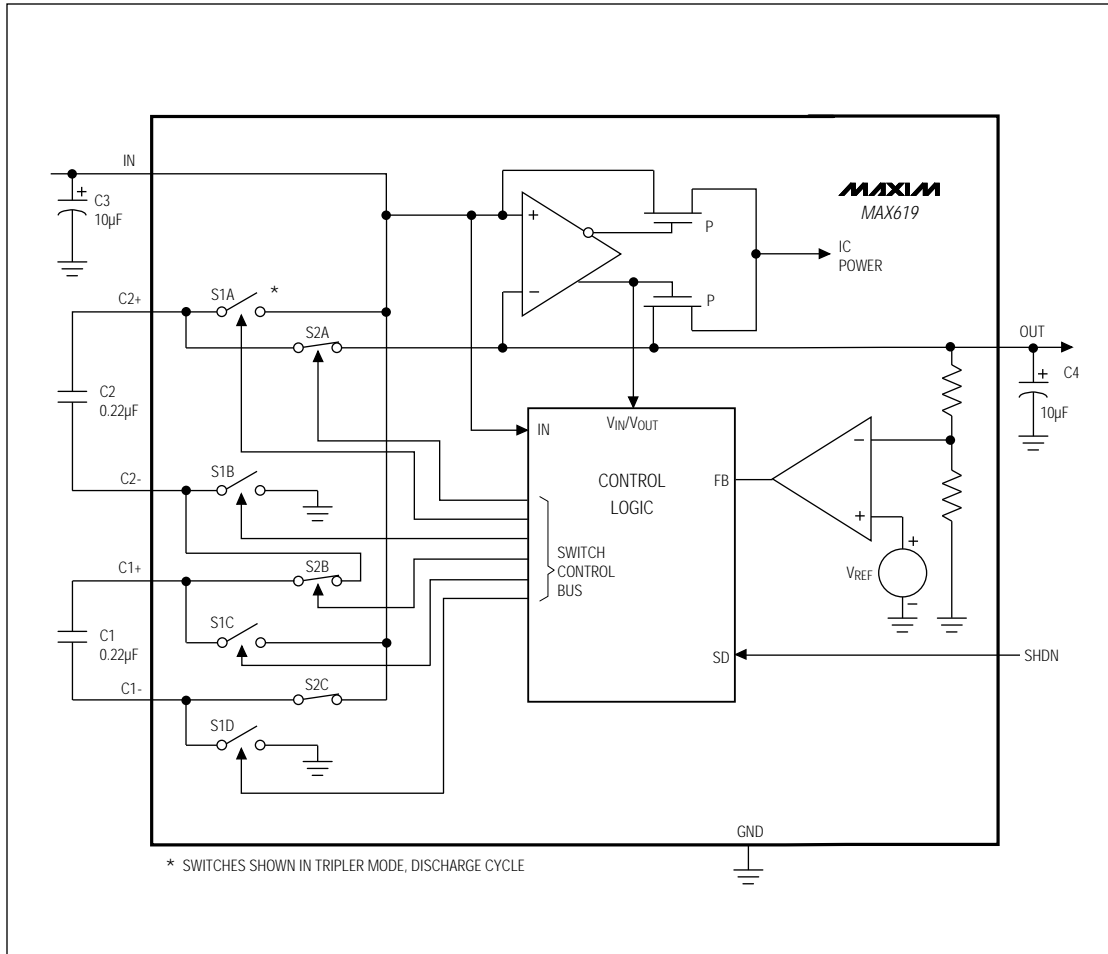

Figure 1. Block Diagram

Regulated 5V Charge-Pump DC-DC Converter

Applications Information

Capacitor Selection

Charge-Pump Capacitors C1 and C2

The values of charge-pump capacitors C1 and C2 are critical to ensure adequate output current and avoid excessive peak currents. Use values in the range of 0.22 μ F to 1.0 μ F. Larger capacitors (up to 50 μ F) can be used, but larger capacitors will increase output ripple. Ceramic or tantalum capacitors are recommended.

Input and Output Capacitors, C3 and C4

The type of input bypass capacitor (C3) and output filter capacitor (C4) used is not critical, but it does affect performance. Tantalums, ceramics, or aluminum electrolytics are suggested. For smallest size, use Sprague 595D106X0010A2 surface-mount capacitors, which measure 3.7mm x 1.8mm (0.146in x 0.072in). For lowest ripple, use large, low effective-series-resistance (ESR) ceramic or tantalum capacitors. For lowest cost, use aluminum electrolytic or tantalum capacitors.

Figure 2 shows the component values for proper operation using minimal board space. The input bypass capacitor (C3) and output filter capacitor (C4) should both be at least 10 μ F when using aluminum electrolytics or Sprague's miniature 595D series of tantalum chip capacitors.

When using ceramic capacitors, the values of C3 and C4 can be reduced to 2 μ F and 1 μ F, respectively. If the input supply source impedance is very low, C3 may not be necessary.

Many capacitors exhibit 40% to 50% variation over temperature. Compensate for capacitor temperature coefficient by selecting a larger nominal value to ensure proper operation over temperature. Table 1 lists capacitor suppliers.

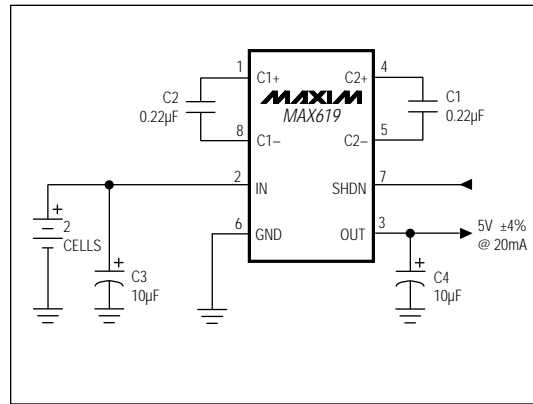

Figure 2. Two-Cell to 5V Application Circuit

Table 1. Capacitor Suppliers

SUPPLIER	PHONE NUMBER	FAX NUMBER	CAPACITOR	CAPACITOR TYPE*
Murata Erie	(814) 237-1431	(814) 238-0490	GRM42-6Z5U10M50	0.1 μ F ceramic (SM)
			GRM42-6Z5U22M50	0.22 μ F ceramic (SM)
			RPI123Z5U105M50V	1.0 μ F ceramic (TH)
			RPE121Z5U104M50V	0.1 μ F ceramic (TH)
Sprague Electric (smallest size)	(603) 224-1961 (207) 327-4140	(603) 224-1430 (207) 324-7223	595D106X0010A2	10 μ F tantalum (SM)

* **Note:** (SM) denotes surface-mount component, (TH) denotes through-hole component.

Regulated 5V Charge-Pump DC-DC Converter

Layout Considerations

The MAX619's high oscillator frequency makes good layout important. A good layout ensures stability and helps maintain the output voltage under heavy loads. For best performance, use very short connections to the capacitors.

Paralleling Devices

Two MAX619s can be placed in parallel to increase output drive capability. The IN, OUT, and GND pins can be paralleled, but C1 and C2 pins cannot. The input bypass capacitor and output filter capacitor are, to some extent, shared when two circuits are paralleled. If the circuits are physically close together, it may be possible to use a single bypass and a single output capacitor, each with twice the value of the single circuit. If the MAX619s cannot be placed close together, use separate bypass and output capacitors. The amount of output ripple observed will determine whether single input bypass and output filter capacitors can be used.

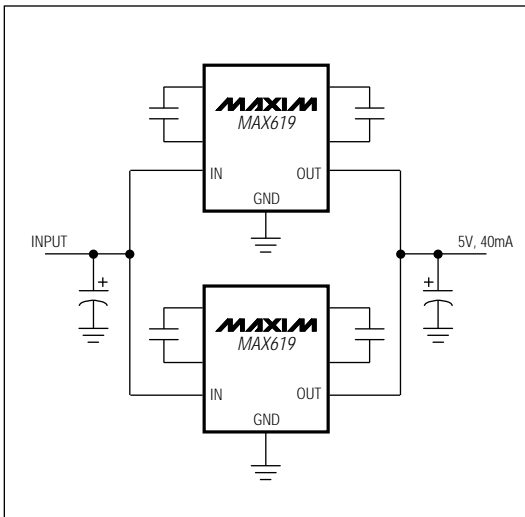
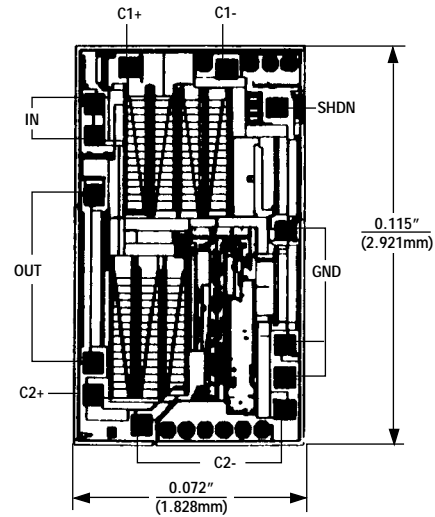

Figure 3. Paralleling Two MAX619s

Chip Topography



TRANSISTOR COUNT: 599;
SUBSTRATE CONNECTED TO GND.

MAX619

This datasheet has been downloaded from:

www.DatasheetCatalog.com

Datasheets for electronic components.