

## Trench gate field-stop IGBT, HB series 650 V, 40 A high speed

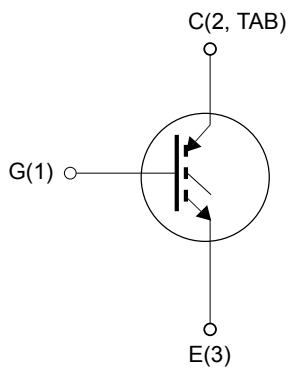
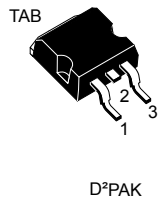

### Features

- Maximum junction temperature:  $T_J = 175\text{ °C}$
- High speed switching series
- Minimized tail current
- Low saturation voltage:  $V_{CE(sat)} = 1.6\text{ V (typ.) @ } I_C = 40\text{ A}$
- Tight parameter distribution
- Safe paralleling
- Low thermal resistance

### Applications

- Photovoltaic inverters
- High frequency converters

### Description

This device is an IGBT developed using an advanced proprietary trench gate field-stop structure. The device is part of the new HB series of IGBTs, which represents an optimum compromise between conduction and switching loss to maximize the efficiency of any frequency converter. Furthermore, the slightly positive  $V_{CE(sat)}$  temperature coefficient and very tight parameter distribution result in safer paralleling operation.

#### Product status link

[STGB40H65FB](#)

#### Product summary

Order code	STGB40H65FB
Marking	GB40H65FB
Package	D <sup>2</sup> PAK
Packing	Tape and reel

# 1 Electrical ratings

**Table 1. Absolute maximum ratings**

Symbol	Parameter	Value	Unit
$V_{CES}$	Collector-emitter voltage ( $V_{GE} = 0$ V)	650	V
$I_C$	Continuous collector current at $T_C = 25$ °C	80	A
	Continuous collector current at $T_C = 100$ °C	40	
$I_{CP}^{(1)}$	Pulsed collector current	160	A
$V_{GE}$	Gate-emitter voltage	$\pm 20$	V
$P_{TOT}$	Total power dissipation at $T_C = 25$ °C	283	W
$T_{STG}$	Storage temperature range	- 55 to 150	°C
$T_J$	Operating junction temperature range	- 55 to 175	

1. Pulse width limited by maximum junction temperature.

**Table 2. Thermal data**

Symbol	Parameter	Value	Unit
$R_{thJC}$	Thermal resistance junction-case	0.53	°C/W
$R_{thJA}$	Thermal resistance junction-ambient	62.5	

## 2 Electrical characteristics

$T_C = 25\text{ °C}$  unless otherwise specified

**Table 3. Static characteristics**

Symbol	Parameter	Test conditions	Min.	Typ.	Max.	Unit
$V_{(BR)CES}$	Collector-emitter breakdown voltage	$V_{GE} = 0\text{ V}, I_C = 2\text{ mA}$	650			V
$V_{CE(sat)}$	Collector-emitter saturation voltage	$V_{GE} = 15\text{ V}, I_C = 40\text{ A}$		1.6	2	V
		$V_{GE} = 15\text{ V}, I_C = 40\text{ A}, T_J = 125\text{ °C}$		1.7		
		$V_{GE} = 15\text{ V}, I_C = 40\text{ A}, T_J = 175\text{ °C}$		1.8		
$V_{GE(th)}$	Gate threshold voltage	$V_{CE} = V_{GE}, I_C = 1\text{ mA}$	5	6	7	V
$I_{CES}$	Collector cut-off current	$V_{GE} = 0\text{ V}, V_{CE} = 650\text{ V}$			25	$\mu\text{A}$
$I_{GES}$	Gate-emitter leakage current	$V_{CE} = 0\text{ V}, V_{GE} = \pm 20\text{ V}$			$\pm 250$	nA

**Table 4. Dynamic characteristics**

Symbol	Parameter	Test conditions	Min.	Typ.	Max.	Unit
$C_{ies}$	Input capacitance	$V_{CE} = 25\text{ V}, f = 1\text{ MHz}, V_{GE} = 0\text{ V}$	-	5412	-	$\mu\text{F}$
$C_{oes}$	Output capacitance		-	198	-	
$C_{res}$	Reverse transfer capacitance		-	107	-	
$Q_g$	Total gate charge	$V_{CC} = 520\text{ V}, I_C = 40\text{ A}, V_{GE} = 0\text{ to }15\text{ V}$ (see <a href="#">Figure 22. Gate charge test circuit</a> )	-	210	-	nC
$Q_{ge}$	Gate-emitter charge		-	39	-	
$Q_{gc}$	Gate-collector charge		-	82	-	

**Table 5. Switching characteristics (inductive load)**

Symbol	Parameter	Test conditions	Min.	Typ.	Max.	Unit
$t_{d(on)}$	Turn-on delay time	$V_{CE} = 400\text{ V}$ , $I_C = 40\text{ A}$ , $V_{GE} = 15\text{ V}$ , $R_G = 5\ \Omega$ (see <a href="#">Figure 21. Test circuit for inductive load switching</a> )	-	40	-	ns
$t_r$	Current rise time		-	13	-	
$(di/dt)_{on}$	Turn-on current slope		-	2413	-	A/ $\mu$ s
$t_{d(off)}$	Turn-off-delay time		-	142	-	ns
$t_f$	Current fall time		-	27	-	
$E_{on}^{(1)}$	Turn-on switching energy		-	498	-	$\mu$ J
$E_{off}^{(2)}$	Turn-off switching energy		-	363	-	
$E_{ts}$	Total switching energy		-	861	-	
$t_{d(on)}$	Turn-on delay time		$V_{CE} = 400\text{ V}$ , $I_C = 40\text{ A}$ , $V_{GE} = 15\text{ V}$ , $R_G = 5\ \Omega$ , $T_J = 175\text{ }^\circ\text{C}$ (see <a href="#">Figure 21. Test circuit for inductive load switching</a> )	-	38	-
$t_r$	Current rise time	-		14	-	
$(di/dt)_{on}$	Turn-on current slope	-		2186	-	A/ $\mu$ s
$t_{d(off)}$	Turn-off-delay time	-		141	-	ns
$t_f$	Current fall time	-		61	-	
$E_{on}^{(1)}$	Turn-on switching energy	-		1417	-	$\mu$ J
$E_{off}^{(2)}$	Turn-off switching energy	-		764	-	
$E_{ts}$	Total switching energy	-		2181	-	

1. Including the reverse recovery of the external diode.
2. Including the tail of the collector current.

## 2.1 Electrical characteristics (curves)

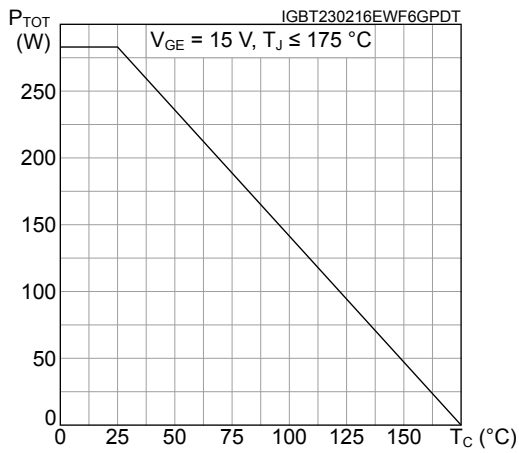
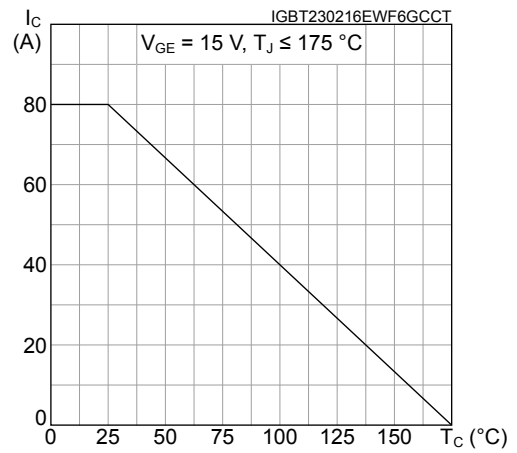
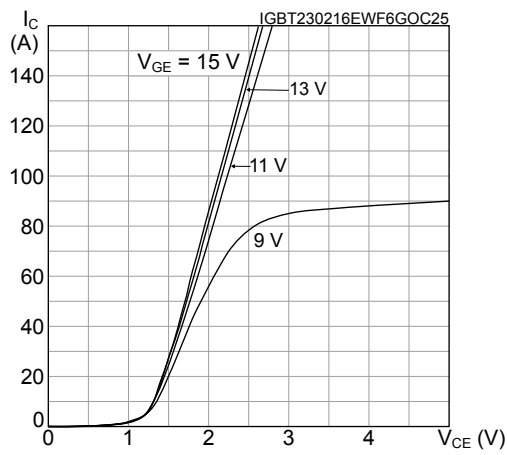
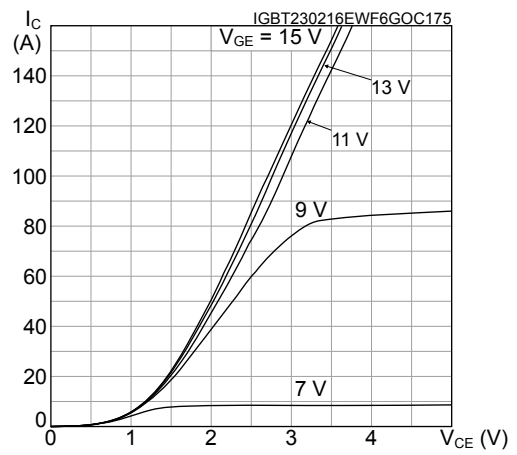
**Figure 1. Power dissipation vs. case temperature**

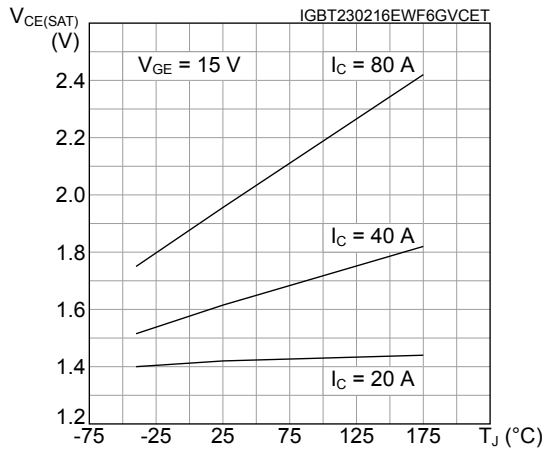
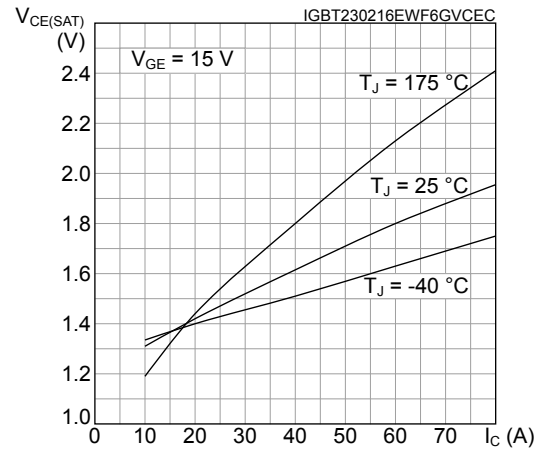
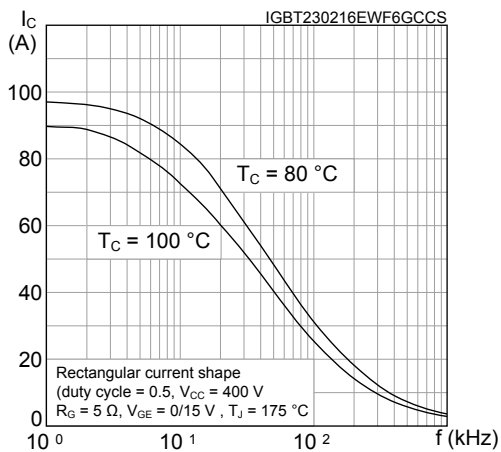
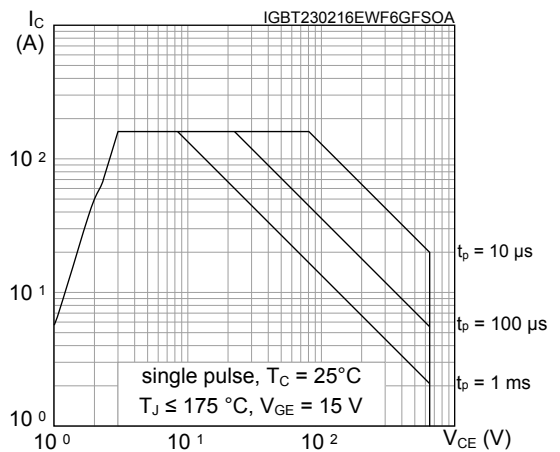
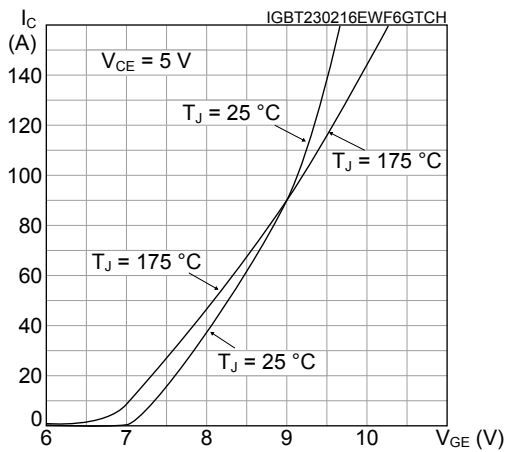
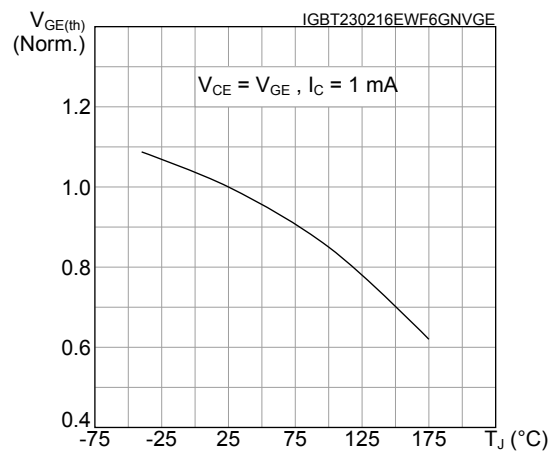
**Figure 2. Collector current vs. case temperature**

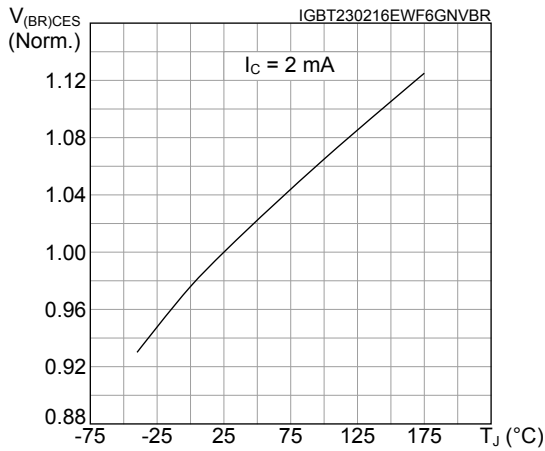
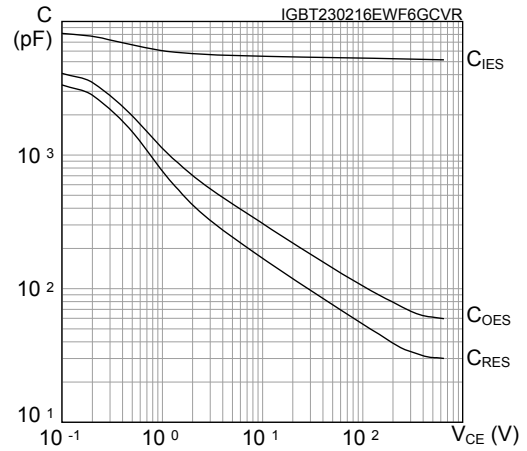
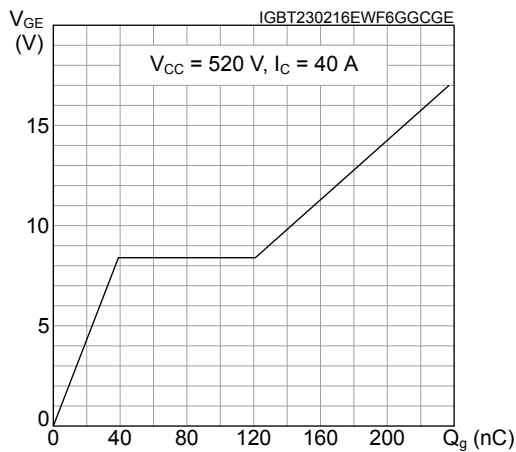
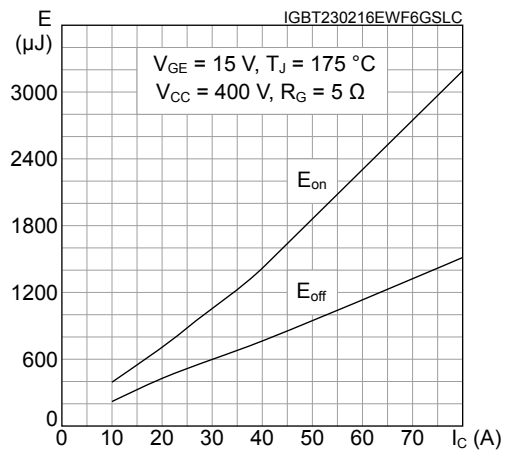
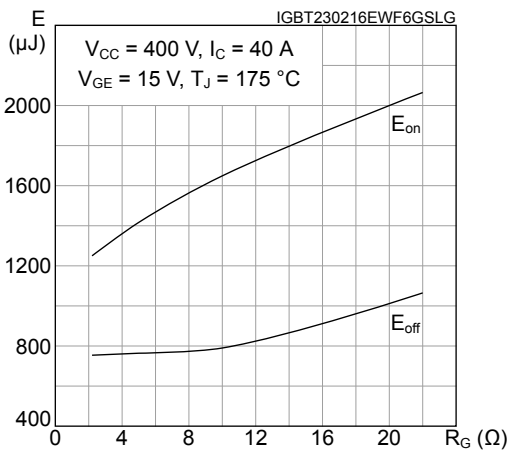
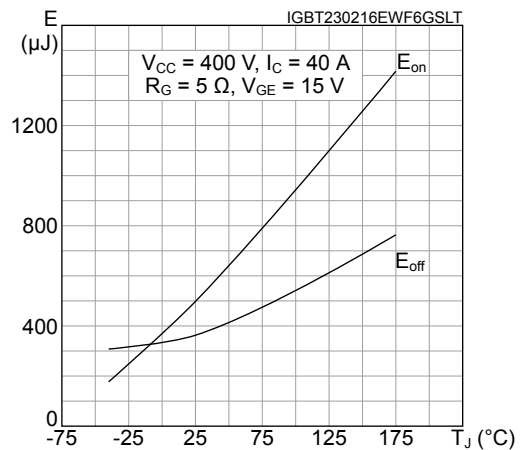
**Figure 3. Output characteristics ( $T_J = 25\text{ }^\circ\text{C}$ )**

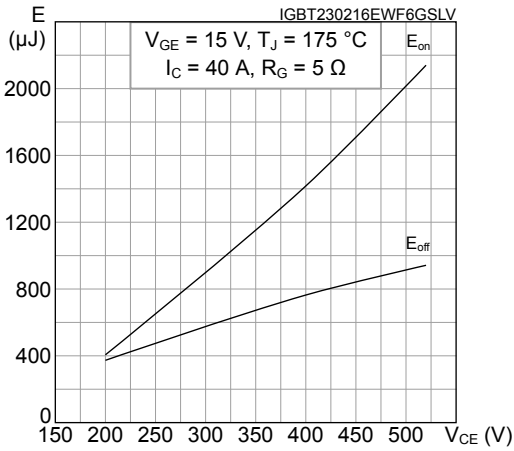
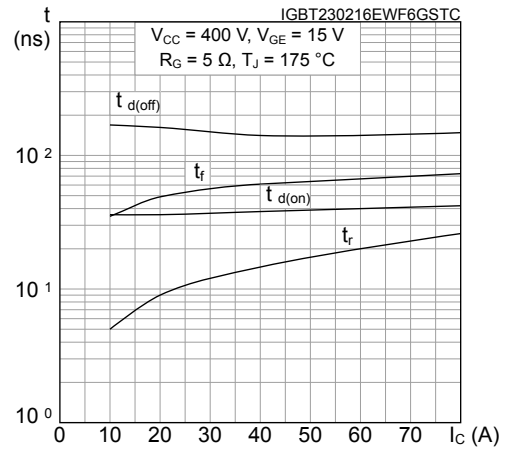
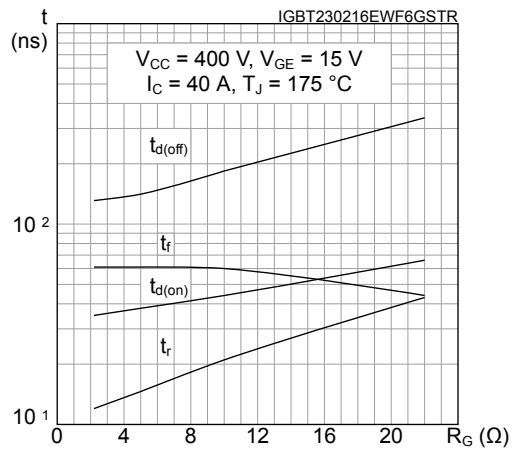
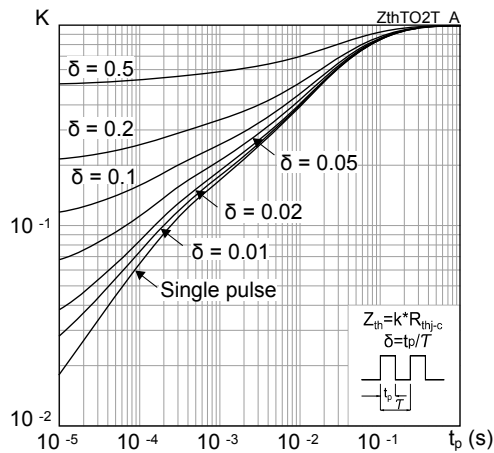
**Figure 4. Output characteristics ( $T_J = 175\text{ }^\circ\text{C}$ )**

**Figure 5.  $V_{CE(sat)}$  vs. junction temperature**

**Figure 6.  $V_{CE(sat)}$  vs. collector current**

**Figure 7. Collector current vs. switching frequency**

**Figure 8. Forward bias safe operating area**

**Figure 9. Transfer characteristics**

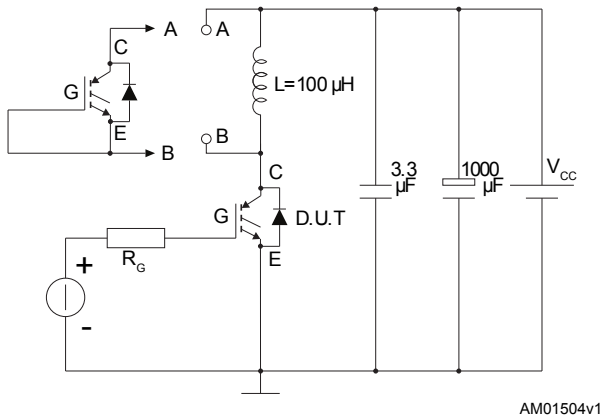
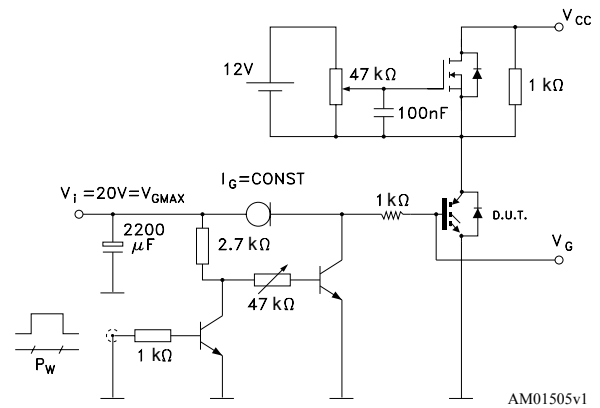
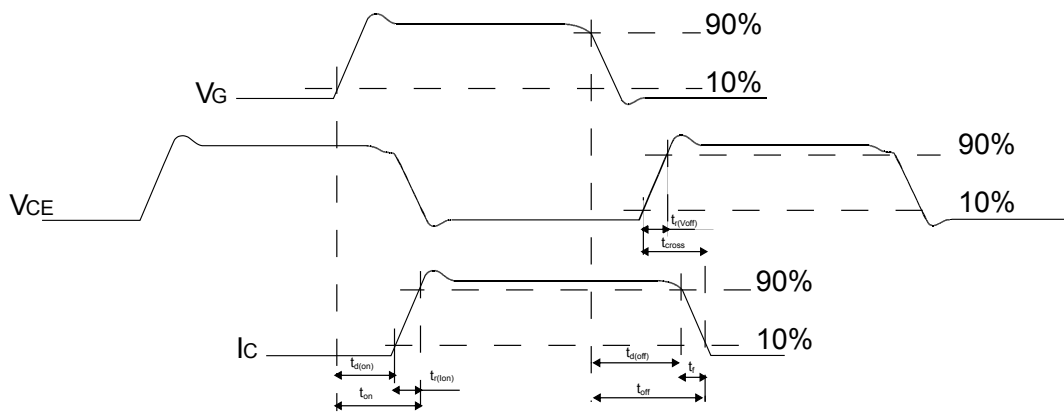
**Figure 10. Normalized  $V_{GE(th)}$  vs. junction temperature**

**Figure 11. Normalized  $V_{(BR)CES}$  vs. junction temperature**

**Figure 12. Capacitance variations**

**Figure 13. Gate charge vs. gate-emitter voltage**

**Figure 14. Switching energy vs. collector current**

**Figure 15. Switching energy vs. gate resistance**

**Figure 16. Switching energy vs. temperature**

**Figure 17. Switching energy vs. collector emitter voltage**

**Figure 18. Switching times vs. collector current**

**Figure 19. Switching times vs. gate resistance**

**Figure 20. Thermal impedance**



### 3 Test circuits

**Figure 21. Test circuit for inductive load switching**

**Figure 22. Gate charge test circuit**

**Figure 23. Switching waveform**

## 4 Package information

---

In order to meet environmental requirements, ST offers these devices in different grades of **ECOPACK®** packages, depending on their level of environmental compliance. ECOPACK® specifications, grade definitions and product status are available at: [www.st.com](http://www.st.com). ECOPACK® is an ST trademark.

### 4.1 D<sup>2</sup>PAK (TO-263) type A2 package information

Figure 24. D<sup>2</sup>PAK (TO-263) type A2 package outline

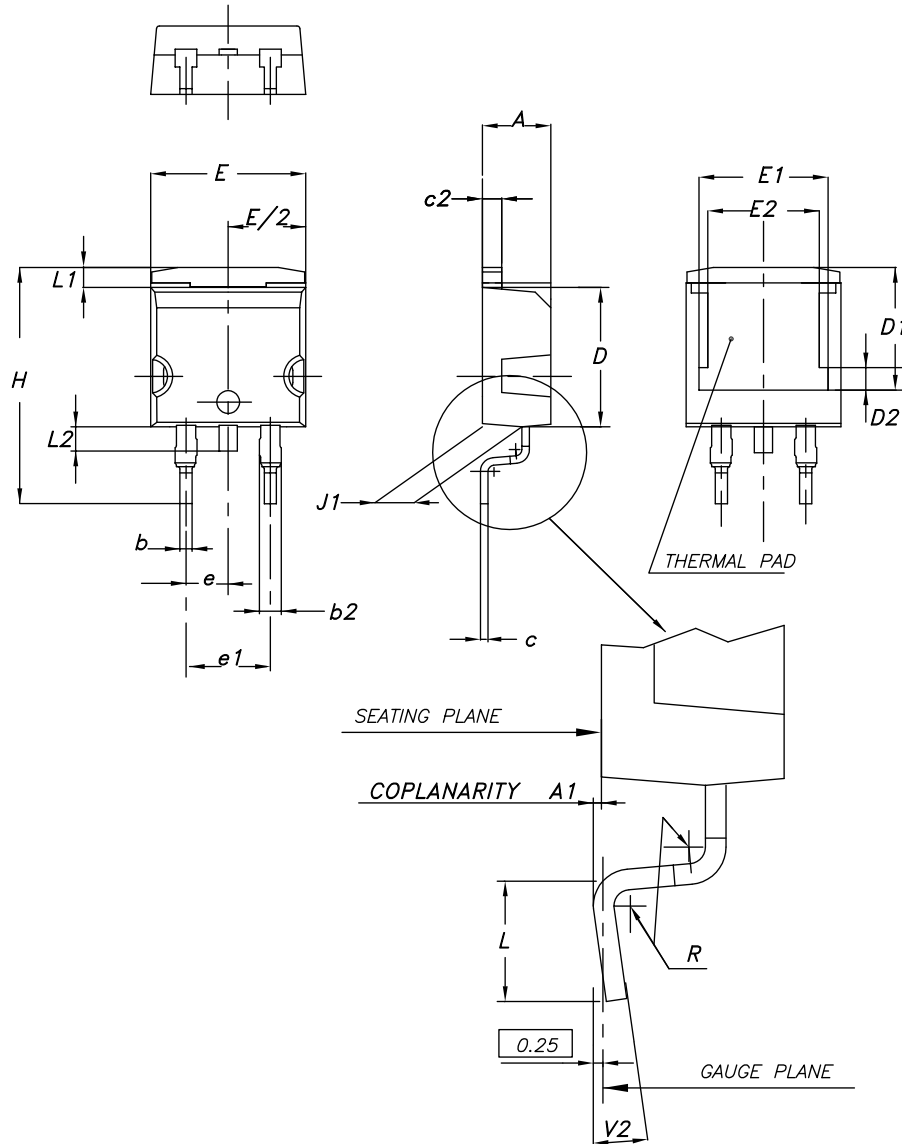

0079457\_A2\_25

**Table 6. D<sup>2</sup>PAK (TO-263) type A2 package mechanical data**

Dim.	mm		
	Min.	Typ.	Max.
A	4.40		4.60
A1	0.03		0.23
b	0.70		0.93
b2	1.14		1.70
c	0.45		0.60
c2	1.23		1.36
D	8.95		9.35
D1	7.50	7.75	8.00
D2	1.10	1.30	1.50
E	10.00		10.40
E1	8.70	8.90	9.10
E2	7.30	7.50	7.70
e		2.54	
e1	4.88		5.28
H	15.00		15.85
J1	2.49		2.69
L	2.29		2.79
L1	1.27		1.40
L2	1.30		1.75
R		0.40	
V2	0°		8°

**Figure 25. D<sup>2</sup>PAK (TO-263) recommended footprint (dimensions are in mm)**

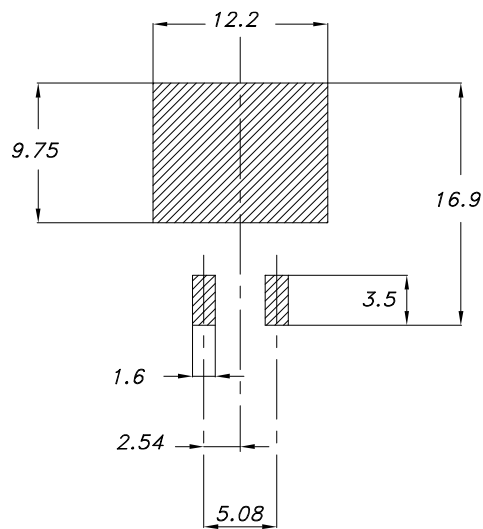

## 4.2 D<sup>2</sup>PAK packing information

Figure 26. D<sup>2</sup>PAK tape outline

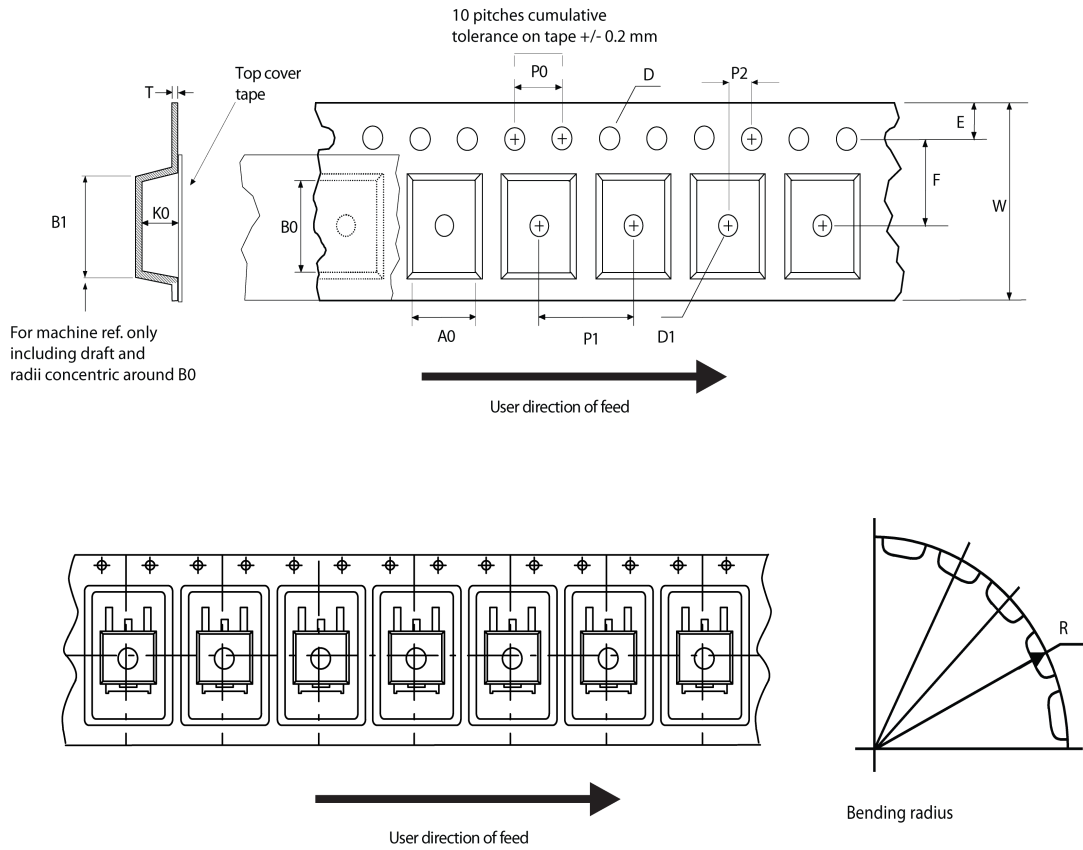

AM08852v1

**Figure 27. D<sup>2</sup>PAK reel outline**

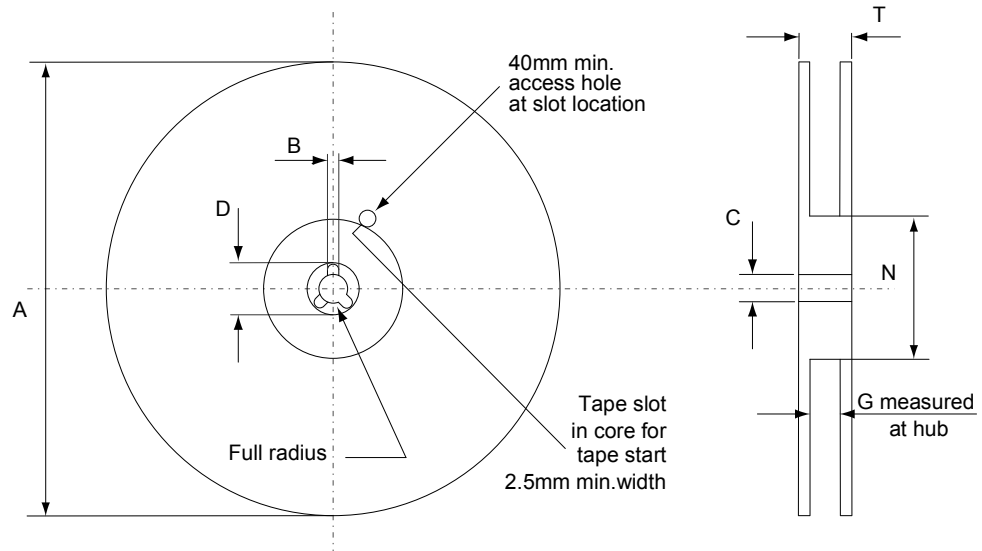

AM06038v1

**Table 7. D<sup>2</sup>PAK tape and reel mechanical data**

Tape			Reel		
Dim.	mm		Dim.	mm	
	Min.	Max.		Min.	Max.
A0	10.5	10.7	A		330
B0	15.7	15.9	B	1.5	
D	1.5	1.6	C	12.8	13.2
D1	1.59	1.61	D	20.2	
E	1.65	1.85	G	24.4	26.4
F	11.4	11.6	N	100	
K0	4.8	5.0	T		30.4
P0	3.9	4.1			
P1	11.9	12.1	Base quantity		1000
P2	1.9	2.1	Bulk quantity		1000
R	50				
T	0.25	0.35			
W	23.7	24.3			

## Revision history

**Table 8. Document revision history**

Date	Revision	Changes
27-Jun-2016	1	Initial release.
13-Feb-2019	2	Updated <a href="#">Section 4.1 D<sup>2</sup>PAK (TO-263) type A2 package information.</a>

## Contents

<b>1</b>	<b>Electrical ratings</b> .....	<b>2</b>
<b>2</b>	<b>Electrical characteristics</b> .....	<b>3</b>
<b>2.1</b>	<b>Electrical characteristics (curves)</b> .....	<b>5</b>
<b>3</b>	<b>Test circuits</b> .....	<b>9</b>
<b>4</b>	<b>Package information</b> .....	<b>10</b>
<b>4.1</b>	<b>D<sup>2</sup>PAK (TO-263) type A2 package information</b> .....	<b>10</b>
<b>4.2</b>	<b>Packing information</b> .....	<b>12</b>
	<b>Revision history</b> .....	<b>15</b>
	<b>Contents</b> .....	<b>16</b>



**IMPORTANT NOTICE – PLEASE READ CAREFULLY**

STMicroelectronics NV and its subsidiaries (“ST”) reserve the right to make changes, corrections, enhancements, modifications, and improvements to ST products and/or to this document at any time without notice. Purchasers should obtain the latest relevant information on ST products before placing orders. ST products are sold pursuant to ST’s terms and conditions of sale in place at the time of order acknowledgement.

Purchasers are solely responsible for the choice, selection, and use of ST products and ST assumes no liability for application assistance or the design of Purchasers’ products.

No license, express or implied, to any intellectual property right is granted by ST herein.

Resale of ST products with provisions different from the information set forth herein shall void any warranty granted by ST for such product.

ST and the ST logo are trademarks of ST. All other product or service names are the property of their respective owners.

Information in this document supersedes and replaces information previously supplied in any prior versions of this document.

© 2019 STMicroelectronics – All rights reserved

# Mouser Electronics

Authorized Distributor

Click to View Pricing, Inventory, Delivery & Lifecycle Information:

[STMicroelectronics:](#)

[STGB40H65FB](#)