

ALUMINUM ELECTROLYTIC CAPACITORS

LNC

Screw Terminal Type, 85°C Smaller-sized
Higher ripple current



- Suited for use in industrial power supplies for inverter circuitry, etc.
- Load life 5000 hours application of ripple current at 85°C.
- Smaller sized / High ripple current than LNX, LNK.
- Coped with loading of high speed charge-discharge.
- Suited for high frequency regenerative voltage for AC servomotor, general inverter.
- Compliant to the RoHS directive (2011/65/EU, (EU)2015/863).

LNX LNK



LNC



Specifications

Item	Performance Characteristics		
Category Temperature Range	- 40 to +85°C		
Rated Voltage Range	350 to 500V		
Rated Capacitance Range	1000 to 22000μF		
Capacitance Tolerance	±20% at 120Hz, 20°C		
Leakage Current	After 5 minutes' application of rated voltage, leakage current is not more than $3\sqrt{CV}$ (μA) or 5 mA, whichever is smaller (at 20°C). [C: Rated Capacitance(μF), V: Voltage (V)]		
Tangent of loss angle (tan δ)	See refer to next page (Measurement frequency: 120Hz at 20°C)		
Stability at Low Temperature	Rated voltage (V)	350 to 500	
	Impedance ratio (max.)	$Z(-40°C) / Z(+20°C)$ 8	
Measurement frequency: 120Hz			
Insulation Resistance	The insulation resistance shall be more than 100MΩ at DC 500V application between terminal and bracket.		
Voltage proof	There is no abnormality during AC 2500V 1 minute's application between terminal and bracket.		
Endurance	The specifications listed at right shall be met when the capacitors are restored to 20°C after D.C. bias plus rated ripple current is applied for 5000 hours at 85°C, the peak voltage shall not exceed the rated voltage.	Capacitance change	Within ±20% of the initial capacitance value
		tan δ	200% or less than the initial specified value
		Leakage current	Less than or equal to the initial specified value
Shelf Life	After storing the capacitors under no load at 85°C for 1000 hours and then performing voltage treatment based on JIS C 5101-4 clause 4.1 at 20°C, they shall meet the requirements listed at right.	Capacitance change	Within ±20% of the initial capacitance value
		tan δ	200% or less than the initial specified value
		Leakage current	Less than or equal to the initial specified value
Endurance of charge-discharge behavior	After an application of charge-discharge voltage for 50million times (charge-discharge voltage difference(ΔV)=rated voltage × 0.3, cycle 3Hz)capacitors shall meet the characteristics requirement listed at right.	Capacitance change	Within ±20% of the initial capacitance value
		tan δ	200% or less than the initial specified value
		Leakage current	Less than or equal to the initial specified value
Marking	Printed with white color letter on black sleeve.		

Drawing

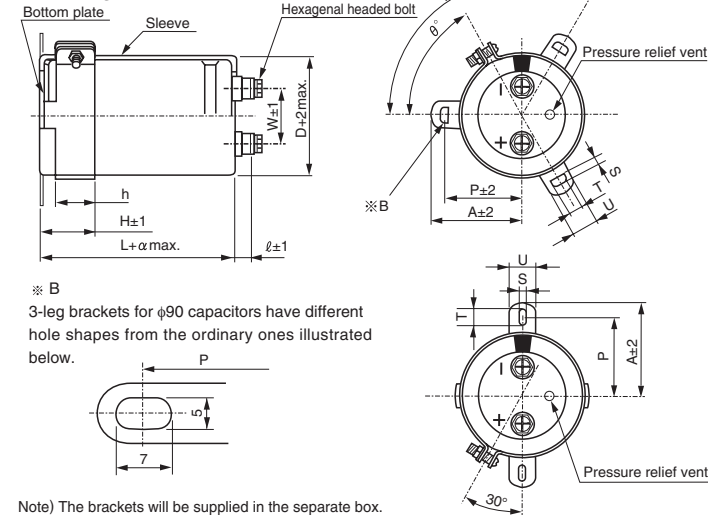

Type numbering system (Example : 400V 10000μF)

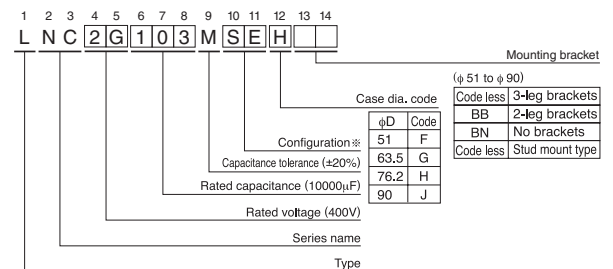

※ Configuration

SE	standard specifications
TE	stud mount type

Please refer to the Guidelines for Aluminum Electrolytic Capacitors for dimensions information.

※ Please contact to us if PVCless products are required.

● Dimension of terminal pitch (W) and length (ℓ) and Nominal dia. of bolt (mm)

φD	W	ℓ	α	Nominal dia. of bolt
51	22.0	6	3	M 5
63.5	28.6	6	3	M 5
76.2	31.8	6	3	M 5
90	31.8	6	3	M 5

About product of stud bolt
 • Nylon nut and nylon washer attachment are shown in the standard specifications.
 (Please refer to the Guidelines for Aluminum Electrolytic Capacitors)
 • It is not attached to the bracket.
 • Field 13 and 14 become blank in Type number system.

● Dimensions of mounting bracket (mm)

Symbol	Leg shape φD	3-Leg			2-Leg				
		51	63.5	76.2	90	51	63.5	76.2	90
P		32.5	38.1	44.5	50.8	33.2	40.5	46.5	53
A		38.5	43	49.2	58.5	40	46.5	53	59
T		7.5	8.0	7.0	8.0	6.0	7.0	6.0	6.0
S		5.0	5.0	5.0	5.0	4.5	4.5	4.5	4.5
U		12	14	14	18	14	14	14	14
θ °		60	60	60	60	30	30	30	30
H		20	25	30	35	25	35	35	35
h		15	20	24	25	15	20	20	20

● Dimension table in next page.

LNC

■ Dimensions

350V(2V)					
Cap. (μF)	Size φD × L(mm)	Rated ripple (Arms)	tan δ	Leakage Current (mA)	Code
1000	51 × 55	8.4	0.20	1.77	LNC2V102MSEF
1200	51 × 60	8.6	0.20	1.94	LNC2V122MSEF
1500	51 × 65	9.3	0.20	2.17	LNC2V152MSEF
1800	51 × 75	10.3	0.20	2.38	LNC2V182MSEF
2200	51 × 85	11.9	0.20	2.63	LNC2V222MSEF
2700	51 × 95	13.3	0.20	2.91	LNC2V272MSEF
	63.5 × 70	13.7	0.20	2.91	LNC2V272MSEG
3300	51 × 115	13.6	0.20	3.22	LNC2V332MSEF
	63.5 × 80	14.0	0.20	3.22	LNC2V332MSEG
3900	63.5 × 85	14.9	0.20	3.50	LNC2V392MSEG
	76.2 × 70	14.3	0.20	3.50	LNC2V392MSEH
4700	63.5 × 100	16.4	0.20	3.84	LNC2V472MSEG
	76.2 × 80	15.7	0.20	3.84	LNC2V472MSEH
5600	63.5 × 115	18.1	0.20	4.20	LNC2V562MSEG
	76.2 × 90	17.6	0.20	4.20	LNC2V562MSEH
6800	63.5 × 135	20.3	0.20	4.62	LNC2V682MSEG
	76.2 × 100	19.7	0.20	4.62	LNC2V682MSEH
8200	76.2 × 115	22.2	0.20	5.00	LNC2V822MSEH
	90 × 90	24.2	0.20	5.00	LNC2V822MSEJ
10000	76.2 × 135	25.2	0.20	5.00	LNC2V103MSEH
	90 × 100	27.1	0.20	5.00	LNC2V103MSEJ
12000	76.2 × 155	28.2	0.20	5.00	LNC2V123MSEH
	90 × 120	30.1	0.20	5.00	LNC2V123MSEJ
15000	90 × 145	35.4	0.20	5.00	LNC2V153MSEJ
18000	90 × 165	39.2	0.20	5.00	LNC2V183MSEJ
22000	90 × 205	43.4	0.20	5.00	LNC2V223MSEJ

400V(2G)					
Cap. (μF)	Size φD × L(mm)	Rated ripple (Arms)	tan δ	Leakage Current (mA)	Code
1000	51 × 60	8.6	0.20	1.89	LNC2G102MSEF
1200	51 × 65	9.3	0.20	2.07	LNC2G122MSEF
1500	51 × 80	10.8	0.20	2.32	LNC2G152MSEF
1800	51 × 85	12.0	0.20	2.54	LNC2G182MSEF
2200	51 × 100	13.0	0.20	2.81	LNC2G222MSEF
	63.5 × 70	12.8	0.20	2.81	LNC2G222MSEG
2700	63.5 × 80	14.5	0.20	3.11	LNC2G272MSEG
	76.2 × 65	14.3	0.20	3.11	LNC2G272MSEH
3300	63.5 × 90	14.9	0.20	3.44	LNC2G332MSEG
	76.2 × 70	15.3	0.20	3.44	LNC2G332MSEH
3900	63.5 × 100	16.5	0.20	3.74	LNC2G392MSEG
	76.2 × 80	17.1	0.20	3.74	LNC2G392MSEH
4700	63.5 × 120	18.8	0.20	4.11	LNC2G472MSEG
	76.2 × 90	18.3	0.20	4.11	LNC2G472MSEH
5600	63.5 × 135	20.9	0.20	4.48	LNC2G562MSEG
	76.2 × 100	20.2	0.20	4.48	LNC2G562MSEH
6800	63.5 × 165	23.8	0.20	4.94	LNC2G682MSEG
	76.2 × 120	23.1	0.20	4.94	LNC2G682MSEH
8200	90 × 90	26.3	0.20	4.94	LNC2G682MSEJ
	76.2 × 145	26.1	0.20	5.00	LNC2G822MSEH
10000	90 × 105	29.5	0.20	5.00	LNC2G822MSEJ
	76.2 × 165	29.5	0.20	5.00	LNC2G103MSEH
12000	90 × 120	33.2	0.20	5.00	LNC2G103MSEJ
	90 × 145	37.1	0.20	5.00	LNC2G123MSEJ
15000	90 × 185	42.9	0.20	5.00	LNC2G153MSEJ
18000	90 × 205	48.2	0.20	5.00	LNC2G183MSEJ

450V(2W)					
Cap. (μF)	Size φD × L(mm)	Rated ripple (Arms)	tan δ	Leakage Current (mA)	Code
1000	51 × 70	9.3	0.20	2.01	LNC2W102MSEF
1200	51 × 80	9.9	0.20	2.20	LNC2W122MSEF
1500	51 × 90	10.4	0.20	2.46	LNC2W152MSEF
1800	51 × 105	11.5	0.20	2.70	LNC2W182MSEF
	63.5 × 70	11.9	0.20	2.70	LNC2W182MSEG
2200	63.5 × 85	12.3	0.20	2.98	LNC2W222MSEG
	76.2 × 65	12.5	0.20	2.98	LNC2W222MSEH
2700	63.5 × 90	13.7	0.20	3.30	LNC2W272MSEG
	76.2 × 75	13.7	0.20	3.30	LNC2W272MSEH
3300	63.5 × 115	15.6	0.20	3.65	LNC2W332MSEG
	76.2 × 85	15.5	0.20	3.65	LNC2W332MSEH
3900	63.5 × 135	17.3	0.20	3.97	LNC2W392MSEG
	76.2 × 90	17.0	0.20	3.97	LNC2W392MSEH
4700	63.5 × 145	19.2	0.20	4.36	LNC2W472MSEG
	76.2 × 115	19.2	0.20	4.36	LNC2W472MSEH
5600	63.5 × 165	21.4	0.20	4.76	LNC2W562MSEG
	76.2 × 135	21.6	0.20	4.76	LNC2W562MSEH
6800	90 × 95	24.2	0.20	4.76	LNC2W562MSEJ
	76.2 × 145	23.8	0.20	5.00	LNC2W682MSEH
8200	90 × 115	27.5	0.20	5.00	LNC2W682MSEJ
	76.2 × 185	27.2	0.20	5.00	LNC2W822MSEH
10000	90 × 135	30.5	0.20	5.00	LNC2W822MSEJ
	90 × 155	34.1	0.20	5.00	LNC2W103MSEJ
12000	90 × 185	38.2	0.20	5.00	LNC2W123MSEJ
15000	90 × 215	43.1	0.20	5.00	LNC2W153MSEJ

500V(2H)					
Cap. (μF)	Size φD × L(mm)	Rated ripple (Arms)	tan δ	Leakage Current (mA)	Code
1000	51 × 85	10.3	0.20	2.12	LNC2H102MSEF
1200	63.5 × 70	10.4	0.20	2.32	LNC2H122MSEG
1500	63.5 × 80	11.6	0.20	2.59	LNC2H152MSEG
1800	63.5 × 90	12.7	0.20	2.84	LNC2H182MSEG
2200	63.5 × 100	14.2	0.20	3.14	LNC2H222MSEG
2700	76.2 × 90	15.8	0.20	3.48	LNC2H272MSEH
3300	76.2 × 105	17.8	0.20	3.85	LNC2H332MSEH
3900	76.2 × 120	19.9	0.20	4.18	LNC2H392MSEH
4700	90 × 105	23.6	0.20	4.59	LNC2H472MSEJ
5600	90 × 120	26.4	0.20	5.00	LNC2H562MSEJ
6800	90 × 145	30.0	0.20	5.00	LNC2H682MSEJ
8200	90 × 165	33.7	0.20	5.00	LNC2H822MSEJ
10000	90 × 205	38.3	0.20	5.00	LNC2H103MSEJ

Rated ripple current (Arms) at 85°C 120Hz

● Frequency coefficient of rated ripple current

Frequency (Hz)	50	60	120	360	1k	10k or more
Coefficient	0.80	0.82	1.00	1.20	1.35	1.40