

REVISIONS

REV	ECO	DESCRIPTION	DATE	BY	APPR
A3	-	RELEASE NEW DRAWING FORMAT	08/OCT/13	DRP	-
A4	-	MATCHED DIMS TO NEW TOOLING	28JAN15	JAH	-

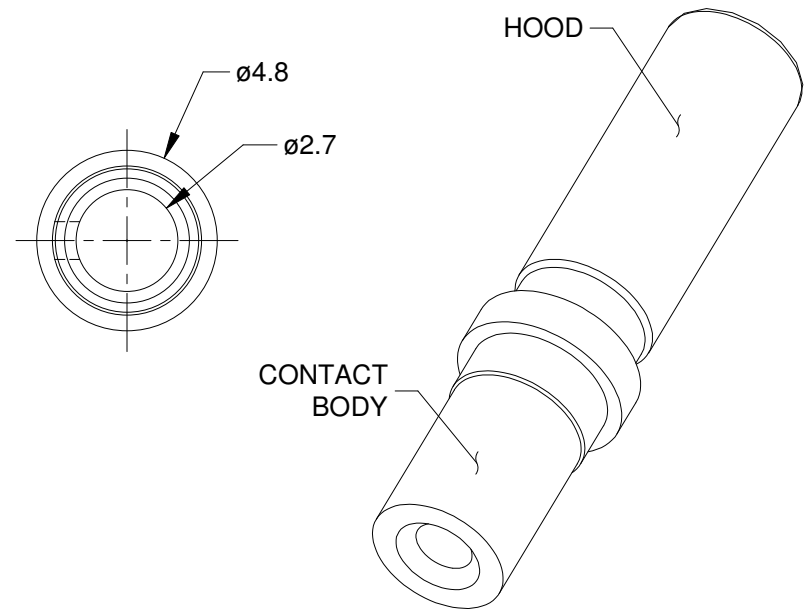
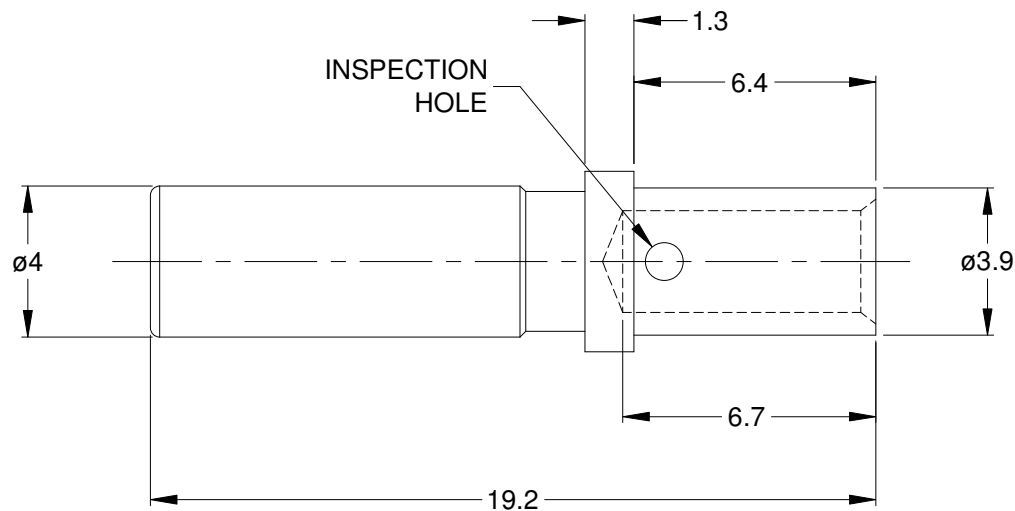

NOTES: UNLESS OTHERWISE SPECIFIED

1. MATERIAL: COPPER ALLOY; NICKEL PLATED
2. CONTACT SIZE: 12
3. SPECIFICATIONS:
 - 3.1 CURRENT RATING: 25 AMP
 - 3.2 CONTACT MILLIVOLT DROP: 60 MILLIVOLT DROP @ 25 AMP TEST CURRENT.
 - 3.3 ROHS COMPLIANT
4. RECOMMENDED WIRE RANGE: 12 - 14 AWG
5. AVAILABLE HAND CRIMPER: CA-5D12
6. ALL DIMENSIONS ARE FOR REFERENCE USE ONLY

AT62-203-12141		DESCRIPTION		ITEM
PART NUMBER		DESCRIPTION		ITEM
QUANTITY	MATERIALS LIST			
UNLESS OTHERWISE SPECIFIED		SIGNATURES		DATE
1) All dimensions are in metric(mm).		DRAWN: D.PARKS		08/OCT/13
2) Tolerances are as follows:		CHECKED:		
1 PL DEC ± 0.30		ENGINEER:		
2 PL DEC ± 0.15		APPROVAL:		
3 PL DEC ± 0.08		CUSTOMER:		
3) Note reference = $\triangle X$		THIS DRAWING IS SUPPLIED FOR INFORMATION ONLY. DESIGN FEATURES, SPECIFICATIONS AND PERFORMANCE DATA SHOWN HEREON ARE THE PROPERTY OF THE AMPHENOL CORPORATION. NO RIGHTS OF REPRODUCTION ARE IMPLIED. ALL DIMENSIONS ARE SUBJECT TO NORMAL MANUFACTURING VARIATIONS.		
MATERIAL SPECIFICATIONS:		CONTACT, SOCKET, SOLID, SIZE 12, 12-14 AWG, ATP & AHD-6 SERIES		
PROCESS SPECIFICATIONS:		SIZE	TYPE	DWG NO:
NEXT ASSY:		A	C-	AT62-203-12141
		SCALE: NONE		REVISION A4
		SHEET 1 OF 1		

Mouser Electronics

Authorized Distributor

Click to View Pricing, Inventory, Delivery & Lifecycle Information:

[Amphenol:](#)

[AT62-203-12141](#)