

Micropower Synchronous Multitopology Controller with 42V Input Capability

FEATURES

- Easily Configurable as a Synchronous Buck, Boost, SEPIC, ZETA or Nonsynchronous Buck-Boost Converter
- Wide Input Range: 4.5V to 42V (V_{IN} Can Operate to 0V, when $EXTV_{CC} > 4.5V$)
- Automatic Low Noise Burst Mode® Operation
- Low I_Q in Burst Mode Operation (15 μ A Operating)
- Input Voltage Regulation for High Impedance Source
- 100% Duty Cycle in Dropout (Buck Mode)
- 2A Gate Drivers (BG and TG)
- Adjustable Soft-Start with One Capacitor
- Frequency Programmable from 100kHz to 750kHz
- Can Be Synchronized to External Clock
- Available in 20-Lead TSSOP and 20-Lead 3mm \times 4mm QFN Packages

APPLICATIONS

- General Purpose DC/DC Conversion
- Automotive Systems
- Industrial Supplies
- Solar Panel Power Converter

DESCRIPTION

The LT[®]8711 is a multitopology current mode PWM controller that can easily be configured as a synchronous buck, boost, SEPIC, ZETA or as a nonsynchronous buck-boost converter. Its dual gate drive voltage inputs optimize gate driver efficiency.

The 15 μ A no-load quiescent current with the output voltage in regulation extends operating run time in battery powered systems. Low ripple Burst Mode operation enables high efficiency at very light loads while maintaining low output voltage ripple. The LT8711's fixed switching frequency can be set from 100kHz to 750kHz or can be synchronized to an external clock.

The additional features include 100% duty cycle capability when in buck mode, a topology selection pin and adjustable soft-start. LT8711 is available in the 20-lead TSSOP and 20-lead 3mm \times 4mm QFN packages.

All registered trademarks and trademarks are the property of their respective owners.

TYPICAL APPLICATION

400kHz 5V to 40V Input/12V Output Nonsynchronous Buck Boost

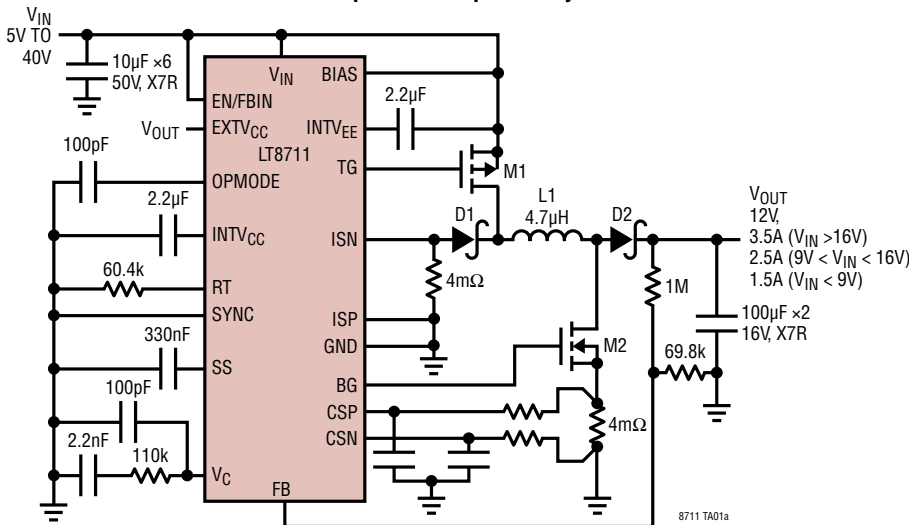

Efficiency vs Load Current

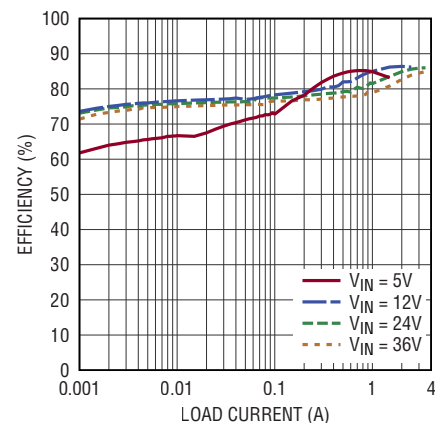

LT8711

ABSOLUTE MAXIMUM RATINGS

(Note 1)

V_{IN} Voltage	-0.3V to 42V	CSN Voltage	CSP - 0.3V to CSP + 0.3V
BIAS Voltage	-0.3V to 42V	ISP Voltage	ISN - 0.3V to ISN + 0.3V
EXTV _{CC} Voltage	-0.3V to 42V	ISN Voltage	-0.3V to BIAS
BG, TG Voltage	Note 2	INTV _{CC} Voltage	-0.3V to 5.5V
FB Voltage	-0.3V to 5.5V	RT Voltage	-0.3V to 5.5V
V _C Voltage	-0.3V to 2.5V	SS Voltage	-0.3V to 5.5V
EN/FBIN Voltage	-0.3V to MAX(V_{IN} , EXTV _{CC})	Operating Junction Temperature Range	
SYNC Voltage	-0.3V to 5.5V	LT8711E	-40°C to 125°C
OPMODE Voltage	-0.3V to 5.5V	LT8711	-40°C to 125°C
INTV _{EE} Voltage	Note 2	Storage Temperature Range	-65°C to 150°C
CSP Voltage	-0.3V to 42V	Lead Temperature (Soldering, 10 sec)	300°C

PIN CONFIGURATION

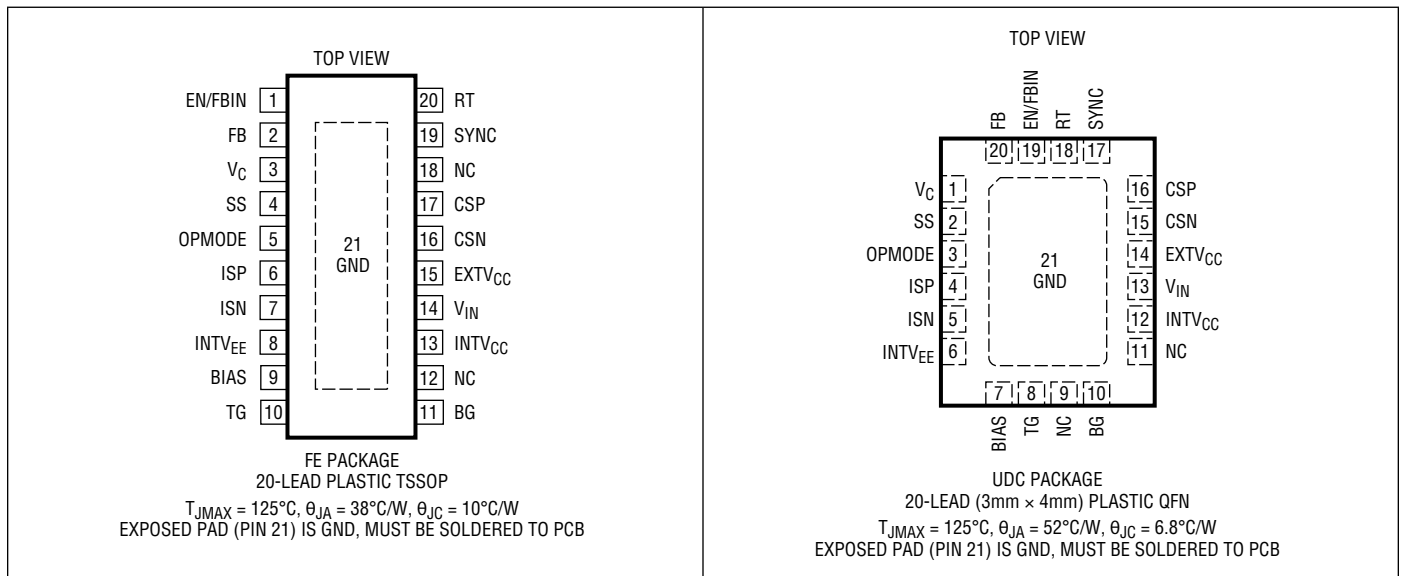

ORDER INFORMATION <http://www.linear.com/product/LT8711#orderinfo>

LEAD FREE FINISH	TAPE AND REEL	PART MARKING*	PACKAGE DESCRIPTION	TEMPERATURE RANGE
LT8711EFE#PBF	LT8711EFE#TRPBF	LT8711 FE	20-Lead TSSOP	-40°C to 125°C
LT8711IFE#PBF	LT8711IFE#TRPBF	LT8711 FE	20-Lead TSSOP	-40°C to 125°C
LT8711EUDC#PBF	LT8711EUDC#TRPBF	LGQJ	20-Lead 3mm × 4mm QFN	-40°C to 125°C
LT8711IUDC#PBF	LT8711IUDC#TRPBF	LGQJ	20-Lead 3mm × 4mm QFN	-40°C to 125°C

Consult ADI Marketing for parts specified with wider operating temperature ranges. *The temperature grade is identified by a label on the shipping container.

For more information on lead free part marking, go to: <http://www.linear.com/leadfree/>

For more information on tape and reel specifications, go to: <http://www.linear.com/tapeandreel/>. Some packages are available in 500 unit reels through designated sales channels with #TRMPBF suffix.

ELECTRICAL CHARACTERISTICS The ● denotes the specifications which apply over the full operating temperature range, otherwise specifications are at $T_A = 25^\circ\text{C}$. $V_{IN} = 12\text{V}$, $V_{BIAS} = 12\text{V}$, unless otherwise noted (Note 3).

PARAMETER	CONDITIONS		MIN	TYP	MAX	UNITS
V_{IN} Operating Voltage Range	$V_{EXTVCC} = 0\text{V}$ $V_{EXTVCC} = 4.5\text{V}$	●	4.5		42	V
		●	0		42	V
Quiescent Current in Normal Operation ($I_{VIN} + I_{EXTVCC} + I_{BIAS}$)	$V_{EN/FBIN} = 2.5\text{V}$, Not Switching			2.0	2.5	mA
Quiescent Current in Burst Mode Operation ($I_{VIN} + I_{EXTVCC} + I_{BIAS}$)	$V_{FB} = V_{FB_REG} + 3\text{mV}$			15	25	μA
Quiescent Current in Shutdown ($I_{VIN} + I_{EXTVCC} + I_{BIAS}$)	$V_{EN/FBIN} = 0\text{V}$			1	2	μA
FB Output Regulation Voltage, V_{FB_REG}		●	784	800	816	mV
			795	800	805	mV
FB Line Regulation	$4.5\text{V} \leq V_{IN} \leq 42\text{V}$			0.01	0.05	%/V
FB Pin Input Bias Current	$V_{FB} = 0.8\text{V}$	●	-50	0	50	nA
Error Amp Transconductance	$\Delta I = \pm 5\mu\text{A}$			250		μmhos
Error Amp Voltage Gain				90		dB
Maximum Current Sense Voltage, $V_{CSP} - V_{CSN}$	Minimum Duty Cycle Maximum Duty Cycle	●	46	50	54	mV
		●	26	33	40	mV
Switching Frequency, f_{OSC}	$R_T = 30.3\text{k}$ $R_T = 247\text{k}$	●	675	750	825	kHz
		●	85	100	115	kHz
Switching Frequency Range	Free-Running Synchronizing	●	85		825	kHz
		●	140		750	kHz
SYNC Input Voltage High		●	1.3			V
SYNC Input Voltage Low		●			0.4	V
SYNC Clock Pulse Duty Cycle	$V_{SYNC} = 0\text{V}$ to 2V , $f_{SYNC} = 500\text{kHz}$		20		80	%
Recommended SYNC Ratio f_{SYNC}/f_{OSC}			0.8		1.2	
INTV _{CC} Voltage	$I_{INTVCC} = 10\text{mA}$	●	4.75	5	5.25	V
INTV _{CC} Line Regulation	$6\text{V} \leq V_{IN} \leq 42\text{V}$, $V_{EXTVCC} = 0$, $I_{INTVCC} = 10\text{mA}$ $6\text{V} \leq V_{EXTVCC} \leq 42\text{V}$, $V_{IN} = 0$, $I_{INTVCC} = 10\text{mA}$			-0.003	-0.03	%/V
				-0.003	-0.03	%/V
INTV _{CC} Load Regulation	$I_{INTVCC} = 0\text{mA}$ to 40mA			-1	-2	%
INTV _{CC} Maximum External Load Current	Internal Load Current = 40mA			10		mA
INTV _{CC} Undervoltage Lockout	INTV _{CC} Rising INTV _{CC} Falling	●	3.9	4.1	4.3	V
		●	3.45	3.6	3.75	V
INTV _{CC} Undervoltage Lockout Hysteresis				500		mV
INTV _{EE} Voltage, $V_{BIAS} - V_{INTVEE}$	$I_{INTVEE} = 10\text{mA}$	●	4.85	5.15	5.4	V
INTV _{EE} Undervoltage Lockout, $V_{BIAS} - V_{INTVEE}$	$V_{BIAS} - V_{INTVEE}$ Rising $V_{BIAS} - V_{INTVEE}$ Falling	●	3.6	3.85	4.1	V
		●	3.4	3.6	3.8	V
INTV _{EE} Undervoltage Lockout Hysteresis, $V_{BIAS} - V_{INTVEE}$				250		mV
BG Rise Time	$C_{BG} = 3.3\text{nF}$ (Note 4)			14		ns
BG Fall Time	$C_{BG} = 3.3\text{nF}$ (Note 4)			12		ns
TG Rise Time	$C_{TG} = 3.3\text{nF}$ (Note 4)			11		ns
TG Fall Time	$C_{TG} = 3.3\text{nF}$ (Note 4)			14		ns
BG and TG Non-Overlap Time	TG Rising to BG Rising, $C_{BG} = C_{TG} = 3.3\text{nF}$ (Note 4)			70		ns
BG and TG Non-Overlap Time	BG Falling to TG Falling, $C_{BG} = C_{TG} = 3.3\text{nF}$ (Note 4)			70		ns
Minimum On-Time	$C_{BG} = C_{TG} = 3.3\text{nF}$			100		ns

ELECTRICAL CHARACTERISTICS

The ● denotes the specifications which apply over the full operating temperature range, otherwise specifications are at $T_A = 25^\circ\text{C}$. $V_{IN} = 12\text{V}$, $V_{BIAS} = 12\text{V}$, unless otherwise noted (Note 3).

PARAMETER	CONDITIONS		MIN	TYP	MAX	UNITS
SS Charge Current	$V_{SS} = 0\text{V}$, Current Flows Out of SS pin	●	6	10	15	μA
SS Low Detection Voltage	Part Exiting Undervoltage Lockout	●	65	85	105	mV
EN/FBIN Active Mode	EN/FBIN Rising	●	1.28	1.35	1.42	V
EN/FBIN Chip Enable	EN/FBIN Rising	●	0.97	1.03	1.11	V
	EN/FBIN Falling	●	0.94	1	1.08	V
EN/FBIN Chip Enable Hysteresis				30		mV
EN/FBIN Input Voltage Low	Shutdown Mode	●			0.2	V
EN/FBIN Current Limit Adjustment Voltage	Full Current Limit	●			1.27	V
	Near Zero Current Limit	●	1.12			V
EN/FBIN Pin Input Bias Current	$V_{EN/FBIN} = 12\text{V}$	●	-50	0	50	nA
EN/FBIN Amp Transconductance	$V_{FB} = 0.6\text{V}$			40		μmhos
EN/FBIN Amp Voltage Gain	$V_{FB} = 0.6\text{V}$			100		V/V

Note 1: Stresses beyond those listed under Absolute Maximum Ratings may cause permanent damage to the device. Exposure to any Absolute Maximum Rating condition for extended periods may affect device reliability and lifetime.

Note 2: Do not apply a positive or negative voltage or current source to BG, TG and INTV_{EE} pins, otherwise permanent damage may occur.

Note 3: The LT8711E is guaranteed to meet performance specifications from 0°C to 125°C junction temperature. Specifications over the -40°C to 125°C operating temperature range are assured by design,

characterization and correlation with statistical process controls. The LT8711 is guaranteed over the full -40°C to 125°C operating junction temperature range.

Note 4: Rise and fall times are measured using 10% and 90% levels. Delay times are measured using 50% levels.

Note 5: This IC includes overtemperature protection that is intended to protect the device during momentary overload conditions. Junction temperature will exceed 125°C when overtemperature protection is active. Continuous operation over the specified maximum operating junction temperature may impair device reliability.

TYPICAL PERFORMANCE CHARACTERISTICS $T_A = 25^\circ\text{C}$, unless otherwise noted.

Maximum Current Limit vs Duty Cycle (CSP-CSN)

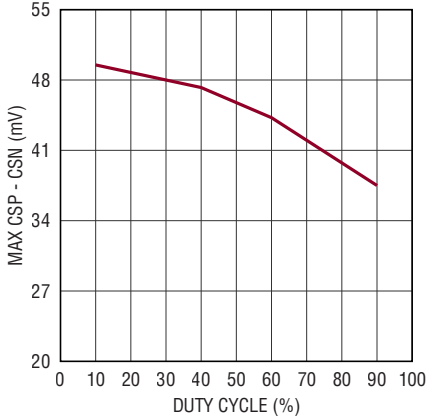

8711 G01

Maximum Current Limit vs SS (CSP-CSN)

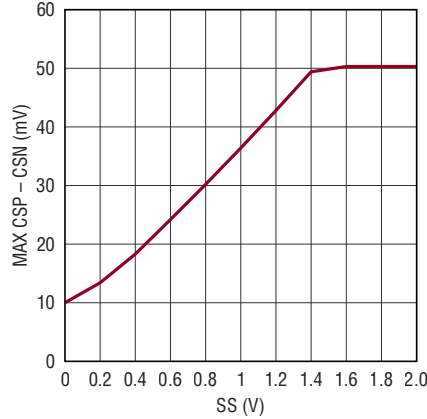

8711 G02

Output Voltage Regulation (V_{FB_REG})

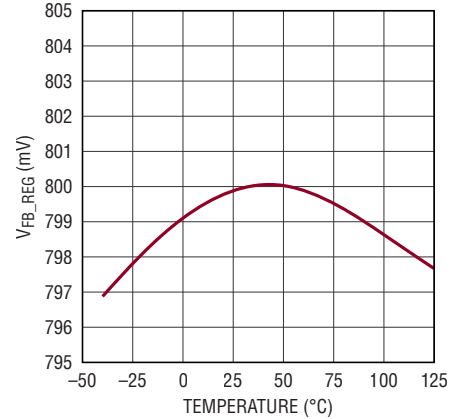

8711 G03

Input Voltage Regulation (EN/FBIN)

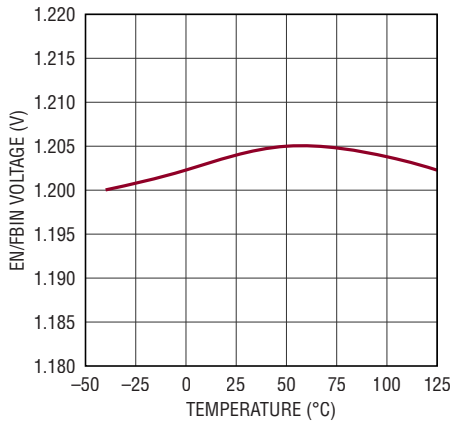

8711 G04

EN/FBIN Chip Enable Threshold

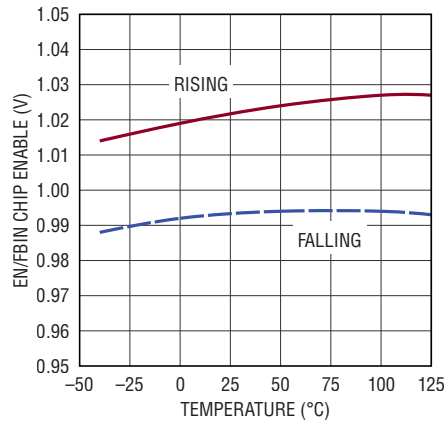

8711 G05

EN/FBIN Active Mode Threshold

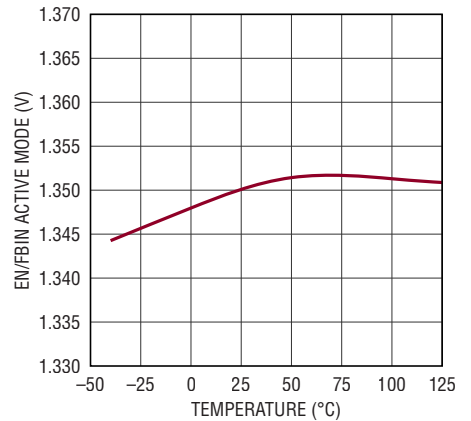

8711 G06

Input Voltage Regulation vs FB (EN/FBIN)

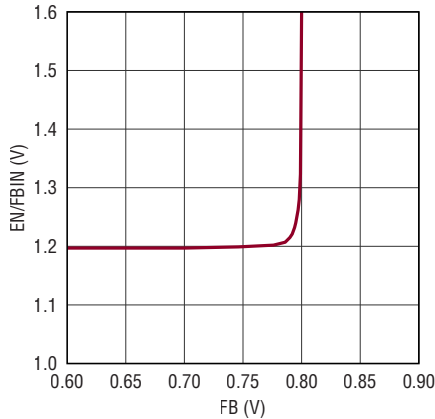

8711 G07

CSN Bias Current

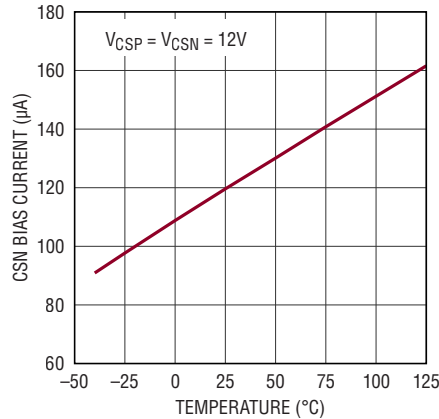

8711 G08

ISN Bias Current

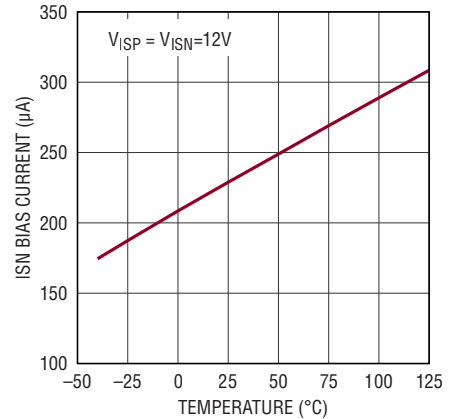

8711 G09

TYPICAL PERFORMANCE CHARACTERISTICS $T_A = 25^\circ\text{C}$, unless otherwise noted.

DCM Thresholds (ISP- I_{SN})

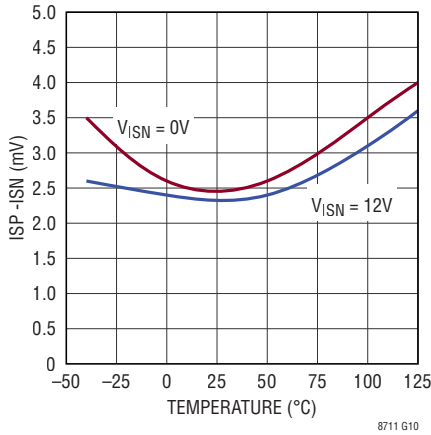

Oscillator Frequency vs Temperature

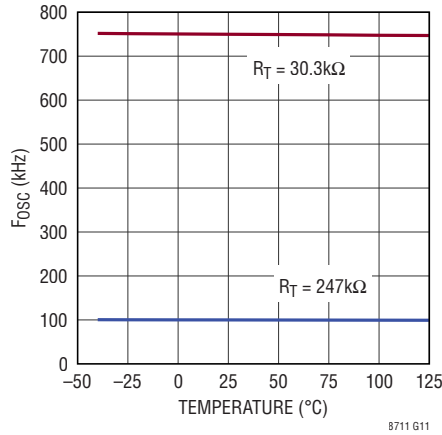

BG Transition Time vs Cap Load

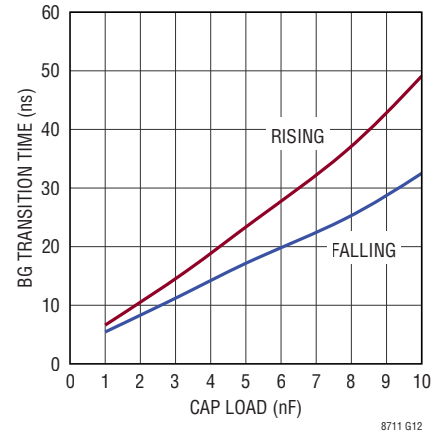

TG Transition Time vs Cap Load

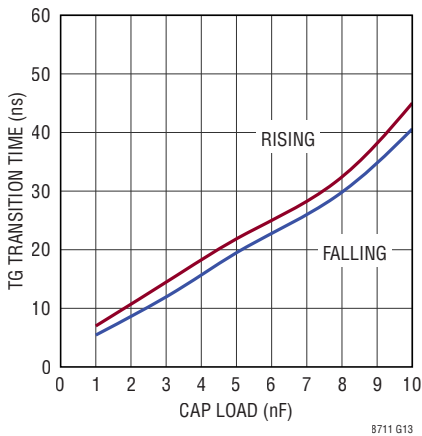

Minimum Operating Input Voltage

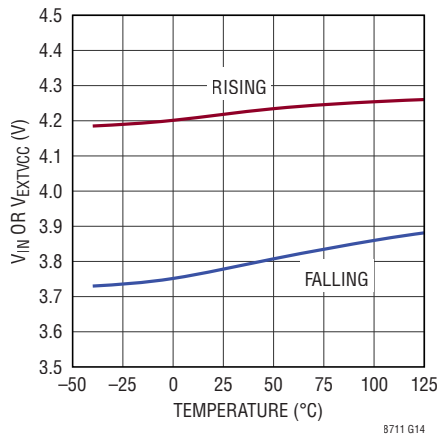

INTV_{CC} vs Temperature

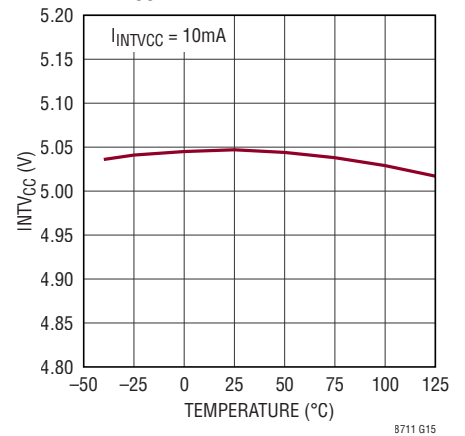

INTV_{CC} UVLO vs Temperature

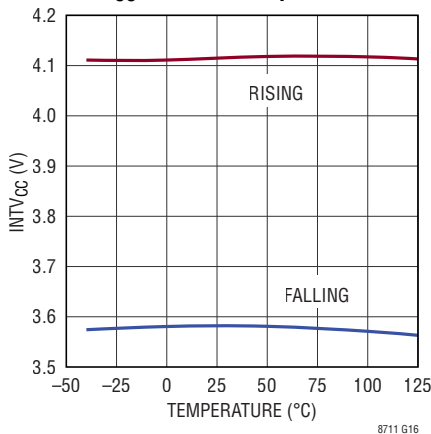

INTV_{CC} Current Limit vs V_{IN} or EXT_{VCC}

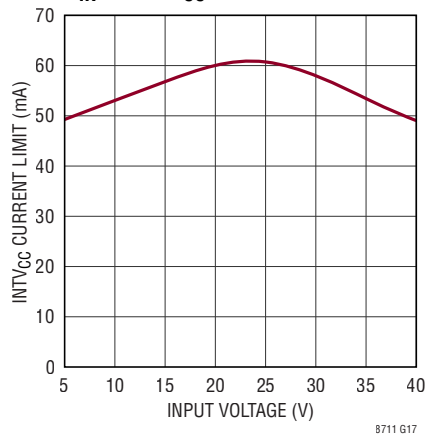

INTV_{CC} Dropout from V_{IN} or EXT_{VCC}

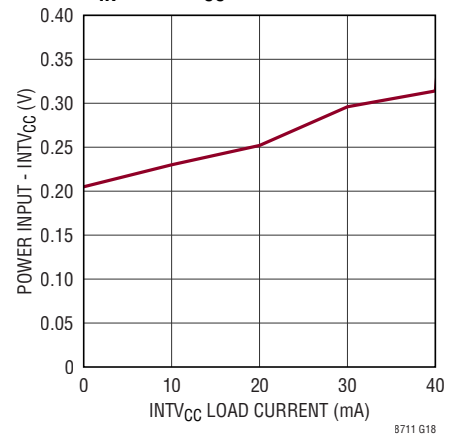

TYPICAL PERFORMANCE CHARACTERISTICS $T_A = 25^\circ\text{C}$, unless otherwise noted.

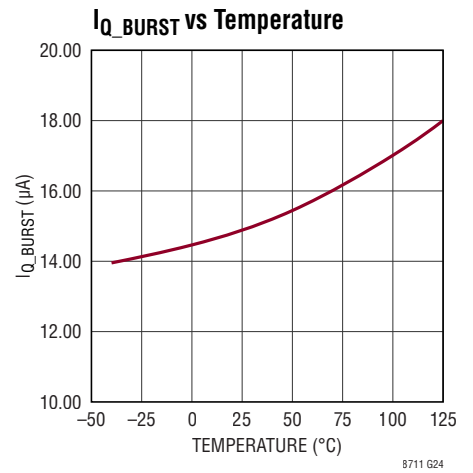
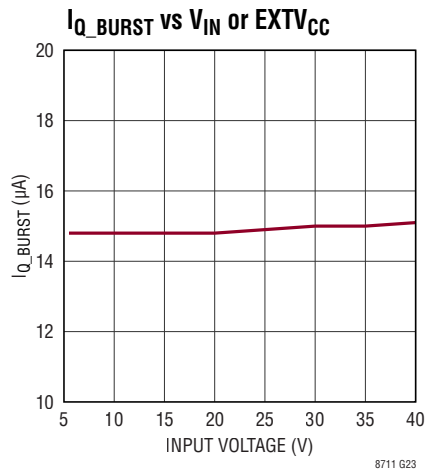
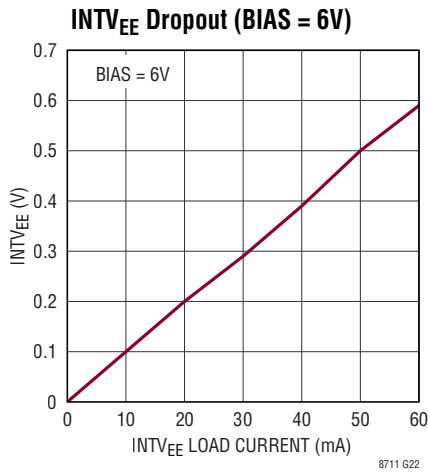
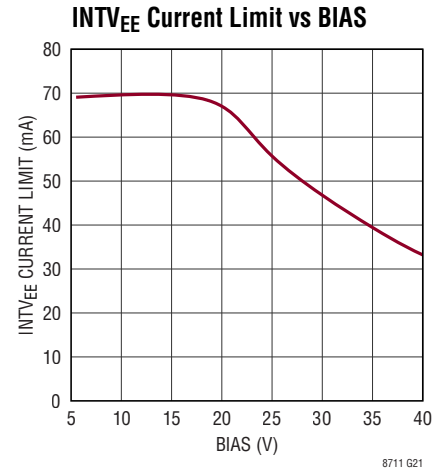
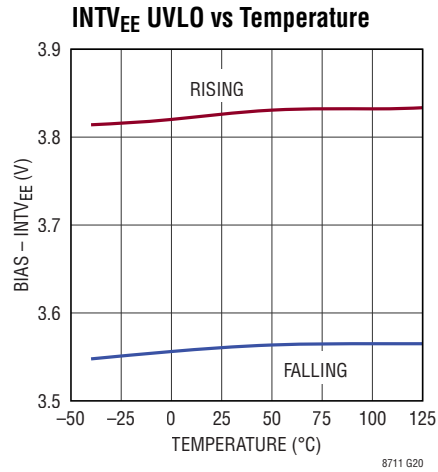
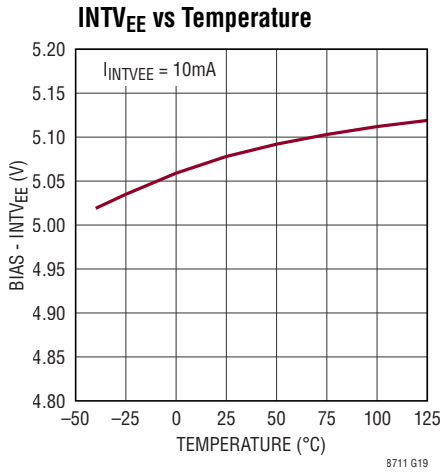

PIN FUNCTIONS (TSSOP/QFN)

EN/FBIN (Pin 1/Pin 19): Enable and Input Voltage Regulation Pin. In conjunction with the UVLO (undervoltage lockout) circuit, this pin is used to enable/disable the chip and restart the soft-start sequence. The EN/FBIN pin is also used to limit the switching regulator current to avoid collapsing the input supply. Drive below 0.2V to disable the chip with very low quiescent current. Drive above 1.03V (typical) to activate the chip. The commanded input current will adjust when the EN/FBIN pin voltage is between 1.12V and 1.27V. Drive above 1.35V (typical) to activate switching with no reduction in input current and restart the soft-start sequence. See the Block Diagram and Applications section for more information. Do not float this pin.

FB (Pin 2/Pin 20): Feedback Input Pin. The LT8711 regulates the FB pin to 0.8V. Connect the feedback resistor divider tap to this pin.

V_C (Pin 3/Pin 1): Error Amplifier Output Pin. Tie external compensation network to this pin.

SS (Pin 4/Pin 2): Soft Start Pin. Place a soft-start capacitor here. Upon start-up, the SS pin will be charged by a 410k resistor to about 4.3V. During an overtemperature or UVLO condition, the SS pin will be quickly discharged to reset the part. Once those conditions are clear, the part will attempt to restart.

OPMODE (Pin 5/Pin 3): Topology Selection Pin. Tie this pin to ground to select buck/ZETA mode. Tie to INTV_{CC} to select SEPIC/boost mode. Tie to a 100pF capacitor to GND to select nonsynchronous buck-boost mode.

ISP & ISN (Pins 6 & 7/ Pins 4 & 5): Current Sense Positive and Negative Input Pins respectively. Kelvin connect ISP and ISN pins to a sense resistor.

INTV_{EE} (Pin 8/Pin 6): 5V Below BIAS LDO Regulator Pin. Must be locally bypassed with a minimum capacitance of 2.2μF to BIAS. This pin sets the bottom rail for the TG gate driver. The TG gate driver can begin switching when BIAS – INTV_{EE} exceeds 3.6V (typical).

BIAS (Pin 9/Pin 7): Power Supply for the TG PFET Driver. Must be locally bypassed with a minimum capacitance of 2.2μF to INTV_{EE}. The BIAS pin sets the top rail for the TG gate driver.

TG (Pin 10/Pin 8): PFET Gate Drive Pin. Low and high levels are INTV_{EE} and BIAS respectively with a 2A drive capability.

BG (Pin 11/Pin 10): NFET Gate Drive Pin. Low and high levels are GND and INTV_{CC} respectively with a 2A drive capability.

NC (Pin 12/Pin 9): No Connection. Do not connect. Must be floated.

INTV_{CC} (Pin 13/Pin 12): 5V Dual Input LDO Regulator Pin. Must be locally bypassed with a minimum capacitance of 2.2μF to GND. Logic will choose to run INTV_{CC} from the VIN or EXTV_{CC} pins. A maximum 10mA external load can connect to the INTV_{CC} pin. The undervoltage lockout on INTV_{CC} is 3.6V (typical). The BG gate driver can begin switching when INTV_{CC} exceeds 4.1V (typical).

V_{IN} (Pin 14/Pin 13): Input Supply Pin. Must be locally bypassed. Can run down to 0V as long as EXTV_{CC} > 4.5V.

EXTV_{CC} (Pin 15/Pin 14): Alternate Input Supply Pin. Must be locally bypassed. Can run down to 0V as long as V_{IN} > 4.5V.

CSN & CSP (Pins 16 & 17/ Pins 15 & 16): Current Sense Negative and Positive Input Pins Respectively. Kelvin connect CSN and CSP pins to a sense resistor to limit the input current. The maximum sense voltage at low duty cycle is 50mV.

NC (Pin 18/Pin 11): No Connection. Do not connect. Must be floated.

SYNC (Pin 19/Pin 17): To synchronize the switching frequency to an outside clock, simply drive this pin with a clock. The high voltage level of the clock must exceed 1.3V, and the low level must be less than 0.4V. Drive this pin to less than 0.4V to revert to the internal free running clock. See the Applications Information section for more information.

RT (Pin 20/Pin 18): Timing Resistor Pin. Adjusts the LT8711's switching frequency. Place a resistor from this pin to ground to set the frequency to a fixed free running level. Do not float this pin.

GND (Pin 21/Pin 21): Ground. Must be soldered directly to the local ground plane.

BLOCK DIAGRAM

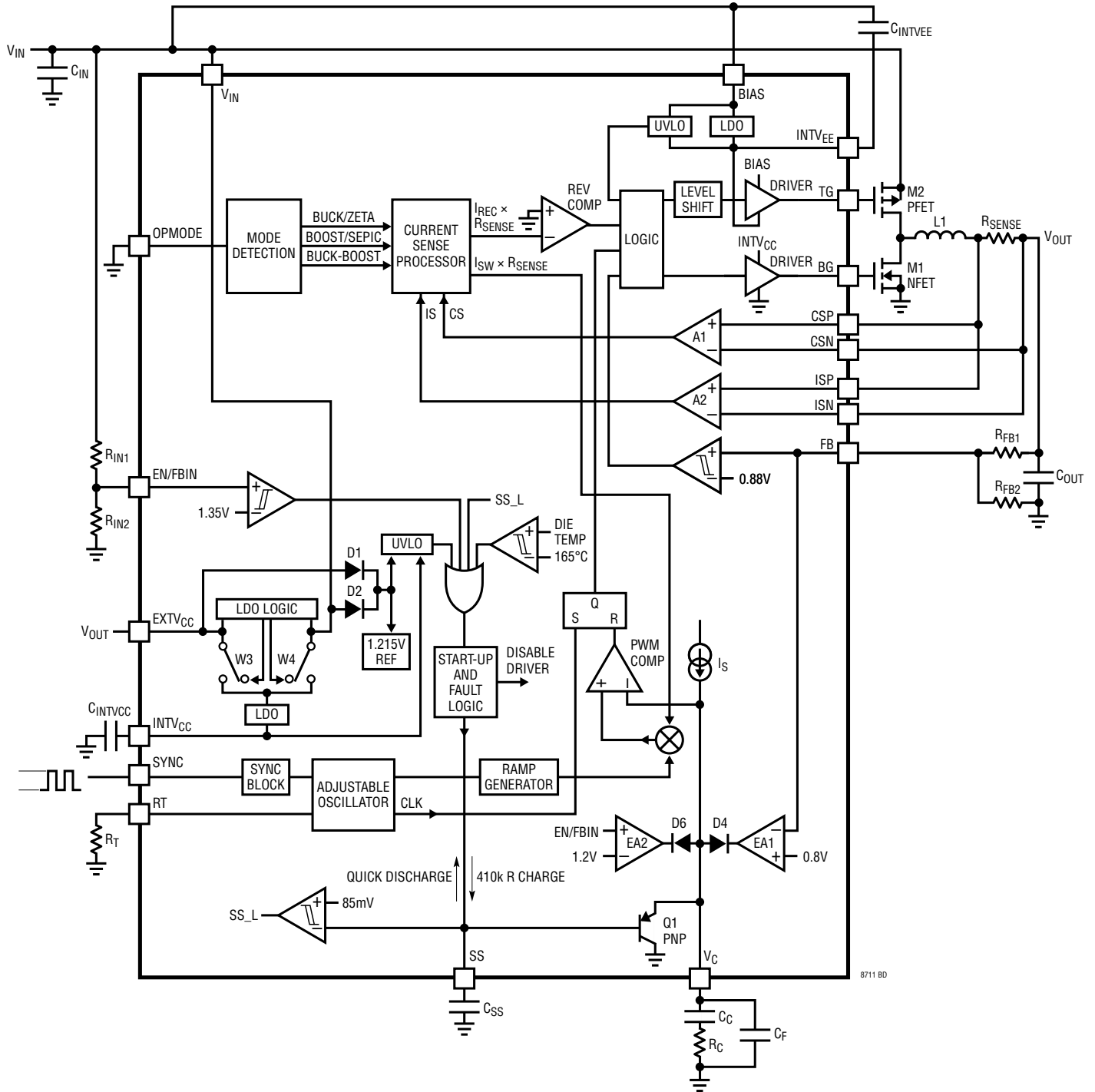

8711 BD

START-UP AND FAULT SEQUENCE

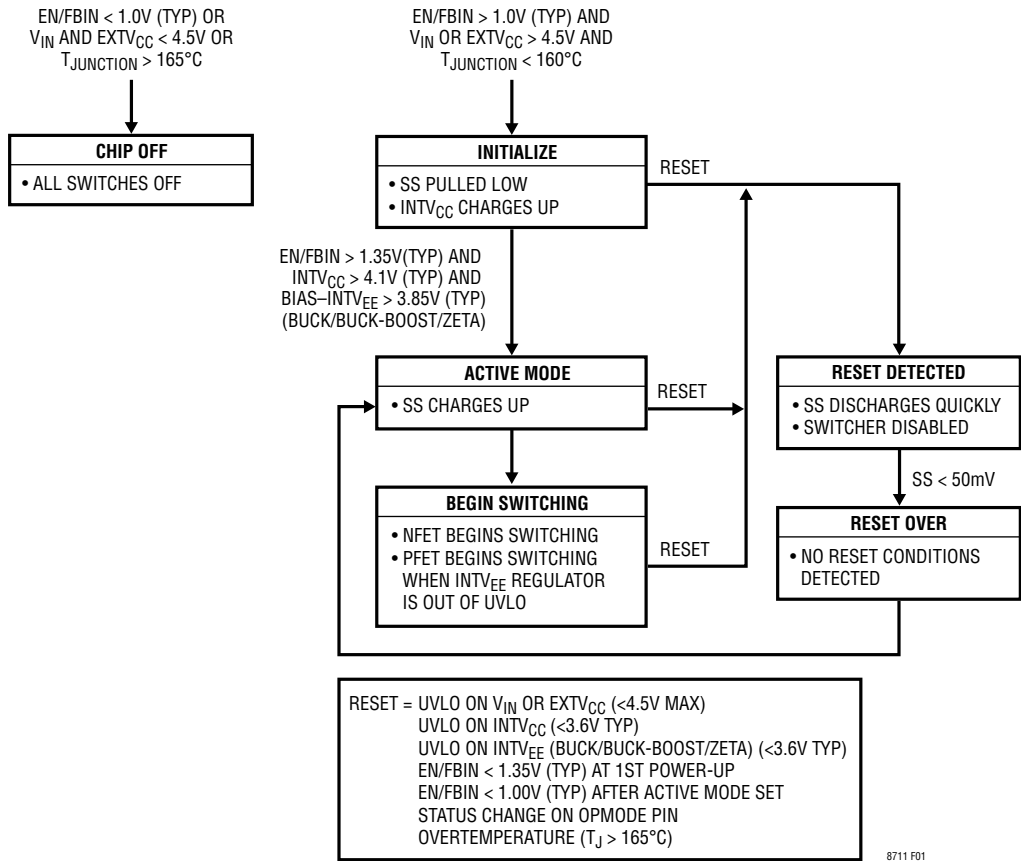

Figure 1. State Diagram

OPERATION

OPERATION—OVERVIEW

The LT8711 uses a constant frequency, current mode control scheme to provide excellent line and load regulation. The part's undervoltage lockout (UVLO) function, together with soft-start, offers a controlled means of starting up. Output voltage and input voltage have control over the commanded peak current which allows a wide range of applications to be built using the LT8711. Synchronous switching makes high efficiency and high output current applications possible. When operating at light load condition, the LT8711 will enter burst mode to minimize switching loss. Refer to the Block Diagram and the State Diagram (Figure 1) for the following description of the part's operation.

OPERATION—TOPOLOGY SELECTING

The 8711 can be configured as a synchronous buck, boost, SEPIC, ZETA or nonsynchronous buck-boost converter by configuration of the OPMODE pin.

When the OPMODE pin is connected to GND, the controller operates in buck/ZETA mode.

When the OPMODE pin is connected to the INTV_{CC} pin, the controller operates in SEPIC/boost mode.

When the OPMODE pin is tied to a 100pF capacitor to GND, the controller operates in nonsynchronous buck-boost mode.

OPERATION—START-UP

Several functions are provided to enable a very clean start-up of the LT8711.

Precise Turn-On Voltages

The EN/FBIN pin has two voltage levels for activating the part: one that enables the part and allows internal rails to operate and a 2nd voltage threshold which activates a soft-start cycle and switching can begin. To enable the part, take the EN/FBIN pin above 1.03V (typical). This comparator has 50mV of hysteresis to protect against glitches and slow ramping. To activate a soft-start cycle and allow switching, take EN/FBIN above 1.35V (typical). When EN/FBIN exceeds 1.35V (typical), the logic state is

latched so that if EN/FBIN drops between 1.03V to 1.35V (typical), the SS pin is not pulled low by the EN/FBIN pin. The EN/FBIN pin is also used for input voltage regulation which is at 1.200V (typical). Input voltage regulation is explained in more detail in the Operation—Regulation section. Taking the EN/FBIN pin below 0.2V shuts down the chip, resulting in extremely low quiescent current. See Figure 2 that illustrates the different EN/FBIN voltage thresholds.

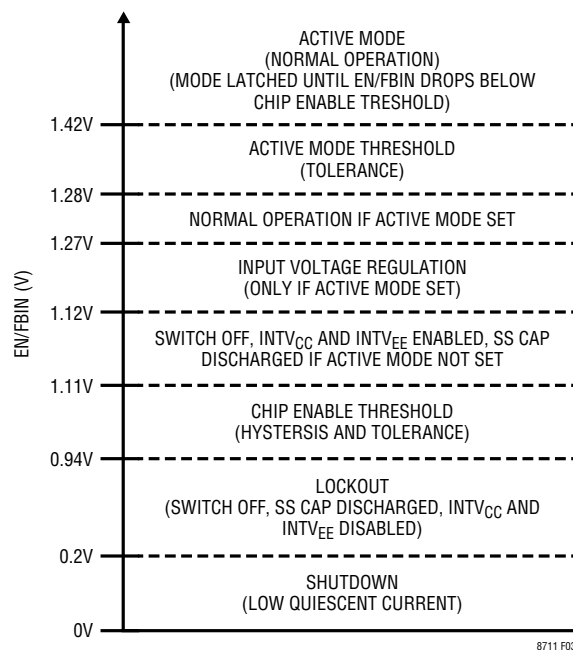

Figure 2. EN/FBIN Modes of Operation

Undervoltage Lockout (UVLO)

The LT8711 has internal UVLO circuitry that disables the chip when the greater of V_{IN} or EXT_V_{CC} < 3.6V (typical). The EN/FBIN pin can also be used to create a configurable UVLO.

Soft-Start of Switch Current

The soft-start circuitry provides for a gradual ramp-up of the switch current (refer to Max Current Limit vs SS in Typical Performance Characteristics). When the part is brought out of shutdown, the external SS capacitor is first discharged which resets the states of the logic circuits in the chip. Once the chip is in active mode, an integrated 410k resistor pulls the SS pin to ~4.3V at a ramp rate set by the external capacitor connected to the pin. Typical values for the soft-start capacitor range from 100nF to 1µF.

OPERATION

OPERATION—REGULATION

Use the Block Diagram when stepping through the following description of the LT8711 operating in regulation. The LT8711 has two modes of regulation:

1. Output Voltage (via FB pin)
2. Input Voltage (via EN/FBIN pin)

Both of these regulation loops control the peak commanded current. At the start of each oscillator cycle, the SR latch is set, which first turns off the external rectifier switch (NFET in Block Diagram), and then turns on the external main switch (PFET in Block Diagram). The PFET's current flows through an external current sense resistor (RSENSE) generating a voltage proportional to the PFET switch current. This voltage is then amplified by A1 and added to a stabilizing ramp. The resulting sum is fed into the positive terminal of the PWM comparator. When the voltage on the positive input of the PWM comparator exceeds the voltage on the negative input (V_C pin), the SR latch is reset, turning off the PFET and then turning on the NFET. The voltage on the V_C pin is controlled by one of the regulation loops, or a combination of regulation loops.

Slope compensation provides stability in constant frequency current mode control architectures by preventing subharmonic oscillations at high duty cycles. This is accomplished internally by adding a compensating ramp to the positive terminal of the PWM comparator.

Output Voltage Regulation

The error amplifier servos the V_C node by comparing the voltage on the FB pin with an internal 0.800V reference. When the load current increases it causes a reduction in the feedback voltage relative to the reference causing the error amplifier to raise the V_C voltage. In this manner, the FB error amplifier sets the correct peak current level to maintain output voltage regulation.

Input Voltage Regulation

A resistor divider from the converter's input voltage to the EN/FBIN pin sets the input voltage regulation point. The EN/FBIN pin voltage connects to the positive input of amplifier EA2. The V_C pin voltage is set by EA2, which is the amplified difference between the EN/FBIN pin voltage and an internal 1.200V reference voltage. In this manner, the EN/FBIN error amplifier sets the correct peak current level to maintain input voltage regulation.

OPERATION—RESET CONDITIONS

The LT8711 has three reset cases. When the part is in reset, the SS pin is pulled low and both power switches, NFET and PFET, are forced off. Once all of the reset conditions are gone, the part is allowed to begin a soft-start sequence and switching can commence. Each of the following events can cause the LT8711 to be in reset:

1. UVLO
 - a. The greater of V_{IN} and $EXTV_{CC}$ is $< 4.5V$ (maximum)
 - b. UVLO on $INTV_{CC}$. $INTV_{CC} < 3.6V$ (typical)
 - c. UVLO on $INTV_{EE}$. $V_{BIAS} - V_{INTV_{EE}} < 3.6V$ (typical) unless BOOST/SEPIC topology is selected
 - d. $EN/FBIN < 1.35V$ (typical) at first power-up
 - e. $EN/FBIN < 1.00V$ (typical) after active mode set
2. OPMODE pin status changes
3. Die Temperature $> 165^{\circ}C$

OPERATION—POWER SWITCH CONTROL

The external PFET and NFET switches are never on at the same time (except buck-boost mode), and there is a non-overlap time of about 100ns to prevent cross conduction.

OPERATION

Light Load Operation Modes

The SYNC pin can be used to tell the LT8711 to operate in FCM regardless of load current, or operate in DCM and Burst Mode at light loads.

SYNC = logic high: FCM

SYNC = logic low: DCM or Burst Mode operation

If a clock is applied to the SYNC pin the part will synchronize to an external clock frequency and operate in FCM mode.

OPERATION—AUTOMATIC LOW NOISE Burst Mode OPERATION

At no load or very light load condition, high FB voltage causes V_C to decrease. When V_C voltage is lower than a threshold voltage, the controller operates in Burst Mode to minimize switching loss. Between bursts, all circuitry associated with controlling the output switch is shut down, reducing the average input supply current to 15 μ A in a typical application. Low standby power and higher conversion efficiency is thus achieved. To optimize the quiescent current performance at light loads, the current in the feedback resistor divider must be minimized as it appears to the output as load current.

OPERATION—LDO REGULATORS (INTV_{CC} AND INTV_{EE})

The INTV_{CC} LDO regulates at 5.0V (typical) and is used as the top rail for the BG gate driver. The INTV_{CC} LDO can run from V_{IN} or EXT V_{CC} and will intelligently select to run from the best rail to minimize power loss in the chip, but at the same time, select the proper input for maintaining INTV_{CC} as close to 5.0V as possible. The INTV_{CC} regulator also has safety features to limit the power dissipation in the internal pass device and also to prevent it from damage if the pin is shorted to ground. The UVLO threshold on INTV_{CC} is 3.6V (typical), and the LT8711 will be in reset until the LDO comes out of UVLO.

The INTV_{EE} regulator regulates to 5.15V (typical) below the BIAS pin voltage. The BIAS and INTV_{EE} voltages are used for the top and bottom rails of the TG gate driver respectively. Just like the INTV_{CC} regulator, the INTV_{EE} regulator has a safety feature to limit the power dissipation in the internal pass device. The TG pin can begin switching only after the INTV_{EE} regulator comes out of UVLO (3.85V typical across the BIAS and INTV_{EE} pins). When the INTV_{EE} regulator is in UVLO, for the boost and SEPIC topologies, the bottom switch is allowed to switch. The output current would flow through the body diode of the PFET. To protect the PFET from thermal damage under this condition, the maximum commanded current is folded back to 27mV (typical) across the CSP-CSN pins.

APPLICATIONS INFORMATION

BUCK CONVERTER COMPONENT SELECTION

The LT8711 can be configured as a buck converter as in Figure 3.

For a desired output current and output voltage over a given input voltage range, Table 1 is a step-by-step set of equations to calculate component values for the LT8711 when operating as a buck converter. Refer to more detail in this section and the Appendix for further information on the design equations presented in Table 1.

Variable Definitions:

- $V_{IN(MIN)}$ = Minimum Input Voltage
- $V_{IN(MAX)}$ = Maximum Input Voltage
- V_{OUT} = Output Voltage
- I_{OUT} = Output Current of Converter
- f = Switching Frequency
- DC_{MAX} = Power Switch Duty Cycle at $V_{IN(MIN)}$
- V_{CSPN} = Current Limit Voltage at DC_{MAX}

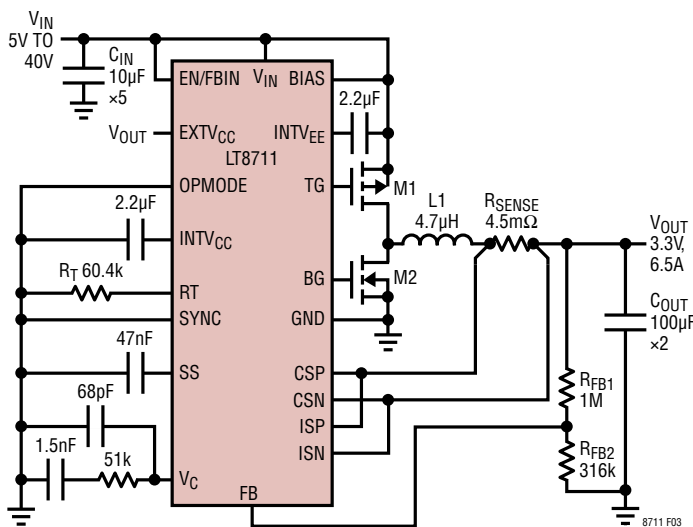

ADDITIONAL 470µF, 6.3V ELECTROLYTIC CAP ON V_{OUT}
47µF, 50V ELECTROLYTIC CAP ON V_{IN}

Figure 3. Buck Converter—The Component Values Given Are Typical Values for a 400kHz, 5V–40V to 3.3V/6.5A Buck

Table 1. Buck Design Equations

	Parameters/Equations
Step 1: Inputs	Pick V_{IN} , V_{OUT} , I_{OUT} , and f to calculate equations below.
Step 2: DC_{MAX}	$DC_{MAX} \equiv \frac{V_{OUT}}{V_{IN(MIN)}}$
Step 3: V_{CSPN}	See <i>Max Current Limit vs Duty Cycle</i> plot in Typical Performance Characteristics to find V_{CSPN} at DC_{MAX} .
Step 4: R_{SENSE}	$R_{SENSE} \leq 0.75 \cdot \frac{V_{CSPN}}{I_{OUT}}$
Step 5: L	$L_{TYP} = \frac{R_{SENSE} \cdot (V_{IN(MIN)} - V_{OUT})}{12.5m \cdot f} \cdot \frac{V_{OUT}}{V_{IN(MIN)}}$ $L_{MIN} = \frac{R_{SENSE} \cdot V_{IN(MIN)}}{40m \cdot f} \cdot \frac{2V_{OUT} - V_{IN(MIN)}}{V_{OUT}}$ $L_{MAX} = \frac{R_{SENSE} \cdot (V_{IN(MIN)} - V_{OUT})}{2.5m \cdot f} \cdot \frac{V_{OUT}}{V_{IN(MIN)}}$ <ul style="list-style-type: none"> • Solve equations 1 to 4 for a range of L values. • The minimum value of the L range is the higher of L_{TYP} and L_{MIN}.
Step 6: C_{OUT}	$C_{OUT} \geq \frac{1 - DC_{MIN}}{8 \cdot L \cdot f^2 \cdot 0.005}$
Step 7: C_{IN}	$C_{IN} \geq \frac{I_{OUT} \cdot DC_{MAX}}{f \cdot \Delta V_{IN}}$ <p>ΔV_{IN} is acceptable maximum input ripple voltage.</p>
Step 8: R_{FB1}/R_{FB2}	$R_{FB1} = \left(\frac{V_{OUT}}{0.8V} - 1 \right) \cdot R_{FB2}$
Step 9: R_T	$R_T = \frac{25000}{f}$ — 2: f is in kHz and R_T is in kΩ

NOTE: The final values for C_{OUT} and C_{IN} may deviate from the above equations in order to obtain desired load transient performance for a particular application. The C_{OUT} and C_{IN} equations assume zero ESR, so increase the capacitance accordingly based on the combined ESR.

APPLICATIONS INFORMATION

BOOST CONVERTER COMPONENT SELECTION

The LT8711 can be configured as a boost converter as in Figure 4.

For a desired output current and output voltage over a given input voltage range, Table 2 is a step-by-step set of equations to calculate component values for the LT8711 when operating as a boost converter. Refer to more detail in this section and the Appendix for further information on the design equations presented in Table 2.

Variable Definitions:

- $V_{IN(MIN)}$ = Minimum Input Voltage
- $V_{IN(MAX)}$ = Maximum Input Voltage
- V_{OUT} = Output Voltage
- I_{OUT} = Output Current of Converter
- f = Switching Frequency
- DC_{MAX} = Power Switch Duty Cycle at $V_{IN(MIN)}$
- V_{CSPN} = Current Limit Voltage at DC_{MAX}

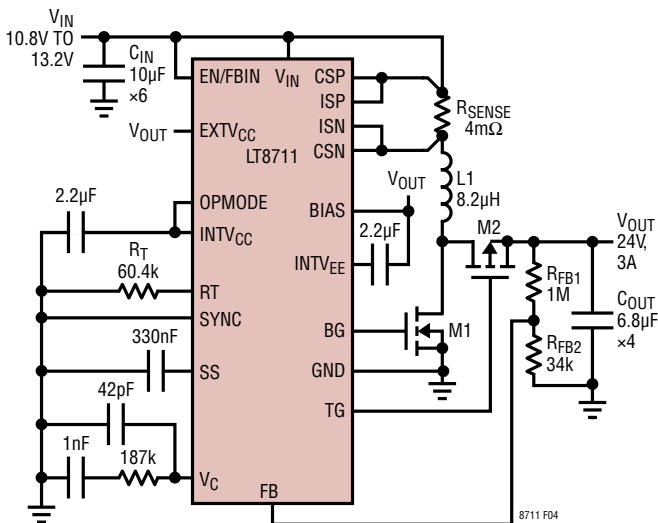

ADDITIONAL 270μF, 50V ELECTROLYTIC CAP ON V_{OUT}
47μF, 50V ELECTROLYTIC CAP ON V_{IN}

Figure 4. Boost Converter—The Component Values Given are Typical Values for a 400kHz, 12V to 24V/3A Boost

Table 2. Boost Design Equations

	Parameters/Equations
Step 1: Inputs	Pick V_{IN} , V_{OUT} , I_{OUT} , and f to calculate equations below.
Step 2: DC_{MAX}	$DC_{MAX} \cong 1 - \frac{V_{IN(MIN)}}{V_{OUT}}$
Step 3: V_{CSPN}	See <i>Max Current Limit vs Duty Cycle</i> plot in Typical Performance Characteristics to find V_{CSPN} at DC_{MAX} .
Step 4: R_{SENSE}	$R_{SENSE} \leq 0.63 \cdot \frac{V_{CSPN}}{I_{OUT}} (1 - DC_{MAX})$
Step 5: L	$L_{TYP} = \frac{R_{SENSE} \cdot V_{IN(MIN)}}{12.5m \cdot f} \cdot \left(1 - \frac{V_{IN(MIN)}}{V_{OUT}}\right)$ $L_{MIN} = \frac{R_{SENSE} \cdot V_{OUT}}{40m \cdot f} \cdot \left(1 - \frac{V_{IN(MIN)}}{V_{OUT} - V_{IN(MIN)}}\right)$ $L_{MAX1} = \frac{R_{SENSE} \cdot V_{IN(MIN)}}{5m \cdot f} \cdot \left(1 - \frac{V_{IN(MIN)}}{V_{OUT}}\right)$ $L_{MAX2} = \frac{R_{SENSE} \cdot V_{IN(MAX)}}{5m \cdot f} \cdot \left(1 - \frac{V_{IN(MAX)}}{V_{OUT}}\right)$ <ul style="list-style-type: none"> • Solve equations 1 to 4 for a range of L values. • The minimum value of the L range is the higher of L_{TYP} and L_{MIN}. The maximum of the L value range is the lower of L_{MAX}.
Step 6: C_{OUT}	$C_{OUT} \geq \frac{I_{OUT} \cdot DC_{MAX}}{f \cdot 0.005 \cdot V_{OUT}}$
Step 7: C_{IN}	$C_{IN} \geq \frac{DC_{MAX}}{8 \cdot L \cdot f^2 \cdot 0.005}$
Step 8: R_{FB1}/R_{FB2}	$R_{FB1} = \left(\frac{V_{OUT}}{0.8V} - 1\right) \cdot R_{FB2}$
Step 9: R_T	$R_T = \frac{25000}{f} - 2$: f is in kHz and R_T is in kΩ

NOTE: The final values for C_{OUT} and C_{IN} may deviate from the above equations in order to obtain desired load transient performance for a particular application. The C_{OUT} and C_{IN} equations assume zero ESR, so increase the capacitance accordingly based on the combined ESR.

APPLICATIONS INFORMATION

SEPIC CONVERTER COMPONENT SELECTION

The LT8711 can be configured as a SEPIC converter as in Figure 5.

For a desired output current and output voltage over a given input voltage range, Table 3 is a step-by-step set of equations to calculate component values for the LT8711 when operating as a SEPIC converter. Refer to more detail in this section and the Appendix for further information on the design equations presented in Table 3.

Variable Definitions:

- $V_{IN(MIN)}$ = Minimum Input Voltage
- $V_{IN(MAX)}$ = Maximum Input Voltage
- V_{OUT} = Output Voltage
- I_{OUT} = Output Current of Converter
- f = Switching Frequency
- DC_{MAX} = Power Switch Duty Cycle at $V_{IN(MIN)}$
- V_{CSPN} = Current Limit Voltage at DC_{MAX}

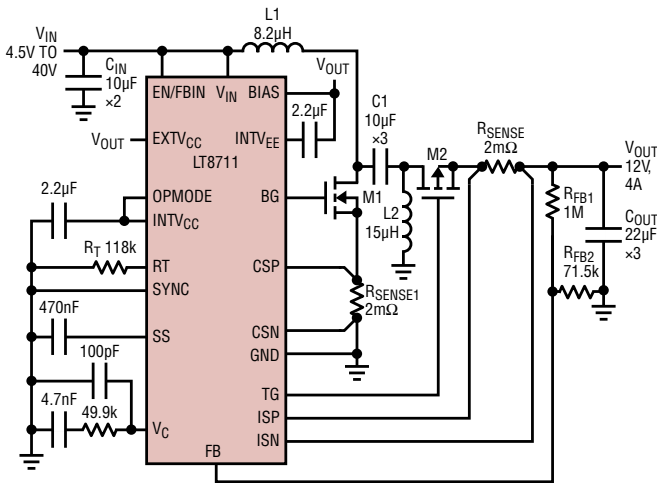

ADDITIONAL 270µF, 25V ELECTROLYTIC CAP ON V_{OUT}
56µF, 50V ELECTROLYTIC CAP ON V_{IN}

Figure 5. SEPIC Converter—The Component Values Given Are Typical Values for a 200kHz, 4.5V–40V to 12V/4A SEPIC

Table 3. SEPIC Design Equations

	Parameters/Equations
Step 1: Inputs	Pick V_{IN} , V_{OUT} , I_{OUT} , and f to calculate equations below.
Step 2: DC_{MAX}	$DC_{MAX} \equiv \frac{V_{OUT}}{V_{IN(MIN)} + V_{OUT}}$
Step 3: V_{CSPN}	See <i>Max Current Limit vs Duty Cycle</i> plot in Typical Performance Characteristics to find V_{CSPN} at DC_{MAX} .
Step 4: R_{SENSE}	$R_{SENSE} \leq 0.63 \cdot \frac{V_{CSPN} (1 - DC_{MAX})}{I_{OUT}}$ $R_{SENSE1} = R_{SENSE2} = R_{SENSE}$
Step 5: L	$L_{TYP} = \frac{R_{SENSE} \cdot V_{OUT}}{12.5m \cdot f} \cdot \frac{V_{IN(MIN)}}{V_{IN(MIN)} + V_{OUT}}$ $L_{MIN} = \frac{R_{SENSE} \cdot V_{OUT}}{40m \cdot f} \cdot \left(1 - \left(\frac{V_{IN(MIN)}}{V_{OUT}} \right)^2 \right)$ $L_{MAX} = \frac{R_{SENSE} \cdot V_{OUT}}{5m \cdot f} \cdot \frac{V_{IN(MIN)}}{V_{IN(MIN)} + V_{OUT}}$ <ul style="list-style-type: none"> • Solve equations 1 to 4 for a range of L values. • The minimum value of the L range is the higher of L_{TYP} and L_{MIN}. The maximum of the L value range is the lower of L_{MAX}. • $L = L1 = L2$ for coupled inductors. • $L = L1 \parallel L2$ for uncoupled inductors.
Step 6: C1	$C1 \geq 10\mu F$ (Typical); $V_{RATING} > V_{IN}$
Step 7: C_{OUT}	$C_{OUT} \geq \frac{I_{OUT} \cdot DC_{MAX}}{f \cdot 0.005 \cdot V_{OUT}}$
Step 8: C_{IN}	$C_{IN} \geq \frac{DC_{MAX}}{8 \cdot L \cdot f^2 \cdot 0.005}$
Step 9: R_{FB1}/R_{FB2}	$R_{FB1} = \left(\frac{V_{OUT}}{0.8V} - 1 \right) \cdot R_{FB2}$
Step 10: R_T	$R_T = \frac{25000}{f} - 2$ - f is in kHz and R_T is in $k\Omega$

NOTE: The final values for C_{OUT} and C_{IN} may deviate from the above equations in order to obtain desired load transient performance for a particular application. The C_{OUT} and C_{IN} equations assume zero ESR, so increase the capacitance accordingly based on the combined ESR.

APPLICATIONS INFORMATION

ZETA CONVERTER COMPONENT SELECTION

The LT8711 can be configured as a ZETA converter as in Figure 6.

For a desired output current and output voltage over a given input voltage range, Table 4 is a step-by-step set of equations to calculate component values for the LT8711 when operating as a ZETA converter. Refer to more detail in this section and the Appendix for further information on the design equations presented in Table 4.

Variable Definitions:

- $V_{IN(MIN)}$ = Minimum Input Voltage
- $V_{IN(MAX)}$ = Maximum Input Voltage
- V_{OUT} = Output Voltage
- I_{OUT} = Output Current of Converter
- f = Switching Frequency
- DC_{MAX} = Power Switch Duty Cycle at $V_{IN(MIN)}$
- V_{CSPN} = Current Limit Voltage at DC_{MAX}

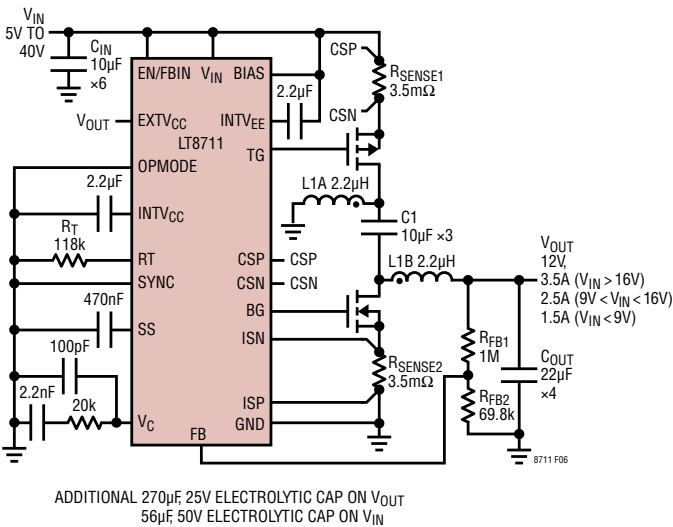

Figure 6. ZETA Converter—The Component Values Given Are Typical Values for a 200kHz, 5V–40V to 12V/3.5A ZETA

Table 4. ZETA Design Equations

	Parameters/Equations
Step 1: Inputs	Pick V_{IN} , V_{OUT} , I_{OUT} , and f to calculate equations below.
Step 2: DC_{MAX}	$DC_{MAX} \equiv \frac{V_{OUT}}{V_{IN(MIN)} + V_{OUT}}$
Step 3: V_{CSPN}	See <i>Max Current Limit vs Duty Cycle</i> plot in Typical Performance Characteristics to find V_{CSPN} at DC_{MAX} .
Step 4: R_{SENSE}	$R_{SENSE} \leq 0.63 \cdot \frac{V_{CSPN} (1 - DC_{MAX})}{I_{OUT}}$ $R_{SENSE1} = R_{SENSE2} = R_{SENSE}$
Step 5: L	$L_{TYP} = \frac{R_{SENSE} \cdot V_{OUT}}{12.5m \cdot f} \cdot \frac{V_{IN(MIN)}}{V_{IN(MIN)} + V_{OUT}}$ $L_{MIN} = \frac{R_{SENSE} \cdot V_{OUT}}{40m \cdot f} \cdot \left(1 - \left(\frac{V_{IN(MIN)}}{V_{OUT}} \right)^2 \right)$ $L_{MAX} = \frac{R_{SENSE} \cdot V_{OUT}}{5m \cdot f} \cdot \frac{V_{IN(MIN)}}{V_{IN(MIN)} + V_{OUT}}$ <ul style="list-style-type: none"> • Solve equations 1 to 4 for a range of L values. • The minimum value of the L range is the higher of L_{TYP} and L_{MIN}. The maximum of the L value range is the lower of L_{MAX}. • $L = L1 = L2$ for coupled inductors. • $L = L1 L2$ for uncoupled inductors.
Step 6: $C1$	$C1 \geq 10\mu F$ (Typical); $V_{RATING} > V_{IN}$
Step 7: C_{OUT}	$C_{OUT} \geq \frac{I_{OUT} \cdot DC_{MAX}}{f \cdot 0.005 \cdot V_{OUT}}$
Step 8: C_{IN}	$C_{IN} \geq \frac{DC_{MAX}}{8 \cdot L \cdot f^2 \cdot 0.005}$
Step 9: R_{FB1}/R_{FB2}	$R_{FB1} = \left(\frac{V_{OUT}}{0.8V} - 1 \right) \cdot R_{FB2}$
Step 10: R_T	$R_T = \frac{25000}{f} - 2$; f is in kHz and R_T is in k Ω

NOTE: The final values for C_{OUT} and C_{IN} may deviate from the above equations in order to obtain desired load transient performance for a particular application. The C_{OUT} and C_{IN} equations assume zero ESR, so increase the capacitance accordingly based on the combined ESR.

APPLICATIONS INFORMATION

BUCK-BOOST CONVERTER COMPONENT SELECTION

The LT8711 can be configured as a buck-boost converter as in Figure 7.

For a desired output current and output voltage over a given input voltage range, Table 5 is a step-by-step set of equations to calculate component values for the LT8711 when operating as a buck-boost converter. Refer to more detail in this section and the Appendix for further information on the design equations presented in Table 5.

Variable Definitions:

- $V_{IN(MIN)}$ = Minimum Input Voltage
- $V_{IN(MAX)}$ = Maximum Input Voltage
- V_{OUT} = Output Voltage
- I_{OUT} = Output Current of Converter
- f = Switching Frequency
- DC_{MAX} = Power Switch Duty Cycle at $V_{IN(MIN)}$
- V_{CSPN} = Current Limit Voltage at DC_{MAX}

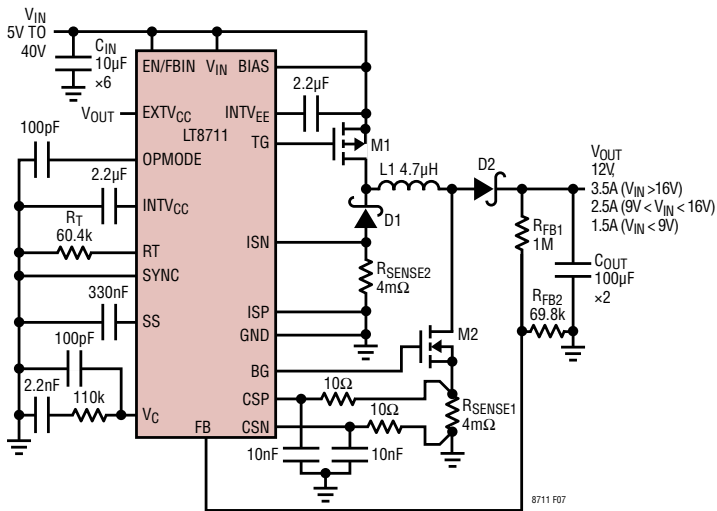

Figure 7. Buck-Boost Converter—The Component Values Given Are Typical Values for a 400kHz, 5V–40V to 12V/2.5A Buck-Boost

Table 5. Buck-Boost Design Equations

	Parameters/Equations
Step 1: Inputs	Pick V_{IN} , V_{OUT} , I_{OUT} , and f to calculate equations below.
Step 2: DC_{MAX}	$DC_{MAX} \equiv \frac{V_{OUT}}{V_{IN(MIN)} + V_{OUT}}$
Step 3: V_{CSPN}	See <i>Max Current Limit vs Duty Cycle</i> plot in Typical Performance Characteristics to find V_{CSPN} at DC_{MAX} .
Step 4: R_{SENSE}	$R_{SENSE} \leq 0.63 \cdot \frac{V_{CSPN} (1 - DC_{MAX})}{I_{OUT}}$ $R_{SENSE1} = R_{SENSE2} = R_{SENSE}$
Step 5: L	$L_{TYP} = \frac{R_{SENSE} \cdot V_{OUT}}{12.5m \cdot f} \cdot \frac{V_{IN(MIN)}}{V_{IN(MIN)} + V_{OUT}}$ $L_{MIN} = \frac{R_{SENSE} \cdot V_{OUT}}{40m \cdot f} \cdot \left(1 - \left(\frac{V_{IN(MIN)}}{V_{OUT}} \right)^2 \right)$ $L_{MAX} = \frac{R_{SENSE} \cdot V_{OUT}}{5m \cdot f} \cdot \frac{V_{IN(MIN)}}{V_{IN(MIN)} + V_{OUT}}$ <ul style="list-style-type: none"> • Solve equations 1 to 4 for a range of L values. • The minimum value of the L range is the higher of L_{TYP} and L_{MIN}. The maximum of the L value range is the lower of L_{MAX}.
Step 6: C_{OUT}	$C_{OUT} \geq \frac{I_{OUT} \cdot DC_{MAX}}{f \cdot 0.005 \cdot V_{OUT}}$
Step 7: C_{IN}	$C_{IN} \geq \frac{DC_{MAX}}{8 \cdot L \cdot f^2 \cdot 0.005}$
Step 8: R_{FB1}/R_{FB2}	$R_{FB1} = \left(\frac{V_{OUT}}{0.8V} - 1 \right) \cdot R_{FB2}$
Step 9: R_T	$R_T = \frac{25000}{f} - 2$ — 2: f is in kHz and R_T is in k Ω

NOTE: The final values for C_{OUT} and C_{IN} may deviate from the above equations in order to obtain desired load transient performance for a particular application. The C_{OUT} and C_{IN} equations assume zero ESR, so increase the capacitance accordingly based on the combined ESR.

APPLICATIONS INFORMATION

SETTING THE OUTPUT VOLTAGE REGULATION

The LT8711 output voltage is set by a resistor divider between V_{OUT} , FB, and GND.

$$V_{OUT} = 0.8V \cdot \left(1 + \frac{R_{FB1}}{R_{FB2}} \right)$$

where R_{FB1} and R_{FB2} are shown in the Block Diagram.

See the Electrical Characteristics for tolerances on the FB regulation voltage.

SETTING THE INPUT VOLTAGE REGULATION OR UNDERVOLTAGE LOCKOUT

By connecting a resistor divider between V_{IN} , EN/FBIN, and GND, the EN/FBIN pin provides a means to regulate the input voltage or to create an undervoltage lockout function. Referring to error amplifier EA2 in the block diagram, when EN/FBIN is lower than the 1.2V reference, V_C is pulled low. For example, if V_{IN} is provided by a relatively high impedance source (e.g. a solar panel) and the current draw pulls V_{IN} below a preset limit, V_C will be reduced, thus reducing current draw from the input supply and limiting the input voltage drop.

To set the minimum or regulated input voltage use:

$$V_{IN(MIN-REG)} = 1.2V \cdot \left(1 + \frac{R_{IN1}}{R_{IN2}} \right)$$

where R_{IN1} and R_{IN2} are shown in the Block Diagram.

Temperature Dependent Output Voltage Using NTC Resistor

It may be desirable to regulate the converter's output based on the ambient temperature. The $INTV_{CC}$ LDO regulated voltage is $5.0V \pm 4\%$ (see Electrical Characteristics), and a negative temperature coefficient (NTC) resistor can be used to sum into the FB pin to create an output voltage that decreases with temperature. See Figure 8 for the necessary connections.

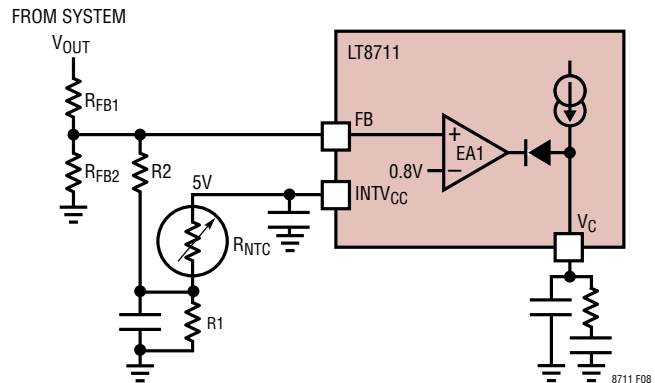

Figure 8. Temperature Dependent Output Using an NTC Resistor Divider

The FB voltage regulates to 0.8V (typical). For an accurate room temperature output voltage, size the resistor divider off the $INTV_{CC}$ pin to give 0.8V such that the current through R_2 is ~ 0 at room temperature. Choose $R_{NTC(25)} \leq 10k\Omega$ and use the equations below to calculate R_1 , R_{FB1} , and V_{OUT} at room temperature and R_{FB2} for a desired V_{OUT} change over temperature.

$$R_1 = R_{NTC(25)} \frac{0.8V}{5.0V - 0.8V}$$

$$V_{OUT} \cong 0.8V + \frac{R_{FB1}}{R_2}$$

$$\cdot \left(0.8V - 5.0V \cdot \frac{R_1}{R_1 + R_{NTC(25)}} \right) + 0.8V \cdot \frac{R_{FB1}}{R_{FB2}}$$

$$R_{NTC} = R_{NTC(25)} \cdot e^{\beta \cdot \left(\frac{1}{T} - \frac{1}{T_{25}} \right)}$$

$$\Delta V_{OUT} = -5.0V \cdot \frac{R_{FB1}}{R_2} \cdot R_1$$

$$\cdot \left(\frac{1}{R_1 + R_{NTC(T(MAX))}} - \frac{1}{R_1 + R_{NTC(T(MIN))}} \right)$$

$$R_2 = \frac{-5.0V}{\Delta V_{OUT}} \cdot R_{FB1} \cdot R_1$$

$$\cdot \left(\frac{1}{R_1 + R_{NTC(T(MAX))}} - \frac{1}{R_1 + R_{NTC(T(MIN))}} \right)$$

APPLICATIONS INFORMATION

where:

- $R_{NTC(25)}$ = Resistance of the NTC resistor at 25°C
- β = Material-specific constant of NTC resistor. Specified at two temperatures such as $\beta_{25/85}$. If more than two β s are specified, use the most appropriate for the application.
- T = Absolute temperature in Kelvin
- T_{25} = Room temperature in Kelvin (298.15K)

SWITCH CURRENT LIMIT (CSP-CSN CURRENT SENSING)

The external current sense resistor (R_{SENSE}) sets the maximum peak current. The maximum voltage across R_{SENSE} is 50mV (typical) at very low switch duty cycles, and then slope compensation decreases the current limit as the duty cycle increases (see the *Max Current Limit vs Duty Cycle (CSP-CSN)* plot in the Typical Performance Characteristics). The equation below gives the switch current limit for a given duty cycle and current sense resistor (find V_{CSPN} at the operating duty cycle in the plot mentioned).

$$I_{SW(LIMIT)} = \frac{V_{CSPN}}{R_{SENSE}}$$

To provide a desired load current for any given application, R_{SENSE} must be sized appropriately. The equation below calculates R_{SENSE} for a desired output current:

$$R_{SENSE} \leq 0.74 \cdot \eta \cdot \frac{V_{CSPN}}{I_{OUT}} \cdot (1 - DC_{MAX}) \cdot \left(1 - \frac{i_{RIPPLE}}{2}\right)$$

- η = Converter efficiency (assume ~90%)
- V_{CSPN} = Max current limit voltage (see *Max Current Limit vs Duty Cycle (CSP-CSN)* plot in the Typical Performance Characteristics)
- I_{OUT} = Converter load current
- DC_{MAX} = Switching duty cycle at minimum V_{IN} (see Power Switch Duty Cycle in Appendix)
- i_{RIPPLE} = Peak-to-peak inductor ripple current percentage at minimum V_{IN} (recommended to use 25%)

ISP-ISN CURRENT SENSING

CSP/CSN current sensing is used in switching regulator peak current control.

ISP/ISN current sensing monitors the current of the rectifier switch and helps protect the circuit from overload conditions.

The ISP-ISN circuitry delays switching if the rectifier switch current goes too high. This mechanism also protects the part during short-circuit and overload conditions by keeping the current through the inductor under control.

Let's see a buck mode example.

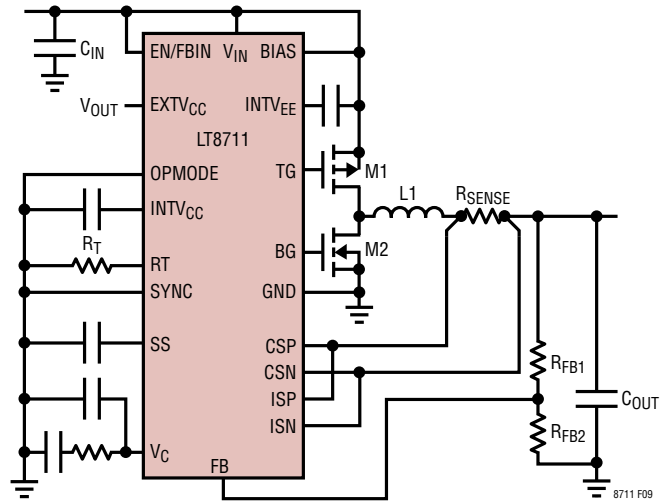

Figure 9. ISP-ISN Current Sensing Example

A potential controllability problem could occur under short-circuit conditions without rectifier switch current sensing. If the power supply output is short circuited, the feedback amplifier (EA) responds to the low output voltage by raising the control voltage, V_C , to its peak current limit value. Ideally, the top switch would be turned on, and then turned off as its current exceeded the value indicated by V_C . However, there is finite response time involved in both the current comparator and turnoff of the top switch. These result in a minimum on time, $t_{ON(MIN)}$. When combined with high V_{IN} , the potential exists for a loss of control.

APPLICATIONS INFORMATION

Expressed mathematically the requirement to maintain control is:

$$f \cdot t_{ON} \leq \frac{V_{R(SENSE)_L} + V_{DS_NMOS} + I \cdot R}{V_{IN}}$$

where:

f = switching frequency

t_{ON} = switch minimum on time

V_{R(SENSE)_L} = voltage drop on high side sense resistor

V_{DS_NMOS} = voltage drop on high side PMOS switch

V_{IN} = Input voltage

I • R = inductor I • R voltage drop

If this condition is not observed, the current will not be limited at I_{PK}, but will cycle-by-cycle ratchet up to some higher value. With rectifier switch current sensing, the current through the inductor would be controlled under the whole clock cycle. The switching will only resume once rectifier switch current has fallen below I_{PK}.

ISP-ISN current sensing is also used in reverse current detecting for DCM operation.

CURRENT SENSE FILTERING

Certain applications may require filtering of the current sense signals due to excessive switching noise that can appear across R_{SENSE1} and/or R_{SENSE2}. Higher operating voltages, higher inductor current, higher values of R_{SENSE}, and more capacitive MOSFETs will all contribute additional noise across R_{SENSE} when MOSFETs transition. The CSP/CSN and/or the ISP/ISN sense signals can be filtered by adding one of the RC networks shown in Figure 10. The filter shown in Figure 10a filters out differential noise, whereas the filter in Figure 10b filters out the differential and common mode noise at the expense of an additional capacitor and approximately twice the capacitance value. It is recommended to Kelvin tie the ground connection directly to the paddle of the LT8711 if using the filter in Figure 10b. The filter network should be placed as close as possible to the LT8711. Resistors greater than 10Ω should be avoided as this can increase the offset voltages at the CSP/CSN and ISP/ISN pins.

Table 6. CSP/CSN, ISP/ISN Bias Current:

	V _{CM} = 0V	V _{CM} > 3V
I_CSP (typ)	0μA	4μA ~ 25μA
I_CSN (typ)	-4μA ~ -25μA	110μA
I_ISP (typ)	0μA	4μA ~ 25μA
I_ISN (typ)	-4μA ~ -25μA	220μA

When V_{CM} changes from 0V to 3V, bias current changes gradually from low side values to high side values as shown in Table 6.

CSN/ISN bias current at high side is proportional to temperature (see the *CSN/ISN Bias Current vs Temperature* plots in the Typical Performance Characteristics).

Positive bias currents flow into the pins. Negative bias currents flow out of the pins.

Bias current of 4μA ~ 25μA and -4μA ~ -25μA in the table changes according to the V_C voltage. 4μA (-4μA) corresponds to the minimum V_C voltage. 25μA (-25μA) corresponds to the maximum V_C voltage.

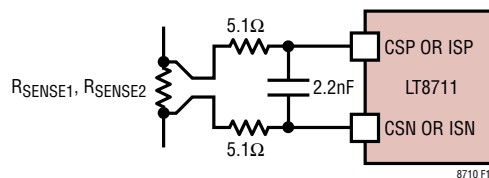

Figure 10a. Differential RC Filter on CSP/CSN and/or ISP/ISN Pins

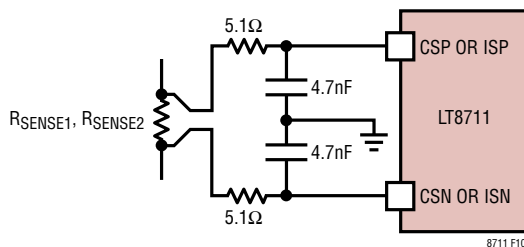

Figure 10b. Differential and Common Mode RC Filter on CSP/CSN and/or ISP/ISN Pins

SWITCHING FREQUENCY

The LT8711 uses a constant frequency architecture whose frequency can be between 100kHz and 750kHz. The frequency can be set using the internal oscillator or can be synchronized to an external clock source. Selection of

APPLICATIONS INFORMATION

the switching frequency is a trade-off between efficiency and component size. Low frequency operation increases efficiency by reducing MOSFET switching losses, but requires larger inductance and/or capacitance to maintain low output ripple voltage. For high power applications, consider operating at lower frequencies to minimize MOSFET heating from switching losses. The switching frequency can be set by placing an appropriate resistor from the RT pin to ground and tying the SYNC pin low. The frequency can also be synchronized to an external clock source driven into the SYNC pin. The following sections provide more details.

Oscillator Timing Resistor (RT)

The operating frequency of the LT8711 can be set by the internal free-running oscillator. When the SYNC pin is driven low (< 0.4V), the frequency of operation is set by a resistor from the RT pin to ground. The oscillator frequency is calculated using the following formula:

$$f = \frac{25000}{R_T + 2}$$

where f is in kHz and R_T is in k Ω . Conversely, R_T can be calculated from the desired frequency using:

$$R_T = \frac{25000}{f} - 2$$

Clock Synchronization

An external source can set the operating frequency of the LT8711 by providing a digital clock signal into the SYNC pin (RT resistor still required). The LT8711 will operate at the SYNC clock frequency. The LT8711 will revert to its internal free-running oscillator clock when the SYNC pin is driven below 0.4V for a few free-running clock periods. The LT8711 will operate in FCM mode with internal free-running oscillator clock if driving SYNC high for an extended period of time.

The duty cycle of the SYNC signal must be between 20% and 80% for proper operation. Also, the frequency of the SYNC signal must meet the following two criteria:

1. SYNC may not toggle outside the frequency range of 140kHz to 750kHz unless it is stopped below 0.4V to enable the free-running oscillator.

2. The SYNC frequency can always be higher than the free-running oscillator frequency (as set by the R_T resistor), f_{OSC} , but should not be less than 20% below f_{OSC} .

LDO REGULATORS

The LT8711 has two linear regulators to run the BG and TG gate drivers. The INTV_{CC} LDO regulates 5V (typical) above ground, and the INTV_{EE} regulator regulates 5.15V (typical) below the BIAS pin.

INTV_{CC} LDO Regulator

The INTV_{CC} LDO is used as the top rail for the BG gate driver. An external capacitor greater than 2.2 μ F must be placed from the INTV_{CC} pin to ground. The capacitor should have low ESR, such as a ceramic capacitor.

The INTV_{CC} LDO can run off V_{IN} or EXT V_{CC} and will intelligently select to run off the best rail for minimizing chip power loss, but at the same time, select the proper input for maintaining INTV_{CC} as close to 5V as possible. For example, Figure 11 is a plot that shows how V_{IN} or EXT V_{CC} is selected.

Overcurrent protection circuitry typically limits the maximum current draw from the LDO to ~50mA. If the selected input voltage is greater than 24V (typical), then the current limit of the LDO reduces linearly with input voltage to limit the maximum power in the INTV_{CC} pass device. See the INTV_{CC} Current Limit vs V_{IN} or EXT V_{CC} plot in the Typical Performance Characteristics.

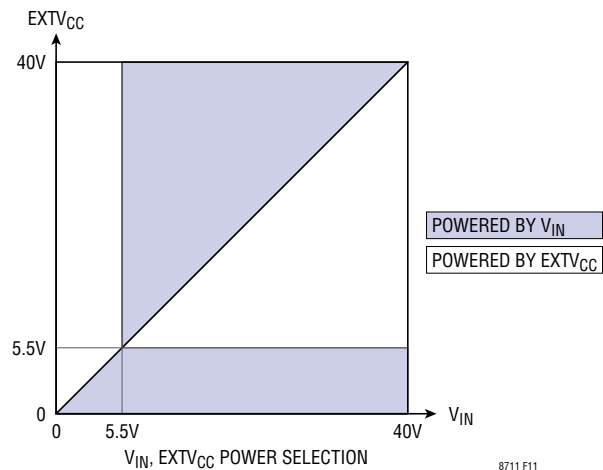

Figure 11. INTV_{CC} Input Voltage Selection

APPLICATIONS INFORMATION

Power dissipated in the $INTV_{CC}$ LDO should be minimized to improve efficiency and prevent overheating of the LT8711. The current limit reduction with input voltage circuit helps prevent the part from overheating, but these guidelines should be followed. The maximum current drawn through the $INTV_{CC}$ LDO occurs under the following conditions:

1. Large (capacitive) MOSFETs being driven at high frequencies
2. The converter's switch voltage (V_{IN} for BUCK, V_{OUT} for BOOST and BUCK-BOOST, $V_{IN} + V_{OUT}$ for SEPIC converters) is high, thus requiring more charge to turn the MOSFET gates on and off.

In general, use appropriately sized MOSFETs and lower the switching frequency for higher voltage applications to keep the $INTV_{CC}$ current at a minimum.

$INTV_{EE}$ LDO Regulator

The BIAS and $INTV_{EE}$ voltages are used for the top and bottom rails of the TG gate driver respectively. An external capacitor greater than $2.2\mu\text{F}$ must be placed between the BIAS and $INTV_{EE}$ pins. The capacitor should have low ESR, such as ceramic capacitor.

Overcurrent protection circuitry typically limits the maximum current draw from the regulator to $\sim 80\text{mA}$. If the BIAS voltage is greater than 15V (typical), then the current limit of the regulator reduces linearly with input voltage to limit the maximum power in the $INTV_{EE}$ pass device. See the *$INTV_{EE}$ Current Limit vs BIAS* plot in the Typical Performance Characteristics.

The same thermal guidelines from the $INTV_{CC}$ LDO Regulator section apply to the $INTV_{EE}$ regulator as well.

NONSYNCHRONOUS CONVERTER

It may be desirable in some applications to replace the external PFET with a Schottky diode to make a nonsynchronous converter. One example would be a high output voltage application because the voltage drop across the rectifier has a small effect on the efficiency of the converter. In fact, for high output voltage applications, replacing the PFET with a Schottky may result in higher efficiency

because the LT8711 doesn't have to supply gate drive to the PFET. Figure 12 shows the recommended connections for using the LT8711 as a nonsynchronous boost converter, however the same concept can be used for any other converter topology.

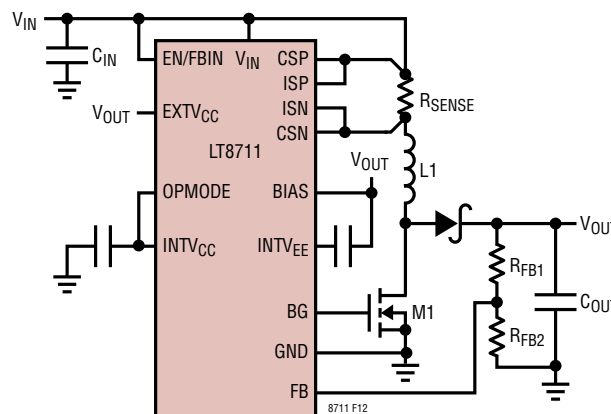

Figure 12. Simplified Schematic of a Nonsynchronous Boost Converter

LAYOUT GUIDELINES FOR BUCK, BOOST, SEPIC, ZETA AND BUCK-BOOST TOPOLOGIES

General Layout Guidelines

- To optimize thermal performance, solder the exposed pad of the LT8711 to the ground plane with multiple vias around the pad connecting to additional ground planes.
- High speed switching path (see specific topology below for more information) must be kept as short as possible.
- The FB, V_C and RT components should be placed as close to the LT8711 as possible, while being far away as practically possible from switching nodes. The ground for these components should be separated from the switch current path.
- Place bypass capacitors for the V_{IN} and $EXTV_{CC}$ pins ($1\mu\text{F}$ or greater) as close as possible to the LT8711.
- Place bypass capacitors for the $INTV_{CC}$ and $INTV_{EE}$ (between BIAS and $INTV_{EE}$) pins ($2.2\mu\text{F}$ or greater) as close as possible to the LT8711.

APPLICATIONS INFORMATION

- The load should connect directly to the positive and negative terminals of the output capacitor for best load regulation.

BUCK Topology Specific Layout Guidelines

- Keep length of loop (high speed switching path) governing MN, MP, C_{IN} , and ground return as short as possible to minimize parasitic inductive spikes at the switch node during switching.

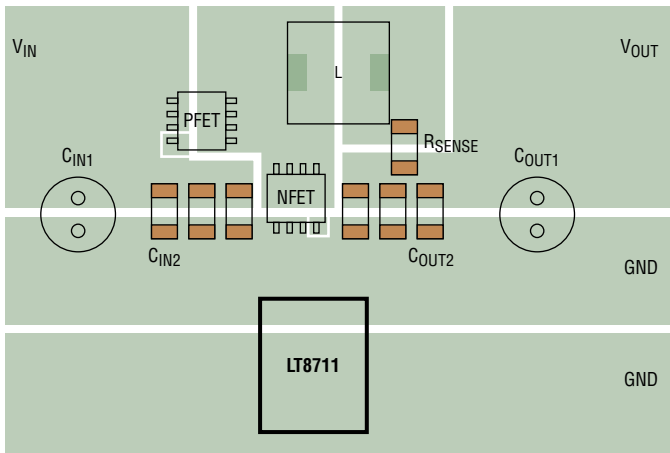

8711 F13

Figure 13. Suggested Component Placement for Buck Topology

Boost Topology Specific Layout Guidelines

- Keep length of loop (high speed switching path) governing MN, MP, C_{OUT} , and ground return as short as possible to minimize parasitic inductive spikes at the switch node during switching.

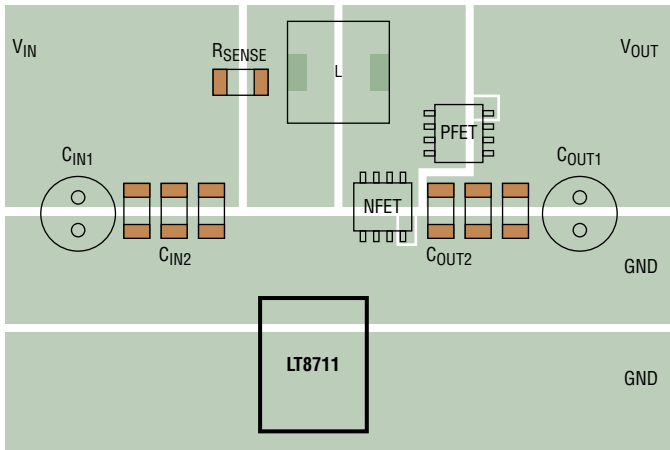

8711 F13

Figure 14. Suggested Component Placement for Boost Topology

SEPIC Topology Specific Layout Guidelines

- Keep length of loop (high speed switching path) governing R_{SENSE1} , MN, C1, MP, R_{SENSE2} , C_{OUT} , and ground return as short as possible to minimize parasitic inductive spikes at the switch node during switching.

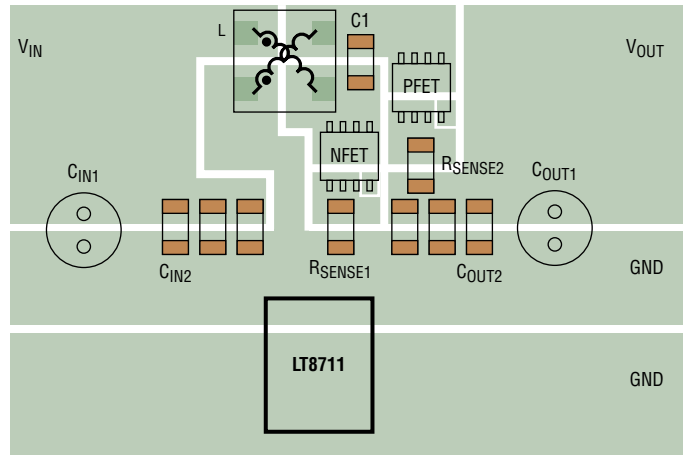

8711 F15

Figure 15. Suggested Component Placement for SEPIC Topology

ZETA Topology Specific Layout Guidelines

- Keep length of loop (high speed switching path) governing R_{SENSE1} , MN, C1, MP, R_{SENSE2} , C_{IN} , and ground return as short as possible to minimize parasitic inductive spikes at the switch node during switching.

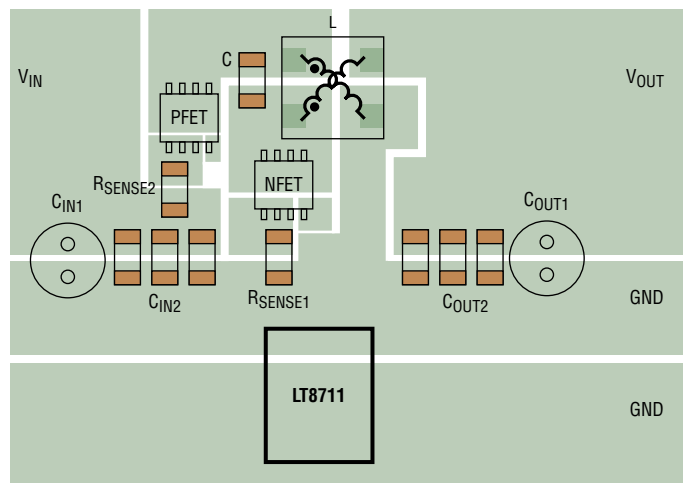

8711 F16

Figure 16. Suggested Component Placement for ZETA Topology

APPLICATIONS INFORMATION

Buck-Boost Topology Specific Layout Guidelines

- Keep length of loop (high speed switching path) governing R_{SENSE1} , DIO1, MP, C_{IN} , and ground return as short as possible to minimize parasitic inductive spikes at the switch node during switching.
- Keep length of loop (high speed switching path) governing R_{SENSE2} , MN, DIO2, C_{OUT} , and ground return as short as possible to minimize parasitic inductive spikes at the switch node during switching.

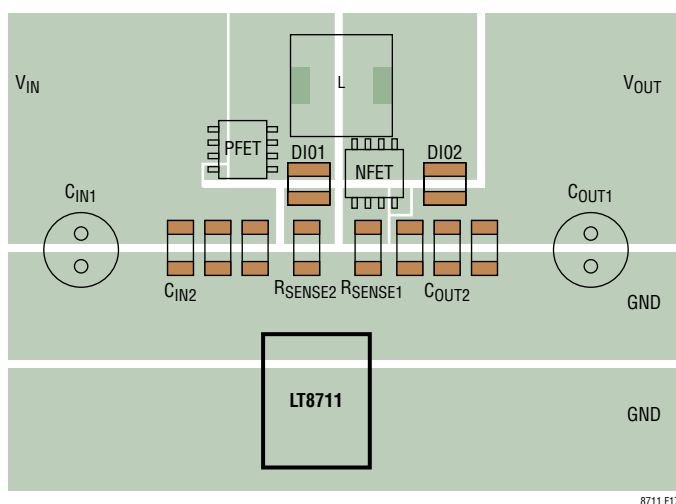

Figure 17. Suggested Component Placement for Buck-Boost Topology

Current Sense Resistor Layout Guidelines

- Route the CSP/CSN and ISP/ISN lines differentially (close together) from the chip to the current sense resistor as shown in Figure 17.
- Place the vias that connect the CSP/CSN and ISP/ISN lines directly at the terminals of the current sense resistor as shown in Figure 17.

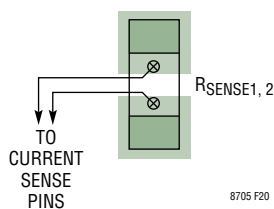

Figure 18. Suggested Routing and Connections of CSP/CSN and ISP/ISN Lines

THERMAL CONSIDERATIONS

Overview

The primary components on the board that consume the most power and produce the most heat are the power switches, MN and MP, the power inductor, the Schottky diodes in the nonsynchronous buck-boost converter and the LT8711 IC. It is imperative that a good thermal path be provided for these components to dissipate the heat generated within the packages. This can be accomplished by taking advantage of the thermal pads on the underside of the packages. It is recommended that multiple vias in the printed circuit board be used to conduct heat away from each of these components and into a copper plane with as much area as possible. For the case of the power switches, the copper area of the drain connections shouldn't be too big as to create a large EMI surface that can radiate noise around the board.

Power MOSFET Loss and Thermal Calculations

The LT8711 requires two external power MOSFETs, an NFET switch for the BG gate driver and a PFET switch for the TG gate driver. Important parameters for estimating the power dissipation in the MOSFETs are:

1. On-resistance ($R_{DS(ON)}$)
2. Gate-to-drain charge (Q_{GD})
3. PFET body diode forward voltage (V_{BD})
4. V_{DS} of the FETs during their Off-Time
5. Switch current (I_{SW})
6. Switching frequency (f)

The power loss in each power switch has a DC and AC term. The DC term is when the power switch is fully on, and the AC term is when the power switch is transitioning from on-off or off-on.

APPLICATIONS INFORMATION

The following applies for both the NFET and PFET power switches. Below are the equations for the power loss in MN and MP.

$$P_{\text{MOSFET}} = P_{I^2R} + P_{\text{SWITCHING}}$$

$$P_{\text{MN}} = I_N^2 \cdot R_{\text{DS(ON)}} + V_{\text{DS}} \cdot I_N \cdot f \cdot t_{\text{RF}} + P_{\text{RR-N}}$$

$$P_{\text{MP}} = I_P^2 \cdot R_{\text{DS(ON)}} + V_{\text{BD}} \cdot \left(I_{\text{PK}} + \frac{I_{\text{VY}}}{1.6} \right) \cdot f \cdot 140\text{ns} + P_{\text{RR-N}}$$

$$I_{\text{PK}} = I_{\text{SW}} + \frac{i_{\text{RIPPLE}}}{2}; I_{\text{VY}} = I_{\text{SW}} - \frac{i_{\text{RIPPLE}}}{2}$$

$$P_{\text{RR-N}} \approx \frac{V_{\text{DS}} \cdot I_{\text{RR}} \cdot t_{\text{RR}} \cdot f}{2}$$

$$P_{\text{RR-P}} \approx \frac{V_{\text{DS}} \cdot I_{\text{RR}} \cdot t_{\text{RR}} \cdot f}{2}$$

where:

- f = Switching Frequency
- I_N = NFET RMS Current
- I_P = PFET RMS Current
- t_{RF} = Average of the rise and fall times of the NFET's drain voltage
- I_{SW} = Average switch current during its on-time
- I_{PK} = Peak inductor current
- I_{VY} = Valley inductor current
- i_{RIPPLE} = Inductor ripple current
- DC = Switch duty cycle (see Power Switch Duty Cycle section in Appendix)
- V_{BD} = PFET body diode forward voltage at I_{SW}
- V_{DS} = Voltage across the FET when it's off.
- $P_{\text{RR-N}}$ = PFET body diode reverse recovery power loss in the NFET
- $P_{\text{RR-P}}$ = PFET body diode reverse recovery power loss in the PFET
- I_{RR} = Current needed to remove the PFET body diode charge
- t_{RR} = Reverse recovery time of PFET body diode

Typical values for t_{RF} are 10ns to 40ns depending on the MOSFET capacitance and drain voltage. In general, the lower the QGD of the MOSFET, the faster the rise and fall times of its drain voltage. For best calculations, measure the rise and fall times in the application.

PFET body diode reverse recovery power loss is dependent on many factors and can be difficult to quantify in an application. In general, this power loss increases with higher V_{DS} and/or higher switching frequency.

Chip Power and Thermal Calculations

Power dissipation in the LT8711 chip comes from three primary sources: INTV_{CC} and INTV_{EE} LDOs providing gate drive to the BG and TG pins and the chip quiescent current. The average current through each LDO is determined by the gate charge of the power switches, MN and MP, and the switching frequency. Below are the equations for calculating the chip power loss.

The INTV_{CC} LDO primarily supplies voltage for the BG gate driver. The BIAS and INTV_{EE} voltages supply the top and bottom rails of the TG gate driver respectively. The chip Q current comes from INTV_{CC} . Below are the chip power equations:

$$P_{\text{INTVCC_BG}} = Q_{\text{MN}} \cdot f \cdot V_{\text{SELECT}}$$

$$P_{\text{INTVCC_Q}} = 2\text{mA} \cdot V_{\text{SELECT}}$$

$$P_{\text{INTVEE}} = Q_{\text{MP}} \cdot f \cdot V_{\text{BIAS}}$$

where:

- f = Switching frequency
- Q_{MN} = Total gate charge of NFET power switch (MN)
- Q_{MP} = Total gate charge of PFET power switch (MP)
- V_{SELECT} = INTV_{CC} LDO selected input voltage, V_{IN} or EXTV_{CC} (see LDO Regulators section)

Thermal Lockout

If the die temperature reaches $\sim 165^\circ\text{C}$, the part will go into shutdown, so the power switches turn off and the soft-start capacitor will be discharged. The LT8711 will come out of shutdown when the die temperature drops by $\sim 5^\circ\text{C}$ (typical).

APPENDIX

POWER SWITCH DUTY CYCLE

The external power main switch (PFET in the Block Diagram) cannot remain off for 100% of each clock cycle, and will turn on for a minimum on time (MinOnTime) when in regulation. This MinOnTime governs the minimum allowable duty cycle given by:

$$DC_{MIN} = \frac{(\text{MinOnTime})}{T_P} \cdot 100\%$$

where TP is the clock period and MinOnTime (found in the Electrical Characteristics) is 100ns (typ).

The application should be designed such that the operating duty cycle is higher than DC_{MIN}.

Duty cycle equations for different topologies are given below.

For the Buck topology (see Figure 3):

$$DC_{BUCK} \cong \frac{V_{OUT}}{V_{IN}}$$

For the Boost topology (see Figure 4):

$$DC_{BOOST} \cong 1 - \frac{V_{IN}}{V_{OUT}}$$

For the SEPIC topology (see Figures 6):

$$DC_{SEPIC} \cong \frac{V_{OUT}}{V_{IN} + V_{OUT}}$$

For the ZETA topology (see Figures 7):

$$DC_{ZETA} \cong \frac{V_{OUT}}{V_{IN} + V_{OUT}}$$

For the Buck-Boost topology (see Figures 8):

$$DC_{BUCK-BOOST} \cong \frac{V_{OUT}}{V_{IN} + V_{OUT}}$$

INDUCTOR SELECTION

For high efficiency, choose inductors with high frequency core material, such as ferrite, to reduce core losses. Additionally, choose inductors with more volume for a given inductance. The inductor should have low DCR (copper-wire resistance) to reduce I²R losses, and must be able

to handle the peak inductor current without saturating. Note that in some applications, the current handling requirements of the inductor can be lower, such as in the SEPIC topology where each inductor carries a fraction of the total switch current. Molded chokes or chip inductors do not have enough core area to support peak inductor currents in the 5A to 15A range. To minimize radiated noise, use a toroidal or shielded inductor. See Table 7 for a list of inductor manufacturers.

Table 7. Inductor Manufacturers

Coilcraft	MSS1278, XAL1010, and MSD1278 Series	www.coilcraft.com
Cooper Bussmann	DRQ127, DR127, and HCM1104 Series	www.cooperbussmann.com
Vishay	IHLP Series	www.vishay.com
Würth	WE-DCT Series WE-CFWI Series	www.we-online.com

Minimum Inductance

Although there can be a trade-off with efficiency, it is often desirable to minimize board space by choosing smaller inductors. When choosing an inductor, there are two conditions that limit the minimum inductance; (1) providing adequate load current, and (2) avoidance of subharmonic oscillation.

Adequate Load Current

Small value inductors result in increased ripple currents and thus, due to the limited peak switch current, decrease the average current that can be provided to the load.

Avoiding Subharmonic Oscillations

The LT8711's internal slope compensation circuit will prevent subharmonic oscillations that can occur when the duty cycle is greater than 50%, provided that the inductance exceeds a minimum value. In applications that operate with duty cycles greater than 50%, the inductance must be at least:

$$L_{MIN} \geq \frac{V_{IN} \cdot R_{SENSE} \cdot (2 \cdot DC - 1)}{40m \cdot DC \cdot f}, \text{ Buck Topology}$$

$$L_{MIN} \geq \frac{V_{IN} \cdot R_{SENSE} \cdot (2 \cdot DC - 1)}{40m \cdot DC \cdot f \cdot (1 - DC)}, \text{ Other Topologies}$$

APPENDIX

where

$L_{MIN} = L1$ for buck, boost and buck-boost topologies

$L_{MIN} = L1 = L2$ for coupled dual inductor topologies (SEPIC and ZETA)

$L_{MIN} = L1 \parallel L2$ for uncoupled dual inductor topologies (SEPIC and ZETA)

Inductor Current Rating

The inductor(s) must have a rating greater than its (their) peak operating current to prevent inductor saturation, which would result in efficiency losses.

POWER MOSFET SELECTION

The LT8711 requires two external power MOSFETs, an NFET switch for the BG gate driver and a PFET switch for the TG gate driver. It is important to select MOSFETs for optimizing efficiency. For choosing an NFET and PFET, the important device parameters are:

1. Breakdown voltage (BV_{DSS})
2. Gate threshold voltage (V_{GSTH})
3. On-resistance ($R_{DS(ON)}$)
4. Total gate charge (Q_G)
5. Turn-off delay time ($t_{D(OFF)}$)
6. Package has exposed paddle

If operating close to the BV_{DSS} rating of the MOSFET, check the leakage specifications on the MOSFET because leakage can decrease the efficiency of the converter.

The NFET and PFET gate-to-source drive is 5V typical. The BG gate driver can begin switching when the $INTV_{CC}$ voltage exceeds $\sim 4.1V$, so ensure the selected NFET is in the linear mode of operation with 4.1V of gate-to-source drive to prevent possible damage to the NFET.

The TG gate driver can begin switching when the $BIAS-INTV_{EE}$ voltage exceeds $\sim 3.85V$, so it is optimal that the PFET be in the linear mode of operation with 3.85V of gate-to-source drive. Try to choose a PFET with a low body diode reverse recovery time to minimize stored charge in the PFET. The stored charge in the PFET body diode gets

removed when the NFET switch turns on and can lead to efficiency hits especially in applications where the V_{DS} of the PFET (during off-time) is high. For these applications, it may be beneficial to put a Schottky diode across the PFET to reduce the amount of charge in the PFET body diode.

Power MOSFET on-resistance and total gate charge go hand-in-hand and are typically inversely proportional to each other; the lower the on-resistance, the higher the total gate charge. Choose MOSFETs with an on-resistance to give a voltage drop to be less than 300mV at the peak current. At the same time, choose MOSFETs with a lower total gate charge to reduce LT8711 power dissipation and MOSFET switching losses.

The turn-off delay time ($t_{D(OFF)}$) of available NFETs is generally smaller than the LT8711's non-overlap time. However, the turn-off time of the available PFETs should be looked at before deciding on a PFET for a given application. The turn-off time must be less than the non-overlap time of the LT8711 or else the NFET and PFET could be on at the same time and damage to external components may occur. If the PFET turn-off delay time as specified in the data sheet is less than the LT8711 non-overlap time, then the PFET is good to use. If the turn-off delay time is longer than the non-overlap time, it doesn't necessarily mean it can't be used. It may be unclear how the PFET manufacturer measures the turn-off delay time, so it is best to measure the PFET turn-off delay time with respect to the PFET gate voltage.

Finally, both the NFET and PFET power MOSFETs should be in a package with an exposed paddle for the drain connection to be able to dissipate heat. The on-resistance of MOSFETs is proportional to temperature, so it's more efficient if the MOSFETs are running cool with the help of the exposed paddle. See Table 8 for a list of power MOSFET manufacturers.

Table 8. Power MOSFET (NFET and PFET) Manufacturers

Fairchild Semiconductor	www.fairchildsemi.com
On-Semiconductor	www.onsemi.com
Vishay	www.vishay.com
Diodes Inc.	www.diodes.com

APPENDIX

INPUT AND OUTPUT CAPACITOR SELECTION

Input and output capacitance is necessary to suppress voltage ripple caused by discontinuous current moving in and out of the regulator. A parallel combination of capacitors is typically used to achieve high capacitance and low ESR (equivalent series resistance). Tantalum, special polymer, aluminum electrolytic and ceramic capacitors are all available in surface mount packages. Capacitors with low ESR and high ripple current ratings, such as OS-CON and POSCAP are also available.

Ceramic capacitors should be placed near the regulator input and output to suppress high frequency switching noise. A minimum 1 μ F ceramic capacitor should also be placed from V_{IN} to GND and from $EXTV_{CC}$ to GND as close to the LT8711 pins as possible. Due to their excellent low ESR characteristics, ceramic capacitors can significantly reduce ripple voltage and help reduce power loss in the higher ESR bulk capacitors. X5R or X7R dielectrics are preferred, as these materials retain their capacitance over wide voltage and temperature ranges. Many ceramic ca-

pacitors, particularly 0805 or 0603 case sizes, have greatly reduced capacitance at the desired operating voltage.

COMPENSATION – ADJUSTMENT

To compensate the feedback loop of the LT8711, a series resistor capacitor network in parallel with an optional single capacitor should be connected from the V_C pin to GND. For most applications, choose a series capacitor in the range of 0.47nF to 10nF with 2.2nF being a good starting value. The optional parallel capacitor should range in value from 47pF to 220pF with 100pF being a good starting value. The compensation resistor, R_C , is usually in the range of 10k to 100k. A good technique to compensate a new application is to use a 100k potentiometer in place of the series resistor R_C . With the series and parallel capacitors at 2.2nF and 100pF respectively, adjust the potentiometer while observing the transient response and the optimum value for R_C can be found. The series capacitor can be reduced or increased from 2.2nF to speed up the converter or slow down the converter, respectively.

TYPICAL APPLICATIONS

400kHz, 5V–40V Input to 3.3V/6.5A Buck

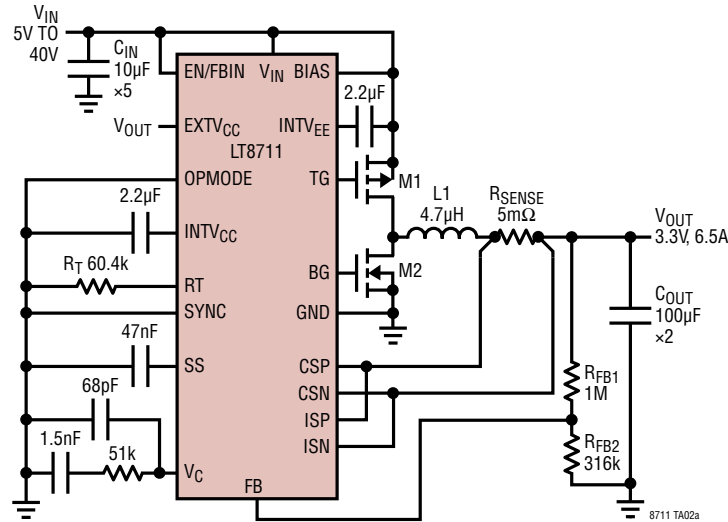

L1: COILCRAFT 4.7µH XAL7070-472
 M1: ST STL42P6LLF6
 M2: FAIRCHILD FDMC86520L

C_{IN}: 10µF, 50V, X7R
 ADDITIONAL 47µF, 50V ELECTROLYTIC CAP ON V_{IN}
 C_{OUT}: 100µF, 6.3V, X7R
 ADDITIONAL 470µF, 16V ELECTROLYTIC CAP ON V_{OUT}

Efficiency vs Load Current

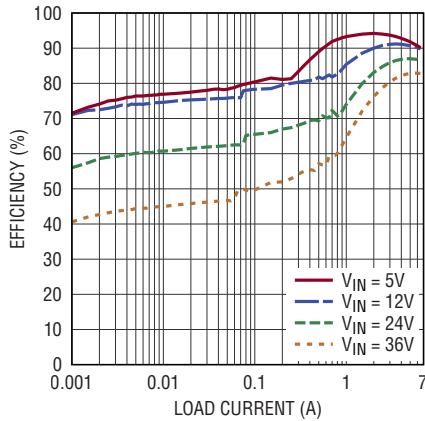

Transient Response with 2A to 5.5A to 2A Output Load Step

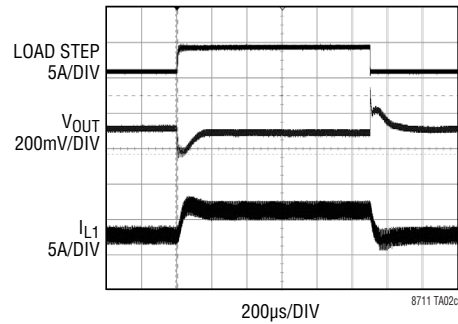

TYPICAL APPLICATIONS

400kHz, 12V Input to 24V/3A Boost Converter

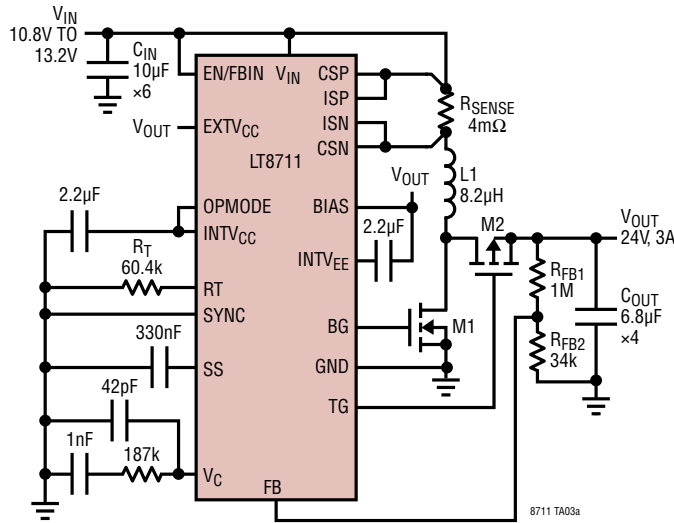

L1: WÜRTH 8.2µH WE-HCI 7443550820
 M1: INFINEON BSC026N04
 M2: ST STL60P4LLF6

C_{IN}: 10µF, 50V, X7R
 ADDITIONAL 47µF, 50V ELECTROLYTIC CAP ON V_{IN}
 C_{OUT}: 6.8µF, 50V, X7R
 ADDITIONAL 270µF, 50V ELECTROLYTIC CAP ON V_{OUT}

Efficiency vs Load Current

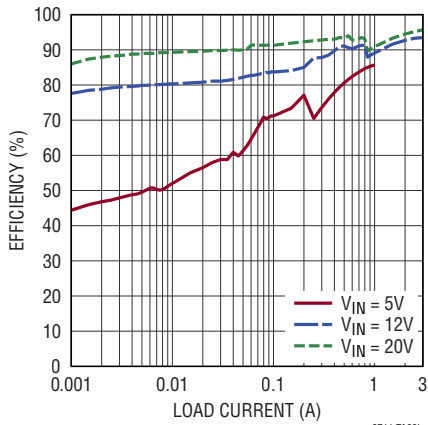

Transient Response with 1A to 2.5A to 1A Output Load Step (V_{IN} = 12V)

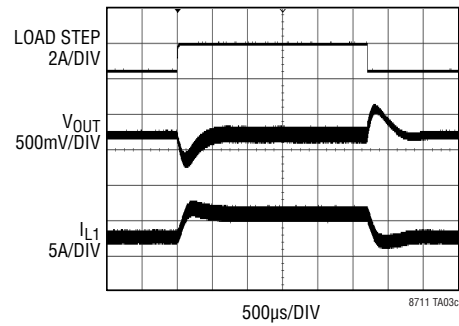

TYPICAL APPLICATIONS

200kHz, 4.5V–40V Input to 12V/4A SEPIC

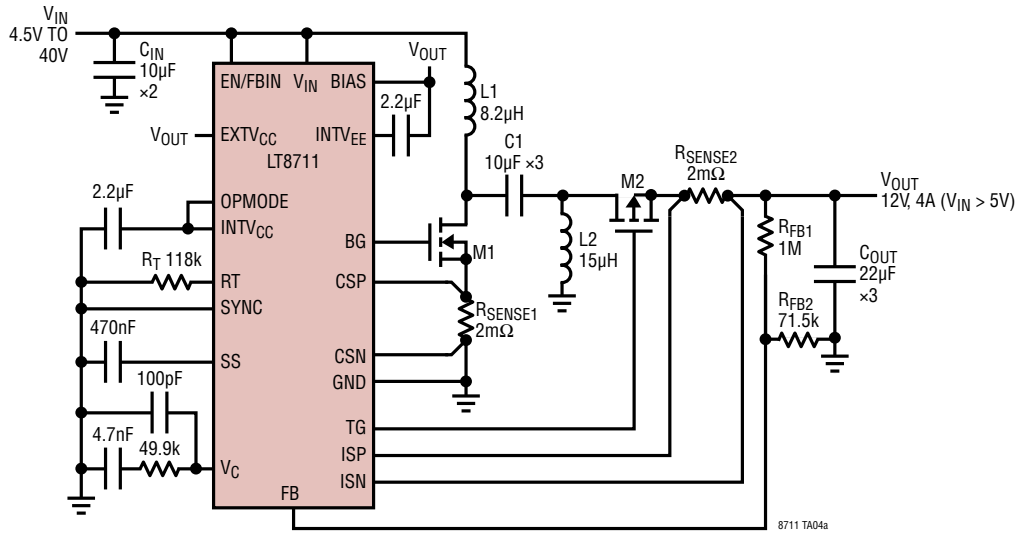

L1: COILCRAFT 8.2µH XAL1510-822ME
 L2: COILCRAFT 15µH XAL1510-153ME
 M1: VISHAY SiR826ADP
 M2: ST STL42P6LLF6

C_{IN}: 10µF, 50V, X7R
 ADDITIONAL 56µF, 50V ELECTROLYTIC CAP ON V_{IN}
 C_{OUT}: 22µF, 25V, X7R
 ADDITIONAL 270µF, 25V ELECTROLYTIC CAP ON V_{OUT}

Efficiency vs Load Current

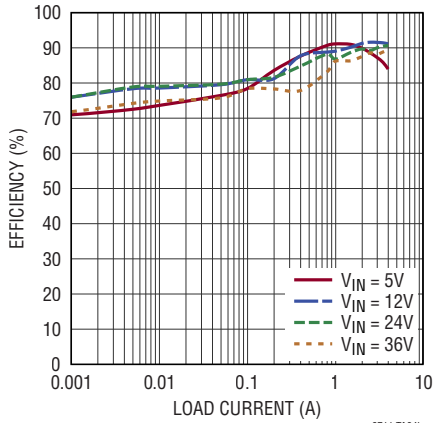

Transient Response with 2A to 4A to 2A Output Load Step (V_{IN} = 12V)

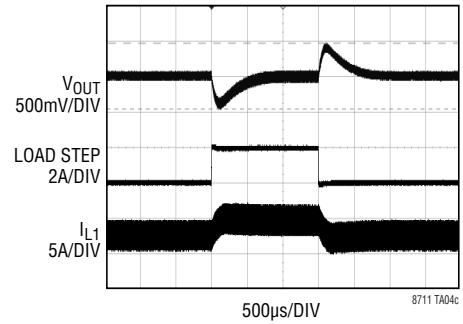

TYPICAL APPLICATIONS

200kHz, 5V–40V Input to 12V/3.5A ZETA Converter

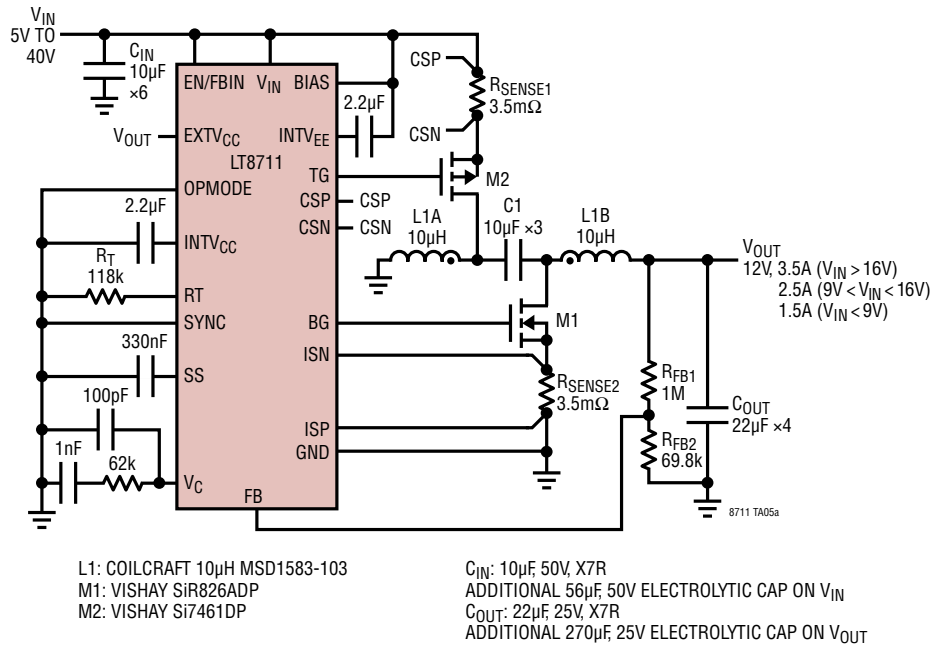

Efficiency vs Load Current

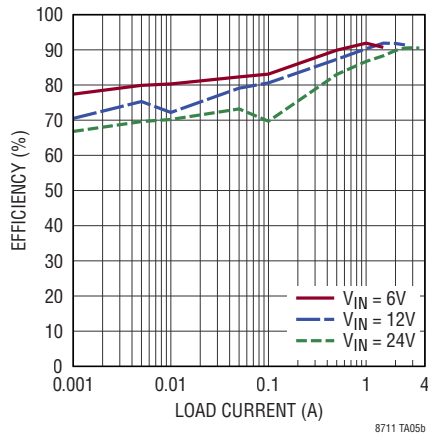

Transient Response with 1.5A to 3A to 1.5A Output Load Step (VIN = 16V)

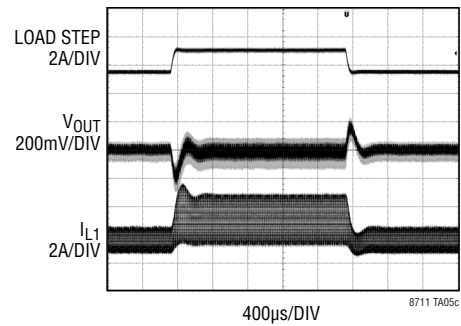

TYPICAL APPLICATIONS

400kHz, 5V–40V Input to 12V/3.5A Buck-Boost Converter

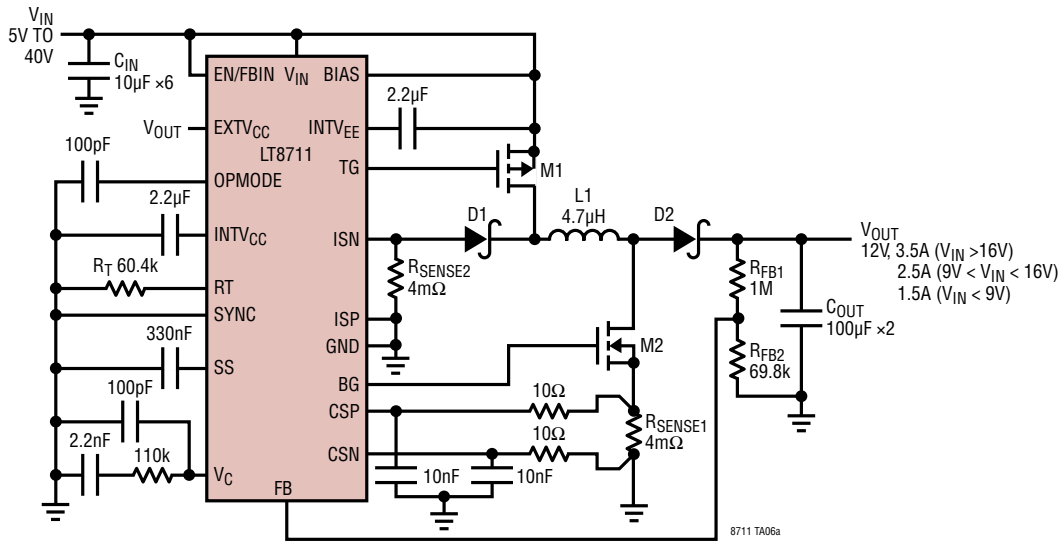

L1: COILCRAFT 4.7µH XAL8080-472ME
 M1: ST STL60P4LLF6
 M2: FAIRCHILD FDMC86520L
 D1, D2: VISHAY SS10P6M3

CIN: 10µF, 50V, X7R
 ADDITIONAL 47µF, 50V ELECTROLYTIC CAP ON VIN
 COUT: 100µF, 16V, X7R
 ADDITIONAL 390µF, 16V ELECTROLYTIC CAP ON VOUT

Efficiency vs Load Current

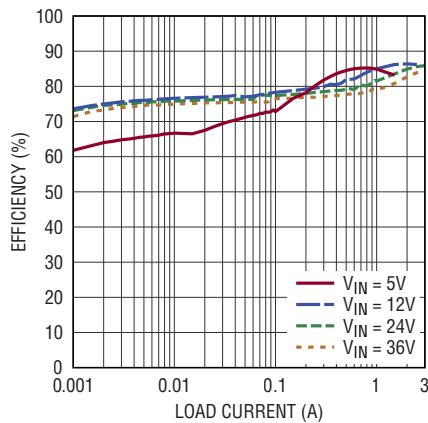

Transient Response with 1.5A to 3A to 1.5A Output Load Step (VIN = 9V)

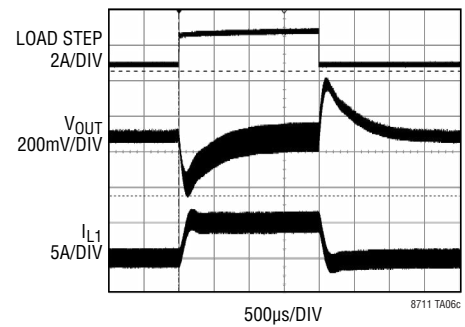

PACKAGE DESCRIPTION

Please refer to <http://www.linear.com/product/LT8711#packaging> for the most recent package drawings.

FE Package 20-Lead Plastic TSSOP (4.4mm) (Reference LTC DWG # 05-08-1663 Rev K) Exposed Pad Variation CB

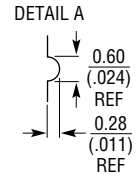
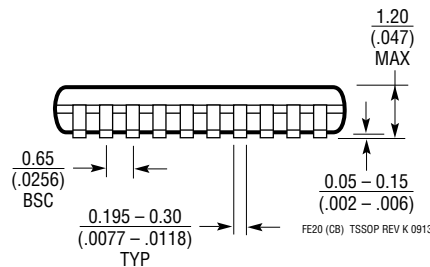
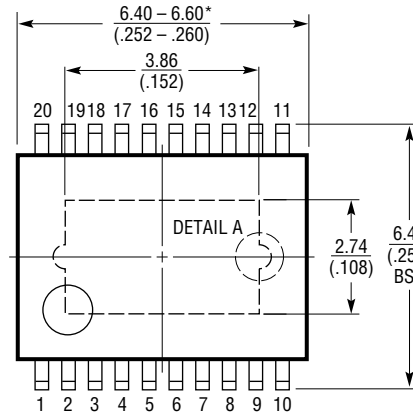
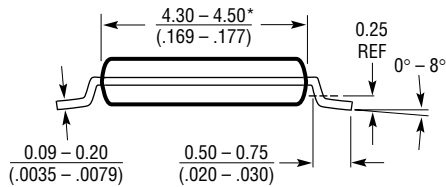
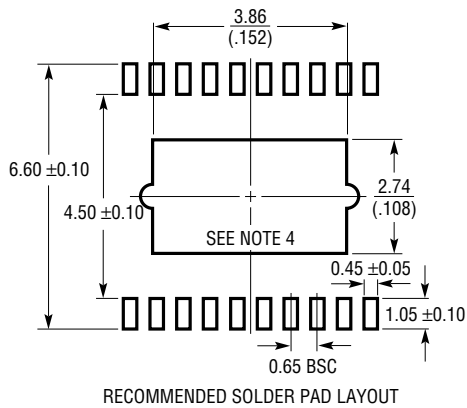

DETAIL A IS THE PART OF THE LEAD FRAME FEATURE FOR REFERENCE ONLY NO MEASUREMENT PURPOSE

NOTE:

1. CONTROLLING DIMENSION: MILLIMETERS
 2. DIMENSIONS ARE IN $\frac{\text{MILLIMETERS}}{\text{(INCHES)}}$
 3. DRAWING NOT TO SCALE
 4. RECOMMENDED MINIMUM PCB METAL SIZE FOR EXPOSED PAD ATTACHMENT
- *DIMENSIONS DO NOT INCLUDE MOLD FLASH. MOLD FLASH SHALL NOT EXCEED 0.150mm (.006") PER SIDE

PACKAGE DESCRIPTION

Please refer to <http://www.linear.com/product/LT8711#packaging> for the most recent package drawings.

UDC Package 20-Lead Plastic QFN (3mm × 4mm) (Reference LTC DWG # 05-08-1742 Rev 0)

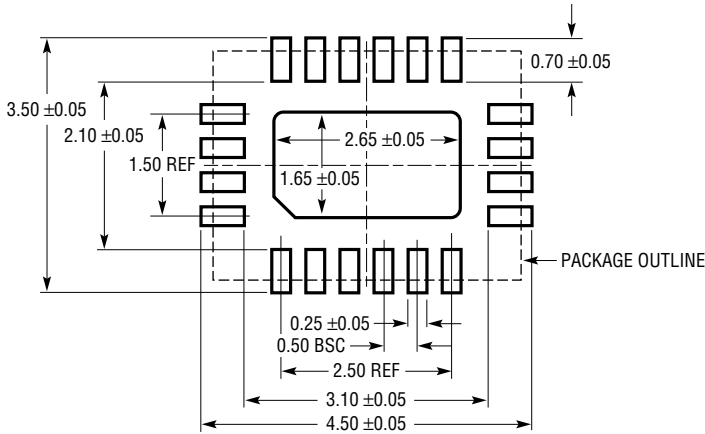

RECOMMENDED SOLDER PAD PITCH AND DIMENSIONS
APPLY SOLDER MASK TO AREAS THAT ARE NOT SOLDERED

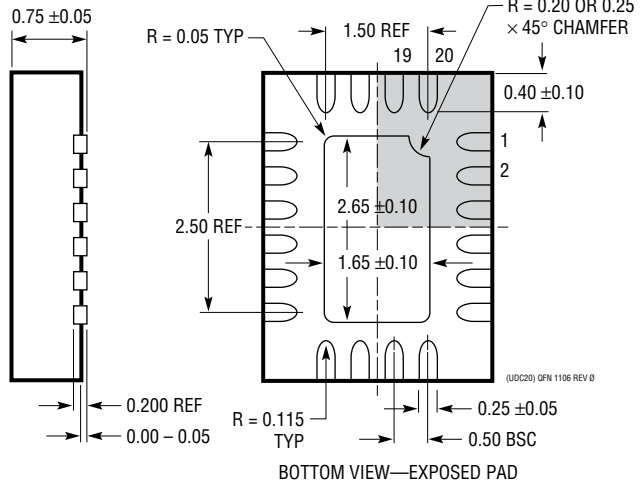
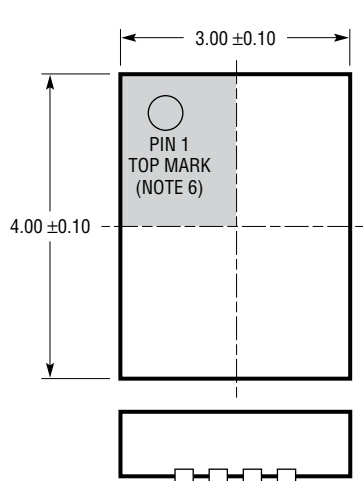

BOTTOM VIEW—EXPOSED PAD

NOTE:

1. DRAWING IS NOT A JEDEC PACKAGE OUTLINE
2. DRAWING NOT TO SCALE
3. ALL DIMENSIONS ARE IN MILLIMETERS
4. DIMENSIONS OF EXPOSED PAD ON BOTTOM OF PACKAGE DO NOT INCLUDE MOLD FLASH. MOLD FLASH, IF PRESENT, SHALL NOT EXCEED 0.15mm ON ANY SIDE
5. EXPOSED PAD SHALL BE SOLDER PLATED
6. SHADED AREA IS ONLY A REFERENCE FOR PIN 1 LOCATION ON THE TOP AND BOTTOM OF PACKAGE

(UDC20) QFN 1106 REV 0

REVISION HISTORY

REV	DATE	DESCRIPTION	PAGE NUMBER
A	04/18	Changed from 25mV to 27mV in last sentence.	13

TYPICAL APPLICATION

Boost Pre-Regulator for Automotive Stop-Start/Idle

L1: WÜRTH 5.6μH WE-HCI 7443557560
 M1: FAIRCHILD FDS8447
 M2: FAIRCHILD FDD4141
 D1: FAIRCHILD MBR3340
 C_{IN}: 10μF, 50V, X7R
 ADDITIONAL 56μF, 50V ELECTROLYTIC CAP ON V_{IN}
 C_{OUT}: 22μF, 25V, X7R
 ADDITIONAL 270μF, 25V ELECTROLYTIC CAP ON V_{OUT}

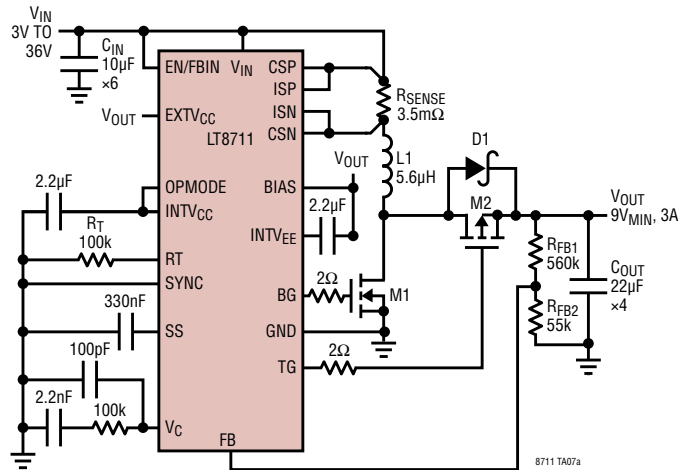

No-Load Supply Current

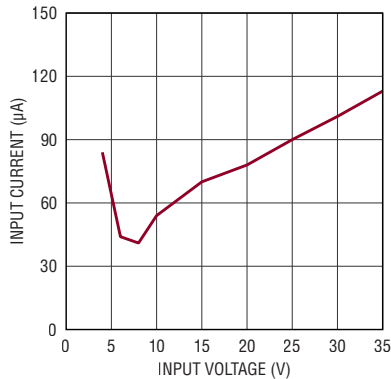

Transient V_{IN} and V_{OUT} Waveforms

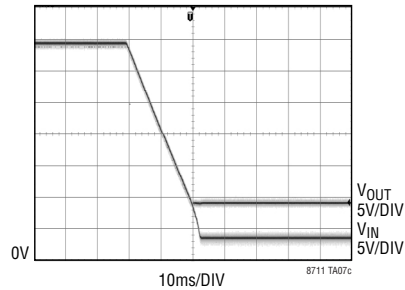

RELATED PARTS

PART NUMBER	DESCRIPTION	COMMENTS
LT3757A	Boost, Flyback, SEPIC and Inverting Controller	2.9V ≤ V _{IN} ≤ 40V, 100kHz to 1MHz Programmable Operating Frequency, 3mm × 3mm DFN-10 and MSOP-10E
LT3758A	Boost, Flyback, SEPIC and Inverting Controller	5.5V ≤ V _{IN} ≤ 100V, 100kHz to 1MHz Programmable Operating Frequency, 3mm × 3mm DFN-10 and MSOP-10E
LT3957A	Boost, Flyback, SEPIC and Inverting Converter with 5A, 40V Switch	3V ≤ V _{IN} ≤ 40V, 100kHz to 1MHz Programmable Operating Frequency, 5mm × 6mm QFN
LT3958	Boost, Flyback, SEPIC and Inverting Converter with 3.3A, 84V Switch	5V ≤ V _{IN} ≤ 80V, 100kHz to 1MHz Programmable Operating Frequency, 5mm × 6mm QFN
LT8705A	80V V _{IN} and V _{OUT} Synchronous 4-Switch Buck-Boost DC/DC Controller	2.8V ≤ V _{IN} ≤ 80V, 100kHz to 400kHz Programmable Operating Frequency, 5mm × 7mm QFN-38 and TSSOP-38
LT8709	Negative Input Synchronous Multitopology DC/DC Control	-80V ≤ V _{IN} ≤ -4.5V, Up to 400kHz Programmable Operating Frequency, TSSOP-20
LT8710	Synchronous SEPIC/Inverting/Boost Controller with Output Current Control	4.5V ≤ V _{IN} ≤ 80V, 100kHz to 1MHz Programmable Operating Frequency, TSSOP-20
LT8714	Bipolar Output Synchronous Controller with Seamless Four Quadrant Operation	4.5V ≤ V _{IN} ≤ 80V, Output Can Source or Sink Current for Any Output Voltage, Switching Frequency Up to 750kHz, 20-Lead TSSOP

Mouser Electronics

Authorized Distributor

Click to View Pricing, Inventory, Delivery & Lifecycle Information:

[Analog Devices Inc.:](#)

[LT8711IFE#PBF](#) [LT8711IUDC#PBF](#) [LT8711IFE#TRPBF](#) [LT8711EUDC#PBF](#) [LT8711EFE#TRPBF](#)
[LT8711EFE#PBF](#) [LT8711IUDC#TRPBF](#) [LT8711EUDC#TRPBF](#) [DC2234A](#)