

Bluetooth® Low Energy wireless network coprocessor



WLCSP34



QFN32

Features

- Low-power radio performance
 - Sleep current consumption down to 900 nA
 - TX current consumption 6.8 mA (@ -2 dBm, 3.0 V)
 - RX current consumption 6.2 mA (@ sensitivity level, 3.0 V)
 - Up to +8 dBm programmable output power level (@ antenna connector)
 - Excellent RF link budget (up to 96 dB)
 - Integrated DC-DC step-down converter and LDO regulators
- Bluetooth® 5.0 certified
 - Multi-master to multi-slave communication guaranteed
 - 2 masters to 6 slaves simultaneously
 - Up to 8 simultaneous connections handled
 - LE data length extension (up to 700 kbps at application level)
 - Over-the-air firmware update is 2.5 times faster
 - LE Privacy 1.2
 - Reduces the ability to be tracked over a period of time by changing the address on a frequent basis without involving the HOST and saving battery life
 - LE secure connections
 - The pairing mechanism is established with the elliptic curve Diffie-Hellman (ECDH) key agreement protocol enabling a secure key exchange mechanism preventing eavesdropping

Product status link

[BlueNRG-2N](#)

Product summary

Product summary	
Order codes	BlueNRG-232N
	BlueNRG-234N

Applications

- Watches
- Fitness, wellness and sports
- Consumer medical
- Security/proximity
- Remote control
- Home and industrial automation
- Assisted living
- Mobile phone peripherals
- Lighting
- PC peripherals

Description

The BlueNRG-2N is an ultra low power (ULP) network coprocessor solution for Bluetooth® low energy applications.

It embeds the STMicroelectronics's state-of-the-art RF radio IPs combining unparalleled performance with extremely long battery lifetime.

It is fully compliant with Bluetooth core specification version 5.0 and supports enhanced features such as state-of-the-art security, privacy, and extended packet length for faster data transfer up to 700 kbps at application level.

The BlueNRG-2N is Bluetooth® 5.0 certified ensuring interoperability with the latest generation of smartphones and other host devices.

The Bluetooth low energy stack runs on the embedded ARM Cortex-M0 core. The STMicroelectronics BLE stack is stored into the on-chip non-volatile Flash memory and it can be easily upgraded via SPI/UART as well through the dedicated STMicroelectronics software tools.

1 High performance and benefits

The BlueNRG-2N shows a reliable communication thanks to the best-in-class output power level assuring a robust communication even in a noisy corrupted scenario without compromising the overall power consumption. The BlueNRG-2N collaterals include comprehensive tools for developers such as a full featured SDK including:

- Templates
- High-level abstraction layer APIs (no BLE expertise required)
- Real-time debug capabilities

A dedicated firmware is provided to support the interface with an external application processor. The whole Bluetooth low energy stack runs in the BlueNRG-2N; the GATT profiles are provided to run in the application processor together with the application code. The figure below shows the network processor RF software layers.

Figure 1. BlueNRG-2N network processor RF software layers

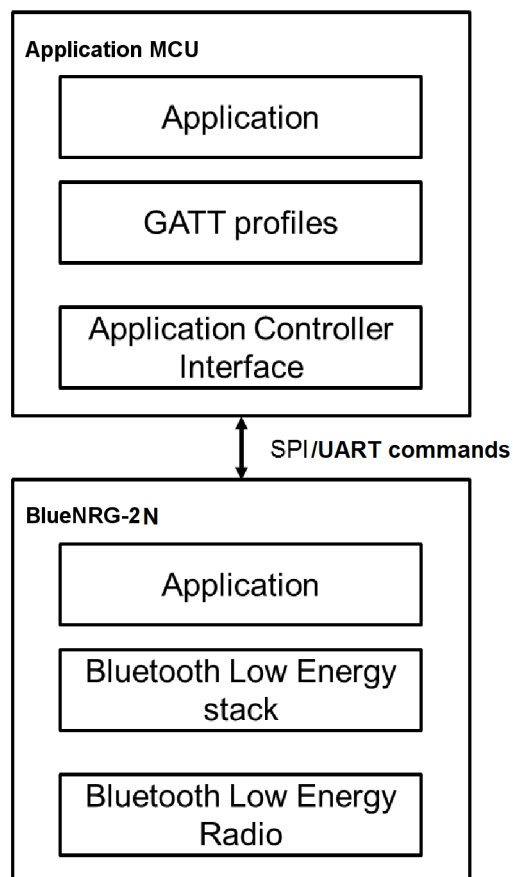

2 Functional details

The BlueNRG-2N integrates:

- ARM Cortex-M0 core
- Power management
- Clocks
- Bluetooth low energy radio
- Random number generator (RNG) (reserved for Bluetooth low energy protocol stack, but user applications can read it)
- External microcontroller interface (SPI/UART)
- Public key cryptography (PKA) (reserved for Bluetooth low energy protocol stack)

2.1 Core

The ARM® Cortex®-M0 processor has been developed to provide a low-cost platform that meets the needs of MCU implementation, with a reduced pin count and low-power consumption, while delivering outstanding computational performance and an advanced system response to interrupts.

The ARM® Cortex®-M0 32-bit RISC processor features exceptional code-efficiency, delivering the high-performance expected from an ARM core in the memory size usually associated with 8-bit and 16-bit devices.

The BlueNRG-2N has an embedded ARM core and is therefore compatible with all ARM tools and software. The ARM Cortex M0 processor is reserved for internal operations and it is not open to customer application developments.

2.2 Power management

The BlueNRG-2N integrates both a low dropout voltage regulator (LDO) and a step-down DC-DC converter to supply the internal BlueNRG-2N circuitry.

The BlueNRG-2N most efficient power management configuration is with DC-DC converter active where best power consumption is obtained without compromising performances. Nevertheless, a configuration based on LDO can also be used, if needed.

A simplified version of the state machine is shown below.

Figure 2. BlueNRG-2N power management state machine

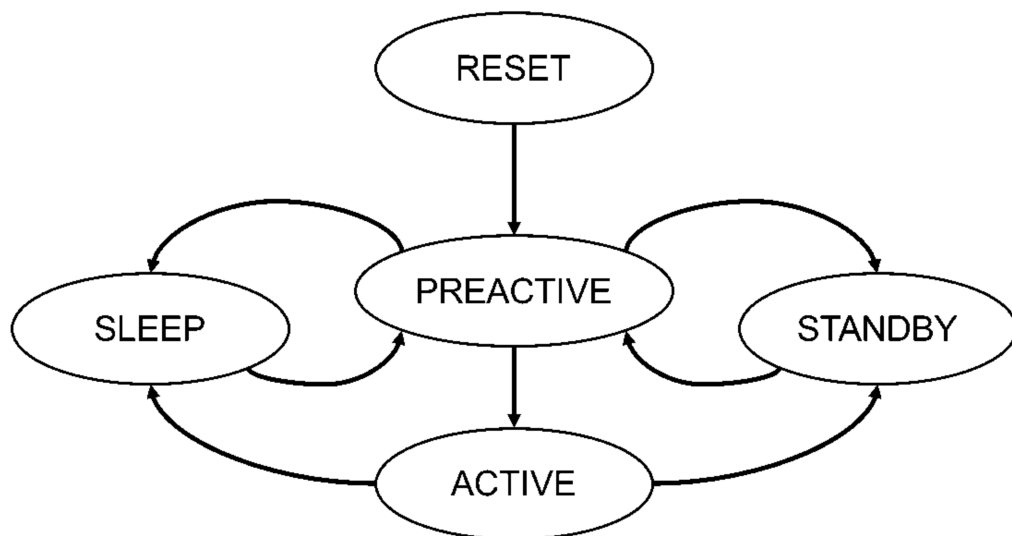

2.2.1 State description

2.2.1.1 **Preactive state**

The preactive state is the default state after a POR event.

In this state:

- All the digital power supplies are stable.
- The high frequency clock runs on internal fast clock RC oscillator (16 MHz).
- The low frequency clock runs on internal RC oscillator (32.768 kHz).

2.2.1.2 **Active state**

In this state:

- The high frequency runs on the accurate clock (16 MHz \pm 50 ppm) provided by the external XO. The internal fast clock RO oscillator is switched off.

2.2.1.3 **Standby state**

In this state:

- Only the digital power supplies necessary to keep the RAM in retention are used.

2.2.1.4 **Sleep state**

In this state:

- Only the digital power supplies necessary to keep the RAM in retention are used
- The low frequency oscillator is switched on

The wake-up from this low power state is driven by the following sources:

- Internal timers
- SPI CS (SPI mode only)

2.2.1.5 **Power saving strategy**

The application power saving strategy is based on clock stopping, dynamic clock gating, digital power supply switch-off and analog current consumption minimization.

A summary of functional blocks versus the BlueNRG-2N states is provided below.

Table 1. Relationship between the BlueNRG-2N states and functional blocks

Functional blocks	RESET	STANDBY	SLEEP	Preactive	Active	LOCK RX/ LOCK TX	RX	TX
LDO_SOFT_1V2 or LDO_SOFT_0V9	OFF	ON	ON	ON	ON	ON	ON	ON
LDO_STRONG_1V2	OFF	OFF	OFF	ON	ON	ON	ON	ON
LDO_DIG_1V8	OFF	OFF	OFF	ON	ON	ON	ON	ON
SMPS	OFF	OFF	OFF	ON	ON	ON	ON	ON
LDO_DIG_1V2	OFF	OFF	OFF	ON	ON	ON	ON	ON
BOR	OFF	OFF	OFF	ON	ON	ON	ON	ON
16 MHz RO	OFF	OFF	OFF	ON	OFF	OFF	OFF	OFF
16 MHz XO	OFF	OFF	OFF	OFF	ON	ON	ON	ON
32 kHz RO or XO	OFF	OFF	ON	ON	ON	ON	ON	ON

2.3 Clocks and reset management

The BlueNRG-2N embeds an RC low-speed frequency oscillator at 32 kHz and an RO high-speed frequency oscillator at 16 MHz.

The low-frequency clock is used in low power mode and can be supplied either by a 32.7 kHz oscillator that uses an external crystal and guarantees up to \pm 50 ppm frequency tolerance, or by a ring oscillator, which does not require any external components.

The primary high-speed frequency clock is a 32 MHz crystal oscillator. A fast-starting 16 MHz ring oscillator provides the clock while the crystal oscillator is starting up. Frequency tolerance of the high-speed crystal oscillator is ± 50 ppm.

Usage of the high-speed crystal usage is strictly necessary for RF communications.

2.3.1 Reset management

Figure 3. Reset and wake-up generation shows the general principle of reset. Releasing the reset pin takes the chip out of shutdown state. The wake-up logic is powered and receives the POR. Each time the wake-up controller decides to exit sleep or standby modes, it generates a reset for the core logic. The core logic can also be reset by:

- Watchdog
- Reset request from the processor (system reset)
- LOCKUP state of the Cortex-M0

The SWD logic is reset by the POR. It is important to highlight that the reset pin actually powers down the chip, so it is not possible to perform debug access with system under reset.

Figure 3. Reset and wake-up generation

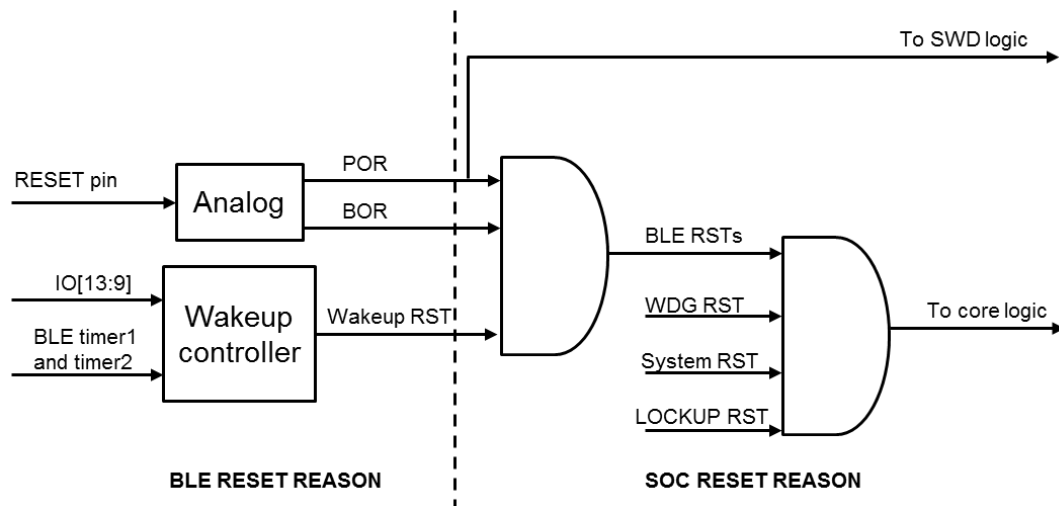

If, for any reason, the user would like to power off the device there are two options:

1. Force RESETN pin to ground, keeping VBAT level
2. To put VBAT pins to ground (e.g. via a transistor)

In the second option, care must be taken to ensure that no voltage is applied to any of the other pins as the device can be powered and have an anomalous power consumption. The ST recommendation is to use RESETN whenever it is possible.

2.3.1.1 Power-on-Reset

The Power-on-Reset (POR) signal is the combination of the POR signal and the BOR signal generated by the analog circuitry contained in the BlueNRG-2N device. The combination of these signals is used to generate the input to the Cortex-M0, which is used to reset the debug access port (DAP) of the processor. It is also used to generate the signal, which resets the debug logic of the Cortex-M0. The POR signal also resets the TAP controller of the BlueNRG-2N and a part of the Flash controller (managing the Flash memory boot, which does not need to be impacted by system resets).

The BOR reset is enabled by default. At software level, it can be decided to change the default values after reset.

2.3.1.2 Power-up sequence

The starting sequence of the BlueNRG-2N supply and reset signal is shown below.

Figure 4. BlueNRG-2N power-up sequence

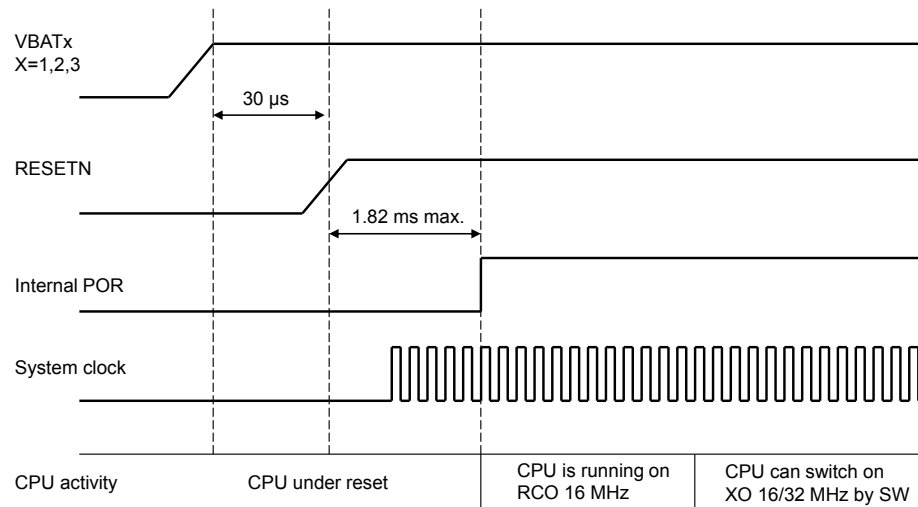

- The VBATx power must only be raised when RESETN pin is low.
- The different VBATx (x=1,2,3) power can be raised separately or together.
- Once the VBATx (x=1,2,3) reaches the nominal value, the RESETN pin could be driven high after a 30 µs.
- The internal POR is released once internal LDOs are established and RCO clock is ready.
- The system starts on RCO 16 MHz clock system. The software is responsible for configuring the XO 16/32 MHz when necessary.

Note: The minimum negative pulse to reset the system must be at least 30 µs.

The POR circuit is powered by a 1.2 V regulator, which must also be powered up with the correct startup sequence. Before VBAT has reached the nominal value, RESETN line must be kept low. An external RC circuit on RESETN pin adds a delay that can prevent RESETN signal from going high before VBAT has reached the nominal value.

Figure 5. Reset circuit

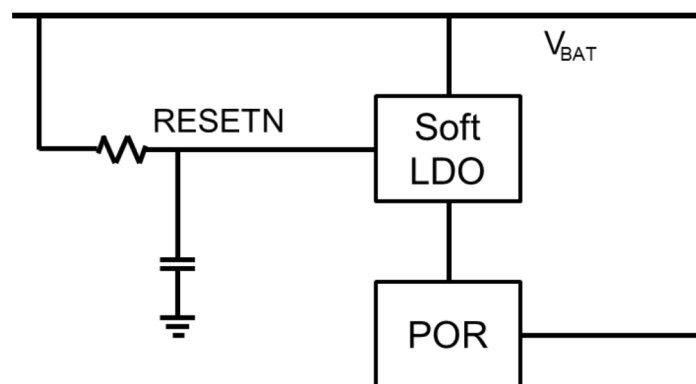

If the above conditions are not satisfied, ST cannot guarantee the correct operation of the device.

The BlueNRG-2N could inform the external microcontroller via the host interface protocol on the internal reset reason, which includes: POR, BOR, watchdog, lockup.

2.4 TX/RX event alert

The BlueNRG-2N is provided with the ANATEST1 (pin 14 for QFN32 package, pin D4 for WCSP34 package) signal which alerts forthcoming transmission or reception event. The ANATEST1 pin switches to high level about 18 μ s before transmission before reception. Then, it switches to low level at the end of the event. The signal can be used for controlling external antenna switching and supporting coexistence with other wireless technologies.

2.5 SWD debug feature

The BlueNRG-2N embeds the ARM serial wire debug (SWD) port. It is two pins (clock and single bi-directional data) debug interface, providing all the debug functionality plus real-time access to system memory without halting the processor or requiring any target resident code.

The SWD interface is provided to allow firmware upgrade on the device in the production lines.

Table 2. SWD port

Pin functionality	Pin name	Pin description
SWCLK	IO9	SWD clock signal
SWDIO	IO10	SWD data signal

The Cortex-M0 subsystem of the BlueNRG-2N embeds four breakpoints and two watchpoints.

2.6 Bluetooth low energy radio

The BlueNRG-2N integrates an RF transceiver compliant to the Bluetooth specification and to the standard national regulations in the unlicensed 2.4 GHz ISM band.

The RF transceiver requires very few external discrete components. It provides 96 dB link budgets with excellent link reliability, keeping the maximum peak current below 15 mA.

In transmit mode, the power amplifier (PA) drives the signal generated by the frequency synthesizer out to the antenna terminal through a very simple external network. The power delivered as well as the harmonic content depends on the external impedance seen by the PA.

2.6.1 Radio operating modes

Several operating modes are defined for the BlueNRG-2N radio:

- Reset mode
- Sleep mode
- Active mode
- Radio mode
 - RX mode
 - TX mode

In Reset mode, the BlueNRG-2N is in ultra-low power consumption: all voltage regulators, clocks and the RF interface are not powered. The BlueNRG-2N enters Reset mode by asserting the external Reset signal. As soon as it is de-asserted, the device follows the normal activation sequence to transit to active mode.

In sleep mode either the low speed crystal oscillator or the low speed ring oscillator are running, whereas the high speed oscillators are powered down as well as the RF interface. The state of the BlueNRG-2N is retained and the content of the RAM is preserved.

While in sleep mode, the BlueNRG-2N waits until an internal timer expires and then it goes into active mode.

In active mode the BlueNRG-2N is fully operational: all interfaces, including RF, are active as well as all internal power supplies together with the high speed frequency oscillator. The MCU core is also running.

Radio mode differs from active mode as the RF transceiver is also active and is capable of either transmitting or receiving.

2.7 Pre-programmed bootloader

The BlueNRG-2N device has a pre-programmed bootloader supporting UART protocol with automatic baud rate detection. The main features of the embedded bootloader are:

- Auto baud rate detection up to 460 kbps
- Flash mass erase, section erase
- Flash programming
- Flash readout protection enable/disable

The pre-programmed bootloader is an application which is stored on the BlueNRG-2N internal ROM at manufacturing time by STMicroelectronics. This application allows upgrading the device Flash with a user application using a serial communication channel (UART).

Bootloader is activated by hardware by forcing IO7 high during power-up or hardware Reset, otherwise, the application residing in Flash is launched.

Note: The customer application must ensure that IO7 is forced low during power-up. Bootloader protocol is described in a separate application note.

2.8 Firmware image

The Bluetooth Low Energy stack runs on the embedded ARM Cortex-M0 core. The stack is stored on the on-chip non-volatile Flash memory and can be easily upgraded via SPI.

The device comes pre-programmed with a production-ready stack image (version may change at any time without notice). A different or more up-to-date stack image can be downloaded from the ST website and programmed on the device through the ST provided software tools.

2.9 Unique device serial number

The BlueNRG-2N device has a unique six-byte serial number stored at address 0x100007F4: it is stored as two words (8 bytes) at addresses 0x100007F4 and 0x100007F8 with unique serial number padded with 0xAA55. Specific API allows such locations to get access.

3 Pin description

The BlueNRG-2N comes in two package versions: WCSP34 offering 14 GPIOs, QFN32 offering 15 GPIOs. Figure 6. BlueNRG-2N pinout top view (QFN32) shows the QFN32 pinout, and Figure 7. BlueNRG-2N ball out top view (WCSP34) shows the WCSP34 ball out.

Figure 6. BlueNRG-2N pinout top view (QFN32)

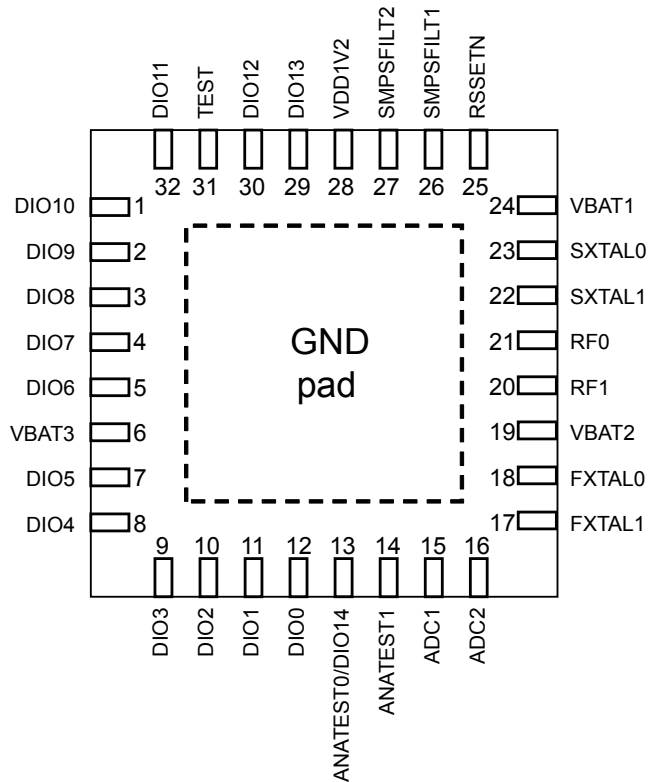

Figure 7. BlueNRG-2N ball out top view (WCSP34)

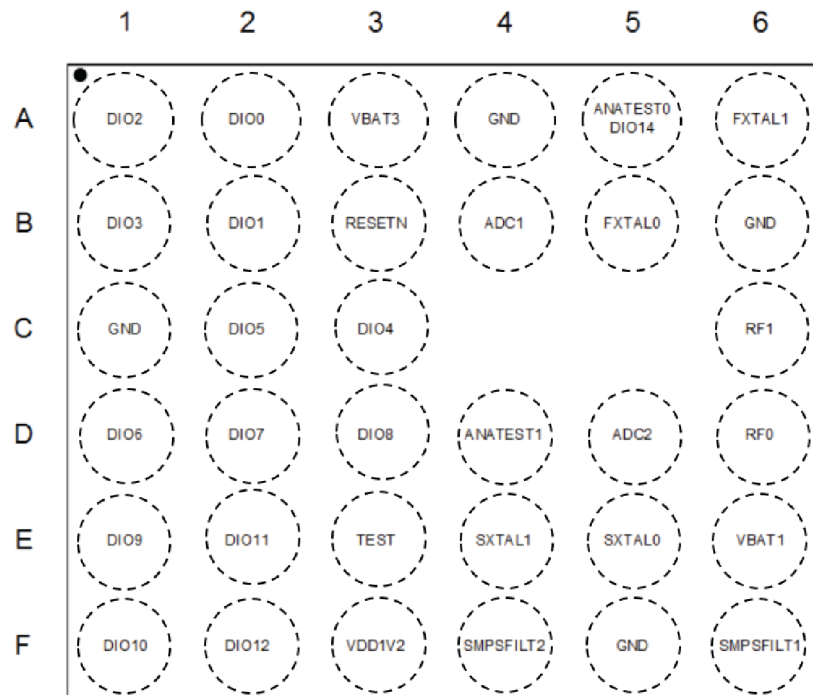
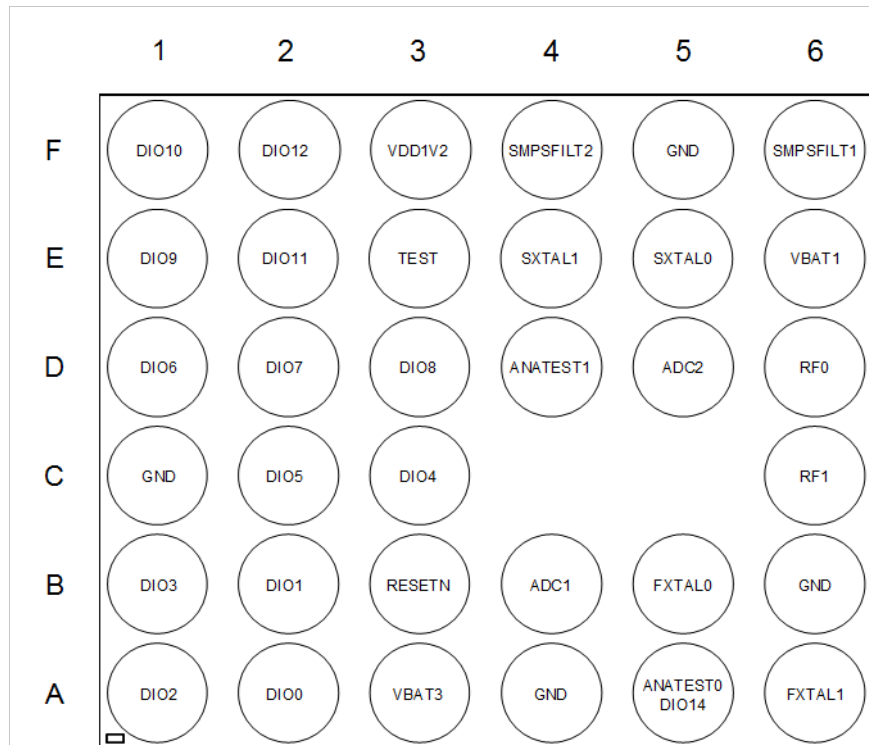

Figure 8. BlueNRG-2N ball out bottom view (WCSP34)

Table 3. Pinout description

Pins		Name	I/O	Description
QFN32	WCSP34			
1	F1	DIO10	I/O	SWDIO, not connected
2	E1	DIO9	I/O	SWCLK, not connected
3	D3	DIO8	I/O	UART_TXD
4	D2	DIO7/BOOT ⁽¹⁾	I/O	Bootloader pin SPI_IRQ
5	D1	DIO6	I/O	Reserved, put to ground
6	A3	VBAT3	VDD	Battery voltage input
-	-			
7	C2	DIO5	I/O	Reserved, put to ground
8	C3	DIO4	I/O	Reserved, put to ground
9	B1	DIO3 ⁽²⁾	I/O	SPI_IN
10	A1	DIO2	I/O	SPI_OUT
11	B2	DIO1	I/O	Reserved, put to ground
12	A2	DIO0	I/O	SPI_CLK
13	A5	DIO14	I/O	Reserved, not connected
		ANATEST0	O	Analog output

Pins		Name	I/O	Description
QFN32	WCSP34			
14	D4	ANATEST1	O	Analog output, not connected
15	B4	ADC1	I	Connect to ground
16	D5	ADC2	I	Connect to ground
17	A6	FXTAL1	I	32 MHz crystal
18	B5	FXTAL0	I	32 MHz crystal
19	-	VBAT2	VDD	Battery voltage input
20	C6	RF1	I/O	Antenna + matching circuit connection
21	D6	RF0	I/O	Antenna + matching circuit connection
22	E4	SXTAL1	I	32 kHz crystal
23	E5	SXTAL0	I	32 kHz crystal
24	E6	VBAT1	VDD	Battery voltage input
25	B3	RESETN	I	System reset
26	F6	SMPSFILT1	I	SMPS output to external filter
27	F4	SMPSFILT2	I/O	SMPS output to external filter/battery voltage input
28	F3	VDD1V2	O	1.2V digital core output
29	-	DIO13	I/O	Reserved, put to ground by a pull-down resistor
30	F2	DIO12	I/O	Connect to VDD for UART interface by a pull-up resistor Connect to ground for SPI interface by a pull-down resistor
31	E3	TEST	I	Test pin put to GND
32	E2	DIO11	I/O	UART_RXD/SPI_CS
-	A4	GND	GND	Ground
-	B6			
-	C1			
-	F5			

1. The pin IO7/BOOT is monitored by bootloader after power-up or hardware reset and it should be low to prevent unwanted bootloader activation.
2. The pin IO3 is monitored by start-up FW after power-up or hardware reset and it should be low to prevent unwanted start-up FW activation.

4 Application circuit

The schematics below are purely indicative.

Figure 9. Application circuit: active DC-DC converter QFN32 package

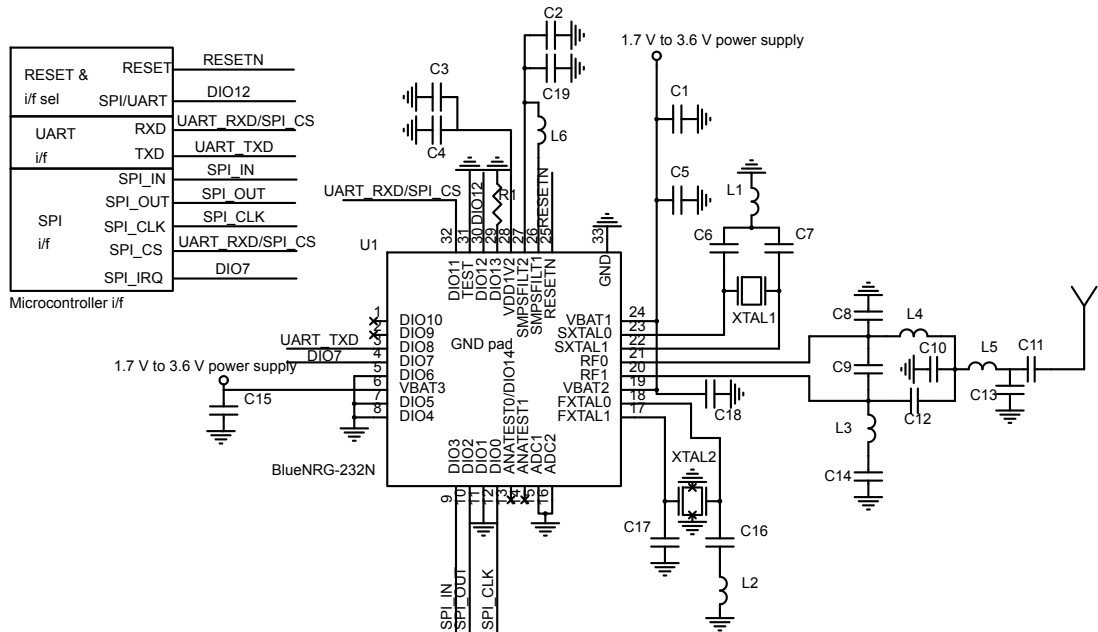

Figure 10. Application circuit: non-active DC-DC converter QFN32 package

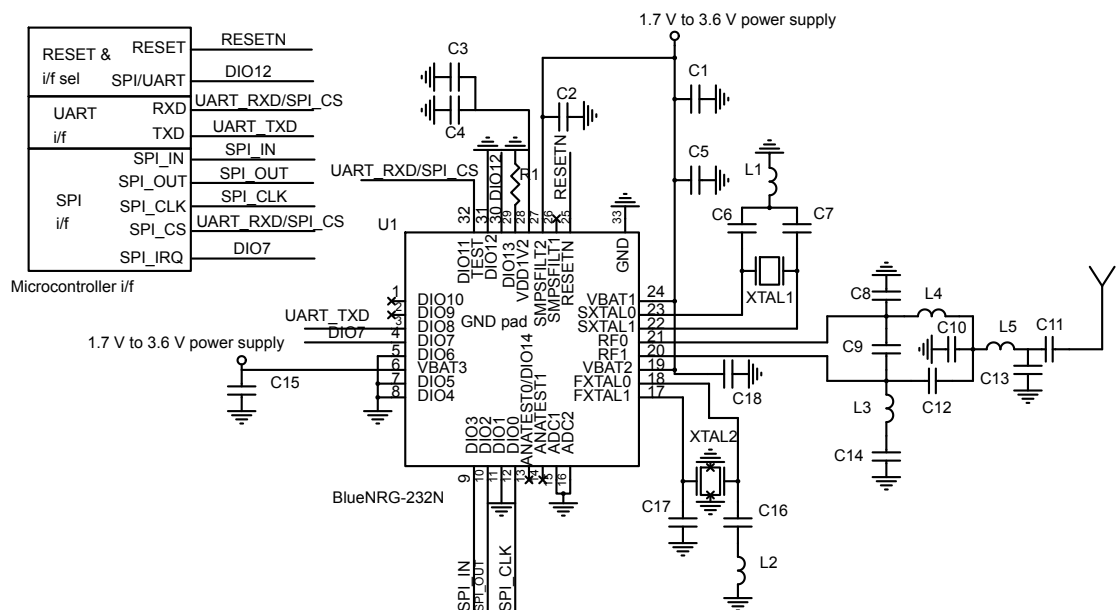

Figure 11. Application circuit: active DC-DC converter WCSP34 package

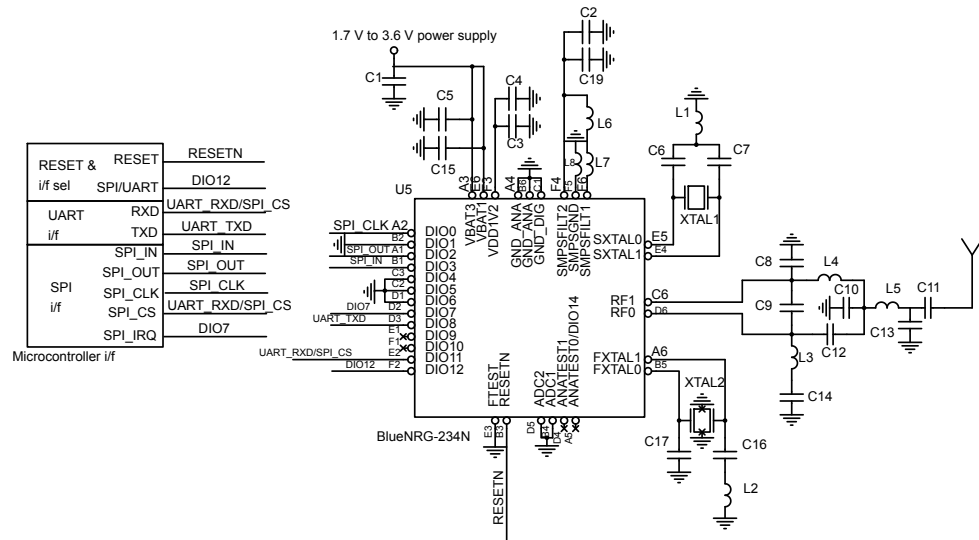

Figure 12. Application circuit: non active DC-DC converter WCSP34 package

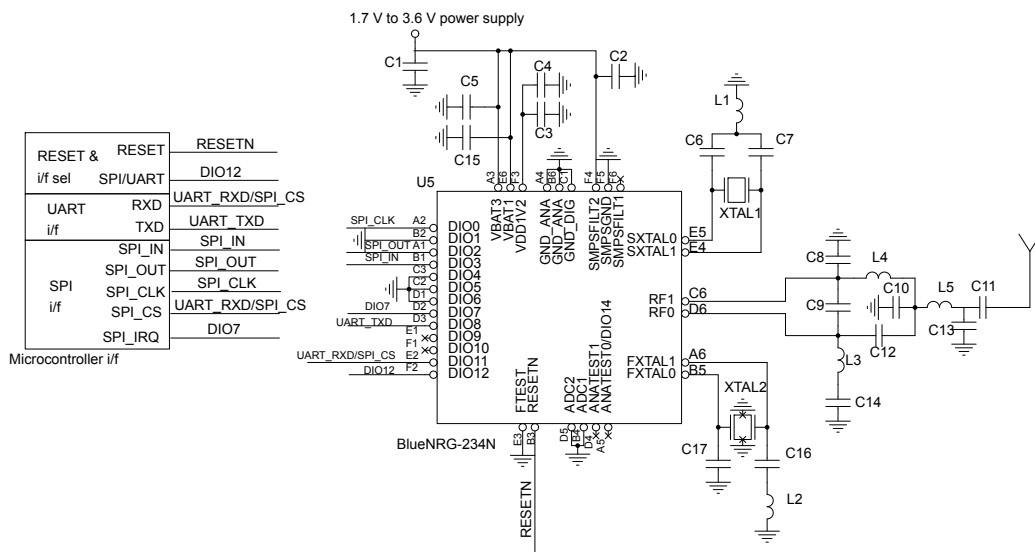

Figure 13. Application circuit: active DC-DC converter QFN32 package with BALF-NRG-02D3 balun

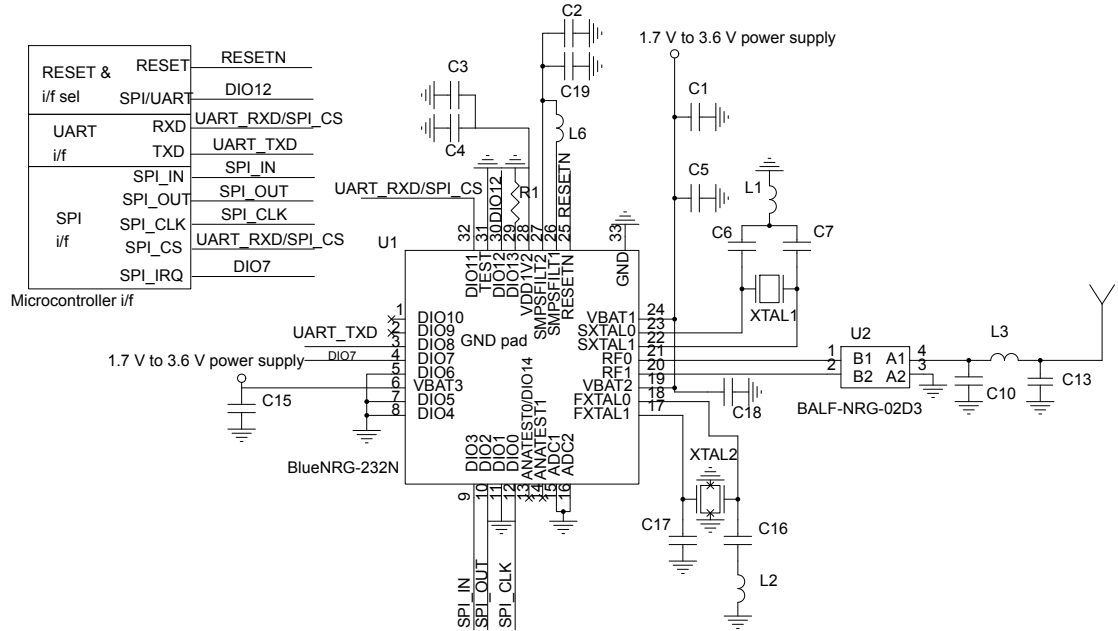

Table 4. External component list

Component	Description
C1	Decoupling capacitor
C2	DC-DC converter output capacitor
C3	Decoupling capacitor for 1.2 V digital regulator
C4	Decoupling capacitor for 1.2 V digital regulator
C5	Decoupling capacitor
C6	32 kHz crystal loading capacitor
C7	32 kHz crystal loading capacitor
C8	RF balun/matching network capacitor
C9	RF balun/matching network capacitor
C10	RF balun/matching network capacitor
C11	RF balun/matching network capacitor
C12	RF balun/matching network capacitor
C13	RF balun/matching network capacitor
C14	RF balun/matching network capacitor
C15	Decoupling capacitor
C16	32 MHz crystal loading capacitor
C17	32 MHz crystal loading capacitor
C18	Decoupling capacitor
C19	DC-DC converter output capacitor
L1	32 kHz crystal filter inductor
L2	32 MHz crystal filter inductor

Component	Description
L3	RF balun/matching network inductor
L4	RF balun/matching network inductor
L5	RF balun/matching network inductor
L6	SMPS inductor
L7	SMPS noise filter inductor (15 nH)
L8	SMPS ground noise filter inductor (3.4 nH)
XTAL1	32 kHz crystal (optional)
XTAL2	32 MHz crystal

5 Application controller interface

The application controller interface (ACI) is based on a standard UART/SPI module. The ACI defines a protocol providing access to all services offered by the layers of the embedded Bluetooth stack. ACI commands are described in the BlueNRG-232N ACI command interface documentation. In addition, ACI provides a set of commands that allow the BlueNRG-232N firmware to be programmed from an external device connected to SPI or UART.

The complete description of updater commands and procedures is provided in a separate application note.

6 External microcontroller interface

The BlueNRG-2N provides a hardware interface to external microcontroller based on two very common protocols:

- SPI slave protocol with interrupt signal
- UART

The selection between SPI or UART mode is done through the DIO12 pin. Refer to [Table 3. Pinout description](#), DIO12 description for UART, SPI selection options.

The physical layer (SPI or UART) is used to transfer commands and events between the external microcontroller and the BlueNRG-2N.

The commands and events are collectively named application control interface (ACI) and they are described in the BlueNRG-2N ACI documentation.

In addition, ACI provides a set of commands that allow the BlueNRG-2N firmware to be programmed/updated from an external device connected to SPI or UART.

6.1 UART interface

The characteristics of the UART interface are as follows:

- Baud rate: 115200
- Data bits: 8
- Parity: N
- Stop bits: 1
- Full duplex

The interface operates with logic levels as specified in [Table 12. Digital I/O specifications](#).

The UART interface does not allow the device to go to sleep state.

The pins dedicated to the UART interface are:

- DIO11 (UART RX)
- DIO8 (UART TX)

6.2 SPI interface

The characteristics of the SPI interface are the following:

- SPI clock: 1 MHz (max.)
- Data bits: 8
- Polarity: 0 (clock to 0 when idle)
- Phase: second edge
- Full duplex
- Slave mode

A dedicated IRQ pin is used to inform the external microcontroller that an event has occurred and the device needs attention.

The interface operates with logic levels as specified in [Table 11. Electrical characteristics](#).

The SPI interface allows the device to go into sleep state achieving the optimal power consumption.

6.3 SPI protocol specifications

This section describes the features and details of the SPI protocol provided by the BlueNRG-2N network coprocessor.

The features provided by the SPI protocol are:

- Power efficient
- Code efficient
- Fast data transfer

6.4 SPI protocol hardware details

The SPI port requires five pins:

- SPI clock
- SPI MOSI
- SPI MISO
- SPI CS
- SPI IRQ

The maximum SPI baud rate supported is 1 MHz. The timing diagram adopted is CPOL 0 and CPHA 1, which means data are captured on the SPI clock falling edge and data are changed on the rising edge. The SPI CS acts also as wake-up pin for the BlueNRG-2N, so that if the SPI CS pin is low (external uC selects the BlueNRG-2N for communication) the BlueNRG-2N is woken up if it was asleep. The BlueNRG-2N notifies event pending to the external uC through the SPI IRQ pin. If the SPI IRQ pin is high, the BlueNRG-2N has at least an event for the external uC.

Table 5. BlueNRG-2N SPI lines

Pin function	Pin name	Pin number		Information
		QFN32	WCSP34	
SPI clock	IO0	12	A2	SPI clock signal
SPI MOSI	IO2	10	A1	SPI master output slave input signal
SPI MISO	IO3	9	B1	SPI master input slave output signal
SPI CS	IO11	32	E2	SPI chip select signal/ wake-up signal
SPI IRQ	IO7	4	D2	SPI IRQ request for event pending signal

6.5 SPI communication protocol

To communicate with the BlueNRG-2N, the data on the SPI bus must be formatted as described in this section. An SPI transaction is defined from a falling edge of the SPI CS signal to the next rising edge of the SPI CS signal. Each SPI transaction must contain one data frame only. Each data frame should contain at least five bytes of header, and may have from 0 to N bytes of data.

Figure 14. Generic SPI transaction

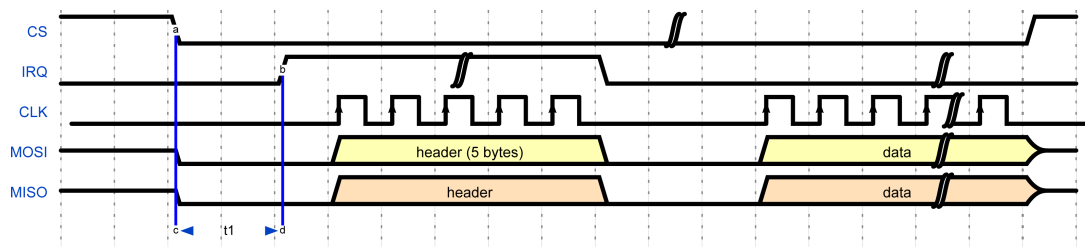

Figure 14. Generic SPI transaction shows a generic SPI transaction. The list of steps is as follows:

1. The external uC lowers the SPI CS signal to start the communication.
2. The BlueNRG-2N raises the SPI IRQ signal to indicate that it is ready for the communication. The time t_1 changes according to the state of the BlueNRG-2N. This time t_1 can include wakeup of the BlueNRG-2N and preparation of the header part of the frame.

3. The external uC must wait for the SPI IRQ signal to become high and then start to transfer the five bytes of the header that includes the control field with the intended operation. In addition, the external uC reads five bytes from the BlueNRG-2N, which include information about the actual size of the read and write buffer.
4. The external uC, after checking the five bytes of header, performs data transaction.
5. The BlueNRG-2N lowers SPI IRQ signal after the five byte headers are transferred, but due to internal processing, this could be done also during the data transfer phase.
6. The external uC must wait for the SPI IRQ to be low before raising the SPI CS signal to mark the end of the communication.

Some important notes are:

- Setting the SPI CS signal low wakes up the BlueNRG-2N if the device is asleep
- If the SPI IRQ signal is low before setting the SPI CS signal low, the BlueNRG-2N has no data events for the external uC, so the read buffer size is zero (RBUF=0)
- The time t_1 is the time between wake-up (point a in [Figure 14. Generic SPI transaction](#)) and the BlueNRG-2N ready to perform the SPI transaction (point b in [Figure 14. Generic SPI transaction](#)). The t_1 time range is from minimal value (the BlueNRG-2N already awakes when the SPI CS is asserted), to a maximum value that involves wake-up sequence and software boot
- Even if there are events pending after the end of the transaction, the SPI IRQ signal goes low to allow the BlueNRG-2N to update five byte headers and to re-arm the SPI for the next transaction (after this delay the SPI IRQ signal goes high again if events are pending)
- The SPI CS signal marks the beginning and end of the transaction
- The SPI CS high marks the end of the transaction and must be set to high only when IRQ line is low
- The gap between the header and the data is not mandatory, but it is normally required by the external uC to process the header and check if there is enough space in the buffers to perform the wanted transaction
- When the SPI IRQ signal is high, the five byte headers are locked and cannot be modified by the BlueNRG-2N firmware

Figure 15. SPI header format

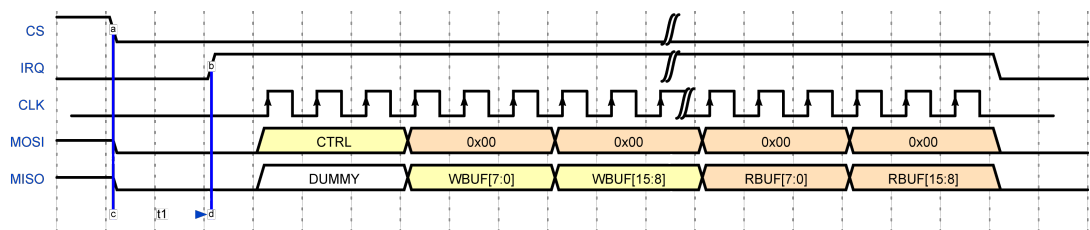

- The header of the external uC (the SPI master) is on the MOSI line, which is composed of one control byte (CTRL) and four bytes 0x00. CTRL field can have only the value of 0x0A (SPI write) or 0x0B (SPI read). The BlueNRG-2N returns the header on the MISO line at the same time. When the BlueNRG-2N asserts the SPI IRQ signal, it is ready. Otherwise, the BlueNRG-2N is still not initialized. The external uC must wait for the IRQ line to become high and perform a five bytes transaction.

The five bytes in the MISO line gives one byte of starting frame, two bytes with the size of the write buffer (WBUF) and two bytes with the size of the read buffer (RBUF). The endianness for WBUF and RBUF is LSB first. The value in WBUF means how many bytes the master can write to the BlueNRG-2N. The value in RBUF means how many bytes in the BlueNRG-2N are waiting to be read by the external uC

Read transaction

A read transaction is performed when the BlueNRG-2N raises the SPI IRQ line before the SPI CS signal is lowered by the external uC.

Figure 16. SPI read transaction

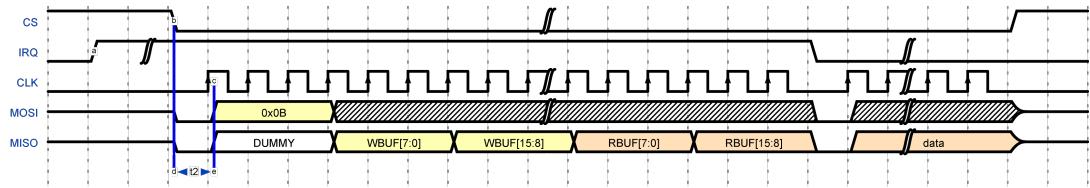

- In this case, the SPI IRQ signal is high indicating the BlueNRG-2N is awake and ready to perform the SPI transaction, after a hardware dependent set-up time t_2 (≥ 0.5 us). The transaction is performed as follows:
 - An event has been generated by the BlueNRG-2N (point a in Figure 16. SPI read transaction).
 - The external uC lowers the SPI CS signal to initiate a transaction (point b in Figure 16. SPI read transaction).
 - Since the SPI IRQ signal is high, the external uC initiates a data transfer after t_2 . The external uC transfers five bytes as follows [0x0B, XX, XX, XX, XX]. The WBUF and RBUF sizes are read by the SPI MISO signal.
 - The external uC performs the read data transaction for RBUF bytes. (Note: if RBUF is 0, this is an unexpected condition since the BlueNRG-2N is indicating that data is available; in any case the transaction needs to be completed by reading no bytes).
 - The BlueNRG-2N lowers SPI IRQ signal after the five bytes header are transferred, but due to internal processing, this could be done also during the data transfer phase.
 - The external uC must wait for the SPI IRQ to be low before raising the SPI CS signal to mark the end of the communication.

Write transaction

- A write transaction is performed by the external uC to send a command to the BlueNRG-2N. The BlueNRG-2N can be awakened or put to sleep when the SPI CS signal is lowered by the external uC. The assertion of the SPI CS signal wakes up the BlueNRG-2N, if asleep

Figure 17. SPI write transaction

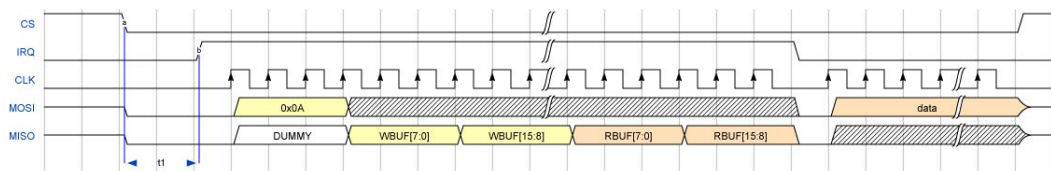

- The transaction is performed as follows:
 - The external uC lowers the SPI CS signal to initiate a transaction.
 - The BlueNRG-2N raises the SPI IRQ signal to indicate that it is ready with $t_1 \geq 0$.
 - The external uC waits for SPI IRQ signal to become high and start a transfer of five bytes sending the code of the intended operation and reading the read buffer and write buffer size. The external uC transfers five bytes as follows: [0x0A, XX, XX, XX, XX]. The WBUF and RBUF values are sampled in the SPI MISO signal.
 - The BlueNRG-2N lowers the SPI IRQ after the five byte headers are transferred, but due to internal processing, this could be done also during the data transfer phase.
 - The external uC checks if the WBUF allows sending the command. If yes, it performs the data transaction, otherwise it performs no data transfer (it would be possible to retry later.)
 - The external uC must wait for the SPI IRQ signal to be low before the communication is closed
 - The external uC must raise the SPI CS to mark the end of the transaction.

Error transaction

- This section lists the BlueNRG-2N firmware behavior when some error transactions are performed:
 - Incomplete header transaction (0 to 4): the BlueNRG-2N ignores the transaction
 - The external uC does not wait for the SPI IRQ signal to be low before raising the SPI CS signal: the BlueNRG-2N lowers the SPI IRQ signal when the SPI CS signal is high
 - The external uC does not wait for the SPI IRQ signal to be high before SPI clock starts: the result is acquisition of corrupted data both master and slave side
 - Incomplete read transaction: the master loses the event
 - Incomplete write transaction: the BlueNRG-2N stores the bytes written by the external uC. During the next write operation the BlueNRG-2N gets the new bytes trying to get a complete frame according to Bluetooth protocol
 - Two commands in a row without reading event for command: the BlueNRG-2N parses the two commands and then it generates the corresponding events

SPI state machine

- Hereafter the description of the BlueNRG-2N SPI state machine

Table 6. BlueNRG-2N SPI state machine states

State	Description	Input	Output	Next state
Init	Boot/transient state Hardware initialization	-	IRQ=0	Configured
Configured	Ready to transfer information, 5 byte header frozen	CS=0	IRQ=1	Waiting_Header
		CS=1 Event pending=0	IRQ=0	Sleep
		CS=1 Event pending=1	IRQ=1	Configured
Sleep	Sleep state with almost all logic off	CS=1 Event pending=0	IRQ=0	Sleep
		CS=1 Event pending=1	IRQ=0	Configured
		CS=0	IRQ=0	Configured
Waiting_Header	Receiving 5 byte header from SPI master	CS=0	IRQ=1	When 5-byte are received goes to Header_Received
		CS=1	IRQ=1	Transaction_Complete
Header_Received	5 byte header received	CS=0	IRQ=0	Waiting_Data
		CS=1	IRQ=0	Transaction_Complete
Waiting_Data	Receiving payload	CS=0	IRQ=0	Waiting_Data
		nCS=1	IRQ=0	Transaction_Complete
Transaction_Complete	Transitional	nCS=1	IRQ=0	Configured

Figure 18. SPI protocol state machine

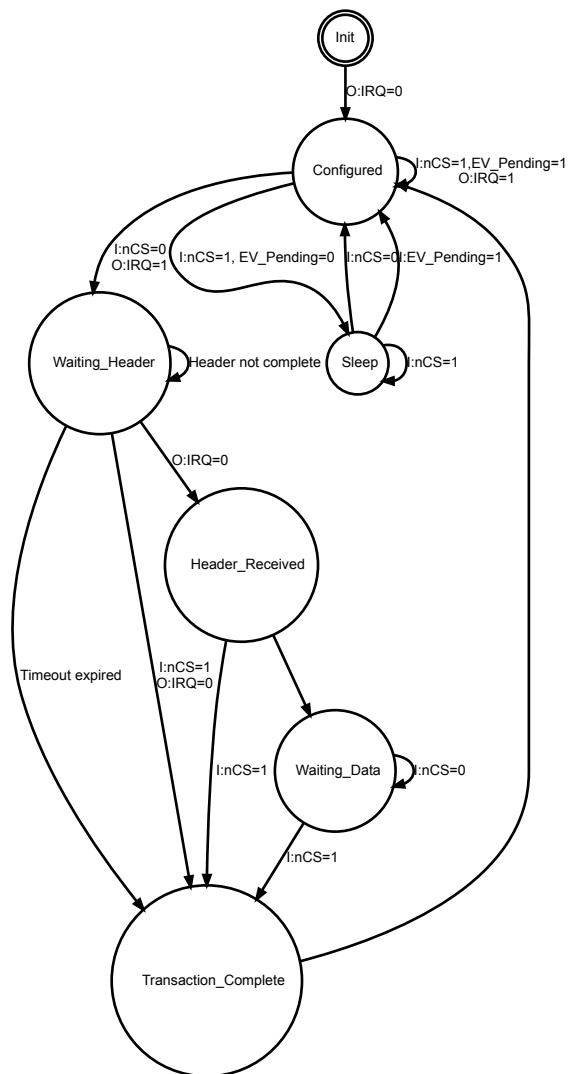

External uC behavior

- The external uC must act according to the information from the BlueNRG-2N:
 - SPI IRQ signal
 - Information from header frame WBUF and RBUF

Table 7. BlueNRG-2N SPI inputs

Input from BlueNRG-1	Meaning	External uC
IRQ=1, RBUF is not 0	Read operation is required, at least one event pending	Read operation can be performed
IRQ=0, RBUF is 0	No event pending	Nothing to do
IRQ=0, RBUF is 0, WBUF is N	No event pending	If the number of bytes to write is lesser or equal than N, then write operation is acceptable. Otherwise, the extent uC must wait

Figure 19. Expected uC SPI protocol state machine

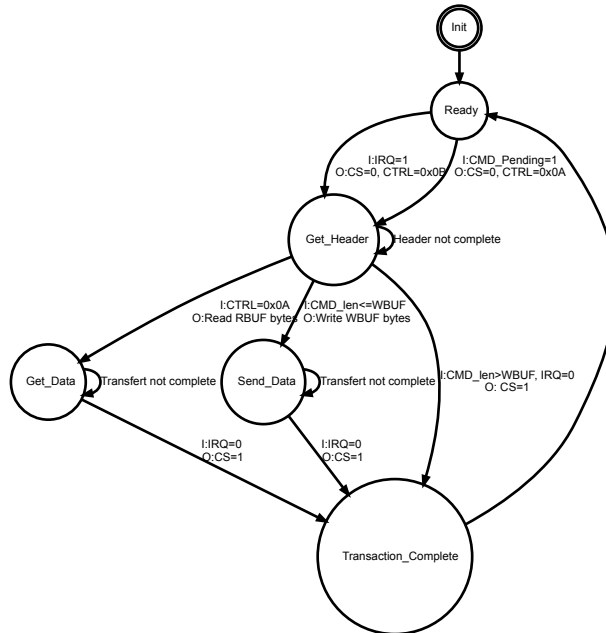

Figure 20. HCI_READ_LOCAL_VERSION_INFORMATION SPI waveform

From STANDBY state, HCI_READ_LOCAL_VERSION_INFORMATION

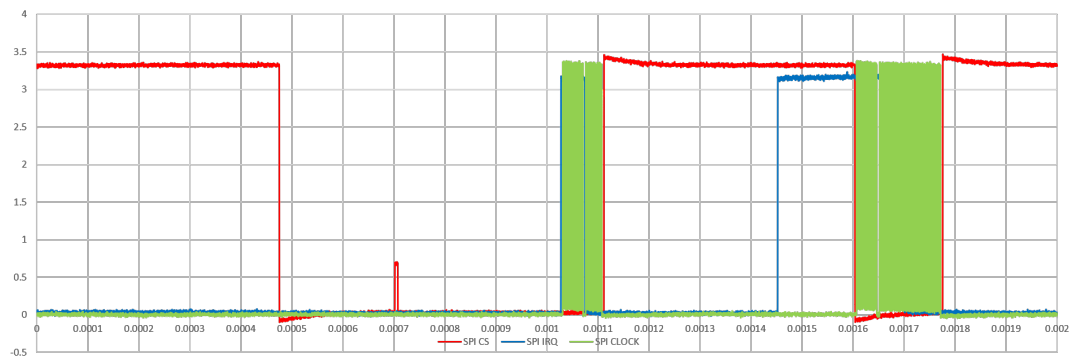

Figure 21. HCI_READ_LOCAL_VERSION_INFORMATION SPI waveform zoom

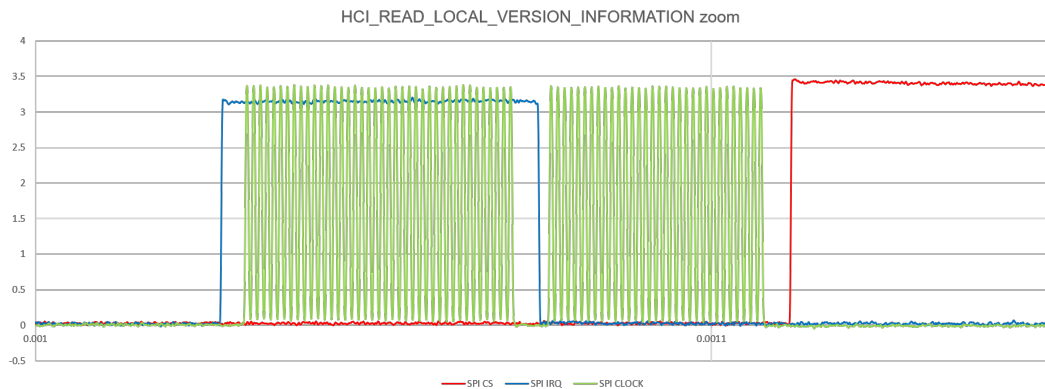
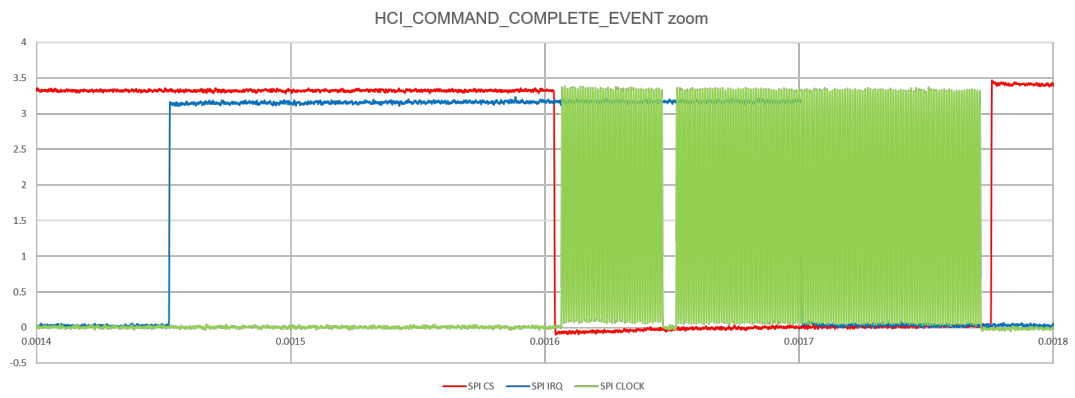

Figure 22. HCI_COMMAND_COMPLETE_EVENT SPI waveform



7 Absolute maximum ratings and thermal data

Table 8. Absolute maximum ratings

Pin	Parameter	Value	Unit
VBAT3, VBAT2, VBAT1, RESETN, SMPSFILT1, SMPSFILT2	DC-DC converter supply voltage input and output	-0.3 to +3.9	V
VDD1V2	DC voltage on linear voltage regulator	-0.3 to +1.3	V
DIO0 to DIO25, TEST	DC voltage on digital input/output pins	-0.3 to +3.9	V
ANATEST0, ANATEST1, ADC1, ADC2	DC voltage on analog pins	-0.3 to +3.9	V
FXTAL0, FXTAL1, SXTAL0, SXTAL1	DC voltage on XTAL pins	-0.3 to +1.4	V
RF0, RF1	DC voltage on RF pins	-0.3 to +1.4	V
TSTG	Storage temperature range	-40 to +125	°C
VESD-HBM	Electrostatic discharge voltage	±2.0	kV

Note: Absolute maximum ratings are those values above which damage to the device may occur. Functional operation under these conditions is not implied. All voltages are referred to GND.

Table 9. Thermal data

Symbol	Parameter	Value	Unit
Rthj-amb	Thermal resistance junction-ambient	34 (QFN32)	°C/W
		50 (WLCSP34)	
Rthj-c	Thermal resistance junction-case	2.5 (QFN32)	°C/W
		25 (WLCSP34)	

8 General characteristics

Table 10. Operating conditions

Symbol	Parameter	Min.	Typ.	Max.	Unit
V _{BAT}	Operating battery supply voltage	1.7		3.6	V
T _A	Operating Ambient temperature range	-40		+105	°C

9 Electrical specifications

9.1 Electrical characteristics

Characteristics measured over recommended operating conditions unless otherwise specified. Typical values are referred to $T_A = 25\text{ }^\circ\text{C}$, $V_{BAT} = 3.0\text{ V}$. All performance data are referred to a $50\text{ }\Omega$ antenna connector, via reference design, QFN32 package version.

Table 11. Electrical characteristics

Symbol	Parameter	Test conditions	Min.	Typ.	Max.	Unit
Power consumption when DC-DC converter active						
I_{BAT}	Supply current	Reset	–	5	–	nA
		Standby	–	500	–	nA
		Sleep mode: 32 kHz XO ON (24 KB retention RAM)	–	0.9	–	μA
		Sleep mode: 32 kHz RO ON (24 KB retention RAM)		2.1		
		Active mode: CPU, Flash and RAM on	–	1.9	–	mA
		RX	–	7.7	–	mA
		TX +8 dBm	–	15.1	–	mA
		TX +4 dBm		10.9		
		TX +2 dBm		9		
		TX -2 dBm		8.3		
		TX -5 dBm		7.7		
		TX -8 dBm		7.1		
		TX -11 dBm		6.8		
		TX -14 dBm		6.6		
Power consumption when DC-DC converter not active						
I_{BAT}	Supply current	Reset	–	5	–	nA
		Standby	–	500	–	nA
		Sleep mode: 32 kHz XO ON (24 KB retention RAM)	–	0.9	–	μA
		Sleep mode: 32 kHz RO ON (24 KB retention RAM)		2.1		
		Active mode: CPU, Flash and RAM on	–	3.3	–	mA
I_{BAT}	Supply current	RX	–	14.5	–	mA
		TX +8 dBm	–	28.8		mA
		TX +4 dBm		20.5		
		TX +2 dBm		17.2		
		TX -2 dBm		15.3		
		TX -5 dBm		14		
		TX -8 dBm		13		
		TX -11 dBm		12.3		
		TX -14 dBm		12		

Table 12. Digital I/O specifications

Symbol	Test conditions	Min.	Typ.	Max.	Unit
T(RST)L			1.5		ms
TC			3.3		V
TC1			2.5		V
TC2			1.8		V
VIL				0.3*VDD	V
VIH		0.65*VDD			V
VOL	IOL = 3 mA			0.4	V
VOH	IOH = 3 mA	0.7*VDD			V
IOL (low drive strength)	TC (VOL = 0.4 V)		5.6		mA
	TC1 (VOL = 0.42 V)		6.6		mA
	TC2 (VOL = 0.45 V)		3		mA
IOL (high drive strength)	TC (VOL = 0.4 V)		11.2		mA
	TC1 (VOL = 0.42 V)		13.2		mA
	TC2 (VOL = 0.45 V)		6		mA
IOL (Very high drive strength)	TC (VOL = 0.4 V)		16.9		mA
	TC1 (VOL = 0.42 V)		19.9		mA
	TC2 (VOL = 0.45 V)		9.2		mA
IOH (low drive strength)	TC (VOH = 2.4 V)		10.6		mA
	TC1 (VOH = 1.72 V)		7.2		mA
	TC2 (VOH = 1.35 V)		3		mA
IOH (high drive strength)	TC (VOH = 2.4 V)		19.2		mA
	TC1 (VOH = 1.72 V)		12.9		mA
	TC2 (VOH = 1.35 V)		5.5		mA
IOH (very high drive strength)	TC (VOH = 2.4 V)		29.4		mA
	TC1 (VOH = 1.72 V)		19.8		mA
	TC2 (VOH = 1.35 V)		8.4		mA
IPUD (current sourced/sunked from IOs with pull enabled)	Static supply 1.7 V	5		10	μA
	Static supply 3.6 V	40		60	μA

9.2 RF general characteristics

Characteristics measured over recommended operating conditions unless otherwise specified. Typical values are referred to $T_A = 25\text{ }^\circ\text{C}$, $V_{BAT} = 3.0\text{ V}$. All performance data are referred to a $50\ \Omega$ antenna connector, via reference design, QFN32 package version.

Table 13. RF general characteristics

Symbol	Parameter	Test conditions	Min.	Typ.	Max.	Unit
FREQ	Frequency range		2400	–	2483.5	MHz
FCH	Channel spacing		–	2	–	MHz
RFch	RF channel center frequency		2402	–	2480	MHz

9.3 RF transmitter characteristics

Characteristics measured over recommended operating conditions unless otherwise specified. Typical values are referred to $T_A = 25\text{ }^\circ\text{C}$, $V_{BAT} = 3.0\text{ V}$. All performance data are referred to a $50\text{ }\Omega$ antenna connector, via reference design, QFN32 package version.

Table 14. RF transmitter characteristics

Symbol	Parameter	Test conditions	Min.	Typ.	Max.	Unit
MOD	Modulation scheme		GFSK			
BT	Bandwidth-bit period product		–	0.5	–	
Mindex	Modulation index		–	0.5	–	
DR	Air data rate		–	1	–	Mbps
PMAX	Maximum output power	At antenna connector	–	+8	+10	dBm
PRFC	Minimum output power		–	-16.5	–	dBm
PBW1M	6 dB bandwidth for modulated carrier (1 Mbps)	Using resolution bandwidth of 100 kHz	500	–	–	kHz
PRF1	1 st adjacent channel transmit power 2 MHz	Using resolution bandwidth of 100 kHz and average detector	–	-35	–	dBm
PRF2	2 nd Adjacent channel transmit power >3 MHz	Using resolution bandwidth of 100 kHz and average detector	–	-40	–	dBm
ZLOAD	Optimum differential load	@ 2440 MHz	–	25.4 + j20.8 ⁽¹⁾	–	Ω

1. Simulated value.

9.4 RF receiver characteristics

Characteristics measured over recommended operating conditions unless otherwise specified. Typical values are referred to $T_A = 25\text{ }^\circ\text{C}$, $V_{BAT} = 3.0\text{ V}$. All performance data are referred to a $50\text{ }\Omega$ antenna connector, via reference design, QFN32 package version.

Table 15. RF receiver characteristics

Symbol	Parameter	Test conditions	Min.	Typ.	Max.	Unit
RXSENS	Sensitivity	BER <0.1%		-88		dBm
PSAT	Saturation	BER <0.1%		11		dBm
zIN	Input differential impedance	@ 2440 MHz		25.5-j14.2		Ω
RF selectivity with BLE equal modulation on interfering signal						
C/ICO-channel	Co-channel interference	Wanted signal = -67 dBm, BER ≤ 0.1%		6		dBc
C/I1 MHz	Adjacent (+1 MHz) interference	Wanted signal = -67 dBm, BER ≤ 0.1%		0		dBc
C/I2 MHz	Adjacent (+2 MHz) interference	Wanted signal = -67 dBm, BER ≤ 0.1%		-40		dBc
C/I3 MHz	Adjacent (+3 MHz) interference	Wanted signal = -67 dBm, BER ≤ 0.1%		-47		dBc
C/I≥4 MHz	Adjacent (≥ ± 4 MHz) interference	Wanted signal = -67 dBm, BER ≤ 0.1%		-46		dBc
C/I≥6 MHz	Adjacent (≥ ± 6 MHz) interference	Wanted signal = -67 dBm BER ≤ 0.1%		-48		dBc

Symbol	Parameter	Test conditions	Min.	Typ.	Max.	Unit
C/I \geq 25 MHz	Adjacent (\geq 25 MHz) interference	Wanted signal = -67 dBm, BER \leq 0.1%		-70		dBc
C/I _{Image}	Image frequency interference -2 MHz	Wanted signal = -67 dBm, BER \leq 0.1%		-16		dBc
C/I _{Image} \pm 1 MHz	Adjacent (\pm 1 MHz) interference to in-band image frequency -1 MHz -3 MHz	Wanted signal = -67 dBm, BER \leq 0.1%		0 -23		dBc
Intermodulation characteristics (CW signal at f_1, BLE interfering signal at f_2)						
P_IM(3)	Input power of IM interferes at 3 and 6 MHz distance from wanted signal	Wanted signal = -64 dBm, BER \leq 0.1%		-34		dBm
P_IM(-3)	Input power of IM interferes at -3 and -6 MHz distance from wanted signal	Wanted signal = -64 dBm, BER \leq 0.1%		-48		dBm
P_IM(4)	Input power of IM interferes at \pm 4 and \pm 8 MHz distance from wanted signal	Wanted signal = -64 dBm, BER \leq 0.1%		-34		dBm
P_IM(5)	Input power of IM interferes at \pm 5 and \pm 10 MHz distance from wanted signal	Wanted signal = -64 dBm, BER \leq 0.1%		-34		dBm

9.5 High speed crystal oscillator characteristics

Characteristics measured over recommended operating conditions unless otherwise specified. Typical values are referred to $T_A = 25^\circ\text{C}$, $V_{BAT} = 3.0\text{ V}$.

Table 16. High speed crystal oscillator characteristics

Symbol	Parameter	Test conditions	Min.	Typ.	Max.	Unit
f _{NOM}	Nominal frequency		-	16/32	-	MHz
f _{TOL}	Frequency tolerance	Includes initial accuracy, stability over temperature, aging and frequency pulling due to incorrect load capacitance	-	-	\pm 50	ppm
ESR	Equivalent series resistance		-	-	100	Ω
PD	Drive level		-	-	100	μW

9.6 High speed crystal oscillator

The BlueNRG-2N includes a fully integrated low power 16/32 MHz Xtal oscillator with an embedded amplitude regulation loop. In order to achieve low power operation and good frequency stability of the XTAL oscillator, certain considerations with respect to the quartz load capacitance C_0 need to be taken into account.

Figure 23. High speed oscillator block diagram shows a simplified block diagram of the amplitude regulated oscillator used on the BlueNRG-2N.

Figure 23. High speed oscillator block diagram

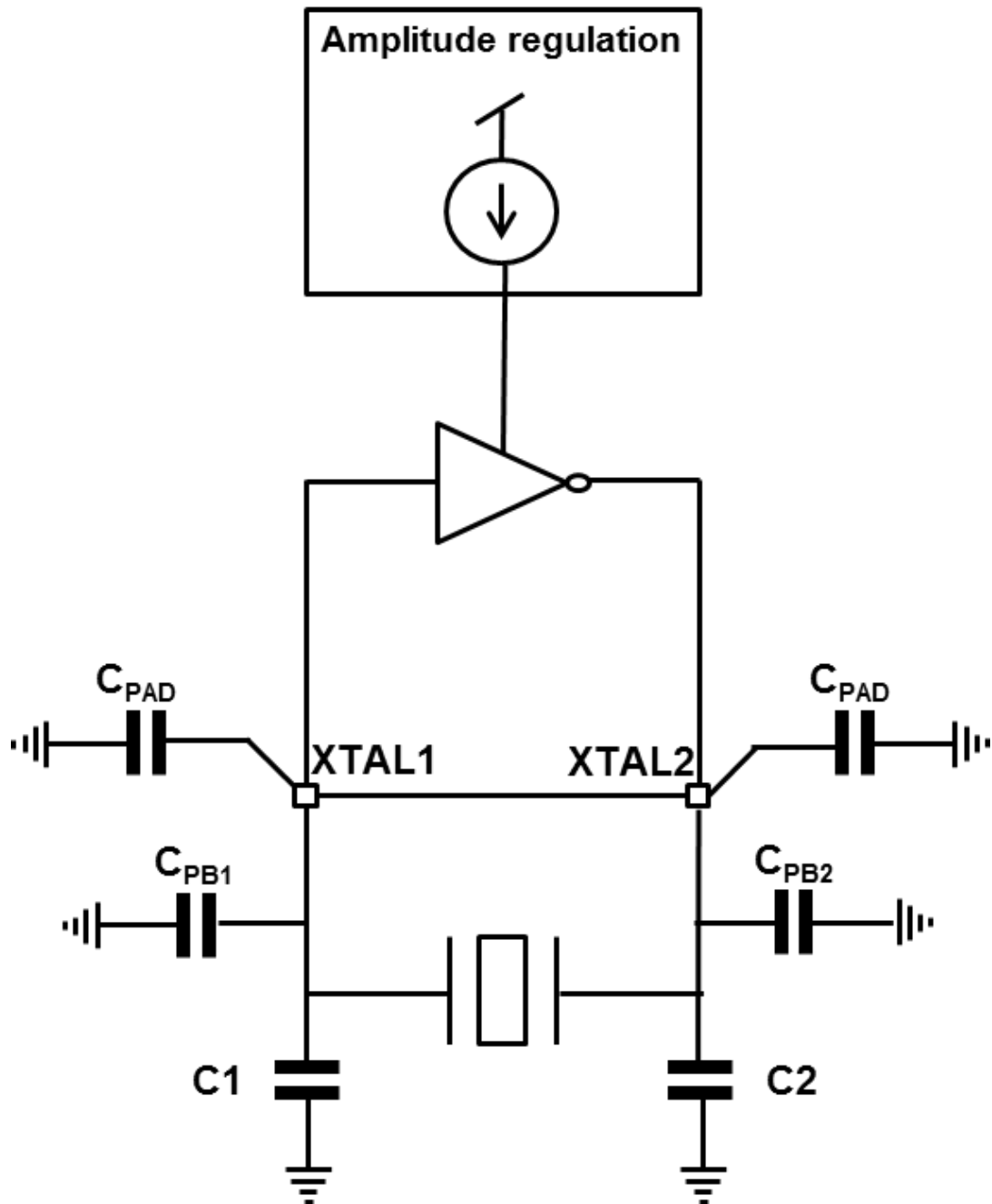

Low power consumption and fast start-up time is achieved by choosing a quartz crystal with a low load capacitance C_0 . A reasonable choice for capacitor C_0 is 12 pF. To achieve good frequency stability, the following equation needs to be satisfied:

$$C_0 = \frac{C_1 * C_2'}{C_1 + C_2'} \quad (1)$$

Where $C_1' = C_1 + C_{PCB1} + C_{PAD}$, $C_2' = C_2 + C_{PCB2} + C_{PAD}$, where C_1 and C_2 are external (SMD) components, C_{PCB1} and C_{PCB2} are PCB routing parasites and C_{PAD} is the equivalent small-signal pad-capacitance. The value of C_{PAD} is around 0.5 pF for each pad. The routing parasites should be minimized by placing quartz and C_1/C_2 capacitors close to the chip, not only for an easier matching of the load capacitance C_0 , but also to ensure robustness against noise injection. Connect each capacitor of the Xtal oscillator to ground by a separate vias.

9.7 Low speed crystal oscillator characteristics

Characteristics measured over recommended operating conditions unless otherwise specified. Typical values are referred to $T_A = 25\text{ }^\circ\text{C}$, $V_{BAT} = 3.0\text{ V}$.

Table 17. Low speed crystal oscillator characteristics

Symbol	Parameter	Test conditions	Min.	Typ.	Max.	Unit
f _{NOM}	Nominal frequency		–	32.768	–	kHz
f _{TOL}	Frequency tolerance	Includes initial accuracy, stability over temperature, aging and frequency pulling due to incorrect load capacitance.	–	–	±50	ppm
ESR	Equivalent series resistance		–	–	90	kΩ
PD	Drive level		–	–	0.1	μW

Note: These values are the correct ones for NX3215SA-32.768 kHz-EXS00A-MU00003.

9.8 High speed ring oscillator characteristics

Characteristics measured over recommended operating conditions unless otherwise specified. Typical values are referred to $T_A = 25\text{ }^\circ\text{C}$, $V_{BAT} = 3.0\text{ V}$.

Table 18. High speed ring oscillator characteristics

Symbol	Parameter	Test conditions	Min.	Typ.	Max.	Unit
f _{NOM}	Nominal frequency		–	14	–	MHz

9.9 Low speed ring oscillator characteristics

Characteristics measured over recommended operating conditions unless otherwise specified. Typical values are referred to $T_A = 25\text{ }^\circ\text{C}$, $V_{BAT} = 3.0\text{ V}$, QFN32 package version.

Table 19. Low speed ring oscillator characteristics

Symbol	Parameter	Test conditions	Min.	Typ.	Max.	Unit
32 kHz ring oscillator (LSROSC)						
f _{NOM}	Nominal frequency		–	32	–	kHz

9.10 N-fractional frequency synthesizer characteristics

Characteristics measured over recommended operating conditions unless otherwise specified. Typical values are referred to $T_A = 25\text{ }^\circ\text{C}$, $V_{BAT} = 3.0\text{ V}$, $f_c = 2440\text{ MHz}$.

Table 20. N-Fractional frequency synthesizer characteristics

Symbol	Parameter	Test conditions	Min.	Typ.	Max.	Unit
PNSYNTH	RF carrier phase noise	At ±1 MHz offset from carrier	–	-113	–	dBc/Hz
		At ±3 MHz offset from carrier	–	-119	–	dBc/Hz
LOCKTIME	PLL lock time		–	–	40	μs
TOTIME	PLL turn-on / hop time	Including calibration	–	–	150	μs

10 Package information

In order to meet environmental requirements, ST offers these devices in different grades of **ECOPACK** packages, depending on their level of environmental compliance. ECOPACK specifications, grade definitions and product status are available at: www.st.com. ECOPACK is an ST trademark.

10.1 QFN32 package information

Figure 24. QFN32 (5 x 5 x 1 pitch 0.5 mm) package outline

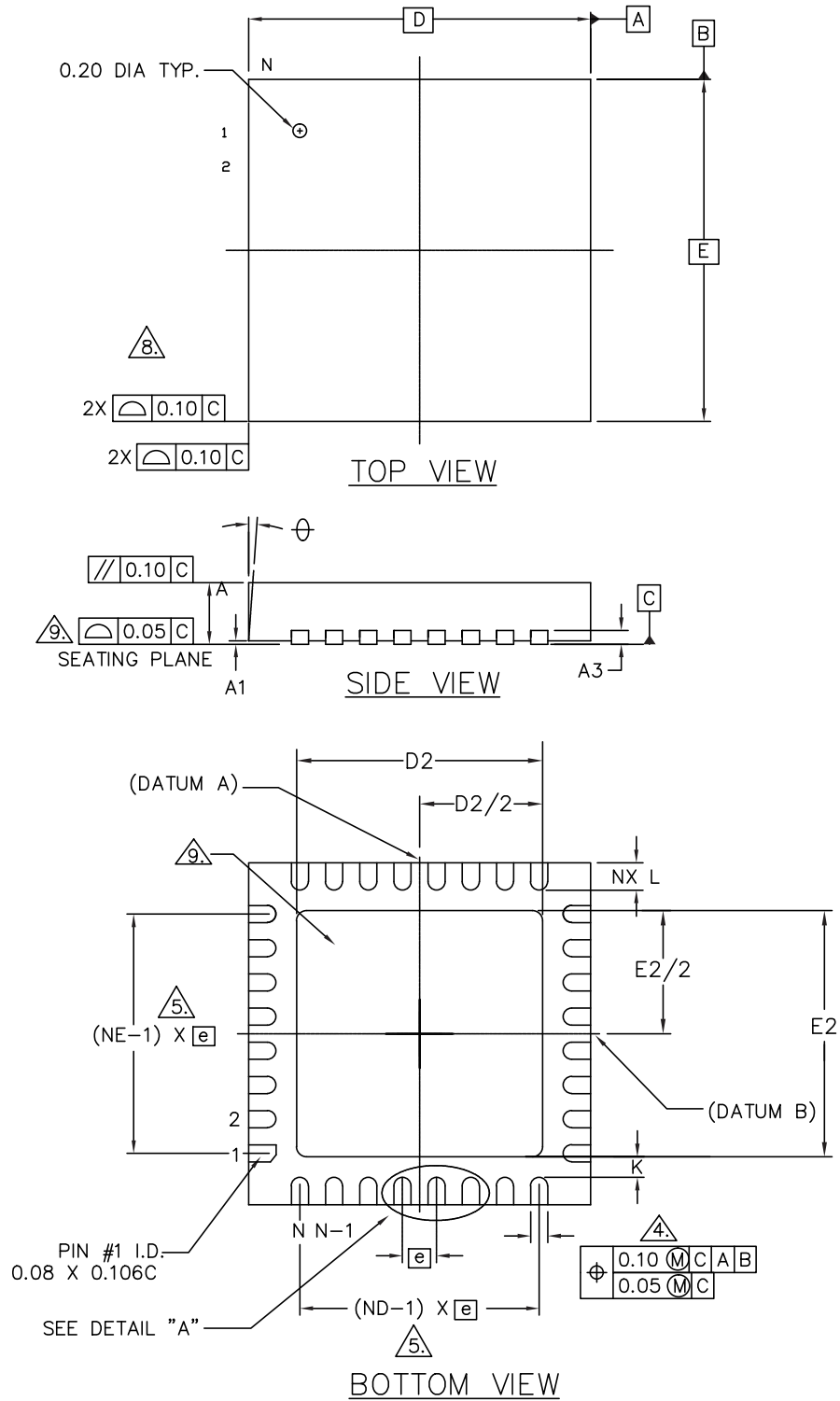

QFN32_POA_8362854_B

Table 21. QFN32 (5 x 5 x 1 pitch 0.5 mm) mechanical data

Dim.	mm		
	Min.	Typ.	Max.
A	0.80	0.85	1.00
A1	0	0.02	0.05
A3	0.20 REF		
b	0.18	0.25	0.30
D	5.00 BSC		
E	5.00 BSC		
D2	3.2		3.70
E2	3.2		3.70
e	0.5 BSC		
L	0.30	0.40	0.50
Φ	0°		14°
K	0.20		

Figure 25. QFN32 (5 x 5 x 1 pitch 0.5 mm) package detail "A"

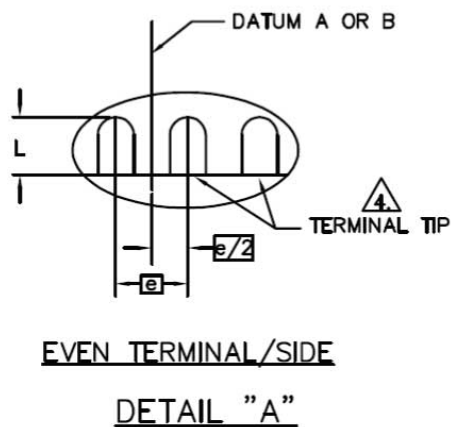

10.2 WLCSP34 package information

Figure 26. WLCSP34 (2.66 x 2.56 x 0.5 pitch 0.4 mm) package outline

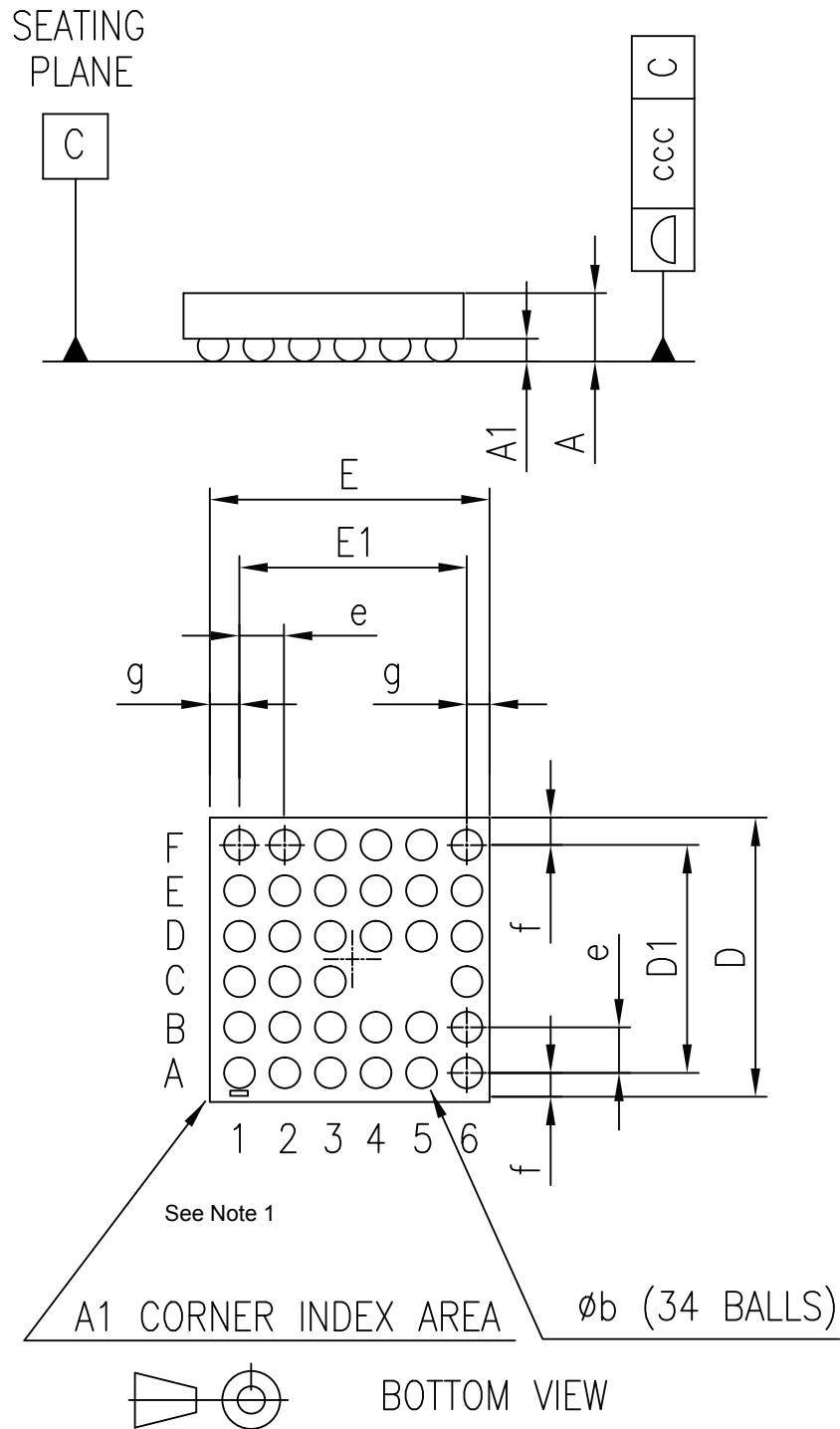

WLCSP34_POA_8165249

1. The corner of terminal A1 must be identified on the top surface by using a laser marking dot.

Table 22. WLCSP34 (2.66 x 2.56 x 0.5 pitch 0.4 mm) mechanical data

Dim.	mm.			Notes
	Min.	Typ.	Max.	
A			0.50	
A1		0.20		
b		0.27		(1)
D	2.50	2.56	2.58	(2)
D1		2.00		
E	2.60	2.66	2.68	(3)
E1		2.00		
e		0.40		
f		0.28		
g		0.33		
ccc			0.05	

1. The typical ball diameter before mounting is 0.25 mm.
2. $D = f + D1 + f$.
3. $E = g + E1 + g$.

11 PCB assembly guidelines

For Flip Chip mounting on the PCB, STMicroelectronics recommends the use of a solder stencil aperture of 330 x 330 μm maximum and a typical stencil thickness of 125 μm .

Flip Chips are fully compatible with the use of near eutectic 95.8% Sn, 3.5% Ag, 0.7% Cu solder paste with no-clean flux. ST's recommendations for Flip-Chip board mounting are illustrated on the soldering reflow profile shown in Figure 27. Flip Chip CSP (2.71 x 2.58 x 0.5 pitch 0.4 mm) package reflow profile recommendation.

Figure 27. Flip Chip CSP (2.71 x 2.58 x 0.5 pitch 0.4 mm) package reflow profile recommendation

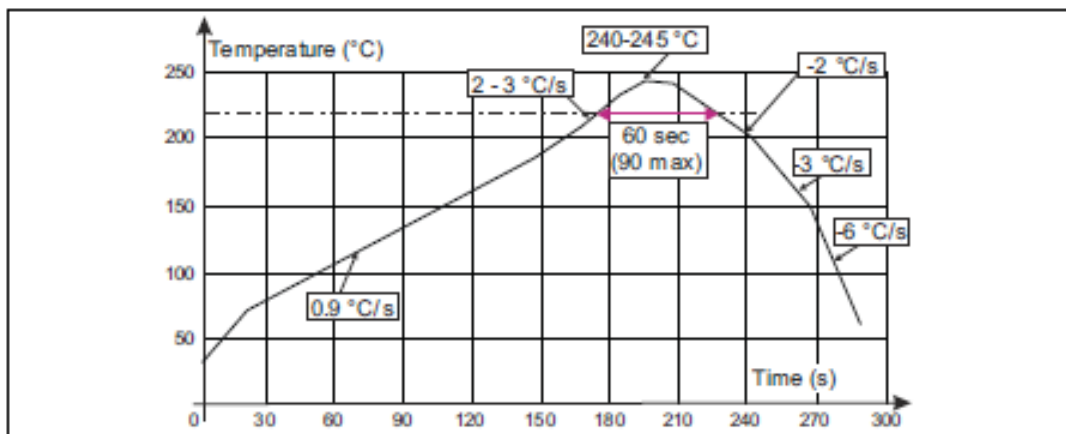

Table 23. Flip Chip CSP (2.71 x 2.58 x 0.5 pitch 0.4 mm) package reflow profile recommendation

Profile	Value	
	Typ.	Max.
Temp. gradient in preheat (T = 70 - 180 °C/s)	0.9 °C/s	3 °C/s
Temp. gradient (T = 200 - 225 °C)	2 °C/s	3 °C/s
Peak temp. in reflow	240 - 245 °C	260 °C
Time above 200 °C	60 s	90 s
Temp. gradient in cooling	-2 to -3 °C	-6 °C/s
Time from 50 to 220 °C	160 to 220 °C	

Dwell time in the soldering zone (with temperature higher than 220 °C) has to be kept as short as possible to prevent component and substrate damage. Peak temperature must not exceed 260 °C. Controlled atmosphere (N₂ or N₂H₂) is recommended during the whole reflow, especially above 150 °C.

Flip Chips are able to withstand three times the previous recommended reflow profile to be compatible with a double reflow when SMDs are mounted on both sides of the PCB plus one additional repair.

A maximum of three soldering reflows are allowed for these lead-free packages (with repair step included).

The use of a no-clean paste is highly recommended to avoid any cleaning operation. To prevent any bump cracks, ultrasonic cleaning methods are not recommended.

12 Ordering information

Table 24. Ordering information

Order code	Package	Packing
BlueNRG-232N	QFN32 (5x5 mm)	Tape and reel
BlueNRG-234N	WLCSP34 (2.66x2.56 mm)	

Revision history

Table 25. Document revision history

Date	Version	Changes
09-Jul-2020	1	Initial release.
17-Sep-2020	2	Updated features in cover page.

Contents

1	High performance and benefits	3
2	Functional details	4
2.1	Core	4
2.2	Power management	4
2.2.1	State description	4
2.3	Clocks and reset management	5
2.3.1	Reset management	6
2.4	TX/RX event alert	8
2.5	SWD debug feature	8
2.6	Bluetooth low energy radio	8
2.6.1	Radio operating modes	8
2.7	Pre-programmed bootloader	9
2.8	Firmware image	9
2.9	Unique device serial number	9
3	Pin description	10
4	Application circuit	14
5	Application controller interface	18
6	External microcontroller interface	19
6.1	UART interface	19
6.2	SPI interface	19
6.3	SPI protocol specifications	19
6.4	SPI protocol hardware details	20
6.5	SPI communication protocol	20
7	Absolute maximum ratings and thermal data	27
8	General characteristics	28
9	Electrical specifications	29
9.1	Electrical characteristics	29
9.2	RF general characteristics	30
9.3	RF transmitter characteristics	31

9.4	RF receiver characteristics	31
9.5	High speed crystal oscillator characteristics	32
9.6	High speed crystal oscillator	32
9.7	Low speed crystal oscillator characteristics	34
9.8	High speed ring oscillator characteristics	34
9.9	Low speed ring oscillator characteristics	34
9.10	N-fractional frequency synthesizer characteristics	34
10	Package information	35
10.1	[Package name] package information	36
10.2	WLCSP34 package information	38
11	PCB assembly guidelines	40
12	Ordering information	41
	Revision history	42

List of tables

Table 1.	Relationship between the BlueNRG-2N states and functional blocks	5
Table 2.	SWD port	8
Table 3.	Pinout description	12
Table 4.	External component list	16
Table 5.	BlueNRG-2N SPI lines	20
Table 6.	BlueNRG-2N SPI state machine states	23
Table 7.	BlueNRG-2N SPI inputs	24
Table 8.	Absolute maximum ratings	27
Table 9.	Thermal data	27
Table 10.	Operating conditions	28
Table 11.	Electrical characteristics	29
Table 12.	Digital I/O specifications	30
Table 13.	RF general characteristics	30
Table 14.	RF transmitter characteristics	31
Table 15.	RF receiver characteristics	31
Table 16.	High speed crystal oscillator characteristics	32
Table 17.	Low speed crystal oscillator characteristics	34
Table 18.	High speed ring oscillator characteristics	34
Table 19.	Low speed ring oscillator characteristics	34
Table 20.	N-Fractional frequency synthesizer characteristics	34
Table 21.	QFN32 (5 x 5 x 1 pitch 0.5 mm) mechanical data	37
Table 22.	WLCSP34 (2.66 x 2.56 x 0.5 pitch 0.4 mm) mechanical data	39
Table 23.	Flip Chip CSP (2.71 x 2.58 x 0.5 pitch 0.4 mm) package reflow profile recommendation	40
Table 24.	Ordering information	41
Table 25.	Document revision history	42

List of figures

Figure 1.	BlueNRG-2N network processor RF software layers	3
Figure 2.	BlueNRG-2N power management state machine	4
Figure 3.	Reset and wake-up generation	6
Figure 4.	BlueNRG-2N power-up sequence	7
Figure 5.	Reset circuit	7
Figure 6.	BlueNRG-2N pinout top view (QFN32)	10
Figure 7.	BlueNRG-2N ball out top view (WCSP34)	11
Figure 8.	BlueNRG-2N ball out bottom view (WCSP34)	12
Figure 9.	Application circuit: active DC-DC converter QFN32 package	14
Figure 10.	Application circuit: non-active DC-DC converter QFN32 package	14
Figure 11.	Application circuit: active DC-DC converter WCSP34 package	15
Figure 12.	Application circuit: non active DC-DC converter WCSP34 package	15
Figure 13.	Application circuit: active DC-DC converter QFN32 package with BALF-NRG-02D3 balun	16
Figure 14.	Generic SPI transaction	20
Figure 15.	SPI header format	21
Figure 16.	SPI read transaction	22
Figure 17.	SPI write transaction	22
Figure 18.	SPI protocol state machine	24
Figure 19.	Expected uC SPI protocol state machine	25
Figure 20.	HCI_READ_LOCAL_VERSION_INFORMATION SPI waveform	25
Figure 21.	HCI_READ_LOCAL_VERSION_INFORMATION SPI waveform zoom	25
Figure 22.	HCI_COMMAND_COMPLETE_EVENT SPI waveform	26
Figure 23.	High speed oscillator block diagram	33
Figure 24.	QFN32 (5 x 5 x 1 pitch 0.5 mm) package outline	36
Figure 25.	QFN32 (5 x 5 x 1 pitch 0.5 mm) package detail "A"	37
Figure 26.	WLCSP34 (2.66 x 2.56 x 0.5 pitch 0.4 mm) package outline	38
Figure 27.	Flip Chip CSP (2.71 x 2.58 x 0.5 pitch 0.4 mm) package reflow profile recommendation	40

IMPORTANT NOTICE – PLEASE READ CAREFULLY

STMicroelectronics NV and its subsidiaries (“ST”) reserve the right to make changes, corrections, enhancements, modifications, and improvements to ST products and/or to this document at any time without notice. Purchasers should obtain the latest relevant information on ST products before placing orders. ST products are sold pursuant to ST’s terms and conditions of sale in place at the time of order acknowledgement.

Purchasers are solely responsible for the choice, selection, and use of ST products and ST assumes no liability for application assistance or the design of Purchasers’ products.

No license, express or implied, to any intellectual property right is granted by ST herein.

Resale of ST products with provisions different from the information set forth herein shall void any warranty granted by ST for such product.

ST and the ST logo are trademarks of ST. For additional information about ST trademarks, please refer to www.st.com/trademarks. All other product or service names are the property of their respective owners.

Information in this document supersedes and replaces information previously supplied in any prior versions of this document.

© 2020 STMicroelectronics – All rights reserved