

User Manual

Original Instructions



Allen-Bradley

Guardmaster[®]

Guardmaster Safety Relays

Catalog Numbers 440R-S13R2, 440R-S12R2, 440R-D22R2, 440R-D22S2, 440R-EM4R2, 440R-EM4R2D



Important User Information

Read this document and the documents listed in the additional resources section about installation, configuration, and operation of this equipment before you install, configure, operate, or maintain this product. Users are required to familiarize themselves with installation and wiring instructions in addition to requirements of all applicable codes, laws, and standards.

Activities including installation, adjustments, putting into service, use, assembly, disassembly, and maintenance are required to be carried out by suitably trained personnel in accordance with applicable code of practice.

If this equipment is used in a manner not specified by the manufacturer, the protection provided by the equipment may be impaired.

In no event will Rockwell Automation, Inc. be responsible or liable for indirect or consequential damages resulting from the use or application of this equipment.

The examples and diagrams in this manual are included solely for illustrative purposes. Because of the many variables and requirements associated with any particular installation, Rockwell Automation, Inc. cannot assume responsibility or liability for actual use based on the examples and diagrams.

No patent liability is assumed by Rockwell Automation, Inc. with respect to use of information, circuits, equipment, or software described in this manual.

Reproduction of the contents of this manual, in whole or in part, without written permission of Rockwell Automation, Inc., is prohibited

Throughout this manual, when necessary, we use notes to make you aware of safety considerations.



WARNING: Identifies information about practices or circumstances that can cause an explosion in a hazardous environment, which may lead to personal injury or death, property damage, or economic loss.



ATTENTION: Identifies information about practices or circumstances that can lead to personal injury or death, property damage, or economic loss. Attentions help you identify a hazard, avoid a hazard, and recognize the consequence.

IMPORTANT

Identifies information that is critical for successful application and understanding of the product.

Labels may also be on or inside the equipment to provide specific precautions.



SHOCK HAZARD: Labels may be on or inside the equipment, for example, a drive or motor, to alert people that dangerous voltage may be present.



BURN HAZARD: Labels may be on or inside the equipment, for example, a drive or motor, to alert people that surfaces may reach dangerous temperatures.



ARC FLASH HAZARD: Labels may be on or inside the equipment, for example, a motor control center, to alert people to potential Arc Flash. Arc Flash will cause severe injury or death. Wear proper Personal Protective Equipment (PPE). Follow ALL Regulatory requirements for safe work practices and for Personal Protective Equipment (PPE).

	Preface	
	Summary of Changes	7
	Who Should Use This Manual?	7
	Definitions	7
	Additional Resources	8
	Chapter 1	
Overview	Hardware Features	9
	Removable Terminal Blocks	9
	Status Indicators	9
	Multi-position Switches	10
	Optical Communication Bus	10
	CI Safety Relay (Cat. No. 440R-S13R2)	10
	DI Safety Relay (Cat. No. 440R-D22R2)	10
	DIS Safety Relay (Cat. No. 440R-D22S2)	10
	EM Safety Relay (Cat. No. 440R-EM4R2)	11
	EMD Safety Relay (Cat. No. 440R-EM4R2D)	11
	SI Safety Relay (Cat. No. 440R-S12R2)	11
	Chapter 2	
Installation	Mounting Dimensions	13
	DIN Rail Mounting and Removal	13
	Removal	13
	Spacing	14
	Removable Terminals	14
	Enclosure Considerations	14
	Prevent Excessive Heat	15
	Chapter 3	
Power, Ground, and Wire	Wiring Requirements and Recommendation	17
	Wire Size	17
	Terminal Torque	17
	Terminal Assignments	18
	Ground the Relay	19
	Connect a Power Supply	20
	Safety Inputs	20
	Devices with Mechanical Contacts	20
	Devices with OSSD Output	22
	Safety Mats	23
	Safedge Safety Edges	24
	Safety Outputs	25
	Electromechanical Outputs	26
	OSSD Outputs	26
	Surge Suppressors	27
	Single Wire Safety Input and Output	28
	Auxiliary Output	29

	Reset and Monitor Input	29
	Automatic/Manual Reset	31
	Monitored Reset	31
	Monitor with Expansion Relays.....	32
	Retriggerable Input.....	33
	Jog Input	33
	Chapter 4	
Configuration	Switch Adjustment.....	36
	DI and DIS Safety Relays.....	36
	EMD Safety Relay	37
	Configuration Process	38
	Five Steps to Configure Your GSR Relay	38
	Chapter 5	
Status Indicators	Indicators During Powerup	41
	Indicators During Normal Operation.....	41
	Indicators During Diagnostics.....	42
	Chapter 6	
Pulse Testing Functions	Pulse Testing for Inputs.....	43
	CI Safety Relay	43
	DI, DIS, and SI Safety Relays	44
	Pulse Testing for OSSD Outputs	44
	Chapter 7	
EMD Safety Relay Timing Functions	Off Delay, Non-retriggerable	45
	Case 1	45
	Case 2	46
	Case 3	46
	Off Delay, Retriggerable	46
	Case 1	46
	Case 2	47
	On Delay.....	47
	Case 1	47
	Case 2	47
	Jog.....	48
	Case 1	48
	Case 2	49
	Case 3	49
	Chapter 8	
Internal Circuit Block Diagrams	CI Safety Relay (Cat. No. 440R-S13R2).....	51
	DI Safety Relay (Cat. No. 440R-D22R2).....	51
	DIS Safety Relay (Cat. No. 440R-D22S2).....	51
	EM Safety Relay (Cat. No. 440R-EM4R2)	52
	EMD Safety Relay (Cat. No. 440R-EM4R2D).....	52
	SI Safety Relay (Cat. No. 440R-S12R2)	52

	Chapter 9	
Application and Wiring Examples	CI Safety Relay (Cat. No. 440R-S13R2).....	53
	DI Safety Relay (Cat. No. 440R-D22R2).....	54
	DIS Safety Relay (Cat. No. 440R-D22S2).....	55
	EM Safety Relay (Cat. No. 440R-EM4R2).....	56
	EMD Safety Relay (Cat. No. 440R-EM4R2D).....	57
	SI Safety Relay (Cat. No. 440R-S12R2).....	58
	Chapter 10	
Ethernet Communication	Web Page.....	60
	Studio 5000 Logix Designer Add-on Profile (AOP).....	60
	Chapter 11	
Troubleshooting	Tools Needed.....	61
	Required Tools.....	61
	Optional Tools.....	61
	Follow These Steps.....	62
	View the PWR/Fault Status Indicator (Step 1).....	63
	Check the Power Supply (Step 2).....	65
	Check Voltage.....	65
	Verify Grounding at the Power Supply.....	66
	Check Safety Device Inputs (Step 3).....	66
	Check Voltage-free Contacts.....	67
	Examine Pulse Test Waveforms.....	70
	Effect of OSSD Test Pulses.....	70
	Detect Off Pulses.....	71
	Capacitance Effect.....	71
	Long Wire — Resistance Effect.....	72
	Channel Simultaneity (Discrepancy).....	73
	Multiple-channel Cycling.....	73
	Recovery Time.....	74
	Check the Single Wire Safety Circuit (Step 4).....	74
	SWS Connections L11 and L12.....	74
	Check the Reset/Monitoring Circuit (Step 5).....	76
	Two-handed Reset Operation.....	77
	Applications with OSSD Outputs and Test Pulses.....	77
	Check the Safety Outputs (Step 6).....	78
	Electromechanical Output Issues.....	78
	OSSD Output Issues.....	79
	Auxiliary Output Issues.....	83
	EMD Expansion Relay B1/B2 Inputs (Step 7).....	86
	Terminal Block Removal and Replacement.....	87
	Terminal Block Removal.....	87
	Terminal Block Replacement.....	87
	Series, Version, and Manufacturing Date Code.....	88
	Current Product Label.....	88
	Old Product Label.....	88

Specifications	Appendix A	
	General.....	89
	Environmental.....	89
	Safety Inputs IN, IN1, and IN2.....	90
	Reset Input	90
	B1 Input.....	91
	Safety Outputs.....	91
	Auxiliary Output.....	92
Single Wire Safety.....	92	
Regulatory Approvals	Appendix B	
	Agency Certifications.....	93
	Compliance to European Union Directives.....	93
	EMC Directive.....	93
	Machine Safety Directive.....	93
	SIL Rating	94
Performance Level/Category	94	
	Index95

This manual is a reference guide for the family of Guardmaster® Safety Relays (GSR). It describes the procedures that you use to install, wire, and troubleshoot your relay. This manual also gives an overview of the operation of safety relays.

Summary of Changes

This manual contains new and updated information as indicated in the following table.

Topic	Page
Updated Devices with OSSD Output section	22
Updated Safety Mats section	23
Added Troubleshooting chapter	61

Who Should Use This Manual?

Use this manual if your responsibilities include design, installation, programming, or troubleshooting of control systems that use safety relays, including catalog numbers:

- 440R-S13R2 (CI safety relay)
- 440R-D22R2 (DI safety relay)
- 440R-D22S2 (DIS safety relay)
- 440R-EM4R2 (EM safety relay)
- 440R-EM4R2D (EMD safety relay)
- 440R-S12R2 (SI safety relay)

You must have a basic understanding of electrical circuitry and familiarity with safety-related control systems. If you do not have this knowledge, obtain the proper training before using this product.

Definitions

Publication [AG-7.1](#) contains a glossary of terms and abbreviations that are used by Rockwell Automation to describe industrial automation systems. The following is a list of specific terms and abbreviations that are used in this manual.

- **N.C. (Normally Closed)** - An electrical contact whose normal state is in the closed position.
- **N.O. (Normally Open)** - An electrical contact whose normal state is in the open position.
- **PLC** - A programmable logic controller or a programmable automation controller.
- **Reaction Time** - The time between the true states of one input to the ON state of the output.

- **Recovery Time** - The time that is required for the input to be in the LO state before returning to the HI state.
- **Reset** - Safety relays offer two types of reset: monitored manual and automatic/manual.
 - **Monitored Manual** - The safety relay performs a reset function when the reset signal goes from OFF to ON and then back to OFF in a prescribed time-period. The reset occurs on the trailing edge.
 - **Automatic/Manual** - The safety relay performs a reset function if the reset input is ON. If the reset input is connected directly to 24V, the reset function is executed immediately when the inputs become closed or active. If a contact (push button or equivalent device) is used in the reset input, the reset function is executed on the leading edge of the reset signal (if the inputs are closed or active).
- **Response Time** - Describes the time between the trigger of one input to the OFF state of the output. Throughout this manual, the safety outputs are described as turning off immediately, which means that the safety outputs turn off within the response time.
- **OSSD (Output Signal Switching Device)** - Typically a pair of solid-state signals that are pulled up to the DC source supply. The signals are tested for short circuits to the DC power supply, short circuits to the DC common and shorts circuits between the two signals.
- **Single Wire Safety (SWS)** - A unique, safety-rated signal that is sent over one wire to indicate a safety status. The SWS can be used in safety systems that require Category 4, Performance Level e, per ISO 13849-1 and safety integrity level (SIL) 3, per IEC 62061 and IEC 61508. When an SWS signal is present, this publication describes this state as ACTIVE or ON. This signal is also referred to as the logic link signal.

Additional Resources

These documents contain additional information concerning related products from Rockwell Automation.

Resource	Description
Guardmaster EtherNet/IP™ Network Interface User Manual, publication 440R-UM009	Describes procedures that you use to install, wire, configure, troubleshoot, and use EtherNet/IP modules.
Industrial Automation Wiring and Grounding Guidelines, publication 1770-4.1	Provides general guidelines for installing a Rockwell Automation® industrial system.
Product Certifications website, http://www.rockwellautomation.com/global/certification/overview.page	Provides declarations of conformity, certificates, and other certification details.

You can view or download publications at <http://www.rockwellautomation.com/global/literature-library/overview.page>. To order paper copies of technical documentation, contact your local Allen-Bradley distributor or Rockwell Automation sales representative.

Overview

The Guardmaster safety relay (GSR) family is a group of advanced general-purpose and special-purpose safety relays. This user manual addresses the CI, DI, DIS, EM, EMD, and SI safety relays from this family of relays.

Hardware Features

Figure 1 - Safety Relays

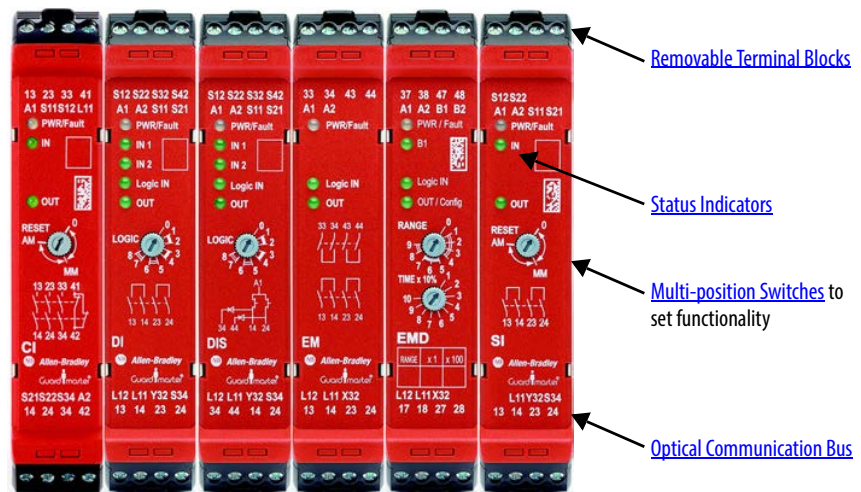

Removable Terminal Blocks

Each relay module is only 22.5 mm (0.9 in.) wide with four removable terminal blocks (two on top and two on bottom). The terminal blocks are keyed to confirm that they are installed in their proper slots. See [Terminal Block Removal and Replacement on page 87](#).

Status Indicators

Multiple status indicators provide status and diagnostics. Under fault conditions, the PWR/Fault status indicator blinks in specific patterns to help diagnose the fault. See [Status Indicators on page 41](#) and [View the PWR/Fault Status Indicator \(Step 1\) on page 63](#) for more information.

Multi-position Switches

Most safety relays are configured by adjusting multi-position switches to set their functionality.⁽¹⁾ The switches are on the front face of the relay so you can see the set position during, and after, configuration. During the configuration process, status indicators on the front face of the relay confirm the switch settings. See [Switch Adjustment on page 36](#) for more information.

Optical Communication Bus

The DI, DIS, EM, EMD, and SI safety relays have an optical communications bus that delivers status and diagnostics to the catalog number 440R-ENETR EtherNet/IP module (not shown in [Figure 1 on page 9](#)) without additional wiring. See [Ethernet Communication on page 59](#) for more information.

Safety relays use single wire safety (SWS) signals that allow multiple safety relays to work in coordination with one another in small to medium size safety systems. The SWS feature allows safety relays to communicate the highest safety-rated control signal from one safety system to another over one wire (plus a common ground connection). The wire must be less than 30 m (98.4 ft) long.

CI Safety Relay (Cat. No. 440R-S13R2)

The CI safety relay has one dual-channel input with three electromechanical relay outputs. The CI safety relay can be configured for automatic or monitored manual reset by adjusting the switch on the front. The CI safety relay has an SWS output, but does not support SWS input.

The CI safety relay is compatible to the MSR127 safety monitoring relay. The CI safety relay has the same number of inputs and outputs, the same width, and the same terminal locations as the MSR127 relay.

DI Safety Relay (Cat. No. 440R-D22R2)

The DI safety relay has two dual-channel inputs and two electromechanical relay outputs. In addition, the DI safety relay has an SWS input and output. The DI safety relay can be set for automatic or monitored manual reset by adjusting the switch on the front panel. The configuration switch also sets the AND/OR logic that is applied to the inputs.

DIS Safety Relay (Cat. No. 440R-D22S2)

The DIS safety relay has two dual-channel inputs and four solid-state outputs. Two of the four solid-state outputs are designed to operate with high-capacitance loads. In addition, the DIS safety relay has an SWS input and output. The DIS safety relay can be set for automatic or monitored manual reset by adjusting the switch on the front panel. The configuration switch also sets the AND/OR logic that is applied to the inputs.

(1) The EM safety relay does not require configuration.

EM Safety Relay (Cat. No. 440R-EM4R2)

The EM safety relay is an expansion module with four immediately operated electromechanical relay outputs. The only input to the EM safety relay is an SWS input. The EM safety relay is designed to expand the outputs of the GSR family of host relays. The EM safety relay also has an SWS output for further expansion.

EMD Safety Relay (Cat. No. 440R-EM4R2D)

The EMD safety relay is an expansion module with delayed electromechanical relay outputs. The EMD safety relay can be configured for one of the following functions:

- On delay
- Off delay
- Jog

The settings of the two switches on the front face of the relay configure the functionality and duration of the delay and jog.

The main input to the EMD safety relay is the single wire safety input. With the SWS signal, the EMD safety relay is designed to expand the outputs of the GSR family of host relays. The EMD safety relay also has an SWS output for further expansion.

An additional input is used with the jog function or to set the off delay as retriggerable. See [EMD Safety Relay Timing Functions on page 45](#) for detailed descriptions on the EMD safety relay timing functions.

SI Safety Relay (Cat. No. 440R-S12R2)

The SI safety relay has one dual-channel input with two electromechanical relay outputs. The SI safety relay can be configured for automatic or monitored manual reset by adjusting the switch on the front. The SI safety relay also has an SWS output.

The SI safety relay is similar in functionality to the MSR126 safety monitoring relay.

Notes:

Installation

All safety relays in this manual have the same dimensions ([Figure 2](#)).

Mounting Dimensions

Figure 2 - Dimensions [mm (in.)]

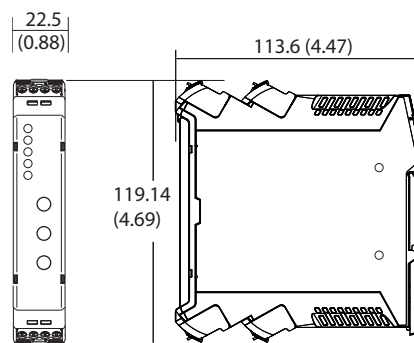

DIN Rail Mounting and Removal

Safety relays mount onto 35 mm DIN rails: 35x7.5x1 mm (EN 50022-35x7.5).

1. Hold the top at an angle ([Figure 3](#)).
2. Slide down until the housing catches the rail.
3. Swing the bottom down and push until the latch clips onto the rail.

Figure 3 - DIN Rail Mounting

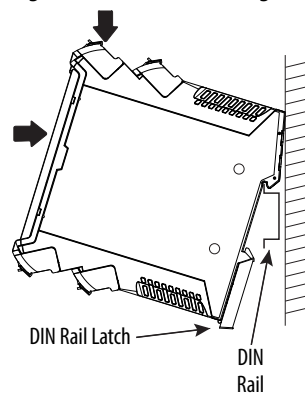

Removal

To remove a safety relay, use a screwdriver to pry the DIN rail latch downwards until it is in the unlatched position. Then, swing the module up.

Spacing

Safety relays can be mounted directly next to other safety relays. When the EtherNet/IP module is used, the safety relay must be mounted within 10 mm (0.4 in.) of its neighboring module to maintain effective communication.

Maintain a space of 50.8 mm (2 in.) above, below, and in front of the relay for adequate ventilation.

Removable Terminals

Safety relays have removable terminals to ease wiring and replacement.

Figure 4 - Removable Terminals

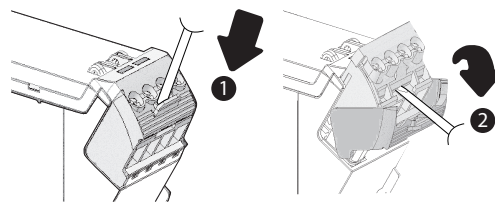

1. Insert the tip of a small screwdriver into the slot near the terminal screws.
2. To unlock the terminal block, rotate the screwdriver.

The terminal block can then be removed from the housing.

Enclosure Considerations

Most applications require installation in an industrial enclosure to reduce the effects of electrical interference and environmental exposure. Pollution Degree 2 is an environment where normally only non-conductive pollution occurs except that occasionally temporary conductivity that is caused by condensation shall be expected. Overvoltage Category II is the load level section of the electrical distribution system. At this level, transient voltages are controlled and do not exceed the impulse voltage capability of the product insulation.

This equipment is intended for use in a Pollution Degree 2 industrial environment, in overvoltage Category II applications (as defined in IEC 60664-1), at altitudes up to 2000 m (6562 ft) without derating. This equipment is considered Group 1, Class A industrial equipment according to IEC/CISPR 11. Without appropriate precautions, there may be difficulties with electromagnetic compatibility in residential and other environments due to conducted and radiated disturbances.

This equipment is supplied as open-type equipment. The relays must be mounted within an enclosure that is suitably designed for those specific environmental conditions that are present and appropriately designed to help prevent personal injury as a result of accessibility to live parts. The enclosure must have suitable flame-retardant properties to help prevent or minimize the spread of flame, in compliance with a flame spread rating of 5VA, V2, V1, V0 (or equivalent) if non-metallic. The interior of the enclosure must be accessible only by the use of a tool. Subsequent sections of this publication contain additional information regarding specific enclosure-type ratings that are required to comply with certain product safety certifications.

For more information, see:

- Industrial Automation Wiring and Grounding Guidelines, publication [1770-4.1](#), for additional installation requirements.
- NEMA Standard 250 and IEC 60529, as applicable, for explanations of the degrees of protection provided by different types of enclosure.

Prevent Excessive Heat

For most applications, normal convective cooling keeps the relay within the specified operating range. Verify that the specified temperature range is maintained. Proper spacing of components within an enclosure is usually sufficient for heat dissipation.

In some applications, other equipment inside or outside the enclosure can produce a substantial amount of heat. In this case, place blower fans inside the enclosure to help with air circulation and to reduce “hot spots” near the controller.

Additional cooling provisions are necessary when high ambient temperatures are encountered. Do not bring in unfiltered outside air. Place the controller in an enclosure to help protect it from a corrosive atmosphere. Harmful contaminants or dirt could cause improper operation or damage to components. In extreme cases, you may need to use air conditioning to help protect against heat buildup within the enclosure.

Notes:

Power, Ground, and Wire

Wiring Requirements and Recommendation



ATTENTION: Before you install and wire any device, disconnect power to the system.



ATTENTION: Calculate the maximum possible current in each power and common wire. Observe all electrical codes that dictate the maximum current allowable for each wire size. Current above the maximum rating causes wiring to overheat, which can cause damage.

- Allow for at least 50 mm (2 in.) between I/O wire ducts or terminal strips and the relay.
- Route incoming power to the relay by a path separate from the device wiring. Where paths must cross, their intersection must be perpendicular.
- Do not run signal or communications wiring and power wiring in the same conduit. Route wires with different signal characteristics by separate paths.
- Separate wiring by signal type. Bundle wiring with similar electrical characteristics together.
- Separate input wiring from output wiring.
- Label wiring to all devices in the system. Use tape, shrink-tubing, or other more dependable means to label wire. Use colored insulation as well to identify wiring by signal characteristics. For example, use blue for DC wiring and red for AC wiring.

Wire Size

Each terminal accommodates copper wire with size from 0.2...2.5 mm² (24...14 AWG). Use copper that withstands 60...75 °C (140...167 °F).

Terminal Torque

Torque terminals to 0.4 N·m (4 lb·in).

Terminal Assignments

Safety relays have four terminals: two on the top and two on the bottom. As shown in [Figure 5](#), the X2 and X4 terminal markings apply to the rear terminals. The X1 and X3 terminals apply to the front terminals.

Figure 5 - Terminal Identification

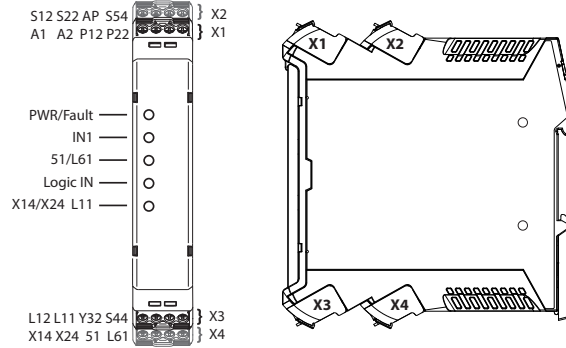

[Figure 6](#) shows the markings on the front face of each safety relay, including the terminal and status indicator identifications.

Figure 6 - Relay Face Markings

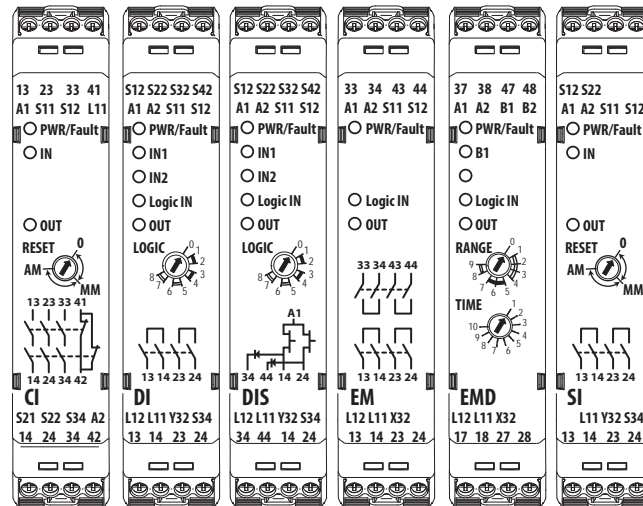

[Table 1](#) lists the terminal functions. Many of the terminals perform common functions on multiple relays.

Table 1 - Terminal Assignments and Functions

Terminal	Function	Applies To
A1	+24V Supply (+10%, -15%)	All
A2	24V Common	All
S11	Pulse Test Output for Channel 1	CI, DI, DIS, and SI
S21	Pulse Test Output for Channel 2	CI, DI, DIS, and SI
S12	Safety Input for IN1 Channel 1	CI, DI, DIS, and SI
S22	Safety Input for IN1 Channel 2	CI, DI, DIS, and SI
S32	Safety Input for IN2 Channel 1	DI and DIS
S34	Reset Input	CI, DI, DIS, and SI
S42	Safety Input for IN2 Channel 2	DI and DIS
Y32	Auxiliary Non-safety Output	CI, DI, DIS, and SI
X32	Auxiliary Non-safety Output	EM and EMD
B1	Jog Input	EMD
B2	Retrigger Input	EMD
L11	Single Wire Safety Output	All
L12	Single Wire Safety Input	DI, DIS, EM, and EMD
13/14, 23/24	Safety Outputs - electromechanical relay	CI, DI, EM, and SI
33/34, 43/44	Safety Outputs - electromechanical relay	EM
14, 24	Safety Outputs - OSSD	DIS
34, 44	Safety Outputs - OSSD for capacitive loads	DIS
17/18, 27/28, 37/38, 47/48	Safety Outputs, Delayed - electromechanical relay	EMD

Ground the Relay

There are no special grounding requirements. Terminal A2 must be connected to the common of a 24V supply.

Connect a Power Supply

An external 24V DC power supply source must provide power for safety relays.

To comply with the CE (European) Low Voltage Directive (LVD), a DC source compliant with safety extra low voltage (SELV) or protected extra low voltage (PELV) must power the safety relays. Bulletin 1606 power supplies are SELV- and PELV-compliant.

[Figure 7](#) shows the power supply connections. The DI, DIS, EM, EMD, and SI safety relays have the power supply connections at the top. The CI safety relay, which is backward compatible with the MSR127 monitoring safety relay, has A1 at the top and A2 at the bottom.

Figure 7 - Power Supply Connections

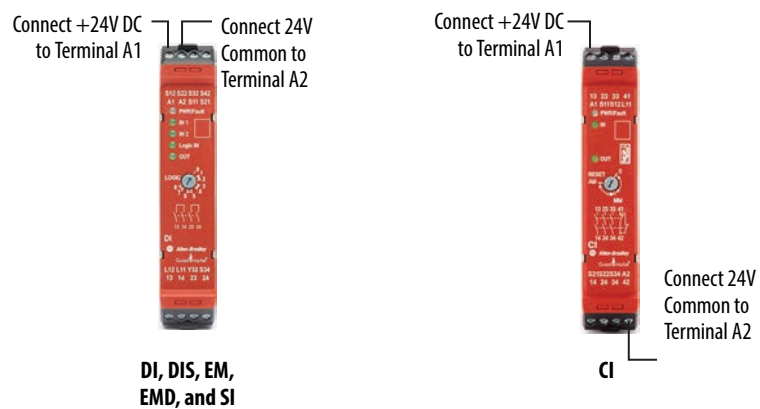

Safety Inputs

GSR relays can be connected to the following devices:

- Devices with mechanical contacts
- Devices with OSSD output
- Safety mats
- Safedge™ safety edges

Devices with Mechanical Contacts

The GSR family of safety relays can be connected to safety devices that have mechanical contacts. The relays can accommodate either 1 N.C. or 2 N.C. circuits. [Table 2 on page 21](#) shows some of the devices that can be connected to safety relays.

Table 2 - Safety Devices with Mechanical Contacts

Safety Device	Rockwell Automation Product Examples	Contact Availability
E-stop push buttons	800F, 800T	1 N.C., 2 N.C., self-monitoring
Tongue-operated interlock switches	Trojan™, MT-GD2, Cadet™, Elf™	1 N.C., 2 N.C.
Guard locking interlock switches	440G-LZ, TLS-Z, TLS-GD2, Atlas™	1 N.C., 2 N.C.
Noncontact switches with reed relays	Ferrogard™, Sipha™, magnetically coded	1 N.C., 2 N.C.
Hinge-operated interlock switches	Rotacam™, Ensign, Sprite	1 N.C., 2 N.C.
Limit switches	440P, 802T	1 N.C., 2 N.C.
Trapped key interlocks with electrical contacts	440T	1 N.C., 2 N.C.
Cable pull switches	Lifeline™	1 N.C., 2 N.C.
Enabling devices	GripSwitch	1 N.C., 2 N.C.
Interposing relays	700-HPS	1 N.C., 2 N.C.

Figure 8 shows the typical connections for devices with 2 N.C. mechanical contacts. One side of each contact is connected to a pulse-testing outputs S11 and S21. The other side is connected to an input terminal. The CI and SI safety relays only have one set of input terminals. The DI and DIS safety relays have two sets of input terminals. The DI and DIS safety relays can operate with only one device that is connected to either input or with devices that are connected to both inputs.

Figure 8 - Example Connections to 2 N.C. Mechanical Contacts

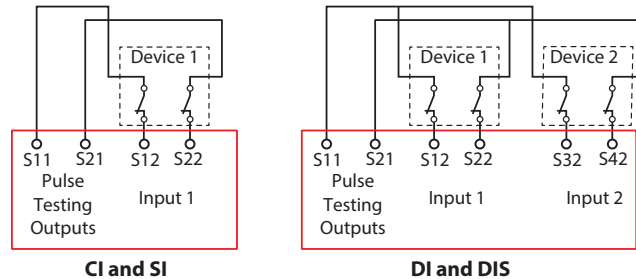
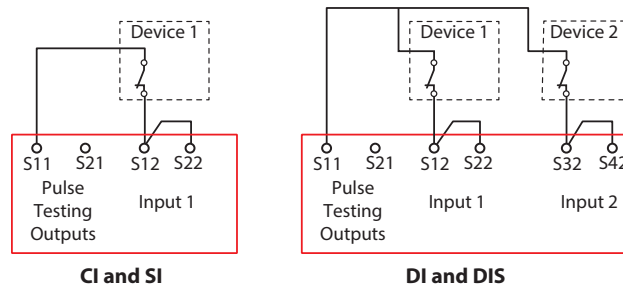

Figure 9 shows the typical connections for devices with 1 N.C. mechanical contact. One side of the contact is connected to a pulse-testing output S11. The other side is connected to two input terminals. The CI and SI safety relays only have one set of input terminals. The DI and DIS safety relays have two sets of input terminals. The DI and DIS safety relays can operate with only one device that is connected or with devices that are connected to both inputs.

Figure 9 - Example Connections to 1 N.C. Mechanical Contact



Devices with OSSD Output

Devices, such as the GuardShield™ safety light curtains, SafeZone™ laser scanners, SensaGuard™ interlock switch, TLS-Z and 440G-LZ guard locking switches, and Bulletin 442G Multifunction Access Box (MAB) have current-sourcing PNP semiconductor outputs (OSSD), which send their own pulse-tested safety signals through their outputs. These devices do not need to be connected to the safety relay pulse-testing outputs. These devices must have a common power supply reference (24V Com).

Figure 10 shows a typical example of the connections for devices, like light curtains or laser scanners, with non-cascadable OSSD outputs.

Figure 10 - Example Connections to Devices with Non-cascadable OSSD Outputs

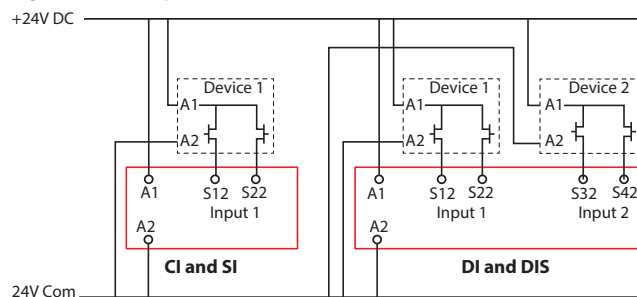

- TIP**
- OSSD1 can be connected to either S12 or S22 and OSSD2 can be connected to either S12 or S22.
 - The safeguarding devices must have the same voltage supply reference (24V Com) as the safety relay.

Figure 11 on page 23 shows an example of a wiring configuration that includes non-cascadable and cascade-able devices. The non-cascadable devices (Devices 1 and 2) must always start the cascade. Many cascadable devices (Devices 3...6 or more) can be included in the input circuit. All devices must have the same voltage supply reference (for instance, 24V Com) as the safety relay.

Examples of non-cascadable devices include GuardShield light curtains, SafeZone laser scanners, and safety sensors. Examples of cascadable devices include SensaGuard interlocks, and the TLS-ZR and 440G-LZ guard locking interlocks.



ATTENTION: You must consider the cumulative response time of all cascaded devices, the relay, and output devices to verify that the safety function is fulfilled within the required time that the risk assessment determines.

Devices with electromechanical (EM) outputs must be placed after the non-cascadable device. The EM devices can be placed anywhere in the chain after the first OSSD device.

From the perspective of the GSR relay, only the OSSD device closest to the relay (Device 3 in [Figure 11](#)) is of concern. The other devices with OSSD outputs do not affect the performance of the safety relay. The EM Devices can suffer from masked faults, their safety rating is limited to Category 3 per ISO13849-1.

Figure 11 - Example Connections to Device with Cascaded and Non-cascaded OSSD Devices

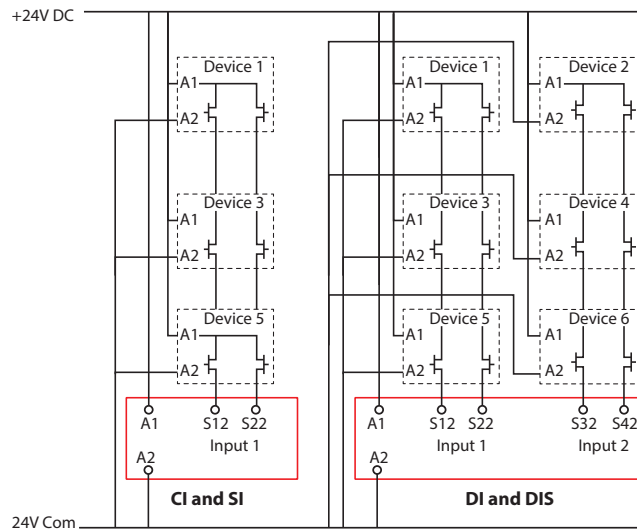

GSR relays cannot detect short circuits of the OSSD device outputs. The PWR/Fault status indicator of your GSR relay remains solid green. The device with the OSSD outputs must detect short circuits of its own OSSD outputs. When detected, the device must shut off both OSSD outputs and go to a faulted state. A status indicator must inform you that the OSSD device is faulted.

Safety Mats

Guardmaster (and similar) safety mats can be connected to safety relays. These mats use parallel metal-plate technology. Stepping on the mat shorts the top metal plate to the bottom metal plate. With the proper connections, safety relays detect the presence of an object on the mat and turn off their outputs. With no presence on the mat, safety relays turn on their outputs.

When changing the function from mechanical switches or OSSDs to safety mats, GSR relays must go through the complete configuration process.

[Figure 12 on page 24](#) shows the typical connections for safety mats. You notice the reverse of the wiring between a device with 2 N.C. contacts and the safety mat.

When a safety mat is used, safety relays cannot detect short circuits between the inputs or between the inputs and 24V DC. These conditions must be tested during validation.

IMPORTANT For fault detection purposes, GSR relays must be configured for monitored manual reset when connected to Safedge safety edges.

IMPORTANT When using safety mats, the DI and DIS safety relays must be set for AND logic. If only one mat is used, the second input must be connected with jumpers or to another safety device. If another safety device is connected to the second input, the outputs of the safety device must be ON during configuration and during powerup.

Figure 12 - Example Connections to Safety Mats

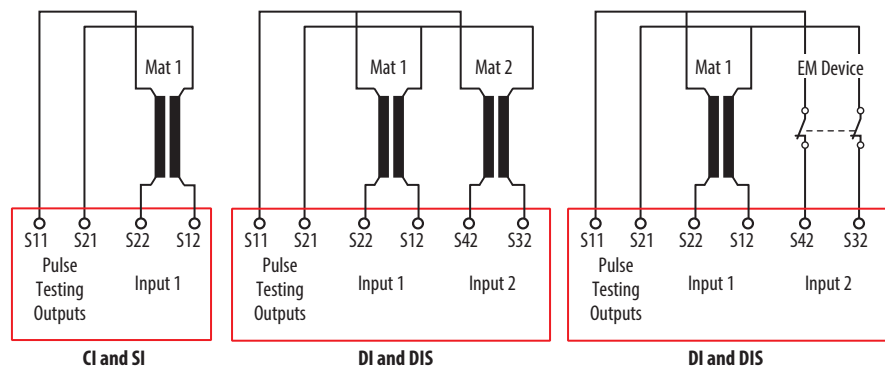

Because the safety mats are parallel plates, they have a significant capacitive effect. The larger the mat, the more capacitance. If the capacitance is too large, the safety relay does not function properly. See [Capacitance Effect on page 71](#) for further information.

TIP Older Allen-Bradley Guardmaster MSR relays could be tickled by tapping on the safety mat, which generated fast cycles. This activity caused the relay to fault because the fast cycles violated the recovery time specification. GSR relays have a 20 ms recovery time, so this fault is not likely to occur.

Safedge Safety Edges

The Allen-Bradley Guardmaster Safedge pressure sensitive safety edges can be connected to CI, DI, DIS, and SI safety relays. [Figure 13](#) shows how Safedge edges are constructed of conductive rubber with two embedded wires that run the length the edge. Each wire forms a channel for the GSR safety relay. When the edge is compressed, a low resistance is created between the two channels. The Safedge edge must be constructed with four wires (two wires exit each end). See publication [440F-UM002](#) for further information on the Safedge edges.

Figure 13 - Safedge Operating Principle

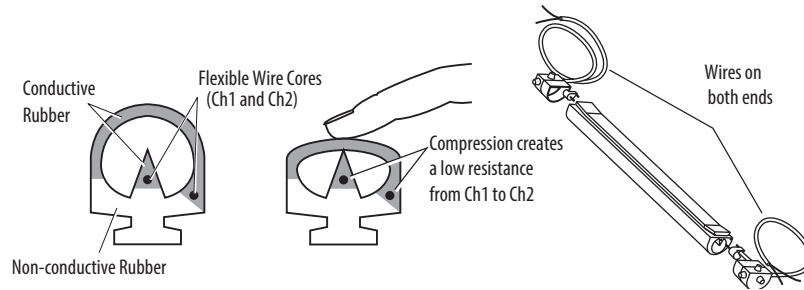
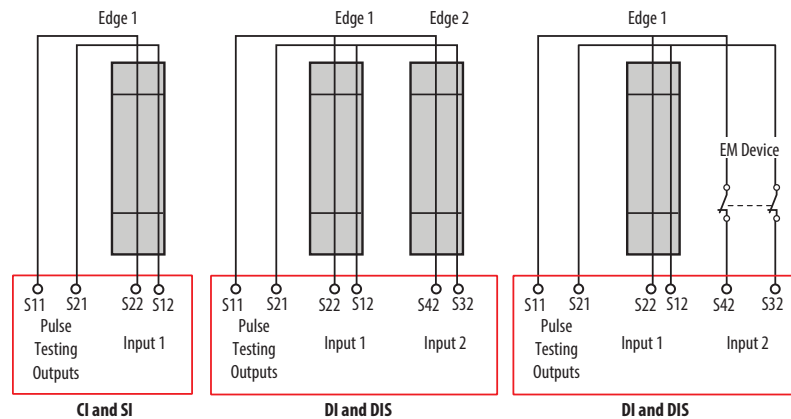

Figure 14 shows the typical wire connections. With the proper connection, GSR relays detect the compression of the edge and turn off their outputs. With no pressure on the edge, the GSR outputs can be turned back on with a reset signal.

IMPORTANT For fault detection purposes, GSR relays must be configured for monitored manual reset when connected to Safedge safety edges.

IMPORTANT When using safety edges, the DI and DIS safety relays must be set for AND logic. If only one edge is used, the second input must either be connected with jumpers or to another safety device. If another safety device is connected to the second input, the outputs of the safety device must be ON during configuration and during powerup.

Figure 14 - Example Connections to Safety Edges



Safety Outputs

GSR relays have two types of outputs:

- Electromechanical (CI, DI, EM, EMD, and SI safety relays)
- OSSD (DIS safety relay)

To extend the operating life of the safety relays surge suppression is required.

Electromechanical Outputs

Internally, the CI, DI, EM, EMD, and SI safety relays have two positive-guided relays that are connected in series to form the safety outputs. One side of the contact must be connected to a voltage supply (see [Specifications on page 89](#) for appropriate ratings). The other side of the contact must be connected to a load.

Figure 15 - Electromechanical Output Connections

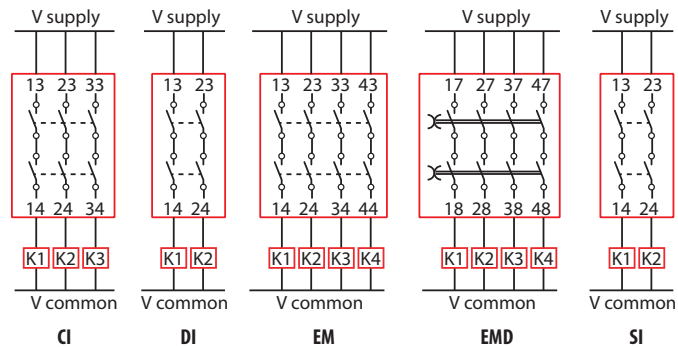

OSSD Outputs

The DIS safety relay has OSSD safety outputs on terminals 14, 24, 34 and 44. Output terminals 14 and 24 are pulse tested and can switch loads up to 1.5 A. They can only tolerate a load capacitance up to 1.6 μF . Terminals 34 and 44 have a series diode and can switch loads up to 0.5 A. They can tolerate a load capacitance up to 9 μF . Terminals 34 and 44 are also pulse tested, but these pulse tests are ignored as they are not used for short-circuit detection. These terminals are intended for devices with high capacitance. For example, use terminals 34 and 44 when connecting to the Enable input of the PowerFlex[®] 70 drive and the Safe Torque Off inputs of the PowerFlex and Kinetix[®] drives.

The pulse-tested outputs check for short circuits between the following:

- Each terminal.
- Each terminal and the 24V supply.
- Each terminal and 24V common. The load must be connected to the same voltage reference as terminal A2.

The load must be connected to the same voltage reference as terminal A2. All four OSSD outputs are short-circuit protected.

Figure 16 - OSSD Output Connections

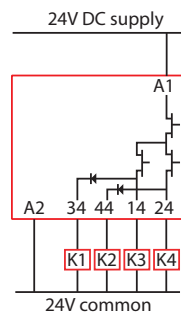

Surge Suppressors

Because of the potentially high current surges that occur when switching inductive load devices, such as motor starters and solenoids, the use of surge suppression to help protect and extend the operating life of the relays is required. By adding a suppression device directly across the coil of an inductive device, you prolong the life of the outputs. You also reduce the effects of voltage transients and electrical noise from radiating into adjacent systems.

[Figure 17](#) shows an output with a suppression device. We recommend that you locate the suppression device as close as possible to the load device.

For outputs that use 24V DC, we recommend 1N4001 (50V reverse voltage) to 1N4007(1000V reverse voltage) diodes for surge suppression for the OSSD safety outputs ([Figure 17](#)). The diode must be connected as close as possible to the load coil.

For outputs that use 120V AC or 240V AC, we recommend metal oxide varistors.

Figure 17 - Surge Suppressors

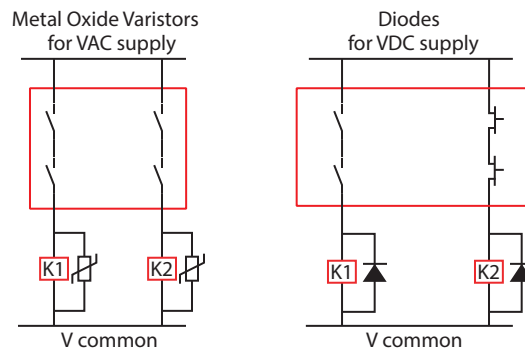

Example surge suppressors include the following catalog numbers:

- 100-FSD250 for Bulletin 100S contactors
- 1492-LD4DF terminal block with built-in 1N4007 diode
- 1492-JD3SS terminal block with built-in varistor

Single Wire Safety Input and Output

The Single Wire Safety (SWS) feature allows a safety relay to expand the safety function to additional safety relays using one wire, provided all safety relays have the same voltage supply reference.

The CI and SI safety relays only have SWS outputs (terminal L11). The DI, DIS, EM, and EMD safety relays have both SWS inputs (terminal L12) and SWS outputs (terminal L11).

There can be many variations and combinations of series and parallel connections of the SWS. Each L11 terminal can be connected to up to ten L12 terminals.

IMPORTANT Do not connect two or more L11 terminals together.

Figure 18 shows an example wiring diagram with SWS input from a DI safety relay and SWS output connection to an EM safety relay in parallel with a DIS safety relay. The safety relays must have a common power reference (24V common). In this example, the safety function started by the CI or SI safety relay is expanded to the DI safety relay. The safety functions monitored by the DI safety relay are expanded to the EM and DIS safety relays. The safety functions monitored by the DIS safety relay are expanded to the EMD safety relay.



ATTENTION: You must consider the additional response time of each SWS connection when calculating the safety distance. See [Specifications on page 89](#) for the response time for each relay.

Figure 18 - Example SWS Connections

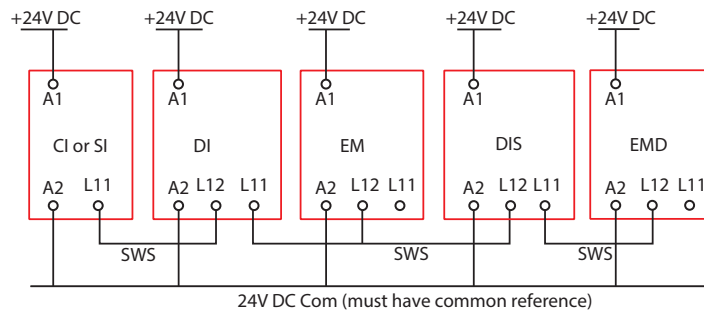

Figure 19 shows the characteristics of SWS signal when it is active. It starts with a 1 ms pulse, followed 700 μ s later by a 500 μ s pulse. This waveform is repeated every 4 ms. When inactive, the SWS is 0V.

Figure 19 - SWS Waveform



Auxiliary Output

Each safety relay has an auxiliary output. The auxiliary output is not a safety rated output; it is a low current output that is designed to indicate that the safety output status is OFF. The auxiliary output is in the opposite state of the safety outputs. When the safety outputs are ON, the auxiliary output is OFF. When the safety outputs are OFF, the auxiliary output is ON.

When the EM and EMD safety relays are in a faulted state, the auxiliary outputs are in an OFF state because the auxiliary outputs are often used as the source of the monitoring circuit. If the EM or EMD safety relays are faulted, the safety system must not reset until the fault is corrected.

The DI, DIS, EM, EMD, and SI safety relays have a solid-state transistor auxiliary output. The CI safety relay has an electromechanical output. [Table 3](#) summarizes the terminal connections of the auxiliary output.

Table 3 - Auxiliary Outputs

Relay	Type of Output	Terminal Connections
CI	Electromechanical	41/42
DI, DIS, SI	Transistor	Y32
EM, EMD	Transistor	X32

Reset and Monitor Input

The CI, DI, DIS, and SI safety relays have a reset/monitoring input (terminal S34). The expansion relays (EM and EMD) do not have a reset input.

The reset action can be configured for either automatic or manual reset. When the relay is configured for automatic reset, the safety relay outputs turn ON as soon as the safety inputs are closed if terminal 34 is connected to 24V. If a normally open switch is placed in the circuit, the reset function occurs on the leading edge (when the switch is pressed).

When the relay is configured for manual reset, the safety relay outputs turn ON after the inputs are closed and then the reset input is cycled from OFF to ON and then back OFF again.

Monitoring of external devices, like safety control relays and safety contactors, can be accomplished by adding normally closed contacts in series with the reset signal. [Figure 20 on page 30](#) shows typical reset/monitoring circuits.

Figure 20 - Typical Reset/Monitoring Circuits

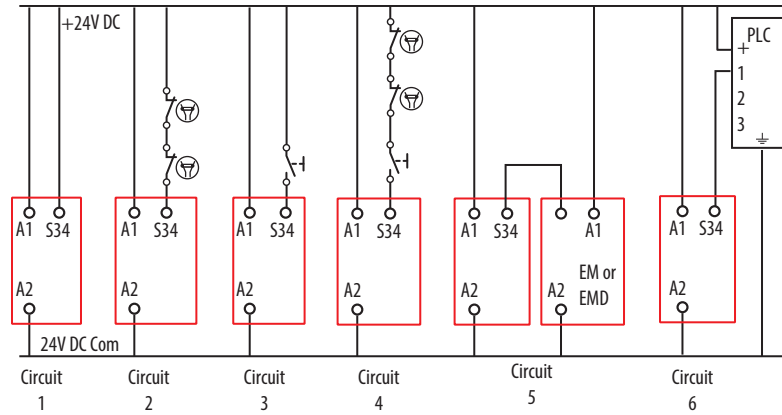

Circuit	Description
1	In automatic/manual reset, a direct connection can be made to 24V DC.
2	Output devices are monitored with their normally closed contacts. This circuit can only be used in automatic/manual reset.
3	A normally open push button is used. The relay can be configured for automatic/manual reset or monitored manual reset.
4	Output devices are monitored along with a normally open push button. The relay can be configured for automatic/manual reset or monitored manual reset.
5	An EM or EMD expansion relay is used to supply the voltage to terminal S34. This circuit can also contain feedback contacts and a reset push button, similar to circuits 2, 3, and 4.
6	A PLC is used to generate the reset signal. The GSR relay can be configured for either automatic/manual or monitored manual reset.

Automatic/Manual Reset

Use automatic reset when the risk assessment does not require additional manual intervention to reset the safety system. Automatic reset is often used with partial body access or where an additional control is implemented in the machine control system to start the hazardous portion of the machine after the safety inputs are closed.

When automatic reset is desired, the S34 input must be connected to 24V DC. [Figure 21 on page 31](#) shows three possibilities:

- A direct connection
- A connection through some monitoring contacts
- A connection through a normally open push button.

Connection through a monitoring contact and push button can be combined. When a push button is used, the reset occurs when the circuit is closed (not when it is released).

Figure 21 - Automatic/Manual Reset Connections

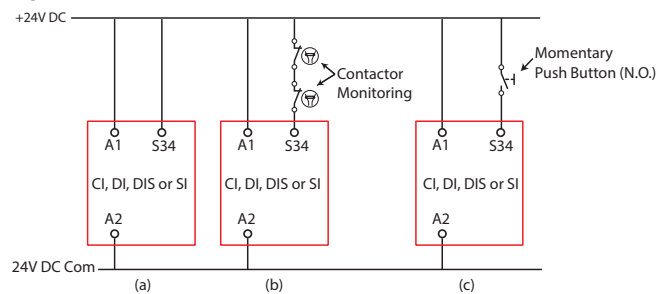

Monitored Reset

Monitored reset requires a specific signal to turn on the safety outputs. The safety inputs and single wire safety input (if used) must be closed before the reset. The reset signal must cycle from 0V to 24V and back to 0V within a duration of 250...3000 ms, as shown in [Figure 22](#). The reset occurs on the trailing edge. If the reset signal is too short or too long, the reset function is not executed and can be tried again.

Monitored reset must be used in applications that have full-body access to the hazard. Monitored reset can also be used in applications that require partial body access.

Figure 22 - Monitored Reset Signal Duration

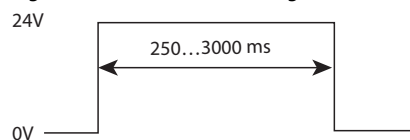

The signal can be created with a momentary push button or programmatically created with logic controller. [Figure 23](#) shows example wire connections for the reset. The schematic also shows an example monitoring the mechanically linked, normally closed contacts of two contactors.

TIP When using a PLC to generate the reset signal, set the duration to 260...2990 ms for a more reliable reset.

Figure 23 - Monitored Reset Connections

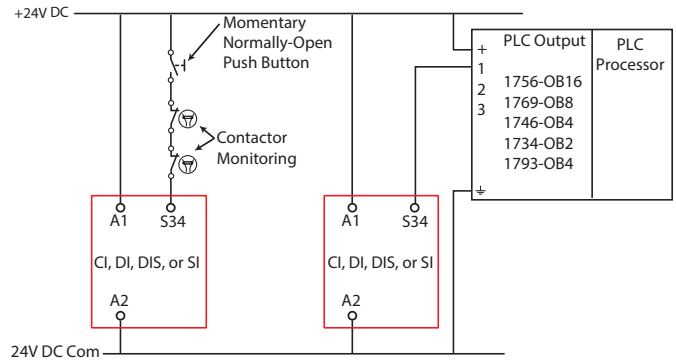

Monitor with Expansion Relays

Monitoring of the expansion relays is recommended. This feature is especially useful when the expansion relay is turning on loads (for example, solenoid-operated valves) that do not have monitoring contacts. The auxiliary output of the expansion relay must be the 24V DC source of the reset and monitoring input. [Figure 24](#) shows an example of the connections for a monitored reset with additional contactor monitoring. This type of connection can also be used for automatic reset applications.

Figure 24 - Monitor Expansion Relay

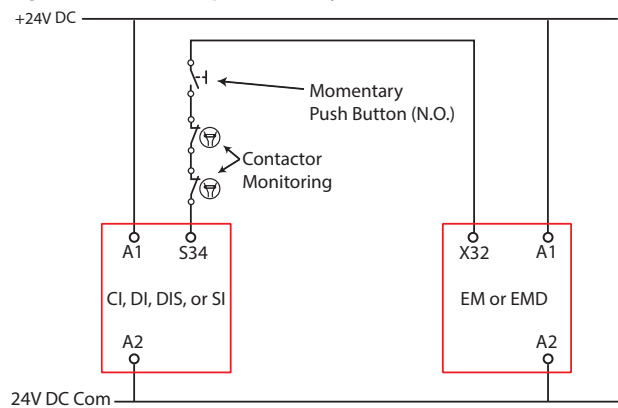

Retriggerable Input

The B1 and B2 inputs determine the type of timing function.

- **B1 and B2 open:** Off-delay non-retriggerable or on-delay
- **B1 connected to B2:** Off-delay retriggerable
- **B1 connected to 24V DC:** Jog

The EMD safety relay has a retriggerable input. Retriggerable operation only works in off-delay applications. Retriggerable operation is accomplished by connecting a jumper from terminal B1 to B2. [Table 4](#) describes the off-delay operation.

Table 4 - Retriggerable Operation

Configuration	Jumper	Action
Retriggerable	B1-B2	If the safety input is triggered and cleared within the duration of the time delay, then the timing request is ignored and the safety output contacts remain closed. The B1 indicator is ON.
Non-retriggerable	None	The full time delay lapses and the safety output contacts open before the relay can be reset. The B1 indicator is OFF.

Jog Input

When the EMD safety relay is configured for the Jog functions, terminal B1 must be connected to +24V DC.

Notes:

Configuration

The multi-position, rotary switches on the front face of a GSR relay determine its functionality. The configuration method of a GSR relay must provide means to help protect against manipulation and maintain integrity of the configuration.

The rotary switches accommodate a small screwdriver to turn the switch to the desired switch position. The configuration procedure implies a willing action by the person that configures the safety function, to prove that the person is conscious and enabled to perform this task. Therefore, GSR relays require a procedure of turning a switch to position “0” to start the configuration mode and then turn to the position desired.

The status indicators on the front panel provide continuous feedback by flashing the switch positions. Power cycling the device in a timely manner completes the configuration mode and the device enters operation.

IMPORTANT To keep your GSR relay from permanently faulting, complete the configuration process by power cycling the relay within 5 minutes after configuring rotary switches.

We recommend that the configuration is completed within 5 minutes. The actual technical limitation of the internal EEPROM is around 8 hours. The switch positions are monitored and verified during configuration by the internal micro-controllers to achieve the required diagnostics coverage for the PLe safety rating. The EEPROM read/write cycles are limited and can cause a permanent fault of the GSR relay after several hours.

Switch Adjustment

These safety relays have multi-position switches on their front face. Use a small screwdriver to set the switches to the desired setting.

TIP Make note of the mechanical stop location.

Figure 25 - Configuration Switch Adjustment

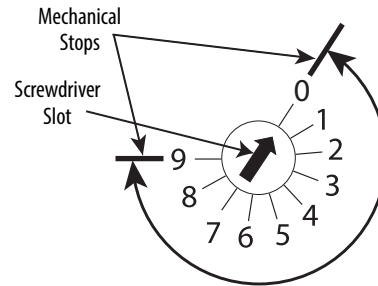

IMPORTANT Adjust the switches gently and do not turn past the mechanical stops.

CI and SI safety relays have a three-position Reset switch. This switch determines whether the relay uses a monitored manual reset or an automatic/manual switch (see [Definitions on page 7](#)).

Table 5 - CI and SI Logic Switch

Position	Function
0	Start configuration
MM	Monitored manual reset
AM	Automatic/manual reset

DI and DIS Safety Relays

The DI and DIS safety relays have a 10-position switch and use only the first nine positions. As shown in [Table 6](#), this switch configures the relay for its reset and logic functionality.

Table 6 - DI and DIS Logic Switch

Position	Reset	Function
0	Not applicable	Start configuration
1	Monitored Manual	(IN1 OR IN2) OR L12
2		(IN1 AND IN2) OR L12
3		(IN1 OR IN2) AND L12
4		(IN1 AND IN2) AND L12
5	Automatic/Manual	(IN1 OR IN2) OR L12
6		(IN1 AND IN2) OR L12
7		(IN1 OR IN2) AND L12
8		(IN1 AND IN2) AND L12

Example 1: Logic setting 1 or 5: If any of the inputs (IN1, IN2, or L12) are ON, then the safety relay refers to the reset logic.

Example 2: Logic setting 4 or 8: If all three of the inputs (IN1, IN2, and L12) are ON, then the safety relay refers to the reset logic.

EMD Safety Relay

The EMD safety relay has two switches. The combination of the switch settings determines the functionality and the duration. During configuration, the Time switch determines the duration of the Range switch. [Figure 26](#) and [Table 7](#) show the setting options for the Range and Time switch.

With the Time switch set to 1 at the start of the configuration process, the duration of the Range switch is the shorter range.

With the Time switch set to 10 at the start of the configuration process, the duration of the Range switch is the longer range.

Figure 26 - EMD Range and Time

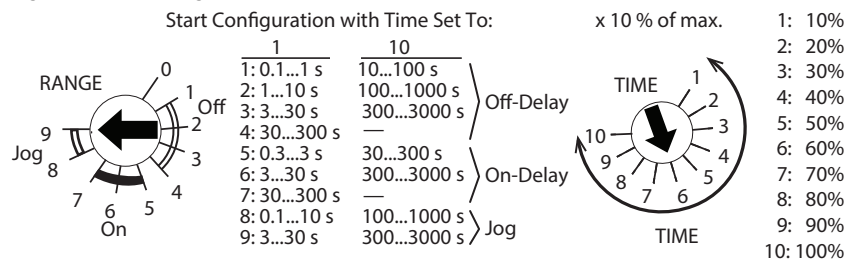

Table 7 - EMD Range and Time Settings

Position	Range			Time
	Function	Range (Time 1) [s]	Range (Time 10) [s]	
0	Start Configuration	—	—	—
1	Off Delay	0.1...1	10...100	10
2		1...10	100...1000	20
3		3...30	300...3000	30
4		30...300	—	40
5	On Delay	0.3...3	30...300	50
6		3...30	300...3000	60
7		30...300	—	70
8	Jogging	0.1...10	100...1000	80
9		3...30	300...3000	90
10	—	—	—	100

Example 1: The range setting is 3 (starting with the Time set to 1), and the Time setting is 5. Then the off-delay is: 30s * 50% = 15 seconds

Example 2: The range setting is 6 (starting with the Time set to 10), and the Time setting is 1. Then the on-delay is: 3,000 s * 10% = 300 seconds

Configuration Process

Configuration is a five-step process. The process requires the wiring to be completed and the inputs closed. During the configuration process, GSR relays send out test pulses to determine how it is wired and then configures the internal parameters to match the application.

Five Steps to Configure Your GSR Relay

1. With the power OFF, prepare the switches.

Safety Relay	Action
DI/DIS	Set the Logic switch to position 0.
CI/SI	Set the Reset switch to position 0
EMD expansion relay	Set the Range switch to position 0 and set Time switch to 1 (short timing range) or 10 (long timing range).
EM expansion relay	No switches. No action necessary.

2. Apply power.

After a short wait, the PWR/Fault status indicator flashes red continuously at a 1 Hz rate (0.5 s ON, 0.5 s OFF). The prior configuration in the EEPROM is erased, and the device is now prepared for a new configuration.

3. Adjust the Logic, Reset, Time, and Range switch settings as needed for your application.

TIP You can change (or readjust) the switch settings during Steps 3 and 4. The power status indicator momentarily flashes red again.

4. Verify the settings by counting the blink rates of the status indicators.

[Table 8](#) shows the indicator that flashes for the corresponding switch setting for each relay.

Table 8 - Configuration Confirmation

Safety Relay	Status Indicator	Switch Setting
CI	IN	Reset
DI	IN 1	Logic
DIS	IN 1	Logic
EMD	B1	Range
	Logic IN	Time
SI	IN	Reset

[Figure 27](#) shows an example of the blinking patterns for the EMD expansion relay. The indicators flash for 0.5 seconds to indicate the switch settings. The number of flashes is equal to the switch setting. The blinking pattern repeats after a 2 second pause.

Figure 27 - EMD Expansion Relay Status Indicators Flashing in Configuration Mode

B1 - Indicates that the RANGE Switch is set to 3.

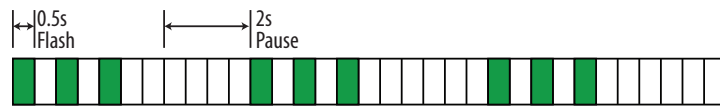

Logic IN - Indicates that the TIME Switch is set to 4



5. Cycle the power to store the settings.

After power-up, the current switch settings are compared to the values in the EEPROM (makes sure that the switches were not changed while power was off), and the input and output circuits are checked. Upon successful completion of the internal checks, the relays are ready for operation.

IMPORTANT To keep your GSR relay from permanently faulting, complete the configuration process by cycling the relay power within 5 minutes of rotary switch configuration.

Notes:

Status Indicators

Indicators During Powerup

The status indicators provide operating status and diagnostic information.

Indicators During Normal Operation

Table 9 - Status Indicators (Normal Operation)

Status Indicator	Models	State	Description
PWR/Fault	All	Solid green	Normal operation.
		Flashing red	Non-recoverable fault. See Table 11 on page 64 . Correct fault and cycle power
		Green with flashing red	Recoverable fault. See Table 12 on page 65 . Correct fault and press Reset.
		Solid red	Internal Fault. Cycle power.
IN or IN 1	CI, DI, DIS, SI	ON	Input circuits at S12 and S22 are closed.
		OFF	Input circuits at S12 and S22 are open.
IN 2	DI, DIS	ON	Input circuits at S32 and S42 are closed.
		OFF	Input circuits at S32 and S42 are open.
B1	EMD	ON	Input circuit at B1 is closed.
		OFF	Input circuit at B1 is open.
LOGIC IN	DI, DIS, EM, EMD	ON	Logic IN signal (Single Wire Safety) at L12 is ON.
		OFF	Logic IN signal at L12 is OFF.
	EMD	Flashing	Timing cycle is in process.
OUT	All	ON	L11 is ON.
		OFF	L11 is OFF.
	CI	ON	13/14, 23/24, 33/34 closed (41/42 open).
		OFF	13/14, 23/24, 33/34 open (41/42 closed).
		Flashing	Safety input is closed, waiting for the reset input.
	DI	ON	13/14, 23/24 closed (Y32 OFF).
		OFF	13/14, 23/24 open (Y32 ON).
		Flashing	Safety inputs are closed, waiting for the reset input.
	DIS	ON	14, 24, 34, 44 ON (Y32 OFF).
		OFF	14, 24, 34, 44 OF (Y32 ON).
		Flashing	Safety inputs are closed, waiting for the reset input.
	EM	ON	13/14, 23/24, 33/34, 43/44 closed (X32 OFF).
		OFF	13/14, 23/24, 33/34, 43/44 open (X32 ON).
	EMD	ON	17/18, 27/28, 37/38, 47/48 closed (X32 OFF).
		OFF	17/18, 27/28, 37/38, 47/48 open (X32 ON).
	SI	ON	13/14, 23/24 closed (Y32 OFF).
		OFF	13/14, 23/24 open (Y32 ON).
		Flashing	Safety input is closed, waiting for reset input.

Indicators During Diagnostics

See the following tables:

Table	Page
PWR/Fault Status Indicator Is Solid Red	63
PWR/Fault Status Indicator Is Flashing Red	64
PWR/Fault Status Indicator Is Green with Flashing Red	65

Pulse Testing Functions

Safety relays use pulse testing of inputs and outputs to verify that the safety function is performed when called upon. Pulse testing for the inputs must be used with devices with mechanical contacts like E-stop push buttons, tongue operated interlock switches, and limit switches. The pulse testing cannot be turned on or off and cannot be changed.

The test pulses are used to detect three short circuit conditions:

- Between the input terminals and +24V.
- Between the input terminals and 24V common.
- Between the two input terminals.

Pulse Testing for Inputs

Pulse testing for the inputs is generated on terminals S11 and S21 of the CI, DI, DIS, and SI safety relays. The EM and EMD safety relays do not use pulse testing.

CI Safety Relay

The pulse testing that is associated with the CI safety relay is shown in [Figure 28](#). The pulse widths are 2.5 ms wide. The pulse testing on S11 and S21 is offset by 1 ms. The pulses are repeated every 14 ms.

Figure 28 - Pulse Test Sequence for CI Safety Relay

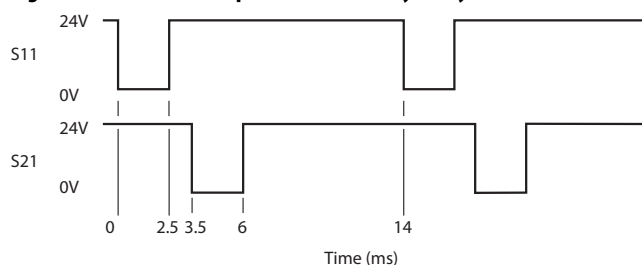

TIP When using a digital multimeter, S11 measures approximately 19V and S21 measures approximately 19V when the supply voltage to A1 is 24V DC and the input circuits are open.

At the minimum-rated input ON voltage (11V), a DC multimeter reads approximately 8.9V DC at S12 and S22.

DI, DIS, and SI Safety Relays

The pulse test sequence for the DI, DIS, and SI safety relays are shown in [Figure 29](#). The sequence is repeated every 13.6 ms.

Figure 29 - Pulse Test Sequence for DI, DIS, and SI Safety Relays

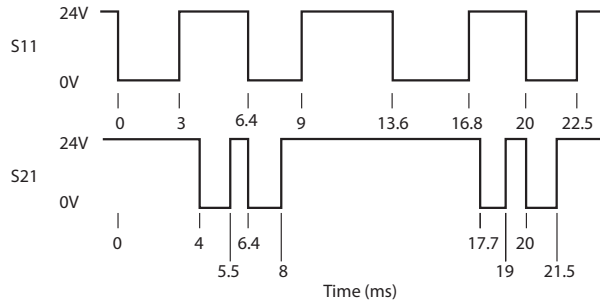

TIP When using a digital voltmeter, S11 measures approximately 14V DC and S21 measures approximately 18V DC when the supply voltage to A1 is 24V DC and the input circuits are open.

Pulse Testing for OSSD Outputs

The DIS safety relay has OSSD transistor outputs. One main transistor supplies current to four individual transistors ([Figure 30](#)). When the main transistor is pulse tested, the pulse appears on all outputs. When the individual transistors are tested, the pulse only appears on that transistor.

Figure 30 - Output Transistor Arrangement

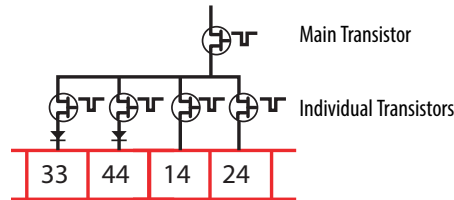

The pulse test pattern is shown in [Figure 31](#). The pulse widths vary from 50...150 μ s. The pulse pattern on terminal 14 is identical to terminal 34, and the pulse pattern on 24 is identical to 44. The pattern is repeated every 3.371 seconds.

Figure 31 - OSSD Output Test Pulses on DIS Safety Relay

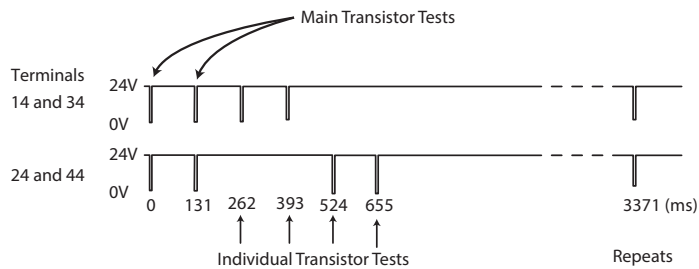

Although pulse tests appear on terminals 34 and 44, the DIS safety relay does not detect faults from A1 to 34, 44 or between 34 and 44 when the outputs are ON.

EMD Safety Relay Timing Functions

The EMD safety relay has three functions that use timing:

- Off delay
- On delay
- Jog

The off-delay timing depends on whether the function is retriggerable.

During the timing cycle, the Logic IN status indicator flashes.

Off Delay, Non-retriggerable

With input B1 open, the off-delay function is not retriggerable. The off-delay timer starts when the logic link signal at terminal L12 turns off. Once started, the off-delay timer runs for its full duration. [Figure 32](#) shows three cases of the timing sequences that can occur with this configuration.

Figure 32 - Off-delay, Non-retriggerable Timing Diagram

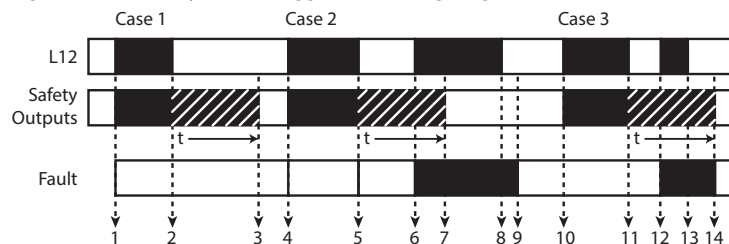

Case 1

1. The logic link signal at terminal L12 turns on and the safety outputs turn on immediately (that is, within the specified reaction time).
2. The logic link signal turns off and the off-delay timer starts.
3. The off-delay time has elapsed, and the safety outputs turn off.

Case 2

4. The logic link signal at terminal L12 turns on, and the safety outputs turn on within the specified reaction time.
5. The logic link signal turns off and the off-delay timer starts.
6. During off-delay time, the logic link signal turns off. A recoverable fault occurs. The PWR/Fault indicator is green and flashing red four times.
7. The off-delay time has elapsed, and the safety outputs turn off.
8. The logic link signal turns off.
9. Shortly after the logic link turns off, the fault is automatically cleared. The PWR/Fault indicator is solid green.

Case 3

10. The logic link signal at terminal L12 turns on, and the safety outputs turn on within the specified reaction time.
11. The logic link signal turns off and the off-delay timer starts.
12. During off-delay time, the logic link signal turns off. A recoverable fault occurs. The PWR/Fault indicator is green and flashing red four times.
13. The logic link turns back off. The fault continues to exist.
14. The off-delay time has elapsed; the safety outputs turn off; and the fault is automatically cleared.

Off Delay, Retriggerable

To use the retriggerable off-delay function, input terminal B1 must be connected to terminal B2 before the configuration process. The off-delay timer starts when the logic link signal at terminal L12 turns off. During the timing cycle, the off-delay timer is automatically reset to zero when the logic link turns back on. [Figure 33](#) shows two cases of the timing sequences that can occur with this configuration.

Figure 33 - Off-delay, Retriggerable Timing Diagram

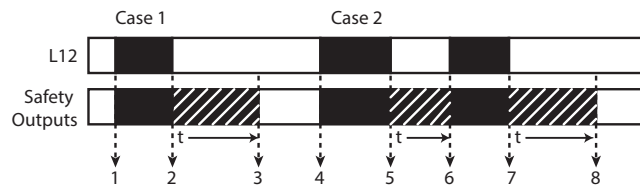

Case 1

1. The logic link signal at terminal L12 turns on, and the safety outputs turn on immediately (that is, within the specified reaction time).
2. The logic link signal turns off, and the off-delay timer starts.
3. The off-delay time has elapsed, and the safety outputs turn off.

Case 2

4. The logic link signal at terminal L12 turns on, and the safety outputs turn on within the specified reaction time.
5. The logic link signal turns off, and the off-delay timer starts.
6. During off-delay time, the logic link signal turns on. The off-delay timer is set back to zero, and the safety outputs remain on. No fault occurs.
7. The logic link signal turns off, and the off-delay timer starts.
8. The off-delay time has elapsed, and the safety outputs turn off.

On Delay

To use the on-delay function, terminal B1 must be an open connection. The on-delay timer starts when the logic link signal at terminal L12 turns on. The safety outputs turn on after the delay time expires and remain on until the logic link signal turns off. If the logic link signal turns off during the timing cycle, the safety outputs turn off immediately. [Figure 34](#) shows two cases of the timing sequences that can occur with this configuration.

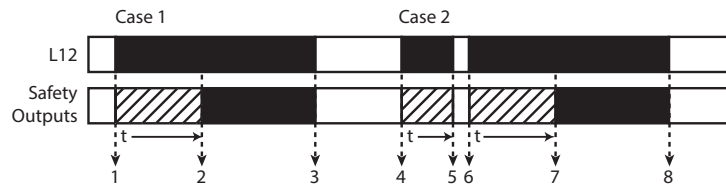
Figure 34 - On-delay Timing Diagram**Case 1**

1. The logic link signal at terminal L12 turns on, and the on-delay timer starts.
2. The on-delay timer elapses, and the safety outputs turn on.
3. When the logic link signal turns off, the safety outputs turn off.

Case 2

4. The logic link signal at terminal L12 turns on, and the on-delay timer starts.
5. The logic link signal turns off before the on-delay time elapses. The on-delay timer is reset to zero. No fault occurs.
6. After a brief interruption (even as short as 100 ms), the logic link signal turns back on. The on-delay timer starts from zero.
7. The on-delay timer elapses, and the safety outputs turn on.
8. When the logic link signal turns off, the safety outputs turn off.

Jog

The jog function has two timers: an on-timer and an off-timer. The Range and Time switch settings set the on-timer during configuration. The on-timer starts when both the B1 terminal is connected to 24V DC and the logic link signal at terminal L12 is on. The order in which these two signals turn on is not relevant. When both signals are on, the safety outputs turn on during the on-timer. After the on-timer expires, the safety outputs turn off and the off-timer starts. The off-timer is fixed at 500 ms. After the safety outputs turn off, they will remain off until the off-timer elapses. Then the jog can be restarted.

[Figure 35](#) shows three cases of timing sequences.

During the on-timer cycle, the Logic IN indicator flashes at a 1 Hz rate. During the off-timer cycle, the Logic IN indicator flashes at an 8 Hz rate.

Figure 35 - Jog Timing Diagram

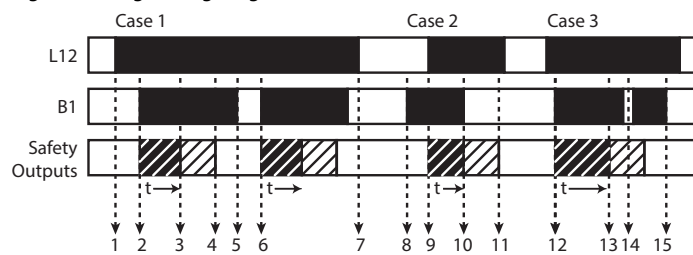

Case 1

1. The logic link signal at terminal L12 turns on.
2. The B1 terminal turns on. The jog on-timer starts, and the safety outputs turn on.
3. The jog on-timer elapses, and the safety outputs turn off. The jog off-timer starts.
4. After 500 ms, the jog function is complete.
5. The B1 inputs turn off.
6. With the logic link input still on, the jog function is repeated when the B1 signal turns on.
7. The logic link signal turns off.

TIP The L12 and B1 signals are interchangeable. The B1 signal can remain on and the L12 turns on and off to execute the jog function.

Case 2

8. The B1 signal turns on before the logic link signal.
9. The logic link signal turns on. The jog on-timer starts, and the safety outputs turn on.
10. The B1 signal turns off before on-timer elapses. The safety outputs turn off immediately and the off-timer starts.
11. The off-timer elapses. The logic link signal turns off to end Case 2.

TIP The L12 and B1 signals are interchangeable. If the B1 signal remains on and the L12 turns off before the on-timer elapses, the safety outputs turn off immediately.

Case 3

12. The logic link signal at terminal L12 is on. The B1 signal turns on. The jog on-timer starts, and the safety outputs turn on.
13. The on-timer elapses and the safety outputs turn off. The off-timer starts.
14. During the off-timer cycle, the B1 signal is turned off and then quickly back on. The safety outputs remain off.
15. The B1 signal must turn off before a new jog cycle can begin.

TIP The L12 and B1 signals are interchangeable. At least one of these two signals must remain off throughout the off-timer cycle before a new jog cycle begins.

Notes:

Internal Circuit Block Diagrams

The figures in this chapter show the internal circuit block diagrams of each safety relay.

CI Safety Relay (Cat. No. 440R-S13R2)

Figure 36 - CI Safety Relay Circuit Diagram

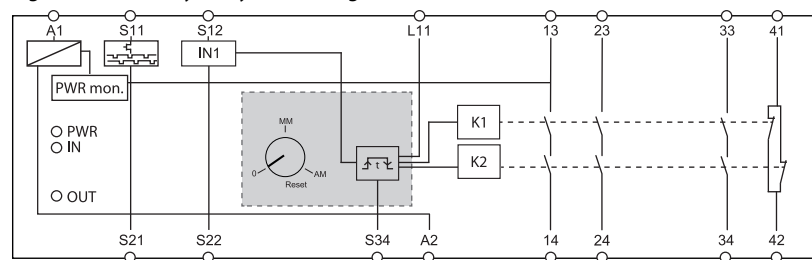

DI Safety Relay (Cat. No. 440R-D22R2)

Figure 37 - DI Safety Relay Circuit Diagram

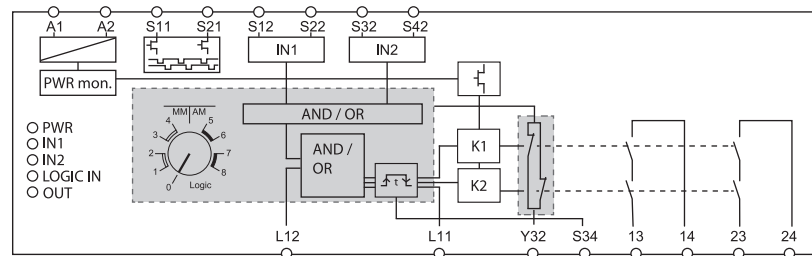

DIS Safety Relay (Cat. No. 440R-D22S2)

Figure 38 - DIS Safety Relay Circuit Diagram

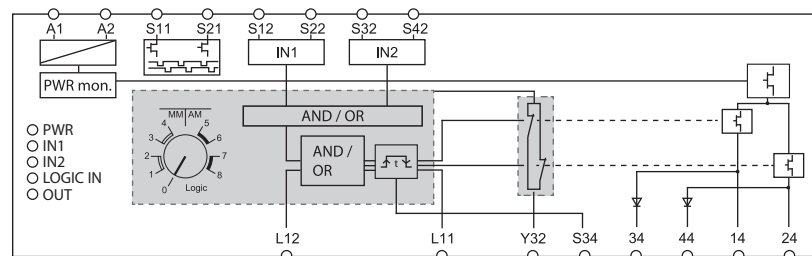

EM Safety Relay (Cat. No. 440R-EM4R2)

Figure 39 - EM Safety Relay Circuit Diagram

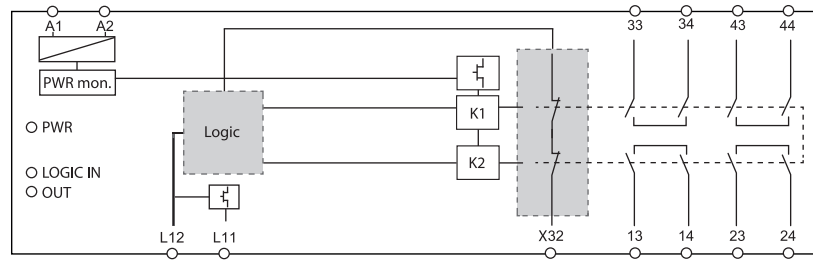

EMD Safety Relay (Cat. No. 440R-EM4R2D)

Figure 40 - EMD Safety Relay Circuit Diagram

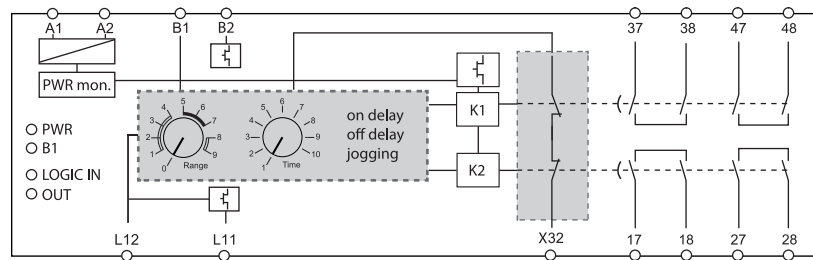

SI Safety Relay (Cat. No. 440R-S12R2)

Figure 41 - SI Safety Relay Circuit Diagram

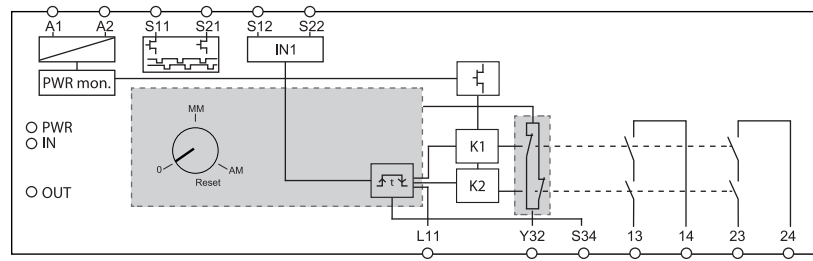

Application and Wiring Examples

The application and wiring examples in this chapter show you how to put the inputs and outputs together to create an operating safety system. These circuit diagrams are examples; many features are interchangeable between relays.

Publication [SAFETY-WD001](#) provides additional application and wiring diagrams.

CI Safety Relay (Cat. No. 440R-S13R2)

In [Figure 42](#), the CI safety relay is monitoring a device (an E-stop push button) with mechanically operated contacts. The CI safety relay is configured for monitored manual (MM) reset. The output turns on if the E-stop is released and the reset push button is pressed and released between 0.25...3 seconds. The CI safety relay monitors the status of the two output contactors, K1 and K2. If either fails to close their N.C. contacts, the CI safety relay does not reset. An auxiliary signal, terminals 41/42, is sent to the PLC when the E-stop is pressed.

Figure 42 - Mechanical Contacts with Monitored Manual Reset

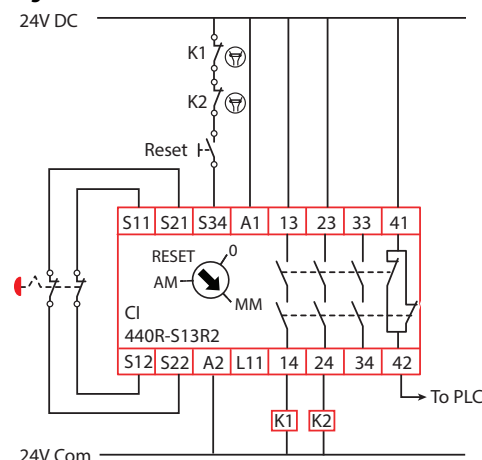
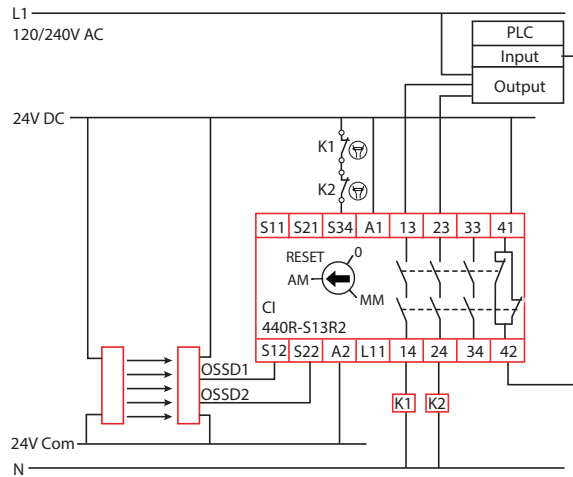

Figure 43 shows a CI safety relay monitoring a light curtain with two OSSD outputs. The CI safety relay is set to automatic/manual reset (AM). The auxiliary signal (terminals 41/41) informs the PLC that the safety system is OFF or ON. The CI outputs connect to AC voltage loads. When the CI safety relay is ON, the PLC can then turn on the K1 and K2 contactors.

Figure 43 - With Device Using OSSD Outputs, Automatic Reset, AC Load Voltage



DI Safety Relay (Cat. No. 440R-D22R2)

The DI safety relay in Figure 44 monitors two devices having mechanical contacts and is set for monitored manual reset. With the two devices closed, the operator presses the reset button to energize contactors K1 and K2. The DI safety relay verifies that contactors K1 and K2 are off by monitoring the mechanically linked normally closed contacts in the reset circuit. When the DI safety relay is off, the auxiliary signal at terminal Y32 turns on and reports the status to a PLC.

Figure 44 - With Two Devices with Mechanical Contacts and Monitored Manual Reset

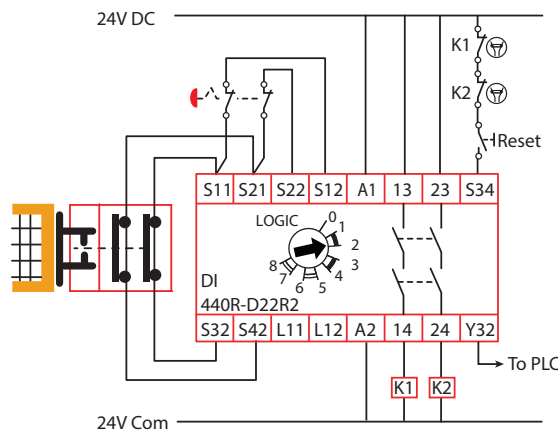

In [Figure 45](#), a DI safety relay monitors a safety mat and non-contact interlock with OSSD outputs. Make note of the specific wiring for the mat. Also, during configuration and for each power-up, the mat must be clear and the interlock closed. The DI safety relay must be configured for AND logic for the two inputs. The DI safety relay logic setting is 6: (IN1 AND IN2) OR L12 with automatic reset. The DI safety relay verifies that contactors K1 and K2 are off by monitoring the mechanically linked normally closed contacts in the S34 circuit. When the DI safety relay is off, the auxiliary signal at terminal Y32 turns on and reports the status to a PLC. Per ISO 13856-1, safety mat applications require a manual reset function. For fault detection purposes, all GSR relays used for safety mat control must be configured for monitored manual reset.

Figure 45 - With a Safety Mat and Device with OSSD Outputs, Monitored Manual Reset, AC Loads

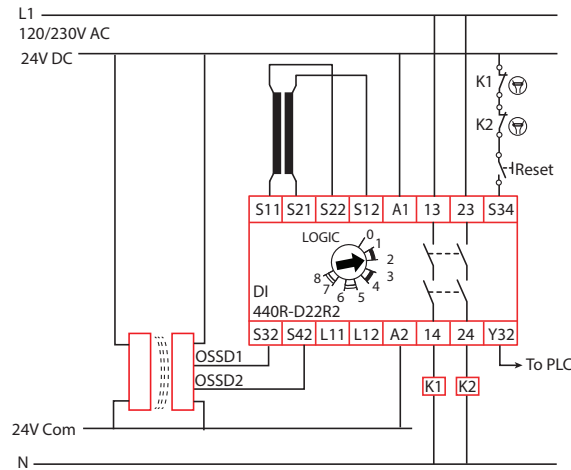

DIS Safety Relay (Cat. No. 440R-D22S2)

[Figure 46](#) shows the DIS safety relay with only one device. The DIS and DI safety relay can monitor one device by configuring the relay for OR logic. The DIS safety relay logic setting is 1: (IN1 OR IN2) OR L12 with monitored manual reset. The second input (terminals S32 and S42) requires no connection. With solid-state outputs, the contactors K1 and K2 must be 24V DC powered coils. The DIS safety relay verifies that contactors K1 and K2 are off by monitoring the mechanically linked normally closed contacts in the S34 circuit. When the DIS safety relay is off, the auxiliary signal at terminal Y32 turns on and reports the status to a PLC.

Figure 46 - Single Input, Monitored Reset

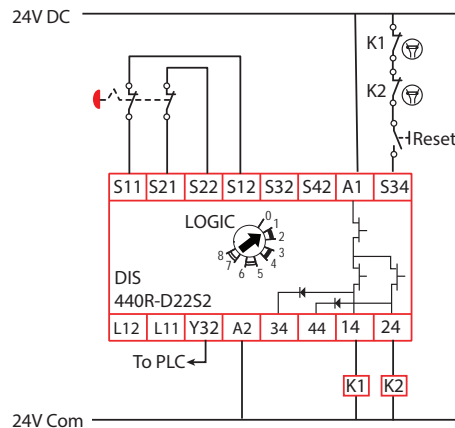

The DIS safety relay monitors two devices with OSSD outputs in [Figure 47](#). The DIS safety relay logic setting is 6: (IN1 AND IN2) OR L12 with automatic reset. The output terminals 34 and 44 are designed to tolerate higher capacitance loads (but lower resistive load) as compared to terminals 14 and 24.

Figure 47 - High Capacitive Load

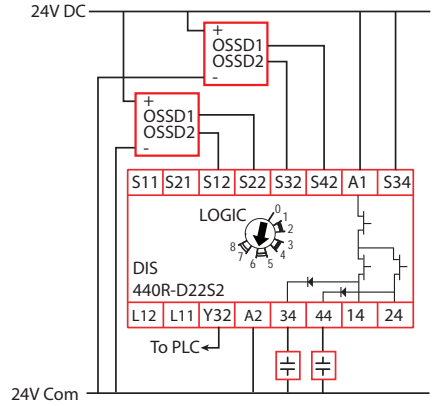

EM Safety Relay (Cat. No. 440R-EM4R2)

The EM safety relay in [Figure 48](#) expands the number of outputs of the DI safety relay. The single wire safety signal from terminal L11 to L12 instructs the EM safety relay to turn on and off. The EM safety relay outputs mimic the DI safety relay outputs. The DI safety relay monitors contactors K1...K6 and the status of the EM safety relay by sourcing the reset signal from the X32 terminal on the EM safety relay.

Figure 48 - Expansion of Immediate Safety Outputs

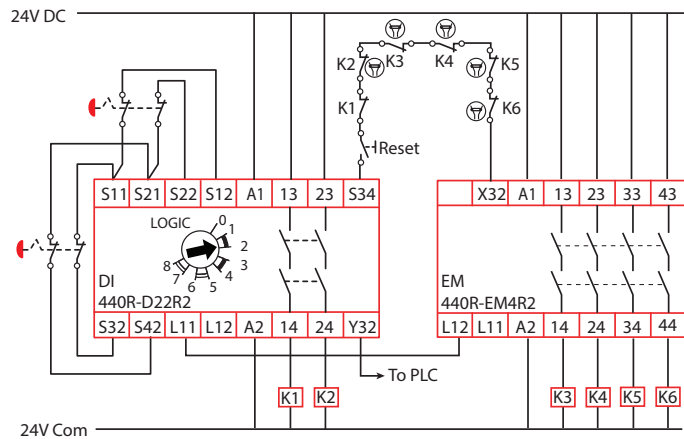

EMD Safety Relay (Cat. No. 440R-EM4R2D)

The EMD safety relay in [Figure 49](#) is configured for a 5 second off-delay. The single wire safety signal from terminals L11 to L12 instructs the EMD safety relay to turn on and off. When the E-stop is pressed, the CI safety relay turns off immediately and the EMD safety relay turns off 5 seconds later. The CI safety relay monitors contactors K1...K6 and the status of the EMD safety relay by sourcing the reset signal from the X32 terminal on the EMD safety relay.

In this example, the jumper from B1 to B2 makes the EMD safety relay retriggerable. If the E-stop is released and the reset is pressed within the 5 second delay time, the outputs of the EMD safety relay do not turn off because the internal timer is retriggered.

Figure 49 - EMD - Off Delay

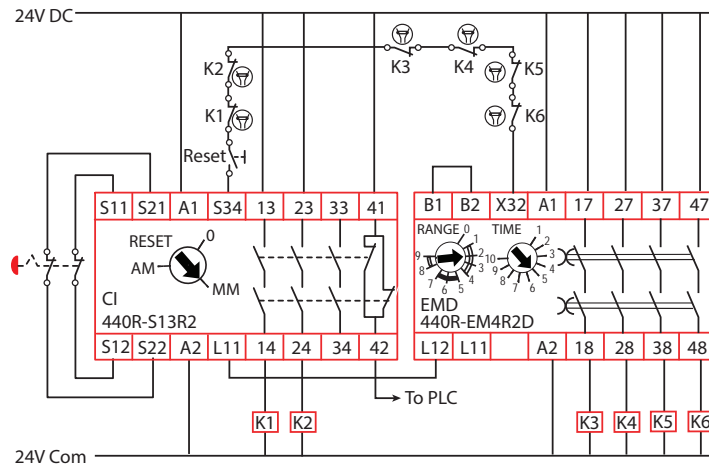

[Figure 50](#) shows the EMD safety relay that is configured for a 2.1 second on-delay. The single wire safety signal from terminals L11 to L12 instructs the EMD safety relay to turn on and off. When the reset button is pressed, the DIS safety relay outputs turn on immediately. After a 2.1 second delay, the EMD safety relay outputs turn on.

The DIS safety relay monitors contactors K1...K4 and the status of the EMD safety relay by sourcing the reset signal from the X32 terminal on the EMD safety relay.

Figure 50 - EMD - On Delay

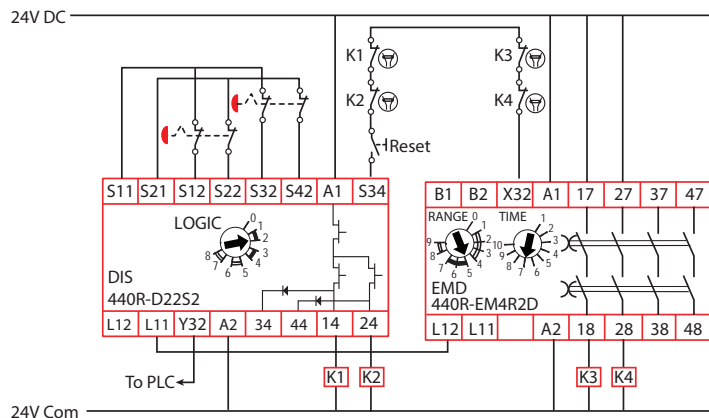

The EMD safety relay in [Figure 51](#) is configured for a maximum of a 100-second jog. The single wire safety signal from terminals L11 to L12 enables the EMD safety relay. When enabled, the jog switch can be pressed and held closed to turn on the EMD safety relay outputs. If the jog button is released before the 100 second time, the EMD safety relay outputs turn off. If the jog button is held longer than 100 seconds, the EMD safety relay outputs only turn on for 100 seconds.

Figure 51 - EMD - Jog

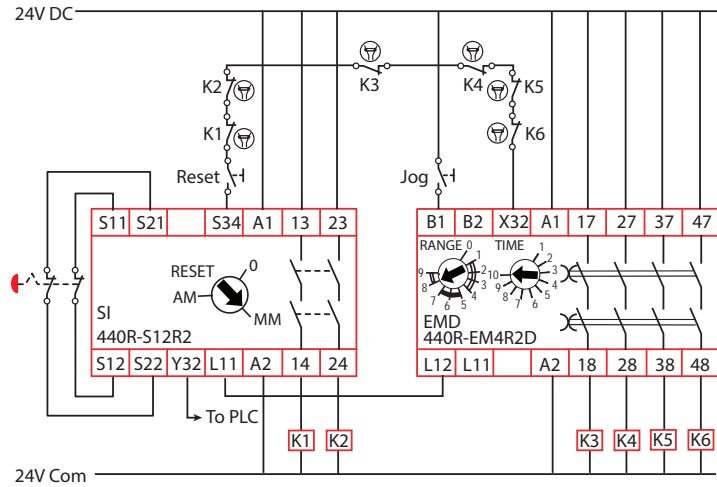

SI Safety Relay (Cat. No. 440R-S12R2)

The SI safety relay monitors a gate interlock with mechanical contacts in [Figure 52](#). The SI safety relay is configured for automatic reset. When the gate is closed, the SI safety relay outputs turn on if contactors K1 and K2 are already off. The Start button can then be pressed to turn on contactors K1 and K2.

Figure 52 - SI Example

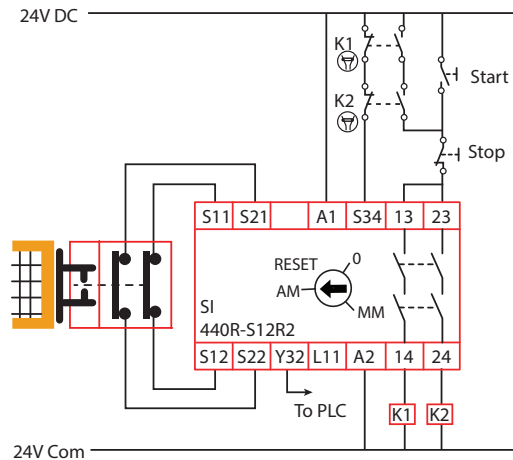

Ethernet Communication

The DI, DIS, EM, EMD, and SI safety relays are equipped with optical communication via an optical link. With an optical link, diagnostic data can be read from these relays and transferred to other devices over EtherNet/IP with the catalog number 440R-ENETR EtherNet/IP module. The CI safety relay does not have an optical link.

The catalog number 440R-ENETR EtherNet/IP module must be in the left-most position ([Figure 53](#)). See publication [440R-UM009](#) for further details on the EtherNet/IP module. The safety relays must be Series A 200 or later.

Figure 53 - Arrangement of EtherNet/IP Module and Safety Relays

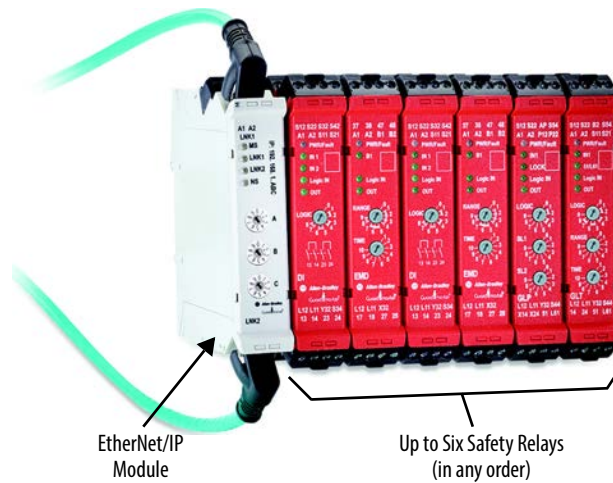

Web Page

The catalog number 440R-ENETR EtherNet/IP module maintains its own web page (Figure 54). To access the web page, connect an Ethernet cable to your computer, open a web browser, and type in the IP address of the ENETR module.

Figure 54 - ENETR Web Page

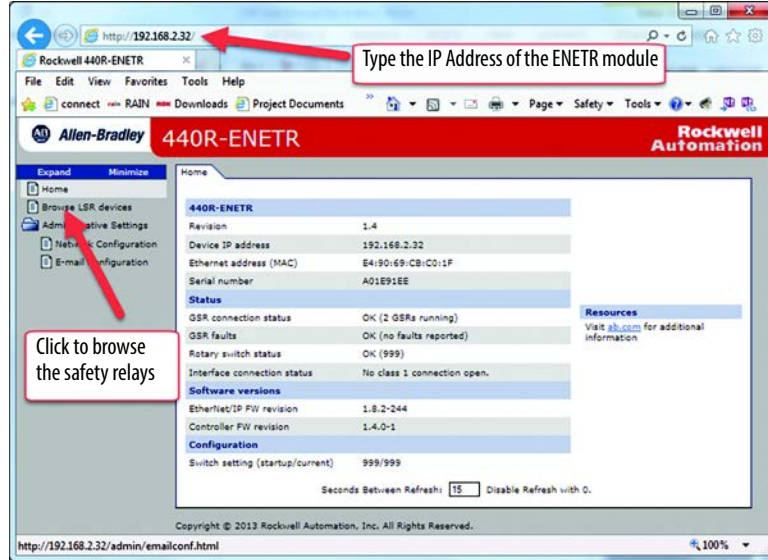

Studio 5000 Logix Designer Add-on Profile (AOP)

The catalog number 440R-ENETR EtherNet/IP module includes the Studio 5000 Logix Designer® AOP for the DI, DIS, EM, EMD, and SI safety relays. The AOP allows you to view the status of the relays, including open and closed inputs, outputs ON and OFF, waiting for reset, and fault information. Figure 55 shows an example of the AOP for the DI safety relay.

See publication [440R-UM009](#) for further details on the EtherNet/IP module.

Figure 55 - AOP for the DI Safety Relay

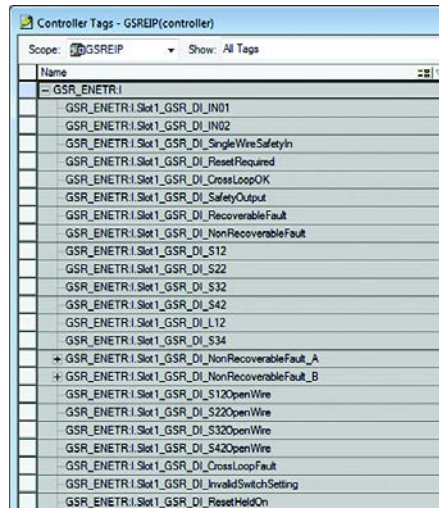

Troubleshooting

This chapter explains a systematic approach to determine the likely cause of the GSR safety relay being in a faulted state or not operating properly. It describes the procedures that you use to troubleshoot your relay.

Tools Needed

To troubleshoot your GSR relay, you need the following tools.

Required Tools

- **Medium-sized Screwdriver:** For terminal screws, to remove terminal blocks, and to configure the switches on the front face of the relays.

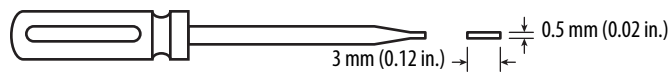

- **Digital Multimeter:** To measure signal levels and contact resistance.

Optional Tools

- **Oscilloscope:** Dual- or four-channel storage scope to view input and output signals and to capture noise transients.
- **Metal Paper Clips:** To insert into the terminals and allow connection of scope probes to terminals.

Follow These Steps

To diagnose the condition of the GSR relay, follow the steps in [Figure 56](#).

Figure 56 - Troubleshooting Flowchart

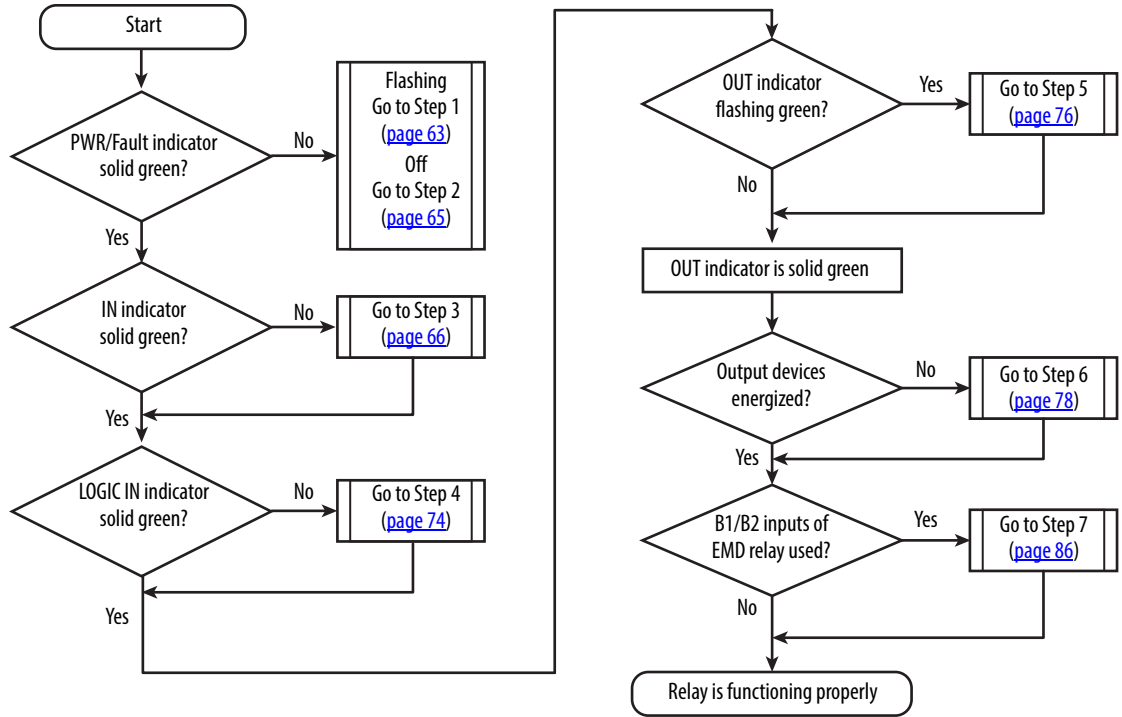

View the PWR/Fault Status Indicator (Step 1)

The first troubleshooting step is to examine the PWR/Fault status indicator on the front of your GSR module. See [Figure 57](#) for status indicator location.

TIP The PWR/Fault status indicator is located in the same position on all GSR modules.

Figure 57 - PWR/Fault Status Indicator

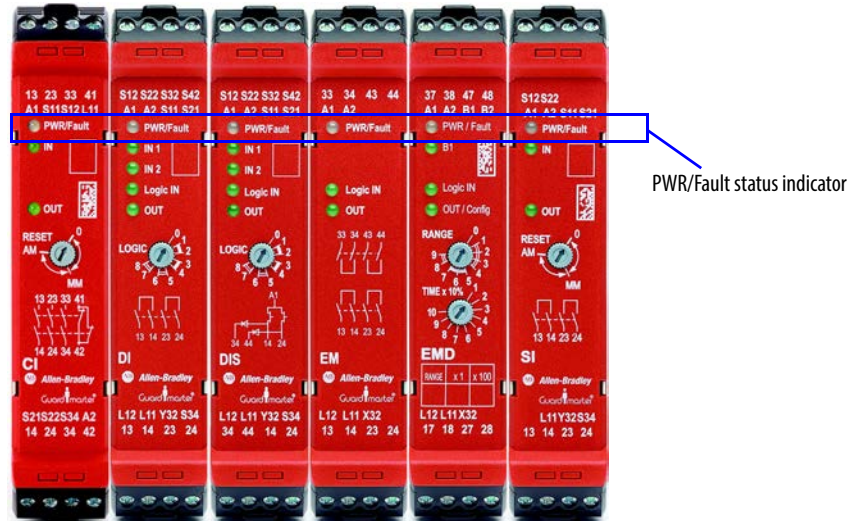

The PWR/Fault status indicator has five possible states:

Status	Description	Action
Off	No power to the relay.	Apply power.
Solid green	The relay is in the run state.	None.
Solid red	The relay is in a non-recoverable faulted state.	See Table 10 on page 63 .
Flashing red	A non-recoverable faulted state	See Table 11 on page 64 .
Green and flashing red	A recoverable faulted state.	See Table 12 on page 65 .

IMPORTANT For accurate diagnostics, always start counting the flashing after the first pause. The first cycle can be inaccurate.

Table 10 - PWR/Fault Status Indicator Is Solid Red

Indicator	Description	Model	Possible Causes	Corrective Action
Solid red	Faults that are not described in Table 11 and Table 12 result in a solid red indicator.	All	<ul style="list-style-type: none"> A momentary power interruption. Noise on the power or signal wires. 	<ul style="list-style-type: none"> Cycle power to clear the fault and return the GSR safety relay to an operational state. Reconfigure the safety relay (see Configuration on page 35). See additional information in Verify Grounding at the Power Supply on page 66.
		CI, DI, DIS, and SI	Short circuit has occurred, or is present, from +24V DC (A1) to S11 or S21 or from 24V Common (A2) to S11 or S21.	
		DIS	Short circuit has occurred, or is present, from +24V DC (A1) to 14 or 24.	
		SI	Excessive capacitance from input wiring to ground, but not enough to cause flashing red four times.	

Table 11 - PWR/Fault Status Indicator Is Flashing Red

Indicator	Description	Model	Possible Causes	Corrective Action
Flashing red 1 time	The GSR relay is in configuration mode.	All	<ul style="list-style-type: none"> The relay is shipped from the factory with no configuration. The configuration process was not completed successfully. 	Continue with the configuration process. Rotate the switches to the desired positions and cycle power.
Flashing red 2 times	Invalid configuration.	All	<ul style="list-style-type: none"> Upon power-up, one or more of the rotary switch settings do not agree with the value that is stored in the EEPROM. Connections at S11 and S21 were swapped after configuration. 	<ul style="list-style-type: none"> Return the switches/wiring to their proper settings/terminals and cycle power.⁽²⁾ Reconfigure the safety relay. <p>TIP Record the switch setting on the front face. For example, the logic setting is set to 3, but it should be set to 4.</p> 
		EMD	A jumper was added from B1 to B2 after configuration and power was later cycled.	
Flashing red 3 times	Invalid configuration on DI or DIS safety relay.	DI, DIS	<ul style="list-style-type: none"> During configuration, the Logic switch is set for IN1 OR IN2 (position 1, 3, 5, or 7), but the inputs are wired for safety mats. If the inputs are not closed during configuration, the DI and DIS safety relays show this fault on the next power cycle if the inputs are closed. 	<ul style="list-style-type: none"> Reconfigure the relays for IN1 AND IN2 (position 2, 4, 6, or 8). See Configuration on page 35 See additional information in Safety Mats on page 23.
Flashing red 4 times	Cross fault.	All	<ul style="list-style-type: none"> You modified the wiring after configuration. You wired up one or more input connections as a safety mat. When you stepped on the mat, the GSR relay went to fault mode. 	<ul style="list-style-type: none"> Check the wiring. Remove the short circuit and cycle the power. See additional information in Check Voltage-free Contacts on page 67.
		CI, DI, DIS, and SI	<ul style="list-style-type: none"> A short circuit occurred (and is no longer present) or is present from S11 to S21. Excessive capacitance is detected on input wiring to ground. The pulse tests waveform is distorted. 	
Flashing red 5 times	Output test has failed on L11.	CI	<ul style="list-style-type: none"> A short circuit has occurred, or is present, from +24V DC (A1) or S11 to L11. A short circuit has occurred, or is present, from 24V Common (A2) to L11 when L11 is ON. 	<ul style="list-style-type: none"> Correct the fault and cycle power to the GSR relays. See additional information in Check the Single Wire Safety Circuit (Step 4) on page 74.
		DI and DIS	<ul style="list-style-type: none"> Short circuit from L11 to L12 Short circuit from L11 to A1 on the next downstream relay. The 24V common connection to the downstream relay has temporarily disconnected. One of the downstream relays exhibited a momentary power interruption. For long SWS runs, L11 may be picking up noise. Consider running the SWS signal in shielded cable. 	
Flashing red 6 times	Output test has failed on 14, 24 ⁽¹⁾	DIS	<ul style="list-style-type: none"> External cross fault High capacitance load 	<ul style="list-style-type: none"> Check wiring. Remove fault or move high capacitance output connections to 34, 44. Cycle power to clear the fault. See additional information in OSSD Outputs on page 26.

(1) DIS safety relay only

(2) If you do not know the correct setting, you can rotate the switch to a new setting and cycle power. If the new setting does not agree with the EEPROM, the PWR/Fault indicator continues to flash 2X red; make a new selection and cycle power again. If the new setting agrees with the EEPROM, the PWR/Fault indicator is solid green, the GSR relay functions properly.

Table 12 - PWR/Fault Status Indicator Is Green with Flashing Red

Indicator	Description	Model	Possible Causes	Corrective Action
Green with flashing red 2 times	The configuration does not agree with the EEPROM.	All	One or more of the rotary switches have changed during operation.	The safety relay continues to operate, and the switches can be returned to their original position, while powered.
		EMD	On Version 200, B1 was jumpered to B2 after configuration. In Version 203, this condition is ignored.	Remove the jumper and the EMD functions properly.
Green with flashing red 3 times	B1-B2 connection.	All	B2 is connected to B1, after configuration. The fault indication occurs when the EMD output is energized. If the output is already energized, this fault will be detected on the next energization of the EMD.	<ul style="list-style-type: none"> Remove connection and fault is cleared automatically. See additional information in EMD Expansion Relay B1/B2 Inputs (Step 7) on page 86.
Green with flashing red 4 times	Retriggerable input.	EMD	Set for non-retriggerable and Logic IN input has turned off and then back ON before the time expired.	Cycle the Logic In input signal to clear the fault or let the timer expire and the fault clears automatically.
			A connection was made from terminals B1 to B2, after configuration.	Repeat the configuration process; the B1-B2 connection must be made before configuration. See additional information in EMD Expansion Relay B1/B2 Inputs (Step 7) on page 86 .

Check the Power Supply (Step 2)

The second troubleshooting step is to check the supply of power to your relay.

Check Voltage

If the PWR/Fault indicator is OFF, check the voltage by placing a digital multimeter on terminals A1 and A2 as shown in [Figure 58](#).

Figure 58 - Measure Power Supply Voltage

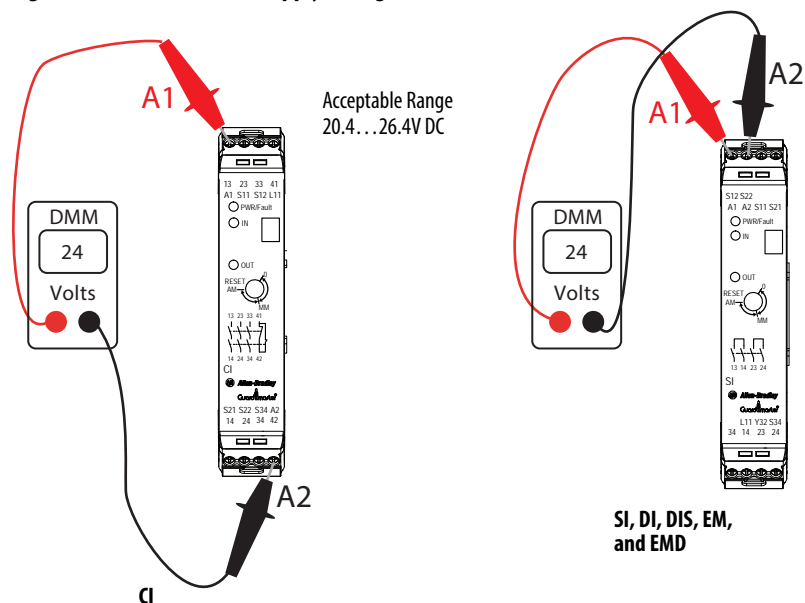

If the voltage is not within the acceptable range, verify that the power supply, wiring, circuit breakers, and/or fuses are functioning properly.

Verify Grounding at the Power Supply

IEC 60204-1 and NFPA79 require that the 24V is supplied by a PELV-rated power supply. The 24V common must be connected to protective earth, as shown in [Figure 59](#). The protective ground connection must only be in one location and is often best when closest to the power supply.

Ground loops and noise transients on the ground can cause the GSR relays to go into a fault state. This state is hard to capture. One method is to remove the protective grounding connection between machine ground and the 24V common temporarily. Then, wait to see if the fault does not occur (wait time varies). If the fault occurs, then the grounding scheme must be investigated further.

Figure 59 - 24V Common to Protective Earth Connection

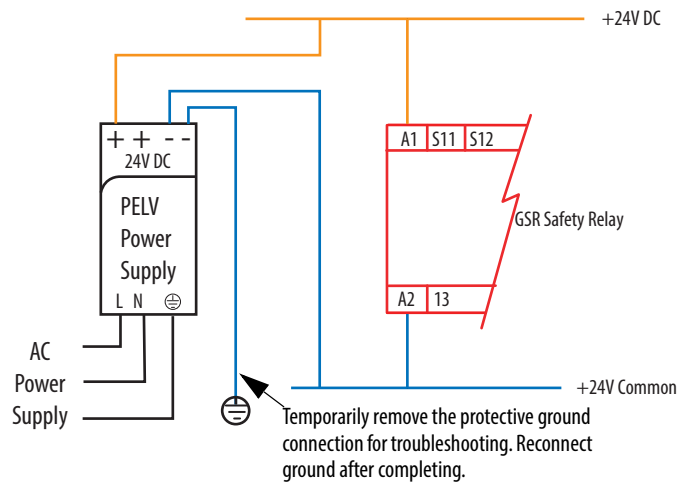

IEC 60204-1 edition 5.1 (Section 6.1) allows a SELV supply to be used when a PELV is not practicable due to physical or operational conditions. NFPA79 does not allow the use of a SELV supply. If you are meeting only IEC 60204-1, you can install a separate SELV supply for your safety system and leave it ungrounded (no protective ground).

Check Safety Device Inputs (Step 3)

This step only applies to CI, DI, DIS, and SI safety relays. Each safety relay has a status indicator for its inputs.

Table 13 - Input Indicator

IN, IN1, and IN2 Indicator	Status	Action
Green	Both channels are closed	Go to Check the Single Wire Safety Circuit (Step 4) on page 74 .
Off	One or both input channels are open	Continue with this section.

IMPORTANT The following factors affect the value that is measured at the relay inputs:

- Voltage-free contacts
- Pulse testing waveforms
- Capacitance
- Length of wire
- Contact resistance
- Channel sequence

Table 14 shows the voltage levels that are viewed on an oscilloscope versus a digital multimeter.

Table 14 - ON/OFF Voltage

Measurement Device	Turn ON Voltage	Turn OFF Voltage
Oscilloscope	11V	5V
Digital Multimeter	6...8V	3...4V

Check Voltage-free Contacts

Safety devices (for example; interlock switches, E-stops, or cable pull switches) with voltage-free contacts must be connected to the pulse testing outputs. You can use a digital multimeter to measure the input levels.

Check CI Safety Relay

1. With the device contacts open, measure the voltage at the pulse testing outputs with a digital multimeter, as shown in Figure 60. The voltage must be 18...19V on both pulse testing outputs of the CI safety relay.

Figure 60 - Typical Voltage Measurements of the CI Safety Relay

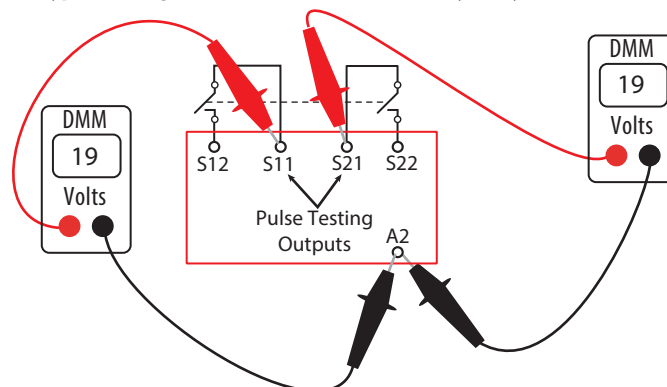

2. Check the voltage at each of the inputs with the device contacts closed, as shown in [Figure 61](#). The values must be very close to the values measured at terminals S11 and S21.
 - a. If both channels are closed, a voltmeter must read about 19V and the IN indicator is green. The voltage levels are approximately the same on Channel 1 (S12) and Channel 2 (S22) because the pulse testing waveforms are similar on both channels.
 - b. If only one input is above the turn ON voltage level, then the IN indicator is red.
 - c. Try cycling the input device.
 - d. If the contacts of the safety device do not operate consistently, the safety device must be replaced.

Figure 61 - Check the CI Safety Inputs with the Device Contacts Closed

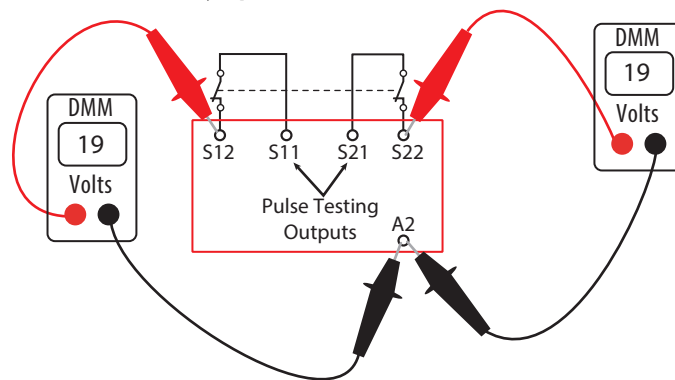

3. If a significant difference in voltage levels exists, see [Capacitance Effect on page 71](#) and [Long Wire — Resistance Effect on page 72](#).

To find where the voltage drop is occurring, you have to trace the wiring of the circuit that is not achieving at least 11V as measured by an oscilloscope.

Check DI, DIS, and SI Safety Relays

DI, DIS, and SI safety relays can also be checked in a similar fashion. The voltage of Channel 1 is lower (about 14V) than Channel 2 (about 18V). The reason for the difference in voltage levels is due to the difference in the pulse test wave forms (see [Figure 65 on page 70](#)). S11 is effectively OFF longer than S21.

1. Check the safety inputs with the device contacts open, as shown in [Figure 62](#).

TIP The SI safety relay does not have terminals S32 and S42.

Figure 62 - Typical Voltage Measurements of the DI, DIS, and SI Relays with Contacts Open

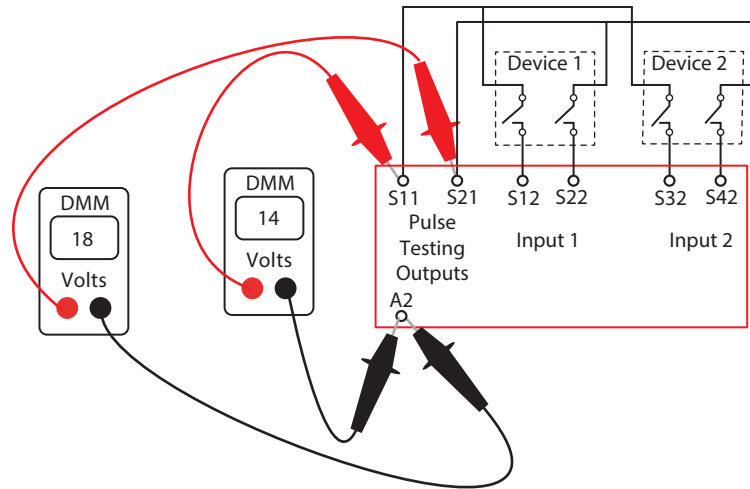

2. Check the voltage at each of the inputs with the device contacts closed. The values must be very close to the values measured at terminals S11 and S21.

Figure 63 - Typical Voltage Measurements of the DI, DIS, and SI Relays with Contacts Closed

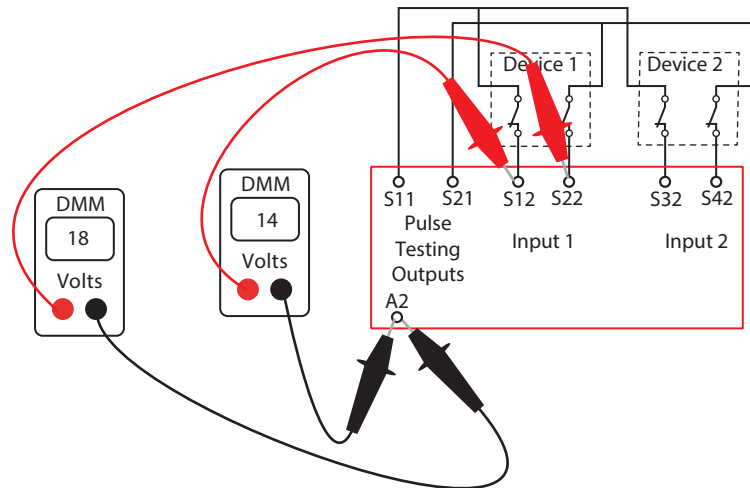

3. If a significant difference in voltage levels exists, see [Capacitance Effect on page 71](#) and [Long Wire — Resistance Effect on page 72](#).

Examine Pulse Test Waveforms

If you have an oscilloscope, you can examine the pulse tests. The test pulses are used to check for short-circuit conditions; the test pulses are not used to turn the inputs ON and OFF. If they are clean and square, then they are OK.

The test pulses are generated on terminals S11 and S21. The waveforms, which are shown in [Figure 64](#) and [Figure 65](#), must always be present on their respective relays; the test pulses cannot be turned off or adjusted.

Figure 64 - CI Safety Relay Pulse Test Waveforms

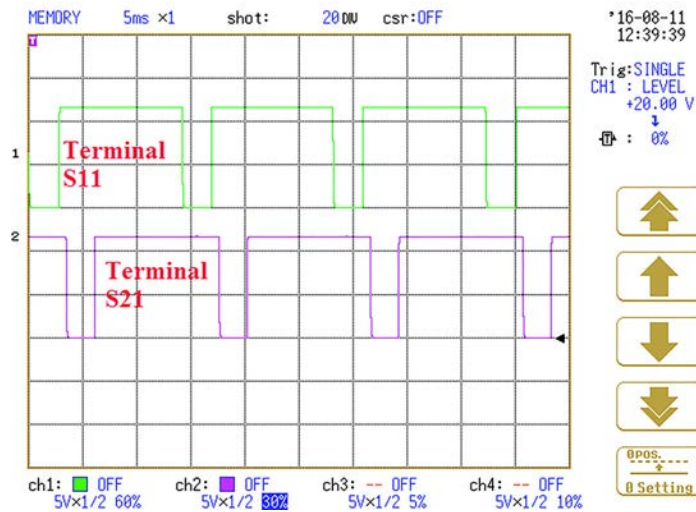
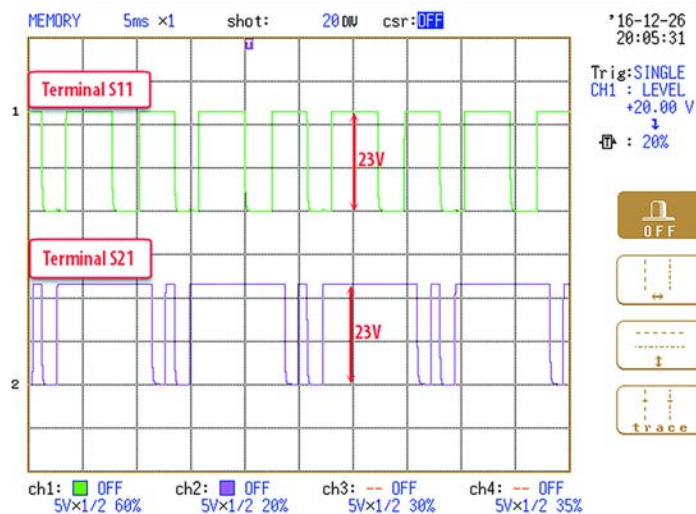

Figure 65 - DI, DIS, and SI Safety Relay Pulse Test Waveforms



Effect of OSSD Test Pulses

GSR relays cannot detect short circuits of OSSD device outputs. The PWR/Fault status indicator of your GSR relay remains solid green. The device with the OSSD outputs must detect short circuits of its own OSSD outputs. When

detected, the device must shut off both OSSD outputs and go to a faulted state. A status indicator must inform you that the OSSD device is faulted. See [Devices with OSSD Output on page 22](#) for more information.

Detect Off Pulses

When configured for monitored manual (or manual) reset, the GSR relay detects off pulses as described in [Table 15](#).

Table 15 - Off Pulses

Time	Description
Off time ≥25 ms	GSR relays always detect the input device turning OFF. GSR relays also detect that the input device has turned back ON.
7 ms < Off time < 25 ms	When the off pulse is between 7...25 ms, GSR relays turn their output OFF, but the input does not turn back ON. The input must be cycled again.
Off time <7 ms	GSR relays cannot detect inputs that turn OFF for 7 ms or less.

Test pulses on OSSD outputs are less than 1 ms; therefore the GSR relay ignores the test pulses.

Capacitance Effect

Capacitance leakage of the input wiring to ground causes a deformation of the leading edge of the pulses. [Figure 66](#) shows the deformation with 1 μF on each signal to ground. With this high capacitance, the CI safety relay still operates.

Capacitance from Ch1 to Ch2 looks the same as Ch1 to ground and Ch2 ground.

Figure 66 - Capacitive Effect on Pulse Tests

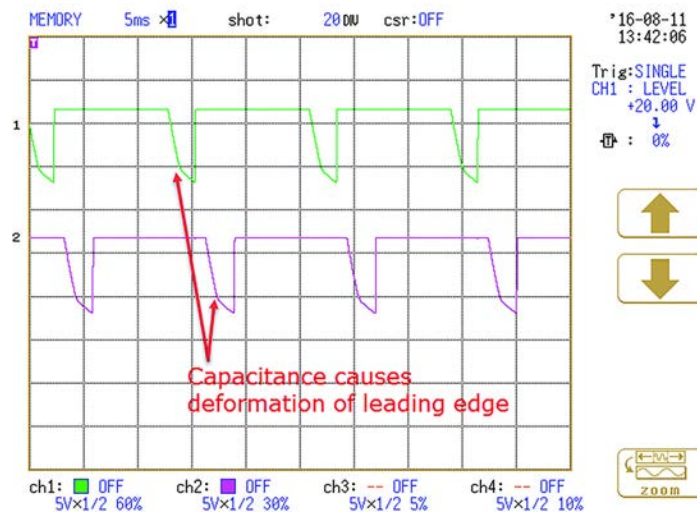

Long Wire — Resistance Effect

Long input wiring adds resistance and decreases the input signal voltage. [Figure 67](#) shows the effects on the pulse tests. Notice that the shape of the pulses has not changed, only the amplitude. If the wiring is too long, the safety relay does not turn ON.

Figure 67 - Resistance Effect on Input Signal

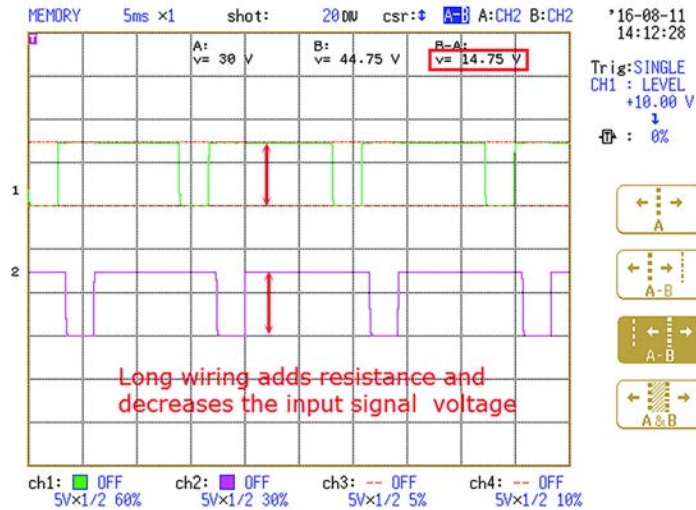

GSR relays have a maximum input resistance of 900 ohms.

[Table 16](#) shows the resistance of wire sizes that are typically used to connect to safety devices. For example, if you used 200 m (656.2 ft) of a 4-wire cable that contains 22 AWG wire, the wire resistance from the relay pulse test outputs to the safety device and back to the relay inputs, would be:

$$200 \text{ m} \times 52.94 \Omega / 1000 \text{ m} \times 2 \text{ directions} = 21 \Omega$$

As the example shows, long wires are not a likely cause of safety input issues.

Table 16 - Wire Resistance

ISO Cross Section [mm ²]	AWG	Ω Per 1000 m	Ω Per 1000 ft
0.33	22	52.94	16.14
0.5	20	33.30	10.15
0.75	18	20.95	6.386
1.5	16	13.18	4.016
2.5	14	8.28	2.525
4	12	5.21	1.588

Channel Simultaneity (Discrepancy)

GSR relays have infinite simultaneity (sometimes referred to as discrepancy). One channel can close (at T1) and the other channel can close much later (at T2), and the input circuit is satisfied. The order in which the channels close is not significant; either channel can close before the other (Figure 68).

Figure 68 - GSR Relays Have Infinite Simultaneity (Discrepancy)

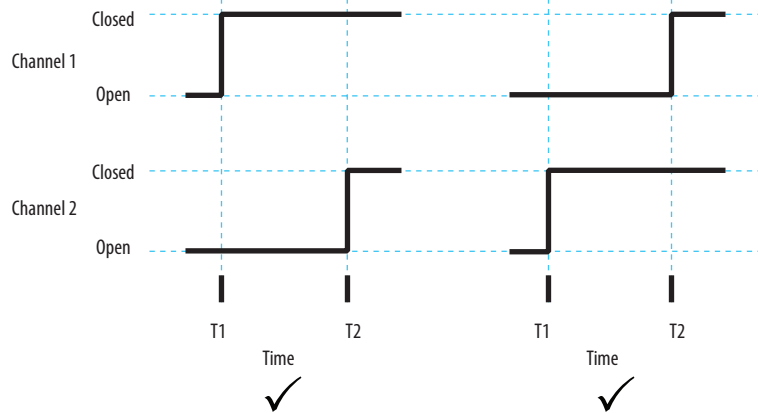

Multiple-channel Cycling

GSR relay inputs are not satisfied if one channel turns ON and OFF multiple times, followed by the closure of the second channel (Figure 69). The input status indicator remains red. This condition is not shown as a fault condition by the PWR/Fault status indicator. To clear this condition, open both channels and then reclose them.

Figure 69 - Multiple Cycles on One Channel Are Not Allowed

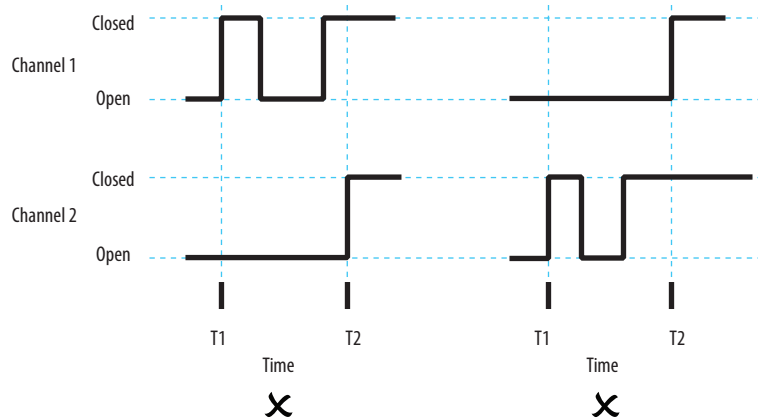

Recovery Time

Recovery time is a delay time that is required, measured from when the relay outputs turned OFF until they can turn back ON again. GSR relays have a 100 ms recovery time specification ([Figure 70](#)).

The GSR family of safety relays has conservative recovery time specifications. Actual measurements show the recovery time to be as fast as 20 ms. As a result, recovery time is unlikely to cause nuisance trips.

Figure 70 - Recovery Time

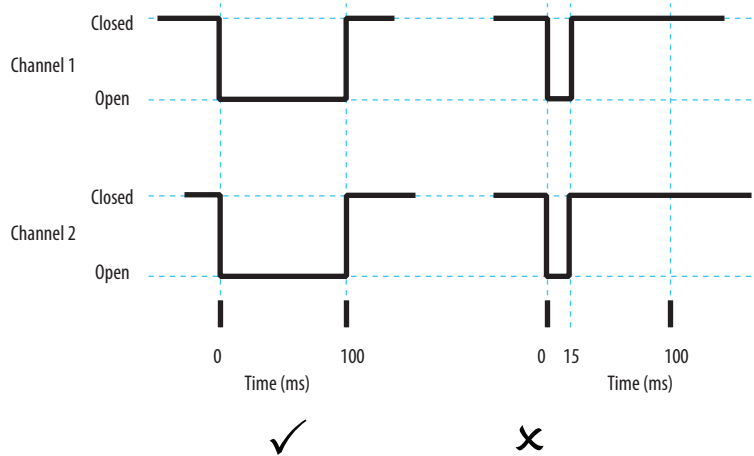

Check the Single Wire Safety Circuit (Step 4)

The Logic IN status indicator represents the single-wire safety (SWS) signal at terminal L12. The SWS output is terminal L11.

Check the Logic IN status indicator.

Table 17 - Logic IN Indicator

Logic IN Indicator	Status	Action
Green	L12 input is active (closed)	Go to Check the Reset/Monitoring Circuit (Step 5) on page 76 .
Off	L12 input is inactive (open)	See SWS Connections L11 and L12 .

SWS Connections L11 and L12

CI and SI safety relays only have SWS outputs (terminal L11); they do not have SWS inputs.

DI and DIS safety relays have both SWS input and output signals. If you have a DI or DIS safety relay and the SWS input signal is not used, then the Logic IN indicator is always OFF. If no wire is connected to terminal L12, then make sure that the LOGIC switch is set to either 1, 2, 5, or 6 (switch positions with OR logic).

EM or EMD expansion relays have both SWS input and output signals. You must connect a wire to L12. Your application requirements determine whether L11 is used.

[Figure 71](#) shows an example of an SWS connection. Note the L11 terminal (which is the SWS output) can be connected to multiple L12 terminals (SWS input), but the L12 terminal cannot be connected to multiple L11 terminals.

Figure 71 - Example SWS Connections

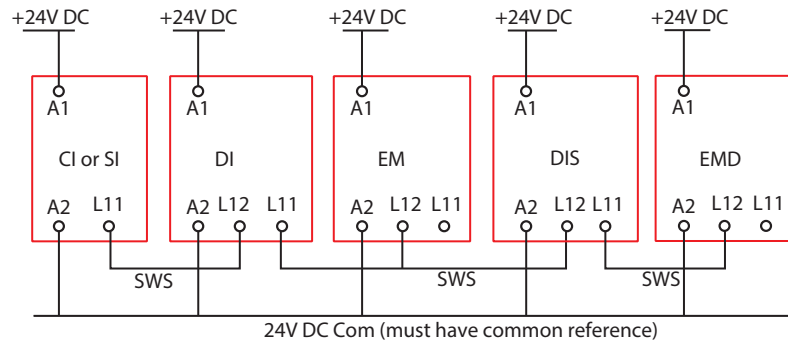

TIP For long wire runs of the SWS signal, a shielded cable may be necessary to help prevent nuisance faults from electromagnetic and motor noise.

[Figure 72](#) shows the characteristics of SWS signal when it is active. It starts with a 1 ms pulse, followed 700 μ s later by a 500 μ s pulse. This waveform is repeated every 4 ms. When inactive, the SWS is 0V.

Figure 72 - SWS Waveform



When the signal is active, use a digital multimeter to measure the voltage. The digital multimeter shows 8...9V.

If a fault occurs with either an SWS input or SWS output, then that circuit is held high. If a digital multimeter reads a voltage measurement of approximately 21V, the signal is high. The PWR/Fault status indicator flashes red five times.

Check the Reset/Monitoring Circuit (Step 5)

The OUT status indicator blinks green when the inputs to the GSR relay are satisfied and the GSR relay is ready to turn on its outputs. The OUT status indicator flashes green at a 1 Hz rate. The GSR relay is waiting for the appropriate reset signal at terminal S34.

If the OUT status indicator is blinking green, but the relay does not turn on its outputs when the reset button is pressed, measure the voltage at terminal S34 (point 1) as shown in [Figure 73](#). If 24V is not present when the reset button is pushed, then check the other connections (points 2...7) in the circuit. If 24V is present at terminal S34, then you must consider the reset configuration:

- **Automatic/Manual:** The GSR relay must be replaced as the output indicator must turn solid green as soon as the voltage was present at terminal S34.
- **Monitored/Manual:** If the output indicator does not turn solid green when voltage at S34 is present between 0.25...3 seconds, then GSR relay must be replaced.

Figure 73 - Measure Reset/Monitoring Circuit Voltage

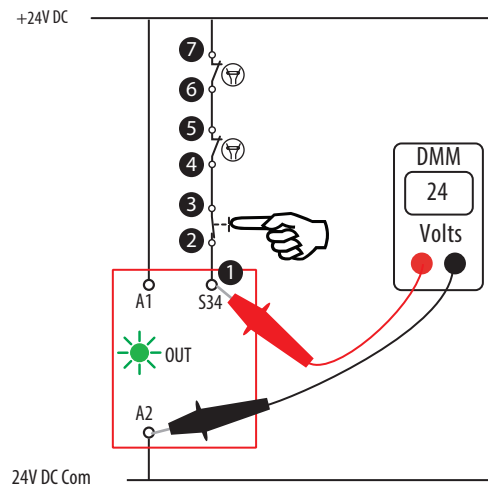

Two-handed Reset Operation

Does your application have an E-stop mounted close to the reset button, which allows you to release the E-stop with one hand and press the reset button with the other? Does your application let you close a safety gate with one hand and press the reset button with the other hand? These configurations are not a problem with GSR relays because the reset signal can be pressed 10 ms after the relay inputs are satisfied.

Applications with OSSD Outputs and Test Pulses

If your application uses an OSSD output with test pulses as the source of my reset signal, do the GSR relays execute the reset function properly as shown in [Figure 74](#)?

Test pulses are much less than 1 ms wide. GSR relays ignore test pulses up to 6 ms in duration. [Figure 74](#) shows a reset signal that is 2500 ms long. During this time, a 6 ms test pulse occurs. This test pulse is ignored. A test pulse of 7 ms causes the GSR relay to execute the reset function, provided the test pulse occurs after 250 ms.

Figure 74 - Reset Input Ignores Test Pulses up to 6 ms

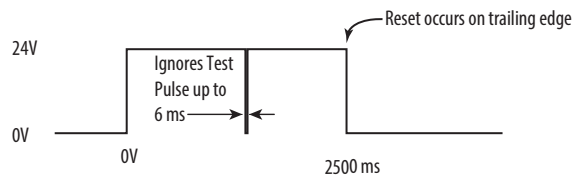

Check the Safety Outputs (Step 6)

The GSR family of relays has two types of outputs:

- **Electromechanical outputs:** CI, DI, EM, EMD, and SI safety relays
- **OSSD outputs:** DIS safety relay

Electromechanical Output Issues

If the OUT status indicator is solid green, but the output device does not energize begin troubleshooting by measuring the terminal voltage.

Measure the Terminal Voltage

Confirm that voltage is present at the relay terminals and the load. [Figure 75](#) shows an example of the measurement points for one output channel (13/14). Since most safety circuits consist of two channels, repeat the checking on the second channel (23/24).

Figure 75 - Measure the Terminal Voltage

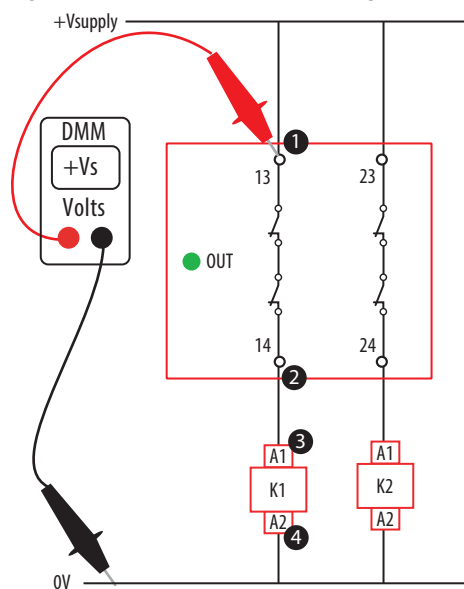

Step	Description
1	The voltage at 13 must be the same as the supply voltage. If not check for an open circuit (broken wire), blown fuse, or tripped circuit breaker.
2	The voltage at 14 must be the same as the supply voltage. If not, the positive-guided relay inside the GSR relay is not closing. Measure the contact resistance; see Figure 76 on page 79 .
3	The voltage at A1 must be the same as the supply voltage. If not, check for an open circuit (broken wire) between terminal 14 and A1.
4	The voltage at A2 must be zero. If not, check for an open circuit between A1 and the voltage supply ground connection. If A2 measures zero volts and A1 measures the supply voltage, then K1 is not operating properly and must be replaced.

Measure the Contact Resistance

If the voltage at terminal 13 is the same as the supply voltage, but terminal 14 measures zero volts measure the contact resistance.



SHOCK HAZARD: Turn off power before power connection is removed if +Vsupply is greater than 50V.

Measure the contact resistance to confirm that the relay is not functioning properly. As shown in [Figure 76](#), remove the power wires to terminal 13 and set the digital multimeter to ohms. Be sure that the OUT status indicator is green.

The contact resistance must be less than 1 ohm. If it is not, then the internal positive-guided relay is not functioning properly, and the GSR relay must be replaced.

Figure 76 - Measure the Contact Resistance

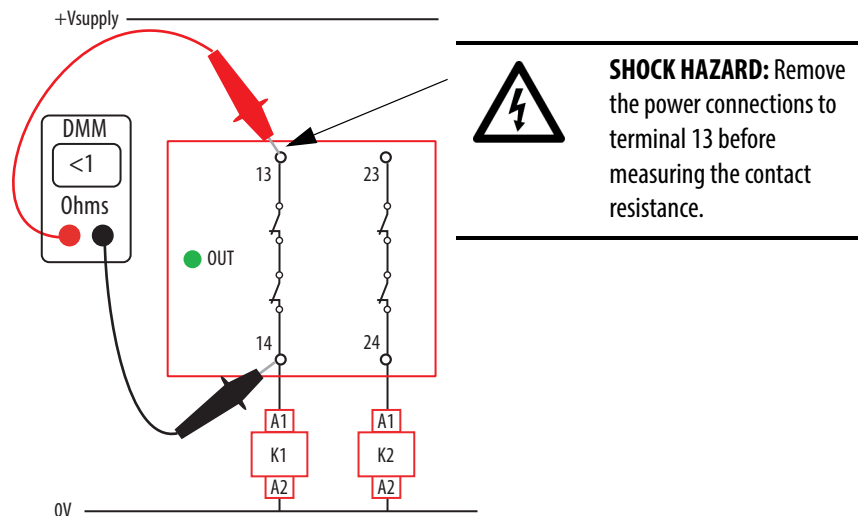

OSSD Output Issues

If the OUT status indicator is solid green, but the output device that is connected to terminal 14 or 24 does not energize, begin troubleshooting by checking the voltage at the output connections. See [Check the OSSD Connections](#).

If the OUT status indicator is solid green, but the PowerFlex drive is providing indication that the safety circuit is open, check the connections to the PowerFlex drive. See [Check the PowerFlex Drive Connections on page 80](#).

Check the OSSD Connections

Confirm that voltage is present at the relay terminals and the load. [Figure 77](#) shows an example of the measurement points for one output channel (terminal 14). Since most safety circuits consist of two channels, repeat the checking on the second channel (terminal 24).

Figure 77 - OSSD Output Connections

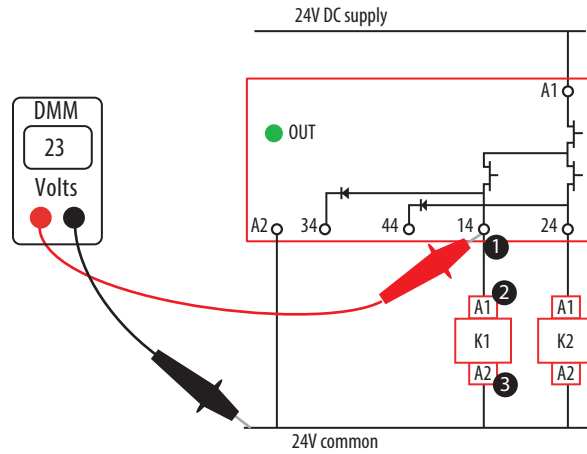

Step	Description
1	The voltage at 14 must be slightly less than the supply voltage. If not, then the DIS relay must be replaced.
2	The voltage at A1 must be slightly less than the supply voltage and must be the same voltage as measured at terminal 14. If not, check for an open circuit (broken wire) between terminal 14 and A1.
3	The voltage at A2 must be zero. If not, check for an open circuit between A1 and the voltage supply ground connection. If A2 measures zero volts and A1 measures the supply voltage, then K1 is not operating properly, and must be replaced.

Check the PowerFlex Drive Connections

Confirm that voltage is present at the relay terminals and the safety input terminals of the PowerFlex drive. [Figure 78](#) shows an example of the measurement points for one output channel (terminal 34). Repeat the checking on the second channel (terminal 44). The terminal connections from 34 and 44 to S1 and S2 can be reversed.

Figure 78 - Typical Connections to PowerFlex Drive

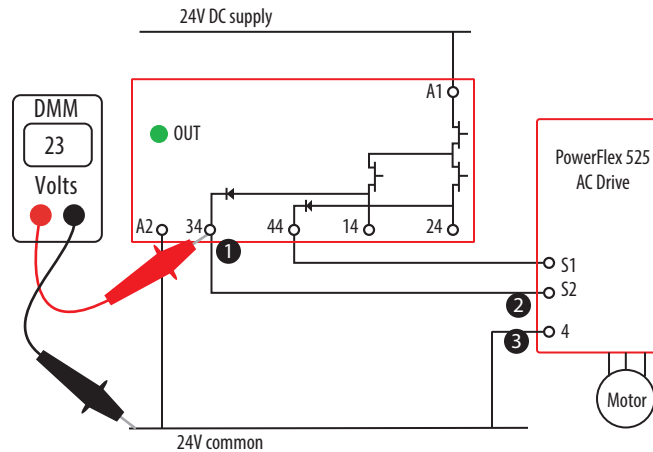

Step	Description
1	The voltage at 34 must be slightly less than the supply voltage. If not, then the DIS relay must be replaced.
2	The voltage at S2 must be slightly less than the supply voltage and must be the same as the voltage at terminal 34. If not, check for an open circuit (broken wire) between terminal 34 and S2.
3	The voltage at terminal 4 must be zero. If not, check for an open circuit between terminal 4 and the voltage supply ground connection. Figure 79 shows how to verify the continuity from terminal 4 of the drive to terminal A2 of the DIS safety relay.

[Figure 79](#) shows the test connections to verify the common reference between the DIS safety relay and the AC Drive. Remove power from the application and set the digital multimeter to ohms. If possible, measure directly at the terminals. The resistance must be less than 1 ohm.



SHOCK HAZARD: Turn power OFF before continuity is tested.

Figure 79 - Continuity Test of the Voltage Supply Common Connection

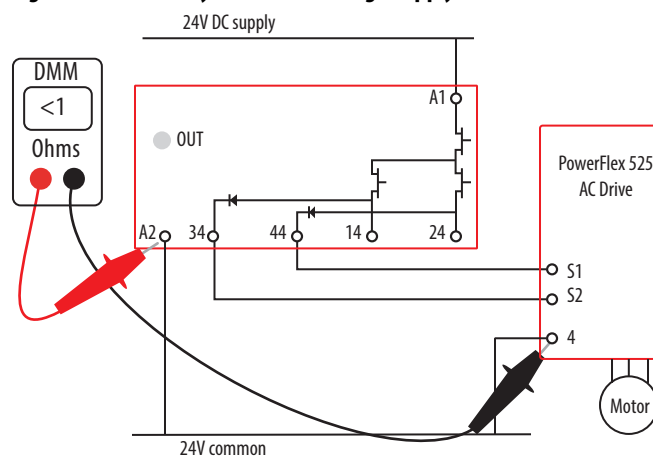

The OSSD test pulses of the DIS safety relay, as viewed by an oscilloscope, are shown in [Figure 80](#) and [Figure 81 on page 82](#). Most often, the main transistor triggers the scope; this test pulse appears on all four terminals simultaneously.

The main transistor pulses are about 110 μs wide. Each channel is tested individually as shown in Figure 81. The individual pulses are about 50 μs wide. These pulse widths are provided for informational purposes; the pulses cannot be turned OFF or adjusted.

Figure 80 - OSSD Main Transistor Test Pulses

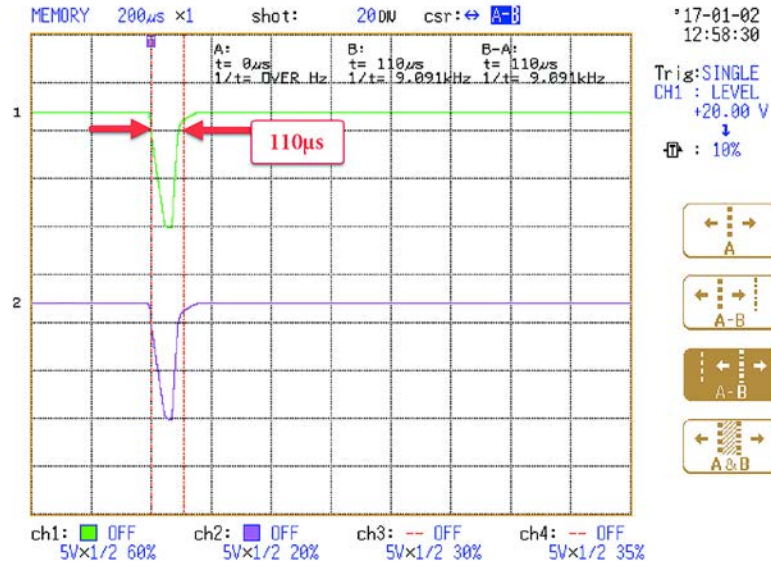
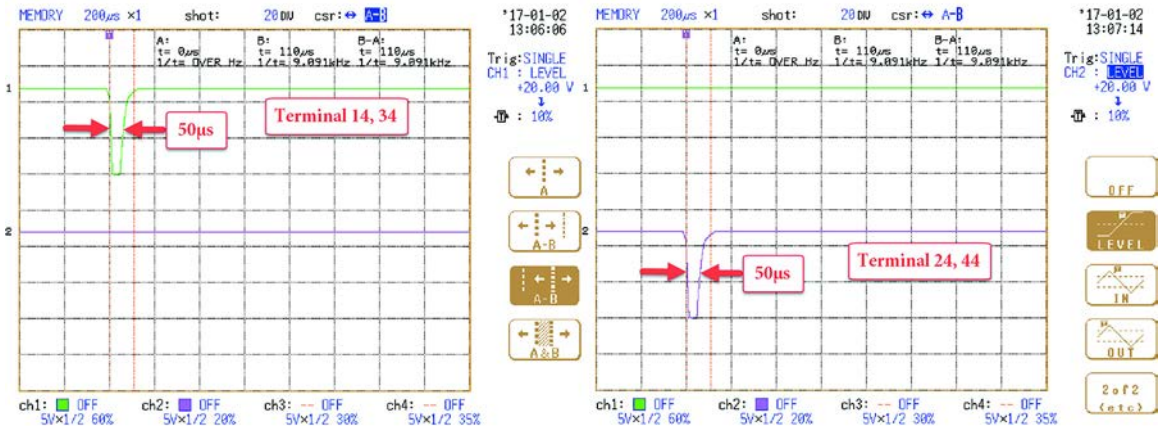

Figure 81 - OSSD Channel Transistor Test Pulse



Auxiliary Output Issues

Table 18 - Auxiliary Output Issues

State	Symptom	Action
The OUT status indicator is OFF.	My PLC does not know that the relay is OFF or my auxiliary status indicator does not turn ON.	See Measure the Auxiliary Output Terminal Voltage on page 83 .
	The voltage at terminal 41 is the same as the supply voltage. However, terminal 42 measures 0V.	See Measure the Contact Resistance on page 84 .
	Terminal Y32 does not turn ON.	See Check the Y32 Output on page 84 .
	Terminal X32 does not turn ON.	See Check the X32 Output on page 85 .
The safety outputs are OFF.	The Y32 output must be ON. This is true for both faulted and running states.	See Check the Y32 Output on page 84 .

TIP For more information on auxiliary outputs, see [Auxiliary Output on page 29](#).

Measure the Auxiliary Output Terminal Voltage

When OUT status indicator is OFF, my PLC does not know that the relay is OFF or my auxiliary status indicator does not turn ON.

Confirm that voltage is present at the relay terminals and the load. [Figure 82](#) shows an example of the measurement points for one output channel (41/42).

Figure 82 - Measure Voltage Aux Output Terminals

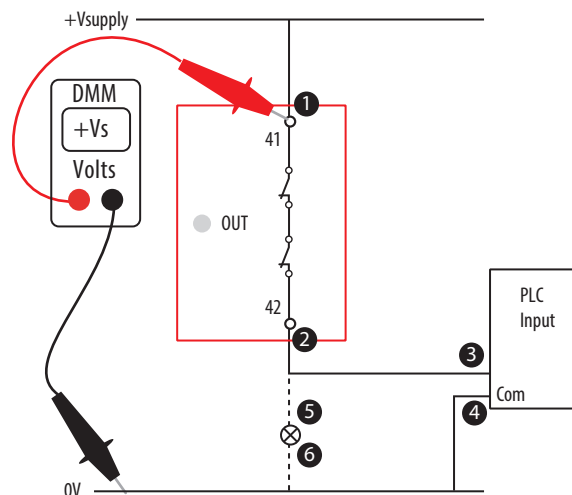

Step	Description
1	The voltage at 41 must be the same as the supply voltage. If not, check for an open circuit (broken wire), blown fuse, or tripped circuit breaker.
2	The voltage at 42 must be the same as the supply voltage. If not, the positive-guided relay inside GSR relay is not closing. Measure the contact resistance; see Figure 83 .
3	The voltage at the PLC input must be the same as the supply voltage. If not, check for an open circuit (broken wire), a bad contact at a terminal connection), or go to step 4.
4	Place the black test probe on the PLC common terminal. Verify that the common of the PLC is connected to the common of the voltage supply.
5	The aux output voltage at one side of the auxiliary status indicator must be the same as the supply voltage. If not, check for an open circuit (broken wire) between terminal 14 and aux status indicator.
6	Verify that the aux status indicator is connected to the voltage supply common. The aux status indicator must be replaced.

Measure the Contact Resistance

The OUT status indicator is OFF, and the voltage at terminal 41 is the same as the supply voltage. However, terminal 42 measures 0V.



SHOCK HAZARD: Turn off power before power connection is removed if +Vsupply is greater than 50V.

Measure the contact resistance to confirm that the relay is not functioning properly. As shown in [Figure 83](#), remove the power wires to terminal 41 and set the digital multimeter to ohms. Be sure that the OUT status indicator is OFF.

The contact resistance must be less than 1 ohm. If it is not, then the internal positive-guided relay is not functioning properly, and the GSR relay must be replaced.

Figure 83 - Measure Contact Resistance of Aux Output Terminals

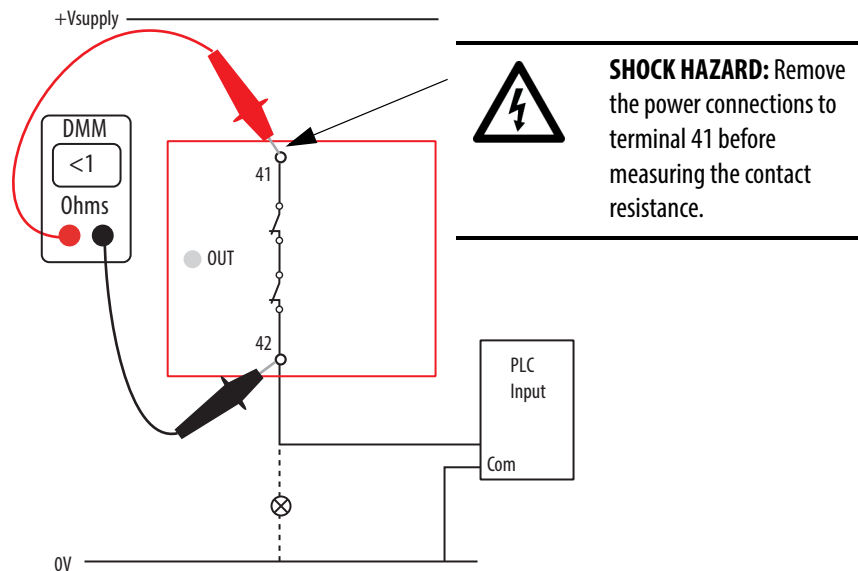

Check the Y32 Output

When OUT status indicator is OFF, terminal Y32 does not turn ON. Or, when the safety outputs are OFF, the Y32 output must be ON. This is true for both faulted and running states.

Use a digital multimeter to measure the voltage at Y32 (point 1 in [Figure 84](#)). The voltage must be around 23V DC. [Figure 84](#) shows a typical schematic for the aux output - the aux signal can go to a PLC input or to an indicator on a control panel. If it is 23V, then check the remaining points (2...5). If Y32 measures zero volts, then the relay must be replaced.

Figure 84 - Measure Y32 Voltage

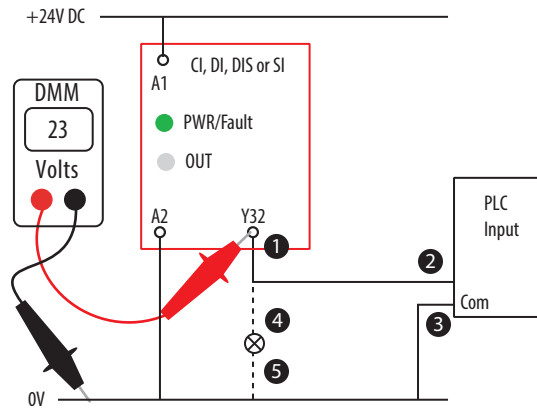

Check the X32 Output

When OUT status indicator is OFF, terminal X32 does not turn ON.

TIP This is proper operation for the EM and EMD relays if they are in a non-recoverable faulted state. If so, then the PWR/Fault status indicator is solid red or flashing red.

Correct the fault and cycle power. The relay may need to be reconfigured to correct the fault.

If the PWR/Fault status indicator is green, then measure the voltage at terminal X32 with a digital multimeter. [Figure 85](#) shows a typical usage of X32 (point 1) as the source for the monitoring circuit. The voltage must be around 23V DC. If it is 23V, then follow the circuit and check the voltage at each of the remaining points (2...6). If X32 measures 0V, then the relay must be replaced.

Figure 85 - Measure X32 Voltage

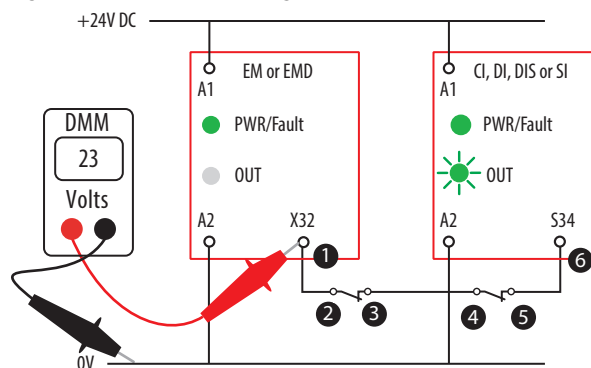

EMD Expansion Relay B1/B2 Inputs (Step 7)

Figure 86 shows the waveform from B1 to B2. This waveform is the same as the single wire safety waveform. The waveform is present only when the output of the EMD expansion relay is ON. With a digital multimeter, the voltage measures 8...9V DC.

If the B1 status indicator is on, but no voltage is read, your expansion relay must be replaced.

TIP For more information on retriggerable inputs, see [page 33](#).

Figure 86 - The B1-B2 Waveform When the EMD Output is ON

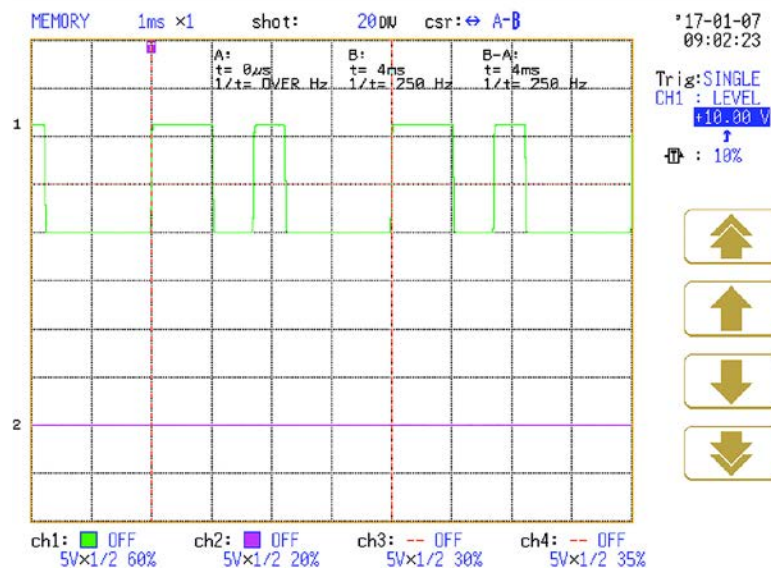

Terminal Block Removal and Replacement

Terminal blocks can be replaced following these instructions.

Terminal Block Removal

GSR relays have removable terminal blocks. Use a screwdriver as a lever to remove the blocks. As shown in [Figure 87](#), insert the screwdriver into the slot and pry up.

Figure 87 - Terminal Block Removal

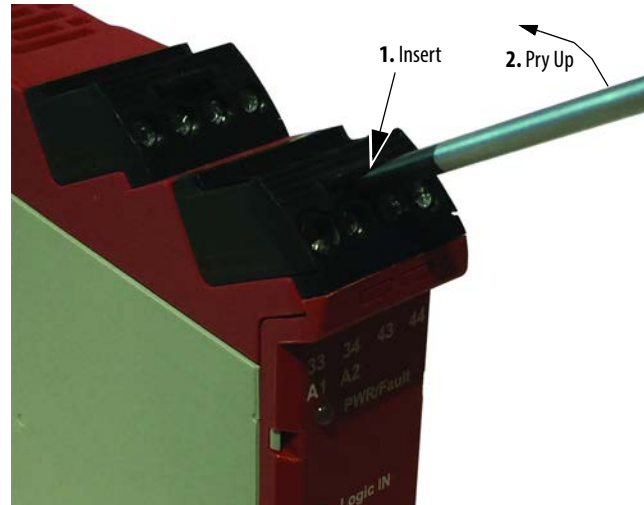

Terminal Block Replacement

The terminal blocks are keyed to help prevent a block from being inserted into an incorrect location. The orange-colored insert provides the orientation of the key ([Figure 88](#)).

Figure 88 - Orange-colored Keyway

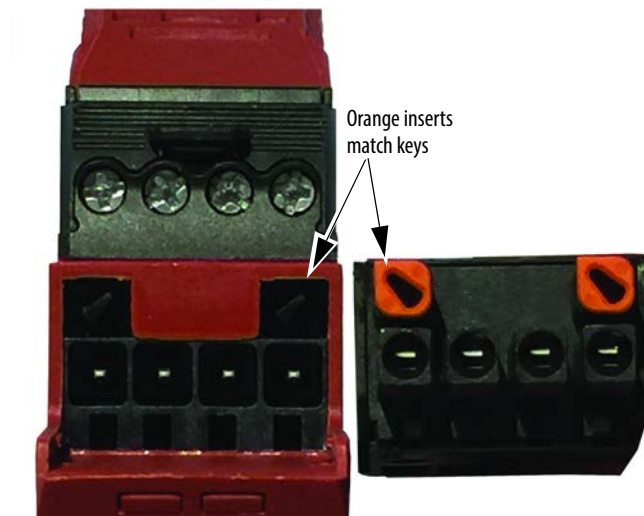

Series, Version, and Manufacturing Date Code

The product label differs slightly depending on when you purchased your relay.

Current Product Label

The series, firmware revision number, and manufacturing date code are identified on the safety relay label, as shown in [Figure 89](#).

Figure 89 - Product Label - Series and Revision Identification

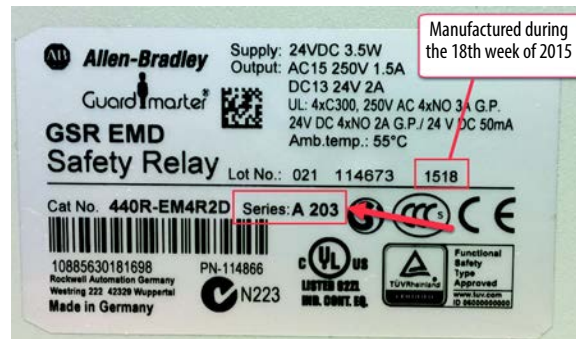

Old Product Label

The initial production runs of GSR relays excluded a firmware revision number, as shown in [Figure 90](#).

Figure 90 - Early Version of Product Label

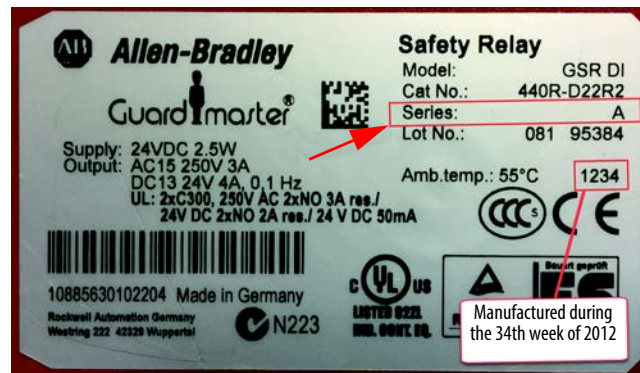

Specifications

General

Table 19 - General Specifications

Attribute	440R-S13R2 (CI)	440R-D22R2 (DI)	440R-D22S2 (DIS)	440R-EM4R2 (EM)	440R-EM4R2D (EMD)	440R-S12R2 (SI)
Dimensions, HxWxD [mm (in)]	119.14 x 22.5 x 113.6 (0.88 x 4.69 x 4.47)					
Shipping Weight, Approx. [g (lb)]	225 (0.5)	180 (0.4)	50 (0.33)	225 (0.5)	220 (0.49)	150 (0.33)
Wire Size [mm ² (AWG)]	0.2...2.5 (24...14)					
Wiring Category	Copper that withstands 75 °C (167 °F)					
Terminal Screw Torque [N-m (lb-in)]	0.4 (4)					
Power Supply Voltage Range	24V DC PELV/SELV, 0.85...1.1 x rated voltage					
Power On Delay [s]	5.5					
Power Consumption [W]	3.5	2.5	2	3.5	3.5	2.5
Case Material	Polyamide PA 6.6					
Terminal Protection	IP20					
Enclosure Protection	IP40 (NEMA 1)					
Mounting	35 mm DIN rail in enclosure that is rated to a minimum of IP54					

Environmental

Table 20 - Environmental Specifications

Attribute	440R-S13R2 (CI)	440R-D22R2 (DI)	440R-D22S2 (DIS)	440R-EM4R2 (EM)	440R-EM4R2D (EMD)	440R-S12R2 (SI)
Temperature, Operating [°C (°F)]	-5...+55 (23...131)					
Relative Humidity	90%					
Vibration	10...55 Hz, 0.35 mm					
Shock	10 g, 16 ms					
Pollution Level	2					
Installation Group	Overvoltage Category III, VDE 0110-1					
Impulse Withstand Voltage	2500V					

Safety Inputs IN, IN1, and IN2

Table 21 - Safety Inputs IN, IN1 and IN2 Specifications

Attribute	440R-S13R2 (CI)	440R-D22R2 (DI)	440R-D22S2 (DIS)	440R-EM4R2 (EM)	440R-EM4R2D (EMD)	440R-S12R2 (SI)
Inputs	1 NC, 1 PNP (OSSD)	2 NC, 2 PNP (OSSD)	2 NC, 2 PNP (OSSD)	—	—	1 NC, 1 PNP (OSSD)
Wiring Terminals	S12, S22	S12, S22 and S32, S42	S12, S22 and S32, S42	—	—	S12, S22
ON Voltage	Max [V]	26.4		—	—	26.4
	Min [V]	11		—	—	11
OFF Voltage, Max [V]	5		—	—	5	
OFF Current, Max [mA]	2		—	—	2	
ON Current, Max	At 24V DC [mA]	11.0		—	—	11.0
	At 26.4V DC [mA]	11.1		—	—	11.1
Galvanic Isolation: I/O from Logic	No		—	—	No	
Overvoltage Protection	Yes		—	—	Yes	
Test Out Pulse	Duration [ms]	2.5	1.5, 3	—	—	1.5, 3
	Period [ms]	14	13.6	—	—	13.6
Off Pulse Accepted for OSSD Setting Without Declaring the Input as OFF, Max [ms]	3.1	2.2		—	—	2.2
Recovery Time, Min [ms]	30		—	—	30	
Reverse Voltage Protection	Yes		—	—	Yes	
Input Capacitance [nF]	10		—	—	10	
Input Simultaneity	Infinite		—	—	Infinite	
Allowable Input Resistance, Max (Ω)	900		—	—	900	
Allowable Cable Capacitance, Max [nF]	S11 to S21	350	160	—	—	160
	S11 to Ground	350	320	—	—	320
	S21 to Ground	350	320	—	—	320
Safety Mat, Max Size [m ²]	23	35		—	—	35

Reset Input

Table 22 - Reset Input Specifications

Attribute	440R-S13R2 (CI)	440R-D22R2 (DI)	440R-D22S2 (DIS)	440R-EM4R2 (EM)	440R-EM4R2D (EMD)	440R-S12R2 (SI)
Wiring Terminal	S34		—	—	—	S34
ON Voltage	Max [V]	26.4		—	—	26.4
	Min [V]	11		—	—	11
OFF Voltage, Max [V]	5		—	—	5	
OFF Current, Max [mA]	2		—	—	2	
ON Current, Max	At 24V DC [mA]	11.0		—	—	11.0
	At 26.4V DC [mA]	11.1		—	—	11.1
Galvanic Isolation: I/O from Logic	No		—	—	No	
Overvoltage Protection	Yes		—	—	Yes	
Input Capacitance [nF]	10		—	—	10	
Duration [s]	0.5...3.0		—	—	0.5...3.0	

B1 Input

Table 23 - B1 Input Specifications

Attribute	440R-S13R2 (CI)	440R-D22R2 (DI)	440R-D22S2 (DIS)	440R-EM4R2 (EM)	440R-EM4R2D (EMD)	440R-S12R2 (SI)
Wiring Terminal	—	—	—	—	B1	—
ON Voltage	Max [V]	—	—	—	26.4	—
	Min [V]	—	—	—	11	—
OFF Voltage, Max [V]	—	—	—	—	5	—
OFF Current, Max [mA]	—	—	—	—	2	—
ON Current, Max	At 24V DC [mA]	—	—	—	11.0	—
	At 26.4V DC [mA]	—	—	—	11.1	—
Galvanic Isolation: I/O from Logic	—	—	—	—	No	—
Overvoltage Protection	—	—	—	—	Yes	—
Input Capacitance [nF]	—	—	—	—	10	—

Safety Outputs

Table 24 - Safety Outputs Specifications

Attribute	440R-S13R2 (CI)	440R-D22R2 (DI)	440R-D22S2 (DIS)	440R-EM4R2 (EM)	440R-EM4R2D (EMD)	440R-S12R2 (SI)	
Wiring Terminal	13/14, 23/24, 33/34	13/14, 23/24	14, 24, 34, 44	13/14, 23/24, 33/34, 43/44	17/18, 27/28, 37/38, 47/48	13/14, 23/24	
Output Type	3 N.O.	2 N.O.	4 PNP	4 N.O.	4 N.O. delayed	2 N.O.	
Thermic Current I_{th}	1 x 6 A		—	1 x 6 A			
Fuses output (external)	6 A slow blow or 10 A quick blow		—	6 A slow blow or 10 A quick blow			
Switched Current, Min [mA]	10		—	10			
Switched Voltage, Min [V]	10		—	10			
Mechanical Life	10,000,000 cycles		—	10,000,000 cycles			
Rating	UL: C300 AC-15: 1.5 A / 250V AC DC13: 2 A / 24V DC (0.1 Hz)		14, 24: 1.5 A each 34, 44: 0.5 A each	UL: B300 AC-15: 1.5 A / 250V AC DC13: 2 A / 24V DC (0.1 Hz)		UL: C300 AC-15: 1.5 A / 250V AC DC13: 2 A / 24V DC (0.1 Hz)	
Capacitance	—		14, 24: 1.6 μ F each 34, 44: 9 μ F each	—			
Contact material	AgNi	AgNi + 0.2 μ Au	—	AgNi			
Reaction Time Safety Output [ms]	L12	45	35	100	150	150	
	Inputs	35	25				
	Mat Operation	40	30				
Reaction Time Single Wire Safety Output [ms]	L12	35	35	0	150	—	
	Inputs	25	25			25	
	Mat Operation	30	30			30	
Response Time Safety Output [ms]	Inputs	35	25	35		35	
	Mat Operation	45	40			30	45
Response Time Single Wire Safety Output [ms]	Inputs	25	25	25		25	
	Mat Operation	35	30			30	35
	Single-wire Fault	45	45			45	45
Recovery Time [ms]	100	100	100	150	150	100	

Auxiliary Output

Table 25 - Auxiliary Output Specifications

Attribute	440R-S13R2 (CI)	440R-D22R2 (DI)	440R-D22S2 (DIS)	440R-EM4R2 (EM)	440R-EM4R2D (EMD)	440R-S12R2 (SI)
Wiring Terminal	—	Y32		X32		Y32
Output Type	1 N.C.			1 PNP, 50 mA max		

Single Wire Safety

Table 26 - Single Wire Safety (SWS) Specifications

Attribute	440R-S13R2 (CI)	440R-D22R2 (DI)	440R-D22S2 (DIS)	440R-EM4R2 (EM)	440R-EM4R2D (EMD)	440R-S12R2 (SI)
Wiring Terminal	Output - L11 Input - L12					
Continuous Output Current, Max [mA]	50					
ON State Voltage Drop (P/S to +), Max [V]	0.2					
Surge Output Current, Max [mA]	700					
Surge Output Current Duration, Max [ms]	5					
Load Capacitance, Max [µF]	1					
Off State Leakage Current, Max [mA]	< 0.1					
Short Circuit Detection	No					
Short Circuit Protection	Yes					
Galvanic Isolation: I/O from Logic	No					
Fanout (Max number of connections to L11)	10					
Cable length between L11 and L12 [m]	30					

Regulatory Approvals

Agency Certifications

- UL Listed Industrial Control Equipment, certified for US and Canada.
- CE marked for all applicable directives
- C-Tick marked for all applicable acts
- CCC Mark
- S-Mark

Compliance to European Union Directives

This product has the CE marking and is approved for installation within the European Union and EEA regions. It has been designed and tested to meet the following directives.

EMC Directive

This product is designed and tested to meet the European Council Directive 2004/108/EC on Electromagnetic Compatibility (EMC) and the following standards:

- EN 61000-6-4: Generic Standards - Emission Standard for Industrial Environments
- EN 61000-6-2: Generic Standards - Immunity for Industrial Environments

This product is intended for use in an industrial environment.

Machine Safety Directive

This product is designed and tested to meet the European Council Directive 2006/42/EC on machinery and the following standards.

- IEC/EN 61508 - Functional safety of electrical/electronic/programmable electronic safety-related systems
- IEC/EN 62061 - Safety of machinery - Functional safety of safety-related electrical, electronic, and programmable electronic control systems
- EN ISO 13849-1 - Safety of machinery -- Safety-related parts of control systems -- Part 1: General principles for design

This product is intended for use in an industrial environment.

The performance of the safety function is dependent on the structure of all devices that comprise the safety function. [Table 27](#) and [Table 28](#) provide the data that must be used to represent safety relays when calculating the safety integrity level (SIL) or the Performance Level (PL).

Safety relays can be used in safety circuits according to DIN EN 60204-1/VDE 0113 part 1. The following safety requirements are achievable in maximum based on the operation mode and wiring.

Specifications are applicable only if the safety function is demanded at least once within six months. All diagnostic tests are conducted at least before next demand. At mission time (TM), the proof test interval (PTI) is assumed. Components failure rates are according to SN29500.

SIL Rating

Safety relays meet the requirements in [Table 27](#) in accordance with IEC/EN 61508 and IEC 62061.

Table 27 - SIL Rating

	440R-S13R2 (CI)	440R-D22R2 (DI)	440R-D22S2 (DIS)	440R-EM4R2 (EM)	440R-EM4R2D (EMD)	440R-S12R2 (SI)
PFH (1/h)	4.26 E-09	4.35 E-09	4.39 E-09	1.81 E-09	4.40 E-09	3.98 E-09
Safety Integrity Level Claim Limit	3					
Mode of Operation	High demand					
Hardware Fault Tolerance	1					
Safe Failure Fraction	99%					

Performance Level/Category

Safety relays can be used in safety systems that meet up to Category 4 and Performance Level PLe in accordance with ISO 13849-1

Table 28 - Performance Level/Category

	440R-S13R2 (CI)	440R-D22R2 (DI)	440R-D22S2 (DIS)	440R-EM4R2 (EM)	440R-EM4R2D (EMD)	440R-S12R2 (SI)
MTTFd	164	355	484	190	165	262
Category	Up to 4					
Performance Level	Up to e					
DC avg	99%					
Mission Time	20 years					
Days of Operation	365 days					
Hours of Operation	24 hr					
T cycle	8 hr / 8.28 s					

A

add-on profile
Studio 5000 Logix Designer 60

adjustment
switch 36

agency certifications 93

AOP
Studio 5000 Logix Designer 60

application
examples 53
CI safety relay 53
DI safety relay 54
DIS safety relay 55
EM safety relay 56
EMD safety relay 57
SI safety relay 58

approvals
regulatory 93

assignments
terminal 18

automatic
reset 31

auxiliary output 29, 83
issues 83
specifications 92

B

B1 input
specifications 91

C

capacitance effect 71

category 94

certifications
agency 93

channel simultaneity 73

check
power supply 65
safety device input 66
safety output 78
single wire safety circuit 74
voltage 65

CI safety relay
overview 10

circuit block diagram 51, 52

communication
Ethernet 59

compliance
European Union (EU) directives 93

configuration 35
process 38

connect
power supply 20

considerations
enclosure 14

contact

resistance 84
voltage-free 67

cycling
multiple-channel 73

D

date code
manufacturing 88

detect
off pulse 71

devices
mechanical contacts 20
safety, OSSD output 22

DI safety relay
overview 10
safety mat 55
switch adjustment 36

diagnostics
indicators 42

diagram
internal circuit block 51
CI safety relay 51
DI safety relay 51
DIS safety relay 51
EM safety relay 52
EMD safety relay 52
SI safety relay 52

dimensions
mounting 13

DIN rail 13
mounting 13
removal 13

directive
EMC 93
European Union 93
machine safety 93

DIS safety relay
overview 10
switch adjustment 36

discrepancy 73

E

effect
OSSD test pulse 70

electromechanical
output 26
electromechanical output
issues 78

EM safety relay
overview 11

EMC
directive 93

EMD safety relay
overview 11
switch adjustment 37
timing functions 45

enclosure

- considerations 14

environmental

- specifications 89

Ethernet

- communication 59

European Union (EU) directives

- compliance 93

examples

- application 53

- CI safety relay 53

- DI safety relay 54

- DIS safety relay 55

- EM safety relay 56

- EMD safety relay 57

- SI safety relay 58

- wiring 53

- CI safety relay 53

- DI safety relay 54

- DIS safety relay 55

- EM safety relay 56

- EMD safety relay 57

- SI safety relay 58

excessive heat

- prevent 15

expansion relays

- monitor 32

F**features**

- hardware 9

functions

- pulse testing 43

G**general**

- specifications 89

ground 17, 66

- relay 19

Guardmaster safety relay

- CI 10, 51, 53

- DI 10, 36, 51, 54

- DIS 10, 36, 51, 55

- EM 11, 52, 56

- EMD 11, 37, 45, 52, 57

- SI 11, 52, 58

H**hardware**

- features 9

heat

- prevent excessive 15

I**indicator**

- PWR/fault 63

- flashing red 64

- green with flashing red 65

- solid red 63

indicators

- diagnostics 42

- normal operation 41

- powerup 41

- status 41

input

- jog 33

- monitor 29

- pulse testing 43

- CI safety relay 43

- DI, DIS, and SI safety relay 44

- reset 29

- retriggerable 33

- safety 20

- single wire safety 28

- SWS 28

installation 13**internal circuit block**

- diagram 51

- CI safety relay 51

- DI safety relay 51

- DIS safety relay 51

- EM safety relay 52

- EMD safety relay 52

- SI safety relay 52

J**jog** 48

- input 33

L**label**

- product (current) 88

- product (old) 88

long wire 72**M****machine safety**

- directive 93

manual

- reset 31

manufacturing date code 88**mats**

- safety 23

mechanical contacts

- devices 20

monitor

- expansion relays 32

- input 29

monitored reset 31

mounting

- dimensions 13
- DIN rail 13

multiple-channel

- cycling 73

multi-position

- switch 10

N**non-retriggerable**

- off delay 45

normal operation

- indicators 41

O**off delay**

- non-retriggerable 45
- retriggerable 46

off pulse

- detect 71

on delay 47**optical communication bus 10****OSSD output 26**

- issues 79
- safety devices 22

OSSD outputs

- pulse testing 44

OSSD test pulse

- effect 70

output

- auxiliary 29, 83
 - issues 83
- electromechanical 26
- OSSD 26
- safety 25
- single wire safety 28
- SWS 28
- X32 85

overview 9

- CI safety relay 10
- DI safety relay 10
- DIS safety relay 10
- EMD safety relay 11
- EMD safety relay 11
- SI safety relay 11

P**performance level 94****power 17****power supply**

- check 65
- connect 20
- ground 66

powerup

- indicators 41

prevent

- excessive heat 15

process

- configuration 38

product label

- current 88
- old 88

pulse testing

- functions 43
- input 43
 - CI safety relay 43
 - DI, DIS, and SI safety relay 44
- OSSD outputs 44

PWR/fault status indicator 63

- flashing red 64
- green with flashing red 65
- solid red 63

R**rating**

- SIL 94

recommendation

- wiring 17

recovery time 74**regulatory approvals 93****relay**

- ground 19

removable

- terminals 14
- terminal blocks 9

removal 13

- terminal block 87

replacement

- terminal block 87

requirements

- wiring 17

terminals

- removable 14

reset

- automatic 31
- input 29
- input, specifications 90
- manual 31
- monitored 31

resistance

- contact 84

resistance effect 72**retriggerable**

- input 33
- off delay 46

S**safety**

- input 20
- mats 23
- output 25

safety device input

- check 66

safety inputs IN, IN1, and IN2

- specifications 90

- safety mat**
 - DI safety relay 55
 - safety output**
 - check 78
 - electromechanical output
 - issues 78
 - OSSD output
 - issues 79
 - safety outputs**
 - specifications 91
 - safety relay**
 - CI 10, 51, 53
 - DI 10, 36, 51, 54
 - DIS 10, 36, 51, 55
 - EM 11, 52, 56
 - EMD 11, 37, 45, 52, 57
 - SI 11, 52, 58
 - series** 88
 - SI safety relay**
 - overview 11
 - SIL**
 - rating 94
 - simultaneity**
 - channel 73
 - single wire safety**
 - input 28
 - output 28
 - specifications 92
 - single wire safety circuit**
 - check 74
 - spacing** 14
 - specifications** 89
 - auxiliary output 92
 - B1 input 91
 - environmental 89
 - general 89
 - reset input 90
 - safety inputs IN, IN1, and IN2 90
 - safety outputs 91
 - single wire safety 92
 - SWS 92
 - status indicator**
 - PWR/fault 63
 - flashing red 64
 - green with flashing red 65
 - solid red 63
 - status indicators** 9, 41
 - diagnostics 42
 - normal operation 41
 - powerup 41
 - steps**
 - troubleshooting 62
 - Studio 5000 Logix Designer**
 - add-on profile (AOP) 60
 - suppressors**
 - surge 27
 - surge suppressors** 27
 - switch**
 - adjustment 36
 - DI safety relay 36
 - DIS safety relays 36
 - EMD safety relay 37
 - multi-position 10
 - SWS**
 - input 28
 - output 28
 - specifications 92
 - SWS circuit**
 - check 74
- T**
- terminal**
 - assignments 18
 - torque 17
 - terminal block**
 - removal 87
 - replacement 87
 - terminal blocks**
 - removable 9
 - time**
 - recovery 74
 - timing functions**
 - EMD safety relay 45
 - tools** 61
 - torque**
 - terminal 17
 - troubleshooting** 41
 - steps 62
- V**
- version** 88
 - voltage**
 - check 65
 - voltage-free contact** 67
- W**
- web page** 60
 - wire** 17
 - size 17
 - wiring**
 - examples 53
 - CI safety relay 53
 - DI safety relay 54
 - DIS safety relay 55
 - EM safety relay 56
 - EMD safety relay 57
 - SI safety relay 58
 - recommendation 17
 - requirements 17
- X**
- X32 output** 85

Rockwell Automation Support

Use the following resources to access support information.

Technical Support Center	Knowledgebase Articles, How-to Videos, FAQs, Chat, User Forums, and Product Notification Updates.	https://rockwellautomation.custhelp.com/
Local Technical Support Phone Numbers	Locate the phone number for your country.	http://www.rockwellautomation.com/global/support/get-support-now.page
Direct Dial Codes	Find the Direct Dial Code for your product. Use the code to route your call directly to a technical support engineer.	http://www.rockwellautomation.com/global/support/direct-dial.page
Literature Library	Installation Instructions, Manuals, Brochures, and Technical Data.	http://www.rockwellautomation.com/global/literature-library/overview.page
Product Compatibility and Download Center (PCDC)	Get help determining how products interact, check features and capabilities, and find associated firmware.	http://www.rockwellautomation.com/global/support/pcdc.page

Documentation Feedback

Your comments will help us serve your documentation needs better. If you have any suggestions on how to improve this document, complete the How Are We Doing? form at http://literature.rockwellautomation.com/idc/groups/literature/documents/du/ra-du002_-en-e.pdf.

Rockwell Automation maintains current product environmental information on its website at <http://www.rockwellautomation.com/rockwellautomation/about-us/sustainability-ethics/product-environmental-compliance.page>.

Allen-Bradley, Atlas, Cadet, Elf, Ferrogard, Guardmaster, GuardShield, Kinetix, Lifeline, PowerFlex, Rockwell Automation, Rockwell Software, Rotacam, Safedge, SafeZone, SensaGuard, Sipa, Studio 5000 Logix Designer, and Trojan are trademarks of Rockwell Automation, Inc.

EtherNet/IP is a trademark of ODVA, Inc.

Rockwell Otomasyon Ticaret A.Ş., Kar Plaza İş Merkezi E Blok Kat:6 34752 İçerenköy, İstanbul, Tel: +90 (216) 5698400

www.rockwellautomation.com

Power, Control and Information Solutions Headquarters

Americas: Rockwell Automation, 1201 South Second Street, Milwaukee, WI 53204-2496 USA, Tel: (1) 414.382.2000, Fax: (1) 414.382.4444

Europe/Middle East/Africa: Rockwell Automation NV, Pegasus Park, De Kleetlaan 12a, 1831 Diegem, Belgium, Tel: (32) 2 663 0600, Fax: (32) 2 663 0640

Asia Pacific: Rockwell Automation, Level 14, Core F, Cyberport 3, 100 Cyberport Road, Hong Kong, Tel: (852) 2887 4788, Fax: (852) 2508 1846

Publication 440R-UM013E-EN-P – March 2017

Supersedes Publication 440R-UM013D-EN-P – December 2016

Copyright © 2017 Rockwell Automation, Inc. All rights reserved. Printed in the U.S.A.