



Guardmaster DG Safety Relay and GuardLink System

Catalog Numbers 440R-DG2R2T (DG Safety Relay); 440S-SF8D, 440S-SF5D, 440S-MF5D, 440S-MF8D (Taps); 898D-418U-DM2 (Terminator); 440S-GLTAPBRKx (Bracket); 440R-ENETR (EtherNet/IP Network Interface)



Important User Information

Read this document and the documents listed in the additional resources section about installation, configuration, and operation of this equipment before you install, configure, operate, or maintain this product. Users are required to familiarize themselves with installation and wiring instructions in addition to requirements of all applicable codes, laws, and standards.

Activities including installation, adjustments, putting into service, use, assembly, disassembly, and maintenance are required to be carried out by suitably trained personnel in accordance with applicable code of practice.

If this equipment is used in a manner not specified by the manufacturer, the protection provided by the equipment may be impaired.

In no event will Rockwell Automation, Inc. be responsible or liable for indirect or consequential damages resulting from the use or application of this equipment.

The examples and diagrams in this manual are included solely for illustrative purposes. Because of the many variables and requirements associated with any particular installation, Rockwell Automation, Inc. cannot assume responsibility or liability for actual use based on the examples and diagrams.

No patent liability is assumed by Rockwell Automation, Inc. with respect to use of information, circuits, equipment, or software described in this manual.

Reproduction of the contents of this manual, in whole or in part, without written permission of Rockwell Automation, Inc., is prohibited

Throughout this manual, when necessary, we use notes to make you aware of safety considerations.



WARNING: Identifies information about practices or circumstances that can cause an explosion in a hazardous environment, which may lead to personal injury or death, property damage, or economic loss.



ATTENTION: Identifies information about practices or circumstances that can lead to personal injury or death, property damage, or economic loss. Attentions help you identify a hazard, avoid a hazard, and recognize the consequence.

IMPORTANT Identifies information that is critical for successful application and understanding of the product.

Labels may also be on or inside the equipment to provide specific precautions.



SHOCK HAZARD: Labels may be on or inside the equipment, for example, a drive or motor, to alert people that dangerous voltage may be present.



BURN HAZARD: Labels may be on or inside the equipment, for example, a drive or motor, to alert people that surfaces may reach dangerous temperatures.



ARC FLASH HAZARD: Labels may be on or inside the equipment, for example, a motor control center, to alert people to potential Arc Flash. Arc Flash will cause severe injury or death. Wear proper Personal Protective Equipment (PPE). Follow ALL Regulatory requirements for safe work practices and for Personal Protective Equipment (PPE).

	Preface	
	Who Should Use This Manual	7
	Summary of Changes	7
	Definitions	8
	Additional Resources	9
	Chapter 1	
Overview	What Is a GuardLink System?	11
	Taps	12
	DG Safety Relay	13
	Safety Device Inputs	13
	Single Wire Safety (SWS) Input	13
	Output Monitoring	13
	Reset	14
	GuardLink Principle of Operation	15
	GuardLink State	15
	GuardLink Transition from Safe State to Operational State ...	17
	GuardLink Transition from Operational State to Safe State ...	17
	GuardLink Fault Reset Command	17
	OSSD Tap	18
	EMSS Tap	18
	Guard Locking with GuardLink Systems	18
	Guard Locking Application Example	19
	Chapter 2	
GuardLink System Design	System Current Calculation	24
	Voltage Drop Consideration	25
	Tap Cabling	28
	Terminator	29
	Tap Replacement	29
	Response Time	29
	Chapter 3	
Installation	Mounting Dimensions	31
	DIN Rail Mounting and Removal	32
	Removal	32
	Spacing	32
	Terminal Block Removal and Replacement	33
	Terminal Block Removal	33
	Terminal Block Replacement	33
	Tap Installation	34
	Enclosure Considerations	35
	DG Safety Relay	35
	Taps	35
	Prevent Excessive Heat	36
	DG Safety Relay	36
	Taps	36

Power, Ground, and Wire	Chapter 4	
	Wiring Requirements and Recommendation	37
	DG Safety Relay	37
	Wire Size	37
	Terminal Torque	37
	Terminal Assignment and Function	38
	Tap Pin Assignment and Function	39
	Power Supply Connection	41
	DG Safety Relay	41
	Taps	42
	Multiple Power Supplies	43
	DG Safety Relay Input Wiring	43
	GuardLink Connections	43
	Devices with OSSD Outputs	44
	Voltage-free Contacts	44
	Single Wire Safety	45
	SWS Connections	45
	Safety Output Wiring	46
	13/14 and 23/24 Safety Outputs	46
	Surge Protection	47
Configuration	Chapter 5	
	Config/Set Push Button	49
	Run Mode	49
	Configuration Mode	50
	Sel./Save Push Button	50
	Run Mode	50
	Configuration Mode	50
	Reset	50
	Configuration Steps	50
	Delay Setting	53
	Verification	53
	Push Buttons on the Front of DG Safety Relay	54
	AOP in the Studio 5000 Environment	54
Status Indicators	Chapter 6	
	DG Safety Relay Status Indicators	55
	Tap Status Indicators	56
Pulse Testing Functions	Chapter 7	
	Pulse Testing for Inputs	57
	EMSS SmartTap Pulse Tests	58
Opto-link Communications	Chapter 8	
	Optical Bus	59
	Arrangement with 440R-ENETR Interface	60

	Chapter 9	
Safety Function Calculations	GuardLink System	61
	SISTEMA	63
	Appendix A	
Specifications	DG Safety Relay.....	65
	Tap	68
	Appendix B	
Configuration Examples	Configuration 1.....	72
	Configuration 2.....	74
	Configuration 3.....	76
	Configuration 4.....	77
	Configuration 5.....	78
	Configuration 6.....	79
	Configuration 7.....	80
	Configuration 8.....	81
	Configuration 9.....	82
	Configuration 10.....	83
	Configuration 11.....	84
	Configuration 12.....	85
	Configuration 13.....	86
	Configuration 14.....	87
	Configuration 15.....	88
	Configuration 16.....	89
	Configuration 17.....	90
	Configuration 18.....	91
	Configuration 19.....	92
	Configuration 20.....	93
	Appendix C	
Regulatory Approvals	Agency Certifications.....	95
	Waste Electrical and Electronic Equipment (WEEE).....	95
	Compliance to European Union Directives.....	95
	Machine Safety Directive.....	95
	DG Safety Relay Ratings	96
	SIL Rating	96
	Performance Level/Category	96
	Tap Ratings.....	97
	SIL Rating	97
	Performance Level/Category	98
	EMC Directive.....	98
	Declaration of Conformity.....	99

DG Safety Relay Indicator Fault Codes	Appendix D	
	Determine a Fault	101
	Clear a Fault	101
	Index	105

This user manual is a reference guide for the GuardLink™ safety system, plug-in modules, and accessories. It describes the procedures that you use to install, wire, and troubleshoot your relay. This manual explains how to install and wire your relay and gives you an overview of the GuardLink safety system

Who Should Use This Manual

Use this manual if you are responsible for the design, installation, programming, or troubleshooting of control systems that use the GuardLink safety system.

You must have a basic understanding of electrical circuitry and familiarity with safety-related control systems. If you do not, obtain the proper training before using this product.

Summary of Changes

This manual contains new and updated information as indicated in the following table.

Topic	Page
Updated GuardLink Fault Reset Command section.	17
Updated Voltage Drop Consideration section.	25
Updated values in Table 4 and Table 5 .	26 and 27
Added troubleshooting tip to Terminator section and updated Tap Replacement section.	29
Added mating cordset wire colors in Figure 22 . . . Figure 25 .	39 and 40
Added Surge Suppressor Recommendations (Table 8).	47
Updated Important note to clarify how to abort a configuration.	52
Updated the PWR/Fault, IN 1, OUT X, Reset, and FB indicator descriptions (Table 12).	55
Updated Arrangement with 440R-ENETR Interface section.	60
Added wiring connections to terminals A1 and A2 of EM safety relay in Configuration 1 . . . Configuration 10.	72 . . . 83
Added decimal values to the configuration examples in Appendix B .	71 . . . 93
Added Performance Level/Category section for taps.	98
Added a Declaration of Conformity section.	99
Added DG Safety Relay Indicator Fault Codes appendix.	101







Definitions

Publication [AG-7.1](#) contains a glossary of terms and abbreviations that are used by Rockwell Automation to describe industrial automation systems. The following is a list of specific terms and abbreviations that are used in this manual.

- **Electrical Mechanical Safety Switch (EMSS)** - A type of tap that interfaces with safety devices that have redundant voltage-free contacts. The tap generates pulse tests to detect short circuits to the DC power supply, short circuits to the DC common, and shorts circuits between the two contacts.
- **GuardLink Control, Lock, and Unlock (CLU) Signal** - This signal is either static or dynamic. When static, this signal is LO when the system is operational and HI when a demand is placed on the safety system. The signal is dynamic when an unlock command is issued to Power to Release guard locking devices.
- **GuardLink Operational State** - All taps on the GuardLink circuit indicate that their associated safety device is ready for the machine to operate.
- **GuardLink Safe State** - One or more of the taps on the GuardLink circuit indicate that their associated safety device is not ready for the machine to operate.
- **GuardLink Safety Signal** - A known dynamic safety signal in operational mode and a two-way communication signal that the DG safety relay initiates to determine the status of the taps in the safe state.
- **HI** - The ON state of the output of a logic block or the state of an input to a logic block or a voltage level to be above the turn-on threshold.
- **LO** - Logic state of being OFF or a voltage level to be below the turn-off threshold.
- **N/C** - No connection
- **N.C. (Normally Closed)** - A voltage-free electrical contact whose normal state (that is, no pressure or electrical potential applied) is in the closed position.
- **N.O. (Normally Open)** - A voltage-free electrical contact whose normal state (that is, no pressure or electrical potential applied) is in the open position.
- **Output Signal Switching Device (OSSD)** - Generally a pair of solid-state signals that are pulled up to the DC source supply. The signals are pulse-tested for short circuits to the DC power supply, short circuits to the DC common and shorts circuits between the two signals.
- **Reaction Time** - The time between the true states of one input to the ON state of the output.
- **Recovery Time** - The time that is required for the input to be in the LO state before returning to the HI state.
- **Response Time** - The time between the trigger of one input to the OFF state of the output.
- **Safety Function** - The complete process from sensing the action (for example, open a safety gate) to executing the final output device (for example, turning off a pair of contactors).

- **Single Wire Safety (SWS)** - A unique unidirectional safety-rated signal that is sent over one wire to indicate a safety status and command the initiation of a safety function. The SWS can be used in Category 4, Performance Level e, per ISO 13849-1 and safety integrity level (SIL) 3, per IEC 62061 and IEC 61508.
- **Status Indicators** - The status indicators on the front face of the DG safety relay and the taps are bicolor. [Table 1](#) shows how the status indicators are used in this publication.

Table 1 - Status Indicator State

Symbol	Description	Symbol	Description
	Green indicator is OFF Red indicator is OFF		Green indicator flashes with certain frequency Red indicator is OFF
	Green indicator is OFF Red indicator is ON		Green indicator is ON Red indicator is ON
	Green indicator is OFF Red indicator flashes with certain frequency		Green indicator flashes with certain frequency Red indicator flashes with certain frequency
	Green indicator is ON Red indicator is OFF		

- **Tap** - A connection in a GuardLink circuit that associates a safety device to the GuardLink circuit.
- **Voltage-free Contacts** - Electrical contacts that have no voltage that is applied to them. These contacts are typically N.O. or N.C. contacts that change state due to a mechanical (for example, someone pressing a push button) or electromechanical (for example, solenoid operated) stimulus.

Additional Resources

These documents contain additional information concerning related products from Rockwell Automation.

Resource	Description
NEMA Standard 250 and IEC 60529	Provides explanations of the degrees of protection that is provided by different types of enclosure.
Guardmaster EtherNet/IP Network Interface User Manual, publication 440R-UM009	A detailed description of module functionality, configuration, installation procedure and information on how to use the Guardmaster EtherNet/IP Network Interface (440R-ENETR).
Industrial Automation Wiring and Grounding Guidelines, publication 1770-4.1	Provides general guidelines for installing a Rockwell Automation industrial system.
Product Certifications website, http://www.rockwellautomation.com/global/certification/overview.page	Provides declarations of conformity, certificates, and other certification details.
Industrial Automation Glossary, publication AG-7.1	A glossary of industrial automation terms and abbreviations.

You can view or download publications at <http://www.rockwellautomation.com/global/literature-library/overview.page>. To order paper copies of technical documentation, contact your local Allen-Bradley distributor or Rockwell Automation sales representative.

Notes:

Overview

What Is a GuardLink System?

A GuardLink system is a collection of components to simplify a series connection of safety devices while achieving the highest industrial safety rating. The system has these important features:

- Simplifies the connection of series connected safety devices.
- Facilitates the scalability of the safety series connections.
- Provides diagnostic information about each device in the system without having to run a separate status wire back to the machine control system.
- Allows the simultaneous or individual lock and unlock of guard locking interlocks in the series connected system. No need for an additional wire from the machine control system to lock and unlock the safety gate.
- Helps ease communication to the machine control system over EtherNet/IP. Communication includes sending non-safety commands to the devices and receiving status information back from the safety devices.

[Figure 1 on page 12](#) shows the basic components of a typical application. The GuardLink tap has M12 quick disconnect terminations to facilitate wiring with cordsets and patchcords. The DG safety relay can accommodate one or two GuardLink circuits or a combination of GuardLink and individual safety devices.

Each GuardLink circuit can accommodate up to 32 taps. The DG safety relay operates and monitors two safety contactors and has a monitored manual reset.

A typical GuardLink system consists of the following:

- One DG (dual GuardLink) Guardmaster® safety relay (GSR)
- One GuardLink SmartTap for each safety device
- One terminator for each GuardLink circuit
- Patchcords and cordsets
- An optional Ethernet interface

Figure 1 - Typical GuardLink System

Each DG safety relay can accommodate up to two GuardLink circuits, each containing up to 32 devices.

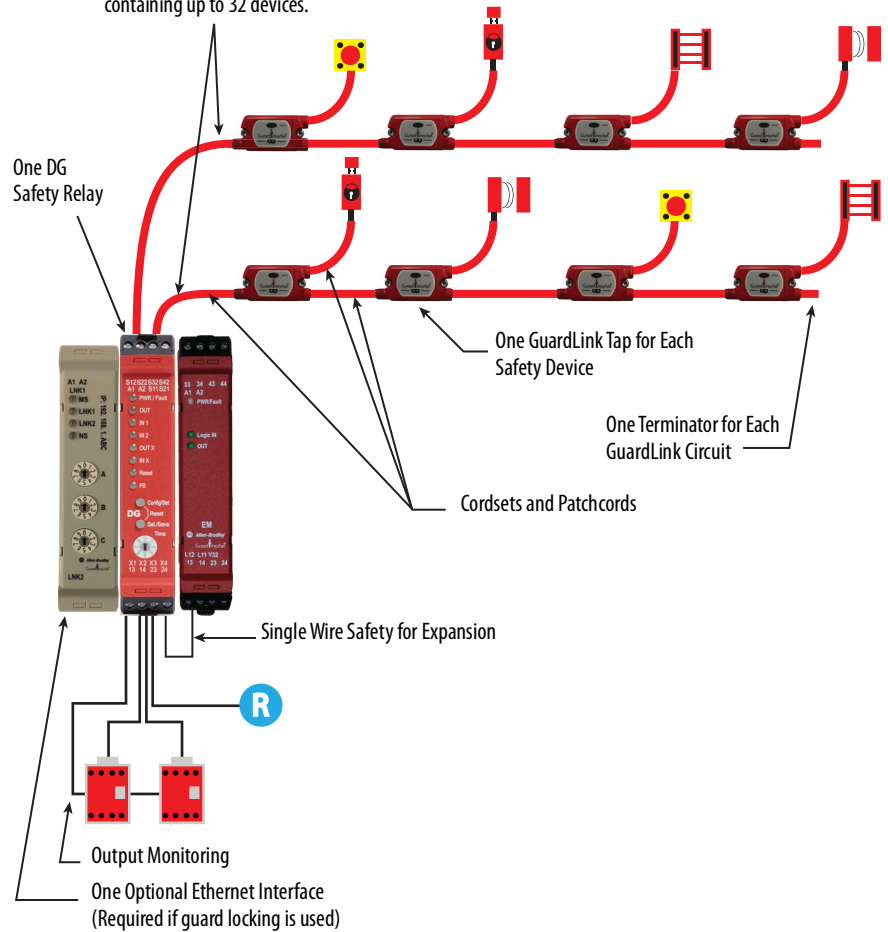

Taps

Taps create nodes in the GuardLink circuit. A safety device is connected to each tap. Two types of taps are available:

- Taps that interface with devices having voltage-free safety contacts
- Taps that interface with devices that have OSSD signals

Each type is available in an 8-pin and 5-pin device connection version.

The taps are intended to be mounted on the machine, near the location of the device it monitors. The different types and versions can be connected in any order and can be mixed.

DG Safety Relay

The DG safety relay is the host of the GuardLink system. By using a sequence of push buttons on the front face, the DG safety relay can be configured for many types of safety applications. The DG safety relay can do the following:

- Monitor up to two GuardLink circuits, two safety devices or a combination
- Use Single Wire Safety (SWS) input and output for expansion
- Execute Stop Categories 0 or 1 (immediate and delayed outputs)
- Monitor the status of output safety devices, like contactors
- Be configured for automatic or monitored manual reset
- Be configured to initiate a lock function for guard locking with a GuardLink circuit
- Be configured to initiate an unlock function for guard locking with a GuardLink circuit

Safety Device Inputs

The DG safety device inputs can be configured in one of the following arrangements:

- One GuardLink circuit
- Two GuardLink circuits
- One GuardLink circuit and one safety device
- Two safety devices
- One safety device

The DG safety relay applies AND logic to all used inputs. Unused inputs are ignored.

Single Wire Safety (SWS) Input

The DG safety relay then applies AND logic to the SWS input if configured for use. The single wire safety input is ignored if not included in the configuration.

Output Monitoring

The DG safety relay monitors the status of external safety output devices. After all safety inputs are satisfied, the DG safety relay checks the monitoring input terminal. If 24V is present, the DG safety relay proceeds to execute the reset function.

Reset

The DG safety relay reset function can be applied one of three ways:

- Automatic reset (no connection needed)
- Monitored manual reset by a momentary push button that is connected to an input terminal
- With an Ethernet interface, the machine control system can initiate the reset function.

The DG safety relay allows both an input terminal and the machine control system to perform the monitored manual reset function. The reset signal must transition from LO to HI and back to LO within a window of 0.25...3 seconds. The reset occurs on the trailing edge. When using a programmable logic controller (PLC) to generate the reset signal, use a narrower window (0.26...2.99 s) for more reliable reset action.



ATTENTION: The reset function must not be used to start or restart the machine.

In [Figure 2](#), the DG safety relay has one GuardLink circuit and one safety device input. The EtherNet/IP interface reports status information to the machine control system. The DG safety relay monitors the status of the two output contactors and uses monitored manual reset to energize the contactors.

Figure 2 - One GuardLink Circuit and One Safety Device

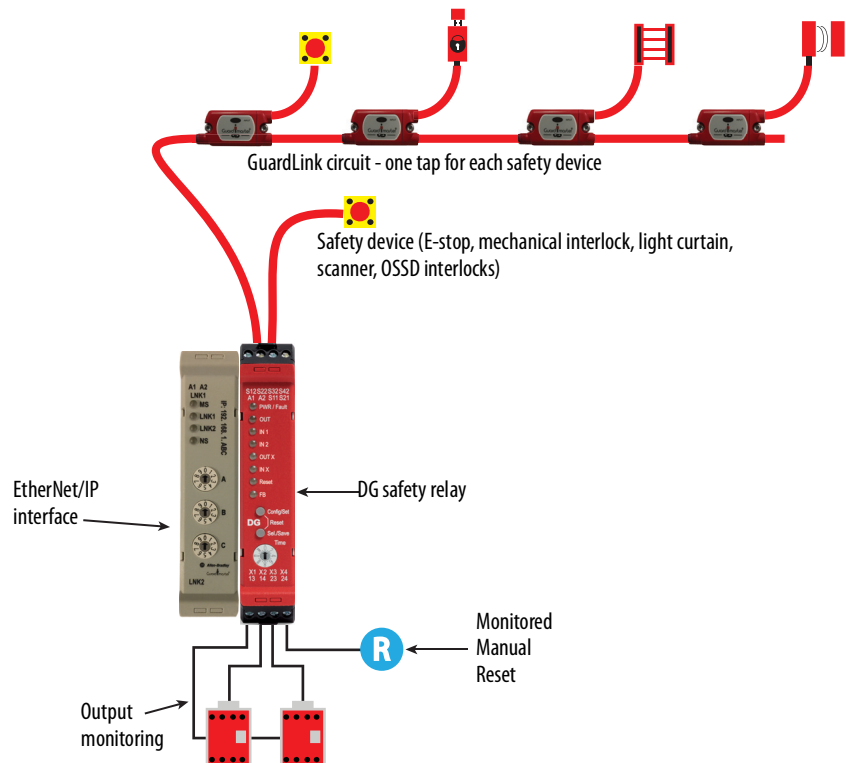
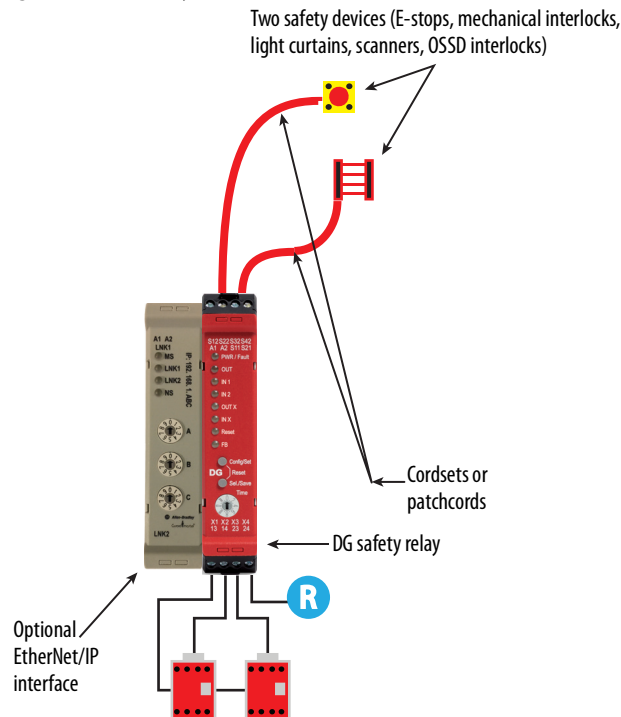

Figure 3 shows an example of a DG safety relay operating as the equivalent of a DI safety relay. In Figure 3, the DG safety relay is configured to accept two input devices, control and monitor two contactors with a manual reset input. The 440R-ENETR interface reports the status to the machine control system. The machine control system can also initiate a reset command.

Figure 3 - Two Safety Devices



GuardLink Principle of Operation

The GuardLink circuit is a continuous chain of safety devices that are connected in series with only four wires. Two wires provide power and ground to the taps and devices.

The third wire (GuardLink Safety Signal) performs the diagnostics on the taps and the devices that are connected to each tap while in the safe state. It also carries the dynamic safety signal while in an operational state.

The fourth wire (CLU) provides the lock/unlock commands to guard locking devices on the circuit.

GuardLink State

The GuardLink chain can be in one of four states:

- Initialization
- Safe
- Operational
- Fault

Initialization State

The initialization state starts when power is applied to the GuardLink circuit and ends when the GuardLink circuit enters the safe state. If no errors exist, the GuardLink circuit transitions to the safe state; the initialization state cannot transition to the operational state.

During initialization, the DG safety relay establishes and verifies the validity of the circuit by checking the following items:

- All devices set their node number
- Not more than 32 devices exist
- The firmware of the taps is compatible with the DG safety relay firmware.
- The DG safety relay detects node type and position automatically. When a 440R-ENETR interface is used, it acquires the node types and positions from the DG safety relay. The 440R-ENETR interface validates the correct type and position against the setup that is provided by the Studio 5000® Add-On-Profile (AOP). If validation is not successful, the 440R-ENETR interface reports an error.
- Validates a terminator is attached to the GuardLink circuit.

Safe State

The GuardLink safety signal commands the DG safety relay to a safe state, which turns all safety outputs OFF. The GuardLink safety signal monitors the circuit for changes of state from the taps.

The CLU signal is HI (if guard locking devices are not used) or sending a dynamic unlock signal (if guard locking devices are used). The taps indicate this state by a solid red Link indicator.

Operational State

The GuardLink operational state is described as the GuardLink safety signal that generates a specific dynamic signal to the DG safety relay and the CLU signal being LO. The state of the DG safety relay safety outputs can be OFF or ON. The state depends on the configuration, other safety device inputs, the feedback monitoring input, and the reset input.

Fault State

The DG safety relay and the taps have two fault states: recoverable and non-recoverable. When a fault occurs, the taps and DG safety relay are in a safe state. Diagnostic information is provided by the indicators. The DG safety relay also sends diagnostic information to the EtherNet/IP interface.

Recoverable faults can be cleared by cycling the faulted input devices. Non-recoverable faults require the power to the cycled and can also require troubleshooting and correction of the fault. When an EtherNet/IP interface is used, the machine control system can issue a fault reset (equivalent to a power cycle).

GuardLink Transition from Safe State to Operational State

When the GuardLink signal is in the safe state, the DG safety relay holds the CLU signal in the high or dynamic unlocking state. The DG safety relay puts all taps in the safe state. For the GuardLink signal to return to the operational state, the DG safety relay must know that all taps are ready to go to the operational state. If the taps are ready to go, the CLU signal is set to LO.

Now that the CLU is set to LO, the last tap generates the safety signal. Each successive upstream device verifies that the previous device is in a safe state, confirms that its own device is in a safe state, and sends an inverted safe state signal to the next device.

When the DG safety relay receives the safety signal, the GuardLink circuit is in an operational state, and the DG safety relay continues with the evaluation of the other inputs, output monitoring, and reset inputs.

GuardLink Transition from Operational State to Safe State

Once an input device has a demand on its safety function, the tap stops sending the safety signal. When the DG safety relay no longer detects the safety signal, the CLU signal is set to HI to make all taps enter the safe state.

GuardLink Fault Reset Command

Devices with OSSD outputs can sometimes go to a fault state that requires power cycling. The Ethernet interface can be used to send a fault reset signal from the machine control system to individual devices. This reset signal cycles the power to the device connected to the specified tap.

OSSD Tap

The OSSD tap is designed to specifically interface with safety products that generate OSSD outputs. The OSSD tap does not perform testing on the OSSD signals as the input device must perform the test.

The OSSD tap is looking to see if the outputs of the connected device are energized or de-energized. If the outputs are de-energized, then the tap goes to a safe state, and the input indicator is red. If the outputs of the device are energized, then the tap shows a solid or flashing green input indicator.

If the OSSD tap inputs are not the same state for three or more seconds, then the tap enters a recoverable fault state. Both inputs must go to LO and then back to HI to recover.

EMSS Tap

The EMSS tap is designed to interface with two voltage-free contacts. The tap applies 24V to one side of the contact on both channels and looks for the 24V on the monitoring input. These contacts are pulse tested by the tap, see [Pulse Testing Functions on page 57](#) for pulse details.

The tap is looking to see if both contacts are closed or open. When the contacts open, the tap goes to a safe state, and the input indicator is red. When the contacts close, the tap goes to an operational state, which turns the input indicator either solid or flashing green.

The EMSS tap has a 10 second simultaneity window. If one contact opens, the second contact must open within 10 seconds. Similarly, if one contact closes, the second contact must close within 10 seconds. If the simultaneity window requirement is not met, the tap goes to a recoverable fault state. To recover, both contacts must be cycled open and then closed again within 10 seconds.

Guard Locking with GuardLink Systems

Only Power-to-Release guard locking devices can be connected to the GuardLink taps. When guard locking devices are connected, a 440R-ENETR interface must be used. The lock and unlock commands can only be issued to the guard locking devices through the 440R-ENETR interface.

When an unlock request is issued, the DG safety relay turns off OUT X (terminal X2) immediately and starts the off-delay timer. When the off-delay timer expires, the DG safety relay issues an unlock command to the GuardLink circuit and turns off its safety outputs (terminals 13/14 and 23/24).

When multiple guard locking devices are installed on a GuardLink system, the DG safety relay inserts a short delay between commands to each successive device to minimize the momentary inrush current to the solenoids. The device closest to the DG safety relay receives the command first. The device furthest away from the DG safety relay receives the command last.

The delay between commands is between 135...300 ms. When a few guard locking devices are used, the delay is 135 ms. As more guard locking devices are included in the circuit, the delay increases. When 32 guard locking devices are used, the delay can be up to 300 ms between each device.

[Figure 4](#) shows an example timing diagram. The delay switch is set to position 5 (1 second delay). The first guard unlocking command starts at 1000 ms. The second unlock signal occurs at 1135 ms. The third unlock signal occurs at 1270 ms. If 32 guard locking devices are installed, the last one receives the unlock command at 10,600 ms.

Figure 4 - Unlock Command Timing Diagram

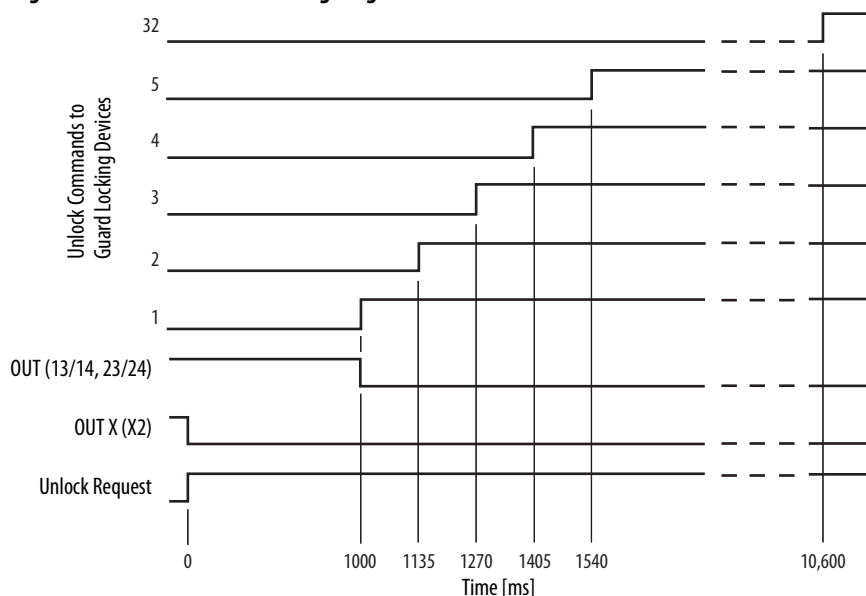

Guard Locking Application Example

[Figure 5 on page 20](#) shows a typical guard locking application example. The DG safety relay has four taps on the GuardLink circuit:

- First tap — SensaGuard™ integrated-latch interlock switch
- Second tap — 440G-LZ guard locking interlock switch
- Third tap — TLS –ZR guard locking switch
- Fourth tap — SensaGuard flat-pack interlock switch

The TIME switch on the DG safety relay is set to position 9, which provides a 5 second delay to allow the motor to coast to a full stop.

The SensaGuard switches allow immediate access to the machine. Additional risk reduction measures must be provided to prevent access to the hazards during the timing period.

Because guard locking is used, a 440R-ENETR interface must be included in the application. The unlock and lock control commands are initiated by an HMI and PLC. The PLC sends the command to the 440R-ENETR interface. Over the optical bus, the 440R-ENETR interface instructs the DG safety relay to generate the unlock and lock commands through the GuardLink circuit. The DG and EM safety relays report status information over the optical bus back to the PLC through the 440R-ENETR interface.

Figure 5 - Guard Locking Application Example Schematic and Logic

Schematic

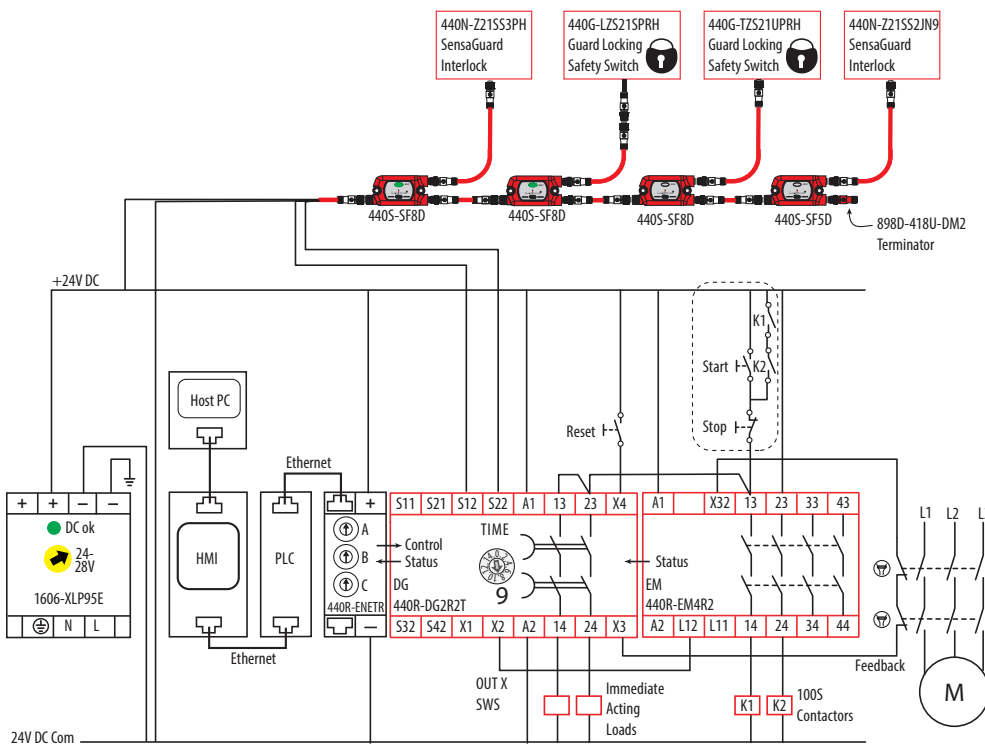

Logic

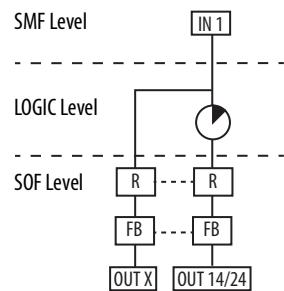

Table 2 - Guard Locking Application Example Configuration

Indicator	Function	Configuration ID: 0x6A	
OUT	Safety Functions	●	IN1
IN 1	Input Type	●	GuardLink
IN 2	Input Type	●	Not used
OUT X	Output Type	●	SWS
IN X	Input Mode	●	SWS Disabled
Reset	Reset Type	●	Monitored Manual
FB	Reset Assignment	●	SOF

- Circuit Status

The gates monitored by the SensaGuard interlock switches are closed. The guard locking switches are closed and locked. The DG and EM safety relays are OFF and ready for reset.

- Starting

Press the Reset button to energize the DG and EM safety relays. Their output contacts close. Press the Start button to start the motor via contactors K1 and K2 and energize the two immediate acting loads.

- Stopping

Press the Stop button to turn the motor and immediate acting loads off. The immediate acting loads and contactors K1 and K2 de-energize immediately, and the motor coasts to a stop. This action does not unlock the guard locking switches.

IMPORTANT The Start/Stop circuit can be replaced by an equivalent machine controlled system to start or restart the hazards after the safety system is reset.

- SensaGuard Switches

Opening either SensaGuard interlock turns off the DG and EM safety relays. The EM safety relay turns off K1 and K2 immediately, and the motor coasts to a stop. With the Time switch on the DG safety relay set to 9, the 13/14 and 23/24 outputs on the DG safety relay turn off after 5 seconds. This action does not unlock the guard locking switches.

- Unlock the Guard Locking Switches

Use the HMI to unlock the guard locking switches. The EM safety relay turns off K1 and K2 immediately, and the motor coasts to a stop. After 5 seconds, both the 13/14 and 23/24 outputs of the DG safety relay turn off the immediate acting loads and the guard locking switches are unlocked.

IMPORTANT The outputs of the DG safety relay (13/14 and 23/24) turn off and the unlock command occurs after the time delay expires. The immediate acting loads must remove the hazards they control quickly before you can open the gate and reach the hazard.

- Restart

Close the safety gates. If the gates were unlocked, use the HMI to initiate a lock command. Both gates are locked and the GuardLink circuit is satisfied. Press the Reset button. Press the Start button to energize the immediate acting loads and turn on the motor.

Notes:

GuardLink System Design

The design of a GuardLink circuit requires knowledge of the power requirements of the input devices and the length of the link cables. A voltage drop occurs across each tap. The cumulative voltage drop determines the number of taps that can be included in the circuit.

The GuardLink system makes it easy to monitor multiple devices over long distances when multiple access points to the hazardous area are required.

The DG safety relay monitors the GuardLink system. The GuardLink system can provide diagnostic information on each access point back to the machine control system.

The GuardLink system must be designed considering these factors:

- Voltage available at each node
- Current flowing through each node
- Cable lengths
- Wire size
- Power requirements for each tap
- Safety device power requirements

The GuardLink system is designed to operate on a 24V DC system. The maximum continuous current on the link circuit must not exceed 4 A; the taps and link cables are rated for 4 A continuous.

[Figure 6 on page 24](#) identifies three tap connections: T1, T2, and T3. The voltage and safety signals are sourced to connection J1. J2 is connected to downstream taps. J3 of each tap is connected to a safety device.

Figure 6 - Tap Connections

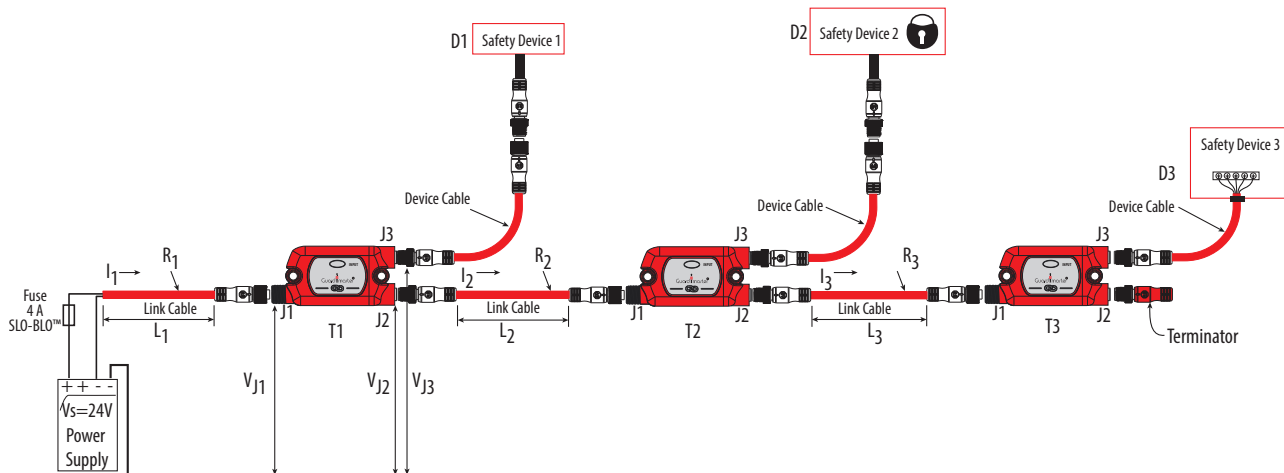

Table 3 - Key for Figure 6

Item	Description
D1, D2, D3	Safety devices
I_1, I_2, I_3	Current in the link cable (A)
I_{T1}, I_{T2}, I_{T3}	Current required by a tap (A)
I_{D1}, I_{D2}, I_{D3}	Current required by a safety device (A)
L_1, L_2, L_3	Length of link cable (m)
R_1, R_2, R_3	Resistance of wire (Ω)
T1, T2, T3	Taps
V_{J1}, V_{J2}, V_{J3}	Voltage at tap connector (V)

System Current Calculation

The GuardLink circuit current must be calculated to determine whether a significant voltage drop occurs to a safety device.

The total system current, I_1 , is the sum of the current required by the first tap plus the current required by the device that is connected to the first tap plus the current required by the downstream circuit. The total system current must not exceed 4 A, continuous.

$$I_1 = I_{T1} + I_{D1} + I_2$$

The current in each segment of the GuardLink circuit is calculated in a similar fashion.

$$I_2 = I_{T2} + I_{D2} + I_3$$

$$I_3 = I_{T3} + I_{D3}$$

The total system current, I_1 , is therefore the sum of the device currents plus the sum of the tap currents.

$$I_1 = \sum I_T + \sum I_D$$

Voltage Drop Consideration

With the potential of using up to 32 taps and long cable lengths between taps, the voltage available to the safety devices at connector J3 must be calculated.

The voltage available to the safety device has two components:

- The voltage drop due to the wire resistance of the cables
- The voltage drop within the tap

The resistance of the recommended 18 AWG cordsets and patchcords is (0.02095 ohms/m (0.00664 ohms/ft)). The wire resistance of the cordset from the power supply to tap 1 (R_1) is:

$$R_1 = 0.02095 * L_1$$

The wire resistance must be considered for both the power and ground; therefore the voltage drop is multiplied by two. The voltage at connector J1 of tap T1 (V_{J1}) is:

$$V_{J1} = 2 * I_1 * R_1$$

The tap has a small voltage from connector J1 to J2. The typical voltage at connector J2 (V_{J2}) drop through the tap from J1 to J2 is:

$$V_{J2} = V_{J1} - (2 * 0.028V)$$

The voltage available at connector J3 is dependent on the device that is connected to J3. The typical voltage drop from J1 to J3 is 0.4V when the device uses 50 mA.

$$V_{J3} = V_{J1} - 0.4V \text{ (typical)}$$

IMPORTANT The voltage drop from J1 to J3 can be as high as 1.2V with a maximum load of 500 mA at the highest rated ambient temperature.
The TLS-ZR guard locking switch voltage drop is 0.29V when locked and 0.31V when unlocked.

The taps consume 25 mA when OFF. The EMSS taps consume an additional 15 mA (7.5 mA per channel) when the contacts are closed. The OSSD taps consume an additional 6 mA (3 mA per channel), when the outputs are ON.

A spreadsheet can be used to calculate the voltage available to the safety device. [Table 4 on page 26](#) shows the voltage available to the safety device of a number of different devices. Assuming that the power supply voltage is set to 24V, and the cable is the recommended 18 AWG, the voltage available to the safety devices is shown in the right-hand column.

When guard locking devices are used in the circuit, the taps and wiring components are subjected to momentary surges in current. With the sequential operation of the lock/unlock command, the momentary surges should not adversely affect the performance of the GuardLink circuit.

The operating voltage specification of the tap is 20.4...26.4V. In the example that is shown in [Table 4](#), the voltage at J1 of tap 6 has fallen below the lowest supply voltage specification of 20.4V DC. This system is not feasible, and remedial action must be taken (see [Table 5](#)).

IMPORTANT [Table 4](#) assumes the following:

- Supply voltage = 24V
- Link cable wire gauge = 18 AWG
- Link wire resistance = 0.02095 ohms/m

Table 4 - Voltage Calculation at 24V Supply

Tap	Cable Length [m (ft)]	Safety Device	Tap + Device Current (mA)	Total Current (mA)	J1 Voltage (V)	J3 Voltage Typical (V)
1	15 (49.2)	SensaGuard Ser A	81	1105	23.24	22.84
2	15 (49.2)	SensaGuard Ser A	81	1024	22.54	22.14
3	15 (49.2)	Lite Lock 440G-LZ	135	943	21.90	21.50
4	15 (49.2)	800F E-stop	40	808	21.34	20.94
5	15 (49.2)	LifeLine 4	40	768	20.82	20.42
6	15 (49.2)	LifeLine 5	81	728	20.32	19.92
7	15 (49.2)	TLSZR-GD2 PLe	135	647	19.88	19.48
8	15 (49.2)	TLSZR-GD2 PLe	135	512	19.53	19.13
9	15 (49.2)	Lite Lock 440G-LZ	135	377	19.27	18.87
10	15 (49.2)	SensaGuard Ser A	81	242	19.10	18.70
11	15 (49.2)	SensaGuard Ser A	81	161	18.99	18.59
12	15 (49.2)	Mechanical Switch	40	80	18.94	18.54
13	15 (49.2)	Mechanical Switch	40	40	18.91	18.51
14	0 (0)	—	0	0	—	—
15	0 (0)	—	0	0	—	—

To remedy the example in [Table 4](#), the supply voltage can be increased from 24V to 26V as shown in [Table 5](#). Now, all 13 taps meet the minimum voltage specification of 20.4V at connector J1.

IMPORTANT [Table 5](#) assumes the following:

- Supply voltage = 26V
- Link cable wire gauge = 18 AWG
- Link wire resistance = 0.02095 ohms/m

Table 5 - Voltage Calculation at 26V Supply

Tap	Cable Length [m (ft)]	Safety Device	Tap + Device Current (mA)	Total Current (mA)	J1 Voltage (V)	J3 Voltage Typical (V)
1	15 (49.2)	SensaGuard Ser A	81	1105	25.24	25.84
2	15 (49.2)	SensaGuard Ser A	81	1024	24.54	24.14
3	15 (49.2)	Lite Lock 440G-LZ	135	943	23.90	23.50
4	15 (49.2)	800F E-stop	40	808	23.34	23.94
5	15 (49.2)	LifeLine 4	40	768	22.82	22.42
6	15 (49.2)	LifeLine 5	81	728	22.32	21.92
7	15 (49.2)	TLSZR-GD2 PLe	135	647	21.88	21.48
8	15 (49.2)	TLSZR-GD2 PLe	135	512	21.53	21.13
9	15 (49.2)	Lite Lock 440G-LZ	135	377	21.27	20.87
10	15 (49.2)	SensaGuard Ser A	81	242	21.10	20.70
11	15 (49.2)	SensaGuard Ser A	81	161	20.99	20.59
12	15 (49.2)	Mechanical Switch	40	80	20.90	20.54
13	15 (49.2)	Mechanical Switch	40	40	20.91	20.51
14	0 (0)	—	0	0	—	—
15	0 (0)	—	0	0	—	—

Tap Cabling

The GuardLink system was designed with the intent to minimize wiring by using quick-disconnect patchcords, while also allowing some manual wiring to terminals, when pinout incompatibilities exist.

Figure 7 shows the recommended cable options for the various stages of a GuardLink system (to show the cable options only two taps are required, a full system has 32 taps). These cables are red-colored, PVC, unshielded, with epoxy-coated hardware. Although any color jacket can be used, the red color is preferred to indicate a safety circuit.

Visit ab.rockwellautomation.com/Connection-Devices/DC-Micro-Cordsets-and-Patchcords for other options, like right-angle connectors, stainless steel couplings, and shielded cables.

To maintain the safety integrity of the GuardLink signal, the wiring distance between taps is limited to 30 m (98.4 ft) and requires 18 AWG (0.82 mm²) wire. If the distance between devices is greater than 30 m (98.4 ft), then a tap must be inserted at least every 30 m (98.4 ft). A field-attachable quick-disconnect can be wired as a shorting plug for the device connection. The wiring distance between taps and the safety device is limited to 10 m (32.8 ft), and requires at least 24 AWG (0.2 mm²) wire size.

Figure 7 - Recommended Cable Options ⁽¹⁾

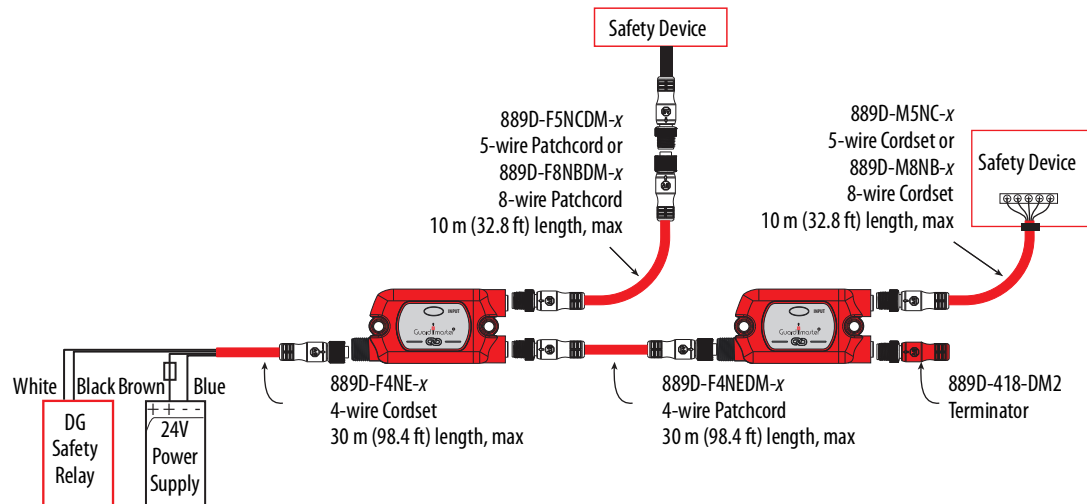

(1) Replace the x with OM3 (0.3 m [0.984 ft]), OM6 (0.6 m [1.968 ft]), 1 (1 m [3.28 ft]), 2 (2 m [6.56 ft]), 5 (5 m [16.4 ft]), 10 (10 m [32.8 ft]), 15 (15 m [9.2 ft]), 20 (20 m [65.6 ft]), or 30 (30 m [98.4 ft]) for standard cable lengths.

Terminator

The terminator ([Figure 8](#)), must be installed on the last tap to complete the link connection. The terminator contains internal electrical components specifically for a GuardLink system; other terminators cannot be used as substitutes.

TIP To help troubleshoot a GuardLink system, reduce the number of taps in the GuardLink circuit by relocating the terminator. After relocation, cycle power to the DG safety relay to allow the DG safety relay to relearn how many taps are connected. If the 440R-ENETR interface is used, then it must also be power cycled, and its AOP must be updated.

Figure 8 - Terminator — Catalog Number 898D-418U-DM2



Tap Replacement

A GuardLink tap can be replaced with the same type of tap while the link is powered. When the connections are remade; the GuardLink circuit recovers automatically.

When a GuardLink tap is replaced with another type of tap, removed from the circuit, or added to the circuit; cycle power to the DG safety relay to allow the DG safety relay to relearn how many and what types of taps are connected. If the 440R-ENETR interface is used, then it must also be power cycled, and its AOP must be updated.

Response Time

The GuardLink circuit has a fast response time. When a safety device opens, the tap responds within 5 ms. The GuardLink safety signal then travels upstream to the DG safety relay, which takes an additional 35 μ s through each upstream tap.

[Figure 9 on page 30](#) shows an example GuardLink safety circuit with six taps. In this example, a SensaGuard rectangular flat pack interlock, which is connected to Tap 4, opens.

Figure 9 - Response Time Example Calculation

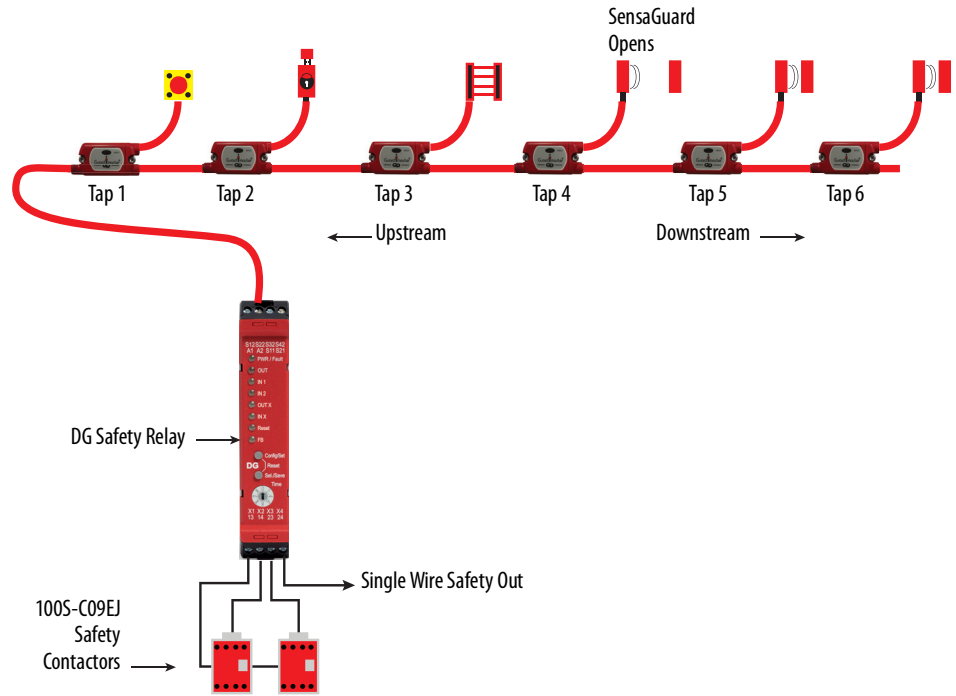

The safety system response time for the system that is shown in [Figure 9](#) is listed in [Table 6](#). The time from when the SensaGuard interlock opens to the time when the 100S contactors drop out is 169.105 ms. The time from when the SensaGuard interlock opens to the time when the SWS signal turns OFF is 114.105 ms.

Table 6 - Example Response Time Calculation

Component	Response Time [ms]	
	DG Output 13/14, 23/24	DG Output SWS (X2)
SensaGuard ⁽¹⁾	54.0	54.0
Tap 4	5.0	5.0
Tap 3	0.035	0.035
Tap 2	0.035	0.035
Tap 1	0.035	0.035
DG Safety Relay	60.0	55.0
100S Contactor ⁽²⁾	50.0	0.0
Total	169.105	114.105

(1) See publication [440N-IN008](#).

(2) See publication [100-TD013](#).

IMPORTANT [Figure 9](#) and [Table 6](#) show only a portion of a complete safety system. Additional time (for example, for motor stopping time and the response time of additional components that are connected to the SWS signal) must be considered.

Installation

The DG safety relay uses the same housing as GSR modules. The module dimensions are shown in [Figure 10](#), while [Figure 11](#) shows the tap dimensions.

Mounting Dimensions

Figure 10 - DG Safety Relay Dimensions [mm (in.)]

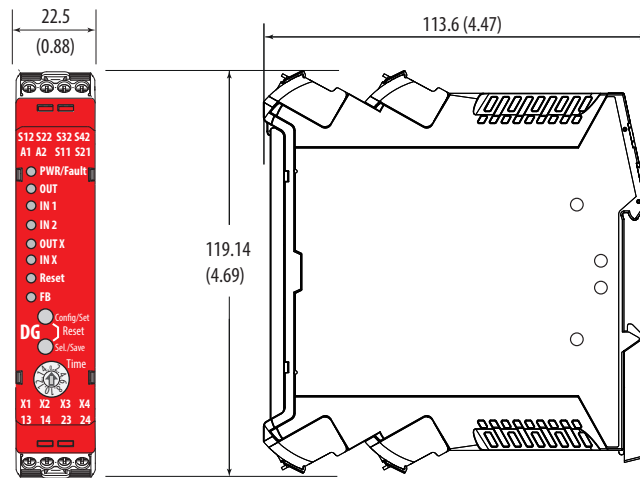
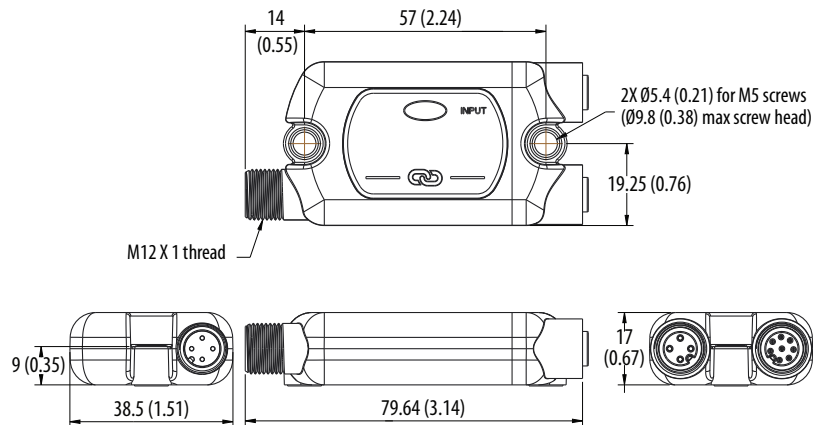

Figure 11 - Tap Dimensions [mm (in.)]



DIN Rail Mounting and Removal

The DG safety relay easily mounts onto 35 mm (1.4 in.) DIN rails: 35 x 7.5 x 1 mm (1.4 x 0.3 x 0.04 in.) (EN 50022 - 35x7.5).

1. Hold the top at an angle ([Figure 12](#)).
2. Slide down until the housing catches the rail.
3. Swing the bottom down and give a little push until the latch clips onto the rail.

Figure 12 - DIN Rail Mounting

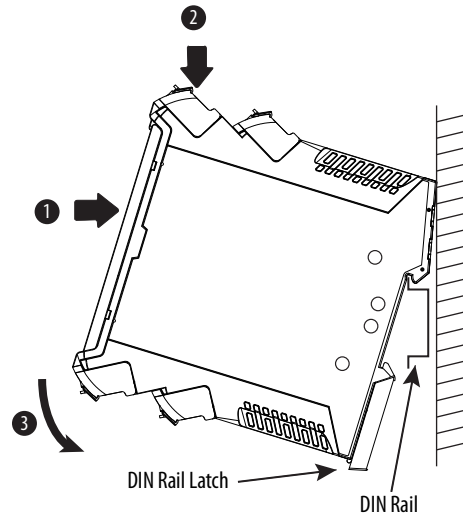

Removal

To remove the DG safety relay, use a screwdriver to pry the DIN rail latch downwards until it is in the unlatched position. Then, swing the module up.

Spacing

The DG safety relay can be mounted next to other GSR safety relays. When the GSR Ethernet interface is used, the GSR module must be mounted within 10 mm (0.39 in.) of the module next to it to maintain effective communications.

Maintain 50 mm (2 in.) of space above, below, and in front of the relay for adequate ventilation.

Terminal Block Removal and Replacement

Terminal blocks can be removed and replaced following these instructions.

Terminal Block Removal

DG safety relays have removable terminal blocks. Use a screwdriver as a lever to remove the blocks. As shown in [Figure 13](#), insert the screwdriver into the slot and pry up.

Figure 13 - DG Terminal Removal

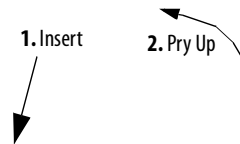

Terminal Block Replacement

The terminal blocks are keyed to help prevent a block from being inserted into an incorrect location. The orange-colored insert provides the orientation of the key ([Figure 14](#)).

Figure 14 - Orange-colored Keyway

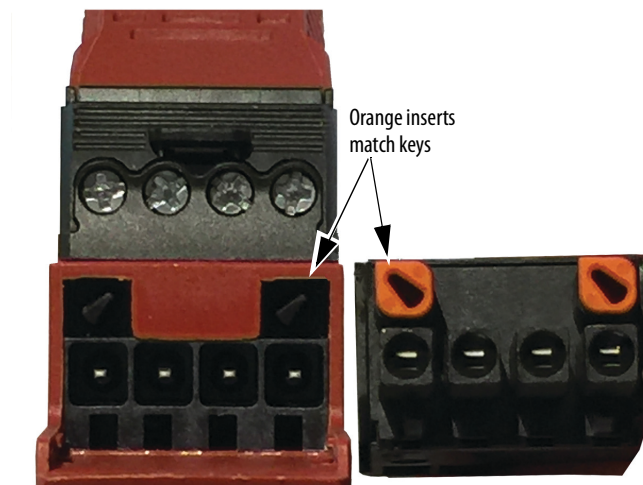

Tap Installation

The tap can be installed directly with two M5 screws. In [Figure 15](#), the 38.5 mm (1.5 in.) wide tap fits neatly on a standard 40 mm (1.6 in.) aluminum extrusion construction profile.

Figure 15 - Mounting Directly on 40 mm (1.6 in.) Profile

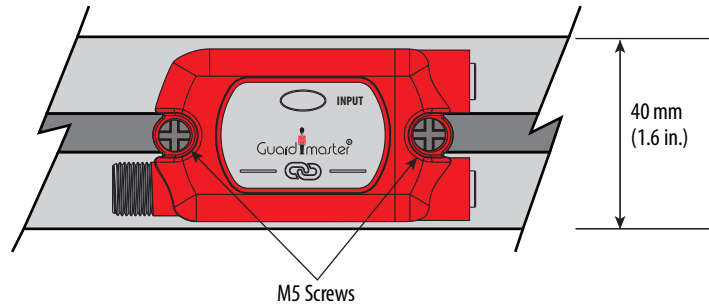

[Figure 16](#) shows an optional quick mounting bracket, catalog number 440S-GLTAPBRK⁽¹⁾, is available to facilitate installation and removal. The tap snaps into place and can be easily removed to install patchcords and cordsets.

Figure 16 - Quick-release Mounting Bracket

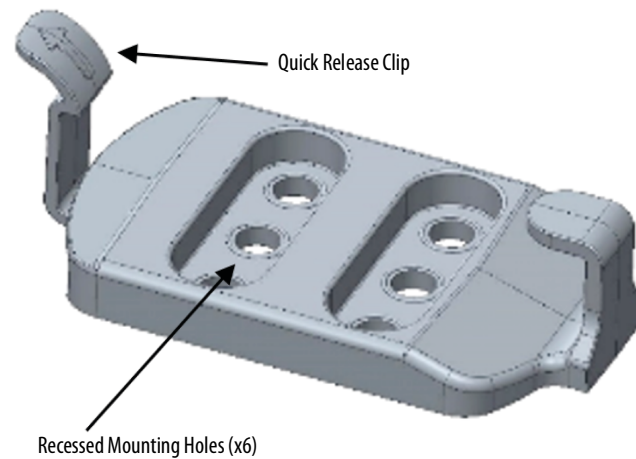

[Figure 17](#) shows the dimensions of the quick-release mounting bracket.

Figure 17 - Mounting Bracket Dimensions

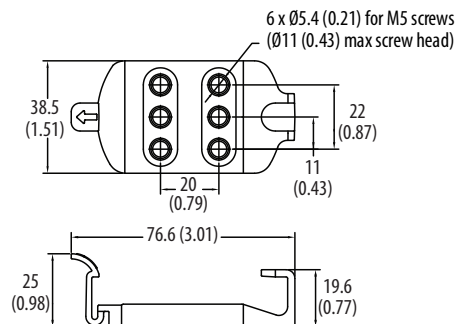

(1) Replace the x with 1 to order one bracket and replace with a 5 for a package of five brackets.

[Figure 18](#) shows some of the mounting options with the quick release bracket. The bracket can be mounted on various sizes of profile and can mount in-line or across the profile.

Figure 18 - Mounting Options with Quick-release Bracket

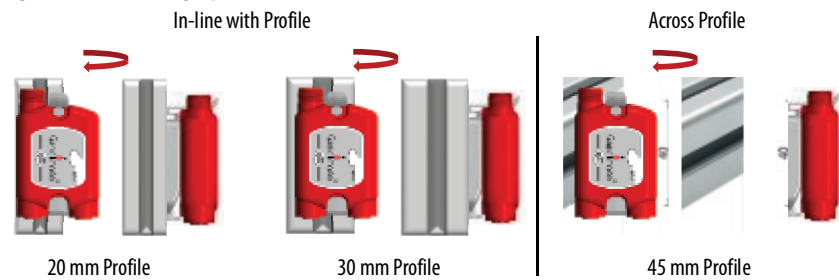

Enclosure Considerations

Consider the following when choosing your DG safety relay and tap enclosure.

DG Safety Relay

The DG safety relay is intended for use in a Pollution Degree 2 industrial environment, in overvoltage Category II applications (as defined in IEC 60664-1), at altitudes up to 2000 m (6562 ft) without derating. This equipment is considered Group 1, Class A industrial equipment according to IEC/CISPR 11. Without appropriate precautions, there can be difficulties with electromagnetic compatibility in residential and other environments due to conducted and radiated disturbances.

The DG safety relay is supplied as open-type equipment. It must be mounted within an enclosure that is suitably designed for those specific environmental conditions that are present and appropriately designed to help prevent personal injury that results from accessibility to live parts. The enclosure must have suitable flame-retardant properties to help prevent or minimize the spread of flame that complies with a flame spread rating of 5VA, V2, V1, V0 (or equivalent) if non-metallic. The interior of the enclosure must be accessible only by the use of a tool. Subsequent sections of this publication may contain additional information regarding specific enclosure type ratings that are required to comply with certain product safety certifications.

Other helpful publications can be found in [Additional Resources on page 9](#).

Taps

Taps are intended to be mounted on the machine and are rated for Pollution Degree 3.

Prevent Excessive Heat

Consider the following to help prevent excessive heat for your DG safety relay and tap.

DG Safety Relay

For most applications, normal convective cooling keeps the DG safety relay within the specified operating range. Verify that the specified temperature range is maintained. Proper spacing of components within an enclosure is usually sufficient for heat dissipation.

In some applications, other equipment inside or outside the enclosure produce a substantial amount of heat. In this case, place blower fans inside the enclosure to help with air circulation and to reduce hot spots near the controller.

Additional cooling provisions can be necessary when high ambient temperatures are encountered. Do not bring in unfiltered outside air. Place the controller in an enclosure to help protect it from a corrosive atmosphere. Harmful contaminants or dirt can cause improper operation or damage to components. In extreme cases, you may need to use air conditioning to help protect against heat buildup within the enclosure.

Taps

The taps have no spacing requirements.

Power, Ground, and Wire

Wiring Requirements and Recommendation



WARNING: Before you install and wire any device, disconnect power to the system.



WARNING: Calculate the maximum possible current in each power and common wire. Observe all electrical codes that dictate the maximum current allowable for each wire size. Current above the maximum rating can cause wiring to overheat, which can cause damage.

- Allow for at least 50 mm (2 in.) between I/O wire ducts or terminal strips and the relay.
- Route incoming power to the relay by a path separate from the device wiring. Where paths must cross, their intersection must be perpendicular.
- Do not run signal or communications wiring and power wiring in the same conduit. Route wires with different signal characteristics by separate paths.
- Separate wiring by signal type. Bundle wiring with similar electrical characteristics together.
- Separate input wiring from output wiring.
- Label wiring to all devices in the system. Use tape, shrink-tubing, or other more dependable means to label wire. Use colored insulation as well to identify wiring by signal characteristics. For example, use blue for DC wiring and red for AC wiring.

DG Safety Relay

Wire Size

Each terminal can accommodate copper wire with size from 0.2...2.5 mm² (24...14 AWG). Use copper that can withstand 60/75 °C (140/167 °F).

Terminal Torque

Torque terminals to 0.4 N•m (4 lb•in).

Terminal Assignment and Function

The relays have four terminals: two on the top and two on the bottom. As shown in [Figure 19](#), the X2 and X4 terminal markings apply to the terminals further back. The X1 and X3 terminals apply to the terminals closest to the front.

Figure 19 - DG Terminal Identification

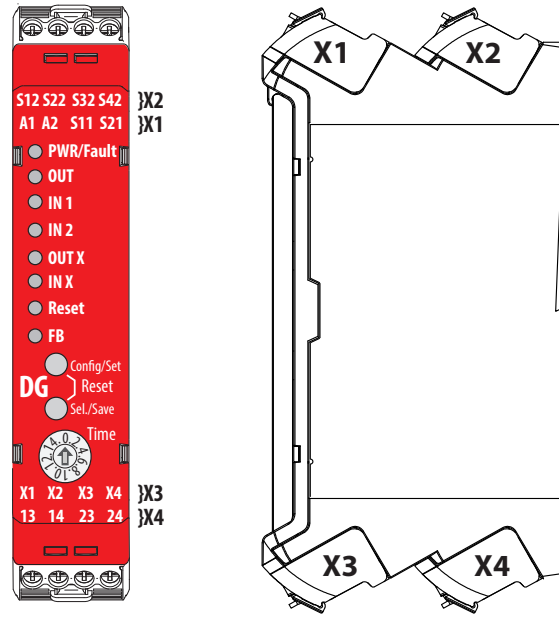

Some of the terminals can be configured for multiple functions. [Table 7](#) lists the functions available for each terminal.

Table 7 - Terminal Assignments and Functions

Terminal	Function
A1	+24V Supply (+10%, -15%)
A2	0V Common
S11	Pulse Test Output
S21	Pulse Test Output
S12	GuardLink Safety or Safety N.C.
S22	GuardLink CLU or Safety N.C.
S32	GuardLink Safety or Safety N.C.
S42	GuardLink CLU or Safety N.C.
X1	SWS In or OSSD In
X2	SWS Out or OSSD Out
X3	Standard Input (Feedback)
X4	Standard Input (Reset)
13	Redundant Positive-Guided Relay Output 1
14	
23	Redundant Positive Guided Relay Output 2
24	

Tap Pin Assignment and Function

Each tap has three M12 quick disconnect connectors ([Figure 20](#)). The system is designed to use premanufactured patchcords to facilitate installation, modification, and troubleshooting. The link connectors are 4-pin. The device connectors are either 5-pin or 8-pin.

Figure 20 - Tap Connection Identification

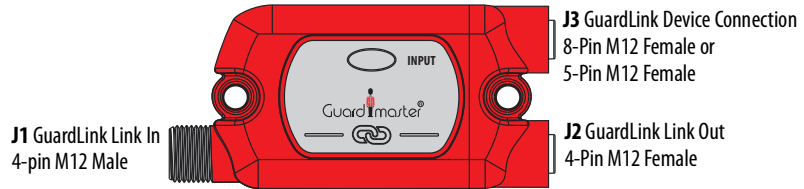

The link connections carry the power and command signals. [Figure 21](#) shows the functions of each pin. When using Allen-Bradley® Guardmaster patchcords and safety devices, you do not need to be concerned about the pin assignments, the system is connect and go.

Figure 21 - Link Connections

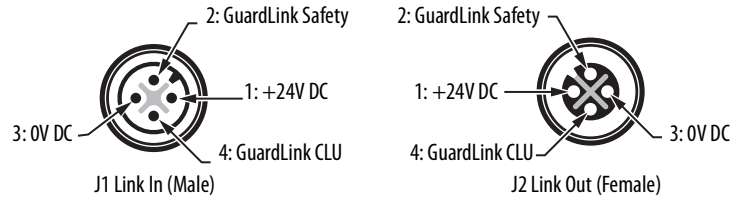

Pin	Function
1	+24V Supply (+10%, -15%)
2	GuardLink Safety Signal
3	0V DC, the reference for the 24V supply
4	GuardLink Control Lock Unlock (CLU) Signal

[Figure 22](#)...[Figure 25](#) show the functions that are assigned to the 8-pin and 5-pin quick-disconnect connections for safety devices. These figures include tables with the wire colors of the recommended cordset that can be used where a patchcord cannot.

Figure 22 - J3 8-Pin OSSD (Female) Connector

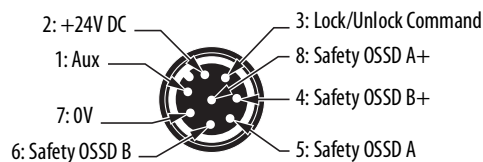

Pin	Function	Cordset Wire Color
1	The auxiliary status output signal is not used by the tap	White
2	+24V Supply (+10%, -15%)	Brown
3	The Lock/Unlock command to the device	Green
4	Safety OSSD channel B+ (24V DC, no pulse test)	Yellow
5	Safety OSSD channel A	Gray
6	Safety OSSD channel B	Pink
7	0V DC, the reference for the 24V supply	Blue
8	Safety OSSD channel A+ (24V DC, no pulse test)	Red

Figure 23 - J3 8-Pin EMSS (Female) Connector

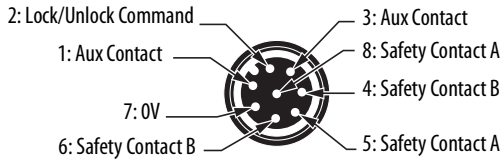

Pin	Function	Cordset Wire Color
1	Auxiliary (non-safety) contact	White
2	Lock/Unlock command	Brown
3	Auxiliary (non-safety) contact	Green
4	24V output for safety contact channel B	Yellow
5	Safety contact channel A	Gray
6	Safety contact channel B	Pink
7	0V DC, the reference for the Lock/Unlock command	Blue
8	24V output for safety contact channel A	Red

Figure 24 - J3 5-pin OSSD (Female) Connector

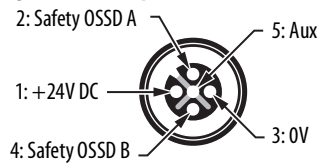

Pin	Function	Cordset Wire Color
1	The +24V power supply to the device	Brown
2	Safety OSSD channel A	White
3	0V DC, the reference for the power supply	Blue
4	Safety OSSD channel B	Black
5	The auxiliary status signal is not used by the tap	Gray

Figure 25 - J3 5-pin EMSS (Female) Connector

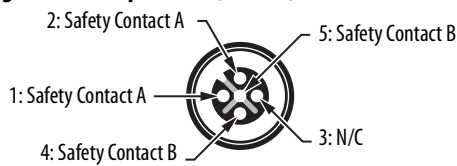

Pin	Function	Cordset Wire Color
1	24V output for safety contact channel A	Brown
2	Safety contact channel A	White
3	0V DC (the reference for the power supply)	Blue
4	Safety contact channel B	Black
5	24V output for safety contact channel B	Gray

Bulletin 871A field-attachable quick-disconnect connectors can be used as shorting plugs during installation, troubleshooting, and for long distances. When the distance between taps exceeds 30 m (98.4 ft), a tap must be inserted into the GuardLink system at least every 30 m (98.4 ft). A shorting plug must then be added to the J3 connector. [Figure 26](#) shows the wiring connections that are required to create a shorting plug.

IMPORTANT For 5-pin OSSD taps, a shorting plug (catalog number 898D-418U-DM) can be used in place of the terminal chamber (catalog number 871A-TS5-DM).
 For 8-pin taps, a shorting plug (catalog number 898D-81RU-DM2) can be used in place of the terminal chamber (catalog number 871A-TS8-DM1).

Figure 26 - Shorting Plug Schematics

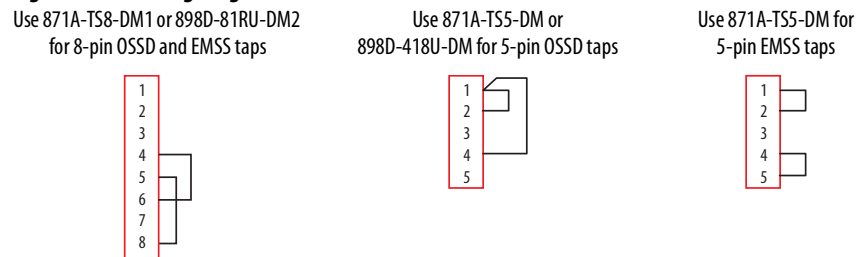

Power Supply Connection

Many Bulletin 1606 power supplies are SELV, PELV, and Class 2-compliant.

DG Safety Relay

To comply with the CE (European) Low Voltage Directive (LVD), a DC source compliant with protected extra low voltage (PELV) or, under certain conditions, a safety extra low voltage (SELV) per IEC 60204-1 must power the DG safety relay.

For the USA, a PELV supply is required, per NFPA 79.

[Figure 27](#) shows the power supply connections for the DG safety relay. Connect terminal A1 to +24V DC. Terminal A2 must be connected to the common of a 24V supply.

Figure 27 - DG Power Supply Connections

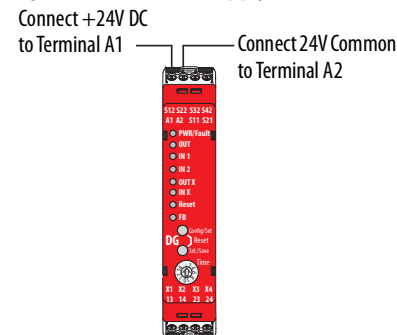

Taps

To comply with the CE (European) Low Voltage Directive (LVD), a DC source compliant with a protected extra low voltage (PELV) or, in certain circumstances, a safety extra low voltage (SELV) per IEC 60204-1 must power the tap. For IEC applications, an in-line, slow-blow 4 A fuse is recommended if the power supply can provide more than 4 A.

For the USA, a Class 2 power supply must be used. The Class 2 supply limits the current to 4 A, so an in-line fuse is not needed.

IMPORTANT In the USA, use of a 4 A fuse or circuit breaker in place of a Class 2 power supply is not acceptable.

Figure 28 shows the power connections to the power tap. Power is connected only to the first tap.

Figure 28 - Tap Power Connections

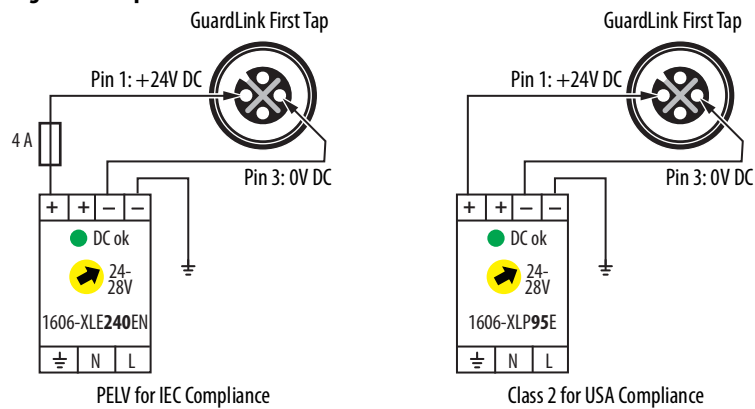

Multiple Power Supplies

When separate power supplies are used for the DG safety relay and the GuardLink circuit, the protective earth connections must be at the same point. [Figure 29](#) shows an example wiring diagram (catalog number 1606-XLE240EN is not Class 2 compliant; catalog number 1606-XLP-95E is Class 2 compliant).

Figure 29 - Multiple Power Supplies — Ground PE at Same Point

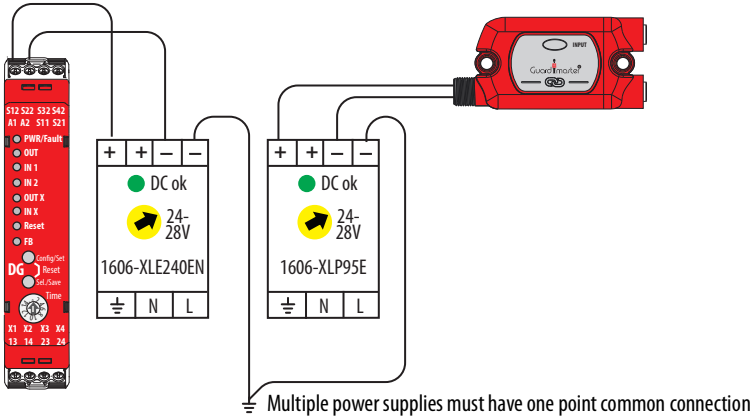

DG Safety Relay Input Wiring

This section describes DG safety relay input wiring.

GuardLink Connections

Up to two GuardLink circuits can be connected to the DG safety relay. The GuardLink safety signal must be connected to either S12 or S32 and the GuardLink CLU signal must be connected to either S22 or S42. [Figure 30](#) shows the connections for the GuardLink circuits; the wire colors apply when the recommended cordsets are used.

Figure 30 - GuardLink Connections

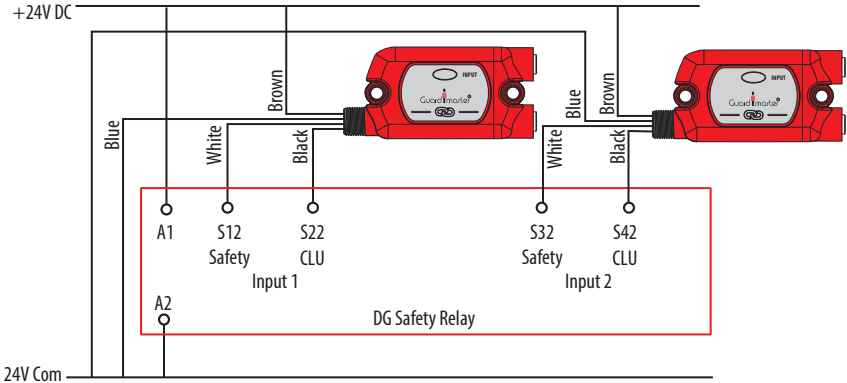

Devices with OSSD Outputs

Devices with OSSD outputs perform their own short circuit detection. The DG can be configured to accept up to two devices with OSSD signals. Connections of the OSSD outputs are shown in [Figure 31](#).

Figure 31 - Wiring to Devices with OSSD Outputs

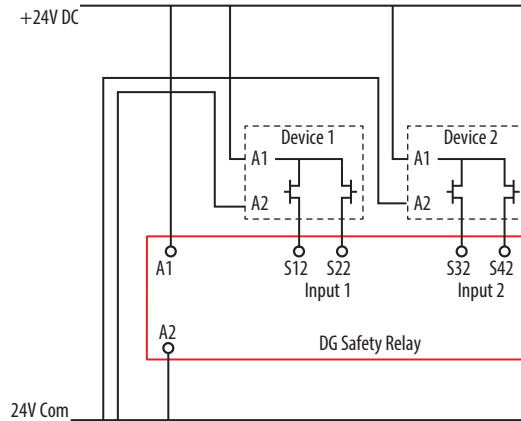

Voltage-free Contacts

Devices with voltage-free contacts must use the pulse testing outputs to detect short-circuit faults between the following:

- Channels
- Channels and power
- Channels and ground

[Figure 32](#) shows the recommended wiring for dual-channel and single-channel, voltage-free contacts. Voltage-free contacts can be connected to either Input 1, Input 2, or both inputs.

Figure 32 - Wiring to Voltage-free Contacts

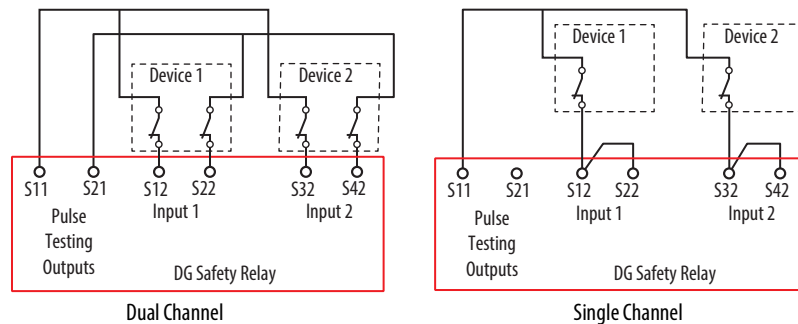

Single Wire Safety

The DG safety relay has the Single Wire Safety capability to expand the safety function (both input and output).

SWS Connections

The Single Wire Safety (SWS) feature allows a safety relay to expand the safety function to additional safety relays using one wire, provided all safety relays have the same voltage supply reference.

The SWS signal is unidirectional. The signal flows from L11 to L12.

There can be many variations and combinations of series and parallel connections of the SWS. Each L11 terminal can be connected to up to ten L12 terminals.

IMPORTANT Do not connect two or more L11 terminals together.

[Figure 33](#) shows an example wiring diagram with an SWS signal. The SWS can be connected between the DG safety relay and other relays in the GSR family (the CI, DI, DIS, EM, EMD, and SI relays). Relay 1 has a series connection to Relay 2. Relay 2 has a parallel connection to Relays 3 and 4. Relay 4 has a series connection to Relay 5. The safety relays must have a common power reference (24V common). In this example, the safety function started by Relay 1 turns off all other relays if AND logic is applied to L12 on all relays.

IMPORTANT The DG safety relay terminals are marked X2 and X1; which is equivalent to terminal L12 and L11 on other GSR relays.

Figure 33 - SWS Connection Example

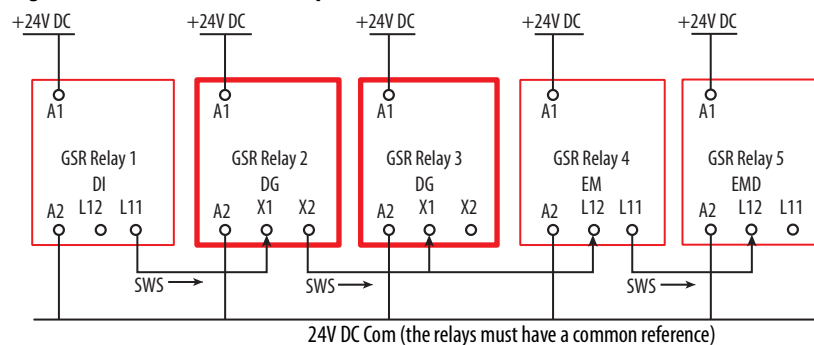
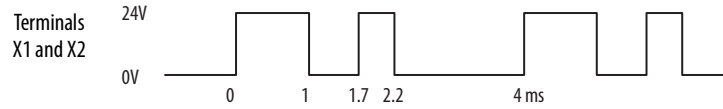

Figure 34 shows the characteristics of SWS signal when it is active. It starts with a 1 ms pulse, followed 700 μ s later by a 500 μ s wide pulse. This waveform is repeated every 4 ms. The tolerance of all edges is $\pm 10\%$.

When inactive, the SWS signal is 0V.

Figure 34 - SWS Waveform



Safety Output Wiring

The DG safety relay has two voltage-free, safety-related outputs (terminals 13/14 and 23/24).

13/14 and 23/24 Safety Outputs

The 13/14 and 23/24 safety outputs have redundant (two) positive-guided relays that are internally connected between each terminal. An example of the wiring connections is shown in Figure 35. See [Specifications on page 65](#) for the voltage and current ratings of these relays.

If the voltage supply of the outputs exceeds the voltage supply of the relay, then low-voltage wiring must be separated from the high-voltage wiring.

Figure 35 - Output Connections of the DG Safety Relay

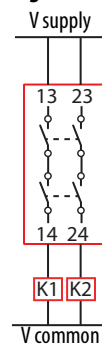

Surge Protection

Due to potentially high-current surges that occur when switching inductive load devices, such as motor starters and solenoids, the use of some type of surge suppression to help protect and extend the operating life of the relays is recommended. By adding a suppression device directly across the coil of an inductive device, you prolong the life of the outputs. You also reduce the effects of voltage transients and electrical noise from radiating into adjacent systems.

[Figure 36](#) shows an output with a suppression device. We recommend that you locate the suppression device as close as possible to the load device.

For outputs that use 24V DC, we recommend 1N4001 (50V reverse voltage) to 1N4007 (1000V reverse voltage) diodes for surge suppression for the OSSD safety outputs ([Figure 31](#)). The diode must be connected as close as possible to the load coil.

For outputs that use 120V AC or 240V AC, we recommend metal oxide varistors.

Figure 36 - Surge Protection Examples

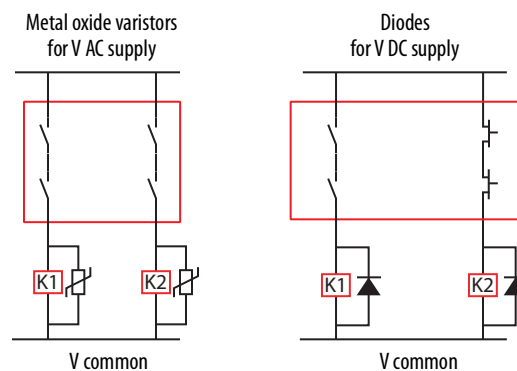

[Table 8](#) lists the recommended surge suppressors for some commonly used safety control relays and contactors.

Table 8 - Surge Suppressor Recommendations

Safety Control Relay or Contactor	Coil Voltage	Suppressor
100S-C09QJxxxBC ⁽¹⁾ 100S-C09EJxxxBC 700S-CFBxxxQJBC 700S-CFBxxxEJBC	24V DC Electronic Coil	—
700S-DCPxxxDZ24 700S-DCPxxxZ24	24V DC	199-FSMZ-1
700S-PxxxA1	120V AC	199-FSMA10
700S-PxxxA2	240V AC	199-FSMA11

(1) The QJ coil drops out faster than the EJ coil and is preferred when response time is important. The “B” bifurcated auxiliary contacts are recommended, as the safety monitoring current is typically on the order of a few milliamps.

Notes:

Configuration

The DG safety relay has two push buttons on the front faceplate. These buttons are labeled Config/Set and Sel./Save.

These push buttons allow you to do the following:

- Configure the DG safety relay to perform a safety function
- Confirm the existing safety functions
- Reset the DG safety relay
- Report the fault code

The DG safety relay has two modes of operation: run and configuration. The functions that the push buttons perform depend on the operating mode and length of time the push button is pressed.

- Short: The button is pressed less than 1 second.
- Long: The button is pressed for longer than 3 seconds, but shorter than 10 seconds.

Config/Set Push Button

Run Mode

Button Press	Function
Short	<p>The indicators show the configuration of the DG safety relay.</p> <ul style="list-style-type: none"> • Press once to see the configuration (see Table 9 on page 51). • Press a second time to see the time delay setting (see Table 10 on page 53). • Press a third time to see the status of the wiring terminals again (see Table 12 on page 55). <p>After about 20 seconds of inactivity, the indicators revert to the wiring terminal status.</p>
Long	<p>The DG safety relay enters Configuration mode. The 13/14, 23/24, and X2 outputs turn OFF, if they are ON.</p> <p>After 60 seconds of inactivity, the indicators revert to the wiring terminal status. Changes to the configuration are not saved.</p>

IMPORTANT After changes to the hardware configuration of the DG safety relay or the GuardLink circuit, power must be cycled to the DG safety relay, the GuardLink circuit, and the EtherNet/IP interface.

Configuration Mode

When you are in the configuration mode, the duration that the Config/Set button is depressed determines what the DG safety relay reveals.

Button Press	Function
Short	You can cycle through the configuration and can switch between the function of the blinking indicator. See Table 9 for indicator descriptions.
Long	Abort the changes; you leave the configuration mode without saving the changes. The PWR/Fault indicator flashes green at a 1 Hz rate. Upon release, the indicators revert to the wiring terminal status.

Sel./Save Push Button

Run Mode

Button Press	Function
Short	The status indicators display the following: <ul style="list-style-type: none"> • Alternating flashing green indicators if optical buses are active. • Alternating flashing red indicators if optical buses are inactive.
Long	Nothing happens.

Configuration Mode

Button Press	Function
Short	You can jump from one configuration step to the next.
Long	The new configuration is saved.

















Reset

If you press both push buttons simultaneously for longer than 3 seconds, the DG safety relay performs a power cycle. The same can be accomplished if you remove and reapply power to terminal A1.

Configuration Steps

Before starting to configure the DG safety relay, review the configuration functions in [Table 9](#). The configuration examples in [Appendix B](#) help you select the correct configuration.

Table 9 - Configuration

Status Indicator	Function	Indicator Color and Setting	Indicator Color and Setting	Indicator Color and Setting
OUT	Number of Safety Functions	 Activate two Safety Functions (IN1 and IN2)	 Activate one Safety Function (only IN1)	—
IN 1	Input Type IN1	 Activate GuardLink Input function on IN1	 Activate OSSD or EMSS Input function on IN1	—
IN 2	Input Type IN2	 Activate GuardLink Input function on IN2	 Activate OSSD or EMSS Input function on IN1	 If only one Safety Function (IN1) is selected, the IN2 is disabled
OUT X	Output Type	 Activate SWS Output on X2	 Activate OSSD Output on X2	—
IN X	Input Mode	 Activate SWS or OSSD Input on X1, depends on the previous step (SWS Input if OUT X is SWS Out, OSSD In out if OUT X is OSSD.)	 Disable Input on X1	—
Reset	Reset Type	 Manual Monitored Reset	 Automatic Reset	—
FB	Reset Assignment	 Reset on the Output function	 Reset only on IN 1 ⁽¹⁾	 Not used if Automatic Reset is selected

(1) Only available if Manual Monitored Reset is selected.

1. Long press the Config/Set button.

The PWR/Fault indicator turns green and all other indicators flash red quickly, which indicates that the DG safety relay is in Configuration mode. Shortly after release of the Config/Set button:

- The PWR/Fault status indicator flashes green at 1 Hz.
- The OUT status indicator flashes the current configuration (red or green) at 1 Hz.
- The remaining status indicators are solid red, solid green, or off.

2. Short press the Config/Set button to change the function of the OUT status indicator.

IMPORTANT If you press the Config/Set button in these steps again, the status indicator switches back and forth between red and green.

Short press the Sel./Save button to accept and go to the next step.

3. Short press the Config/Set button to change the function on the IN 1 status indicator.

Short press the Sel./Save button to accept and go to the next step.

IMPORTANT If the IN 2 indicator is off, the function is not available in this configuration. The configuration proceeds to the OUT X indicator - go to [step 5](#).

4. Short press the Config/Set button to change the function on the IN 2 status indicator, if available.
Short press the Sel./Save button to accept and go to the next step.
5. Short press the Config/Set button to change the function on the OUT X status indicator.
Short press the Sel./Save button to accept and go to the next step.
6. Short press the Config/Set button to change the function on the IN X status indicator.
Short press the Sel./Save button to accept and go to the next step.
7. Short press the Config/Set button to change the function on the Reset status indicator.
Short press the Sel./Save button to accept and go to the next step.
8. Short press the Config/Set button to change the function on the FB status indicator.
Short press the Sel./Save button to accept and go to the next step.
9. All indicators flash the new configuration. Use this step to confirm your configuration.
Short press the Sel./Save button to accept and go to the next step.
10. Now, you can verify and adjust the time delay. If the rotary switch is at position 0, all indicators (except the PWR/Fault) are off. If the rotary switch is in a position other than 0, then the bottom three indicators flash. The number of times the indicators flash is equal to the Time switch position.
11. Rotate the rotary switch to the desired off-delay setting (see [Table 10 on page 53](#)).
12. When the configuration is finished, long press the Sel./Save button to save the new configuration.

The status indicators flash their configuration while the button is held down. When the button is released, the PWR/Fault status indicator flashes green twice, turns solid red for about 5 seconds, and then turns solid green again. Now, the other status indicators reflect the status of the wiring terminals (see [Table 12 on page 55](#)).

-
- IMPORTANT** To abort the configuration without saving your settings:
- Long press the Config/Set button, then short press the Config/Set button. Then, you must either press and hold both the Config/Set and Sel./Save buttons for 3 seconds to perform a reset or cycle power to the DG safety relay.
 - Wait longer than 60 seconds without any additional changes.
-

Delay Setting









The delay is set by the 16 position switch as described in [Table 10](#). The DG inputs must be opened during the delay. If the inputs close before the expiration of the delay time, the delayed output remains ON and any locked guards remain locked. If the inputs are reopened, the timer restarts from zero.

Table 10 - Delay Switch Settings

Position	Delay	Position	Delay
0	Immediate	8	3 s
1	100 ms	9	5 s
2	200 ms	10	8 s
3	300 ms	11	10 s
4	500 ms	12	15 s
5	1 s	13	20 s
6	1.5 s	14	25 s
7	2 s	15	30 s

[Table 11](#) shows how the status indicators confirm the delay setting. The bottom three indicators flash at 1 Hz. The flashing pauses for 4 seconds and then repeats. The number of flashes is equal to the delay switch setting.

Table 11 - Indicators Confirm Delay Setting

Indicator	Color	Status
PWR/Fault		Configuration mode
OUT		—
IN 1		—
IN 2		—
OUT X		—
IN X		The number of flashes indicates the delay switch setting. For example: 0 = no flashing 5 = five flashes
Reset		
FB		

Verification

You can verify the configuration of the DG safety relay in three ways:

- The push buttons on the front of the DG safety relay
- The 440R-ENETR interface webpage
- The Add-on Profile (AOP) in the Studio 5000 environment

Push Buttons on the Front of DG Safety Relay

While in the Run mode, short presses of the Config/Set button can verify the configuration.

IMPORTANT The PWR/Fault indicator remains green through these steps.

1. Short press the Config/Set push button.

The indicators show the configuration. Compare the colors of each indicator to your desired colors.

2. Short press the Config/Set push button again.

The indicators show the Time switch setting. If the indicators are off, then the TIME is set to zero. For a setting other than zero, the bottom three indicators flash green. The number of flashes is equal to the switch setting. The flashing pauses for 4 seconds and then repeats.

3. Short press the Config/Set push button one last time to return to the running status indication.

AOP in the Studio 5000 Environment

Each configuration is assigned a unique identification. The ID appears as a decimal value in the Config field in the Controller Tags. See publication [440R-UM009](#) for details. After the initial configuration, record the Config value. This value can then be compared in the future to detect changes.

Status Indicators

DG Safety Relay Status Indicators

[Table 12](#) describes the status of the DG safety relay status indicators during normal operation.

Table 12 - DG Indicators during Normal Operation

Indicator	State	Description
PWR/Fault	OFF	No power
	Solid Red	DG safety relay is in self-test state or idle state
	Solid Green	Normal operation (Run mode)
	Flashing Green 1 Hz	Configuration mode - proceed with configuration
	Flashing Red 1 Hz	Fault Mode - See Appendix D on page 55 to determine the fault.
OUT	Green	Output circuits at 13/14 and 23/24 are closed
	Red	Output circuits at 13/14 and 23/24 are open
IN 1	Green	Input circuits at S12 and S22 are closed
	Red	Input circuits at S12 and S22 are open
	Flashing Red 1 Hz	Input signal missing, incorrect configuration, fault on a tap, or short circuit of input S12 or S22 to power or ground.
IN 2	Green	Input circuits at S32 and S42 are closed
	Red	Input circuits at S32 and S42 are open
	Flashing Red 1 Hz	Input signal missing, incorrect configuration, or short circuit from S11 or S21 to 24V or to 0V. If short circuit, remove short circuit and cycle the input device to clear fault.
	OFF	Input circuit is disabled
OUT X	Green	OSSD output/SWS output at X2 is ON
	Red	OSSD output/SWS output at X2 is OFF
	Flashing Red 1X	Wiring short from terminal X2 to 24V or to 0V when X2 is configured as SWS.
	Alternate Flashing Green/Red	Wiring short from terminal X2 to 0V when X2 is configured as OSSD.
IN X	Green	Input circuit at X1 closed
	Red	Input circuit at X1 open
	OFF	Input circuit is disabled
Reset	Green	Reset button at X4 pushed
	Flashing Green 1 Hz	Reset at X4 required
	Flashing Red 1 Hz	Reset at X4 held ON. Try resetting again.
FB	Green	Feedback circuit at X3 closed
	OFF	Feedback circuit at X3 open

Tap Status Indicators

Figure 37 shows the location of the two tap indicators: one for the input device connection and one for the link connection. Table 13 provides a description of the status for each indicator.

Figure 37 - Tap Indicators

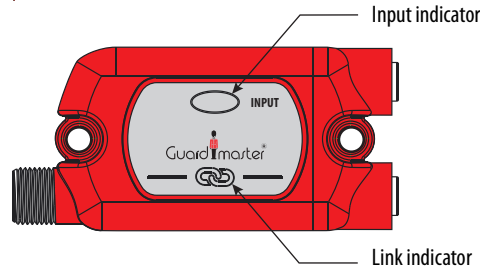
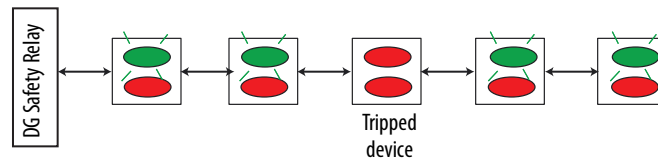

Table 13 - Tap Indicators

Indicator	State	Description
Input	Solid Green	The input device is in the operational state with no demand on its safety function (for example, the OSSD inputs are ON or safety contacts are closed). The tap is also in the operational state.
	Flashing Green at 1 Hz	The input device is in the operational state (no demand on its safety) and the tap is in the safe state. One or more upstream taps are in a safe state. The CLU signal is high, so all taps are in the safe state.
	Solid Red	OSSD inputs are OFF or safety contacts are open. The input device is in the safe state (for example, OSSD inputs are OFF or safety contacts are open), and there are no faults with the tap.
	Flashing Red at 1 Hz	The input device has not performed as expected; for example, both inputs did not change simultaneously. Try cycling the input device again. Cycle power to GuardLink circuit if necessary.
Link	Solid Green	The tap is transmitting the safety signal.
	Solid Red	GuardLink safety signal is OFF. Or terminator is missing.
	Flashing Red at 1 Hz	Fault at tap or input device. Correct fault and cycle power to the GuardLink system.
	Off	No communication to DG safety relay. Input is configured for OSSD/EMSS; recheck the configuration. Input is in faulted state. Correct fault and/or cycle power to the DG safety relay and GuardLink circuit.

Figure 38 shows an example with five taps. The device at Tap 3 has tripped, and the GuardLink safety signal is in a safe state. To locate the tripped device, follow the blinking green lights to the tap with the solid red device indicator. The link indicator is solid red, which indicates a safe (OFF) state.

Figure 38 - Tripped Device with Solid Red Status Indicators



Pulse Testing Functions

Your DG safety relay uses pulse testing of inputs with voltage free contacts to detect short circuit conditions. The test pulses are used to detect three short circuit conditions:

- Between the input terminals and +24V
- Between the input terminals and 24V common
- Between the two input terminals.

Pulse testing for the inputs must be used with devices like E-stop push buttons, tongue operated interlock switches, and limit switches that have voltage-free contacts.

The pulse-testing cannot be turned on or off and cannot be changed. Therefore, the purpose of this chapter is informational, but it can be used during troubleshooting of a DG safety circuit.

Pulse Testing for Inputs

Pulse tests for the inputs are generated on terminals S11 and S21 of the DG safety relay.

[Figure 39](#) shows the pulse testing that is associated with the DG safety relay. The pulse widths are either 300 μs or 600 μs wide, and the pulses are repeated every 15 ms.

Figure 39 - Pulse Test Sequence for DG Safety Relay

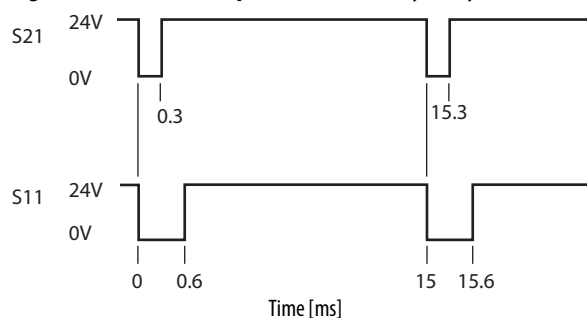

EMSS SmartTap Pulse Tests

The EMSS SmartTap generates pulse tests to detect short circuit conditions. The waveforms are shown in [Figure 40](#). The pulses are 1 ms wide. Channel 2 pulse occurs 8 ms after Channel 1. The pulses are repeated every 21 ms. When either of the input channels goes to an open state, the pulses are turned off.

Figure 40 - EMSS Test Pulses

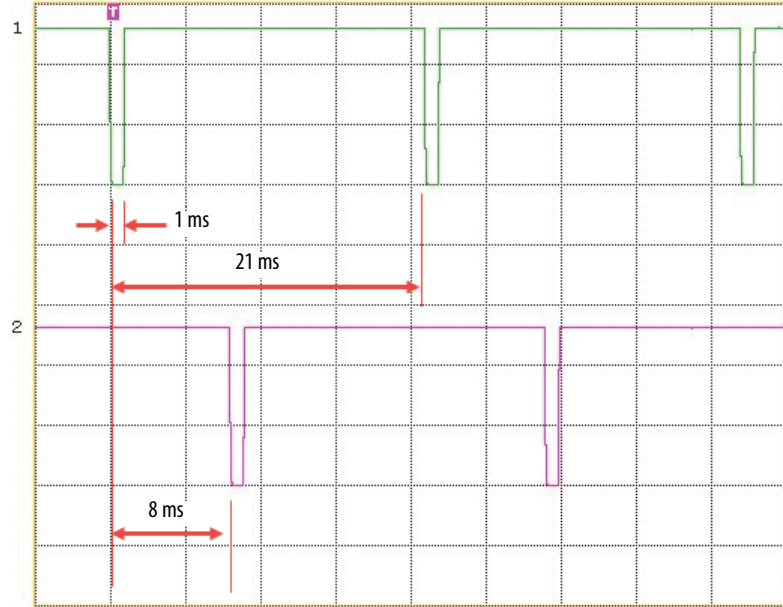

Opto-link Communications

Optical Bus

The GSR family of relays use an optical bus to communicate status information to the 440R-ENETR Guardmaster Ethernet/IP network interface⁽¹⁾. DG safety relays have two optical buses:

- Bus 2 allows communication to pass from the 440R-ENETR interface to the DI, DIS, EM, EMD, GLP, GLT, and SI safety relays (the CI safety relay does not have an optical bus).
- Bus 3 is used exclusively by the DG safety relay for GuardLink communications.

The optical bus ports are on each side of the housing, as shown in [Figure 41](#).

Figure 41 - Optical Bus Ports

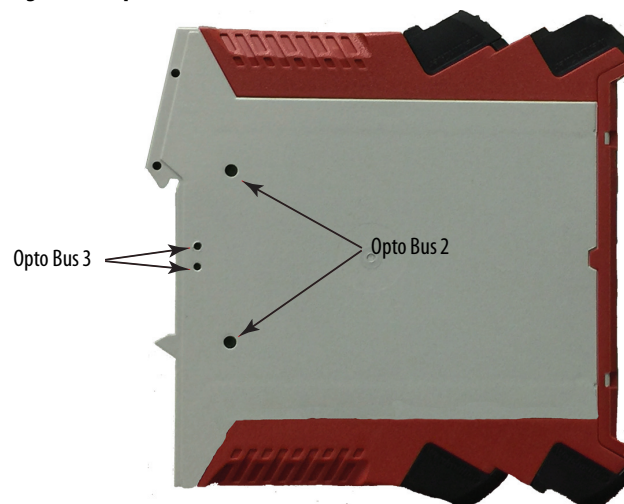

(1) See publication [440R-UM009](#) for detailed 440R-ENETR interface information.

Arrangement with 440R-ENETR Interface

Each 440R-ENETR interface can communicate with up to six GSR relays, in any combination. All DG safety relays must be located closest to the 440R-ENETR interface, as shown in [Figure 42](#).

Figure 42 - 440R-ENETR Interface Arrangement

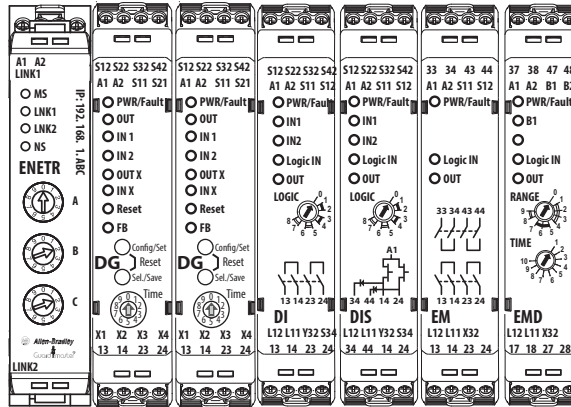

The 440R-ENETR interface can monitor up to six relays of any combination. The DG safety relays must be closest to the 440R-ENETR interface. → ← 5 mm (0.2 in.) max spacing between relays

The DG safety relay requires a 440R-ENETR interface when controlling guard locking interlock switches on a GuardLink circuit. An Ethernet interface is also useful, but not required, when monitoring guarding interlocks and E-stop devices. Status and fault codes can be transferred from the DG safety relay to the machine controller and control signals can be sent from the machine controller to the DG safety relay.

The status signals from the DG safety relay to the machine controller include:

- Status of the DG safety relay terminals
- Status of the taps on the GuardLink circuits
- Fault codes of the DG safety relay or the taps.

The control signals from the machine controller to the DG safety relay include:

- Reset command to turn on the DG safety relay outputs if the inputs are satisfied.
- Lock and unlock commands to lock or unlock the guard locking interlocks.
- Fault reset to cycle power to the DG relay to clear certain faults.

Tap fault reset to cycle power to the device connected to the tap to clear certain faults.

See publication [440R-UM009](#) for details.

Safety Function Calculations

GuardLink System

The GuardLink system typically consists of multiple taps and input devices. When calculating the Performance Level or the safety integrity level, the safety function must only consider the input device, the associated tap, the DG and EM safety relays, and the output devices driven by the safety relays. [Figure 43](#) shows an example safety system to help demonstrate the process of determining the Performance Level.

Figure 43 - Example Circuit for Safety System Calculation

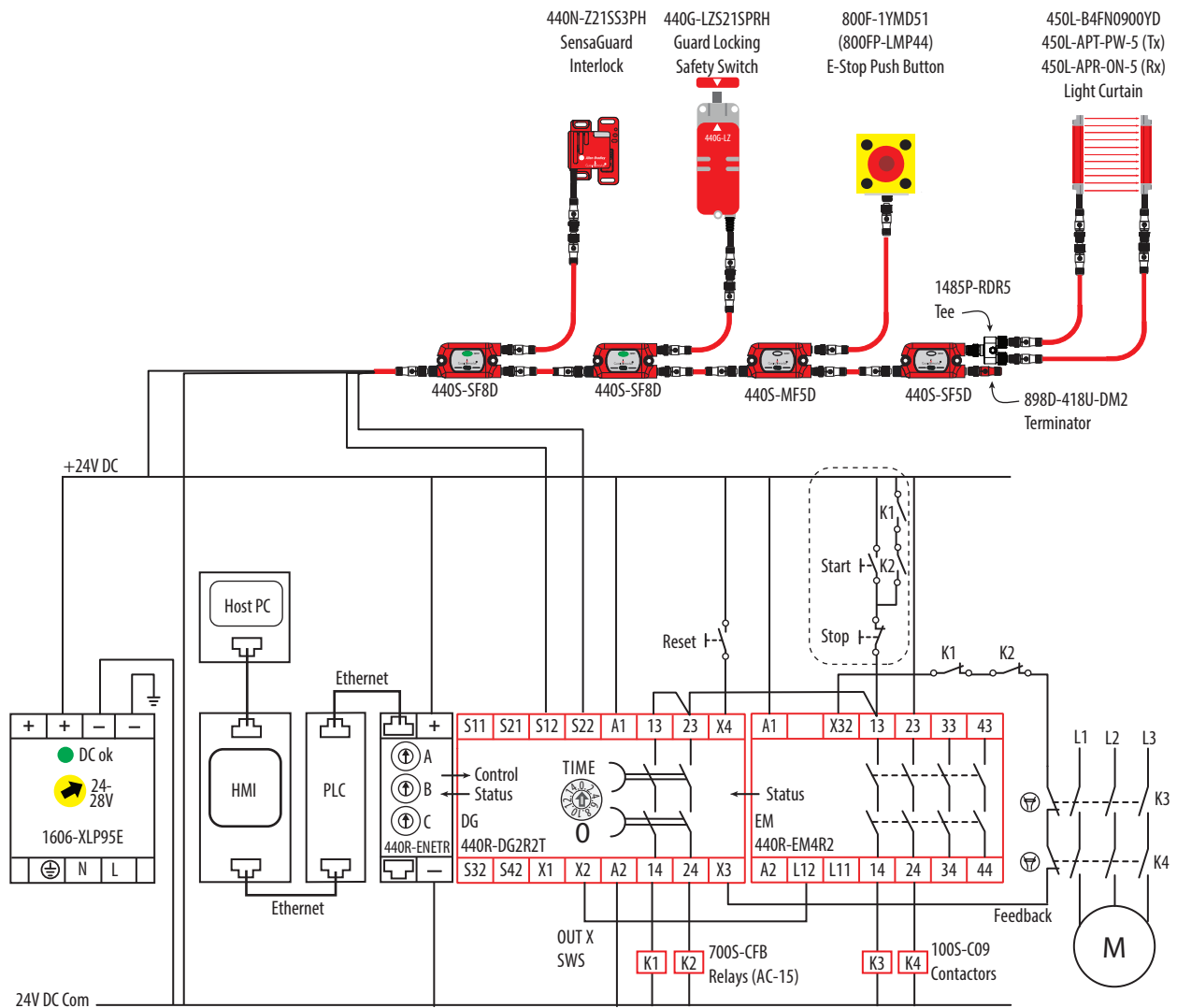

This system has eight safety functions; two functions for each input device. One function is for the DG outputs, and the second is for the expansion module outputs. The safety Function Block Diagrams are shown in [Figure 44](#).

Figure 44 - Safety Function Block Diagrams

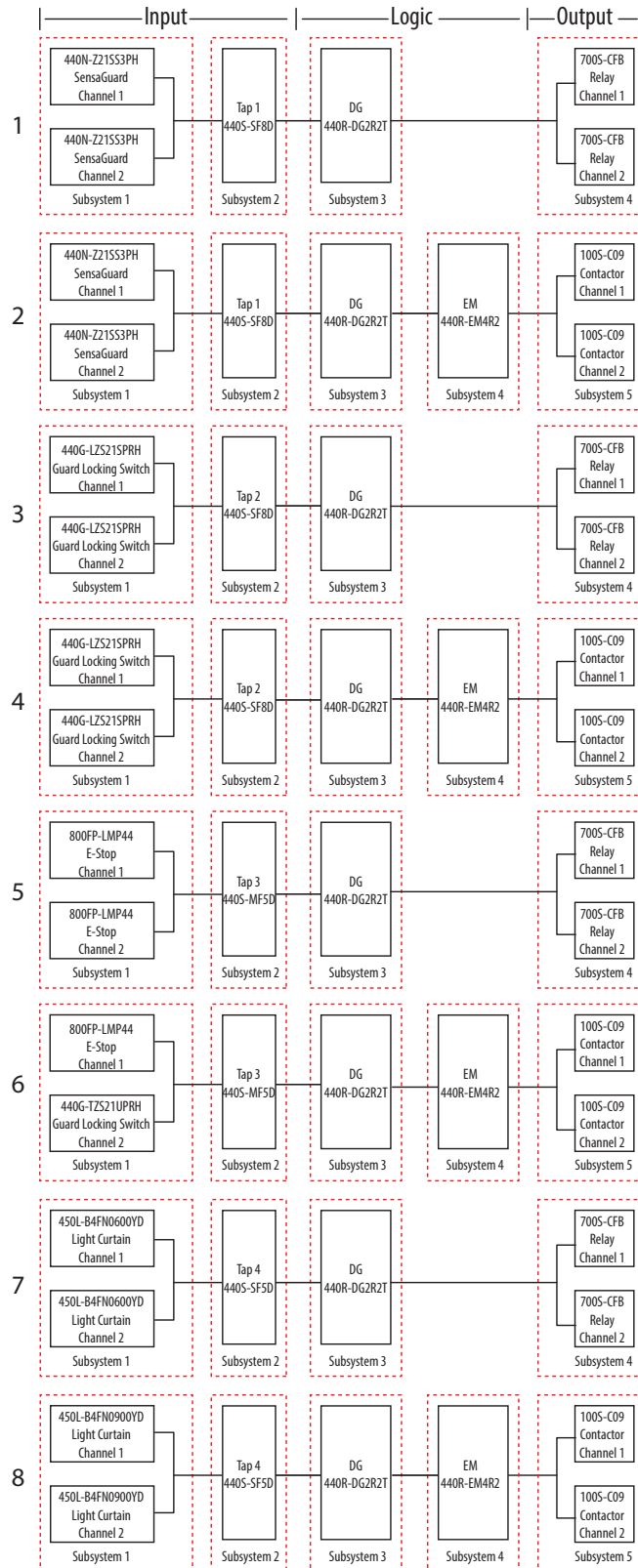

SISTEMA

SISTEMA is a free program that is used to determine the safety function values per ISO 13849. Many devices are preloaded into a Rockwell Automation library. The DG relay and taps were loaded into a local library, based on the safety data in [Appendix C](#). These devices will be available in a future update of the Rockwell Automation library.

[Figure 45](#) shows the first two safety functions. To generate the remaining functions, you can simply copy and paste these functions back into the project and then change the input device.

To achieve a PLe rating and a 20-year mission time, the system is limited to 65,000 operations each year. The limiting component is the 100S contactors, which are driving the motor load. The E-stop has a limitation of 12,000 operations per year.

Figure 45 - SISTEMA Project - First Two Safety Functions

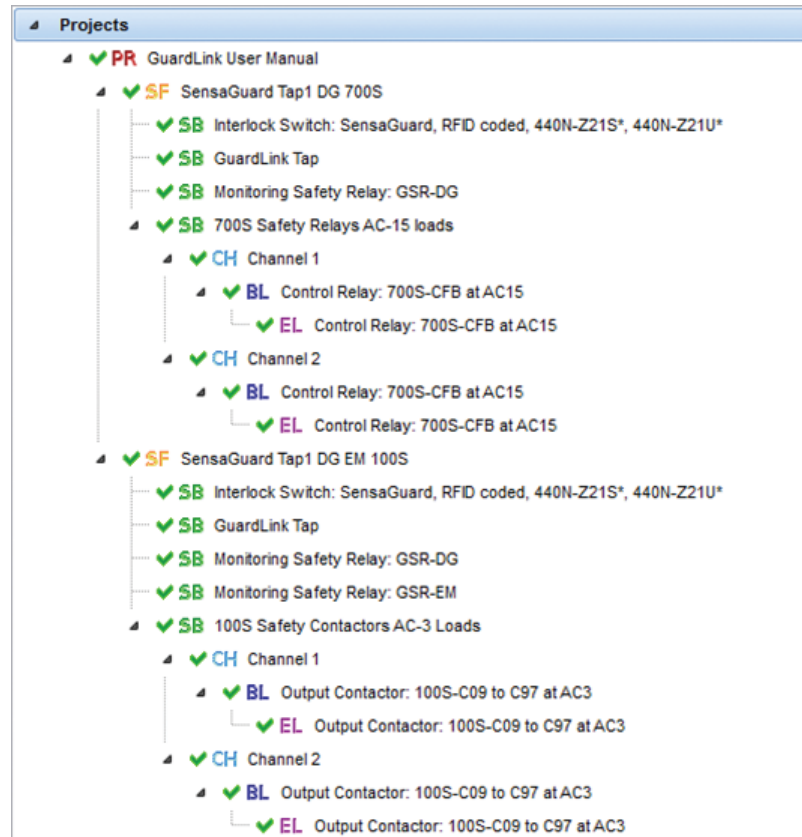

Figure 46 shows a summary of the project. Each safety function has a required Performance Level of “e”, and each safety function has achieved that level.

Figure 46 - Project Summary

The screenshot shows the SIMEMA Project Summary interface. At the top, there is a header with 'SIMEMA Project'. Below this, there are two tabs: 'Documentation' and 'Safety functions'. The 'Safety functions' tab is active. On the left side, there is a sidebar with three options: 'New', 'Edit', and 'Delete'. The main area displays a table with the following data:

Status	Name	Type	PLr	PL
✔ SF	SensaGuard Tap1 DG 700S		e	e
✔ SF	SensaGuard Tap1 DG EM 100S		e	e
✔ SF	440G-LZ Tap2 DG 700S		e	e
✔ SF	440G-LZ Tap2 DG EM 100S		e	e
✔ SF	E-stop Tap3 DG 700S		e	e
✔ SF	E-stop Tap3 DG EM 100S		e	e
✔ SF	LightCurtain Tap4 DG 700S		e	e
✔ SF	Light Curtain Tap4 DG EM 100S		e	e

Specifications

DG Safety Relay

Table 14 - General Specifications — DG Safety Relay

Attribute	440R-DG2R2T
Dimensions, H x W x D	119.14 x 22.5 x 113.6 mm (6.49 x 0.88 x 4.47 in.)
Shipping weight, approx.	225 g (0.5 lb)
Wire size	0.2...2.5 mm ² (24...14 AWG)
Wiring category	Copper that withstands 75 °C (167 °F)
Insulation stripping length	7 mm (0.28 in.)
Terminal screw torque	0.4 N·m (4 lb·in)
Power supply voltage range	24V DC PELV/SELV, UL Class 1 Div. 2., 0.85...1.1 x rated voltage
Power consumption	3.5 W
Power on delay	5.5 s
Case material	Polyamide PA 6.6
Terminal protection	IP20
Enclosure protection	IP40 (NEMA 1)
Mounting	35 mm (1.4 in.) DIN rail in enclosure that is rated to a minimum of IP54

Table 15 - Environmental Specifications — DG Safety Relay

Attribute	440R-DG2R2T
Temperature, operating	-5...+55 °C (23...131 °F)
Relative humidity	90%
Vibration	10...55 Hz, 0.35 mm
Shock	10 g, 16 ms
Pollution level	2
Installation group	Overvoltage Category III, VDE 0110-1
Impulse withstand voltage	2500V

Table 16 - Pulse Test Output Specifications — DG Safety Relay

Attribute	440R-DG2R2T
Wiring terminals	S11/S21
Continuous output current, max	100 mA
Surge output current, max	0.7 A
Surge output current duration, max	5 ms
Residual voltage drop from P/S, max	0.6V
Load capacitance, max [nF/mA load]	200/20 100/10 22/0
Off state leakage current, max	< 0.1 mA
Short circuit detection	Yes
Short circuit protection	Yes
Galvanic isolation: I/O from logic	No
Pulse test duration	≤700 μs
Pulse test period	5 ms

Table 17 - Input Devices with Voltage-free Contacts Specifications — DG Safety Relay

Attribute	440R-DG2R2T
Wiring terminals	S12/S22 and S32/S42
ON voltage, max	26.4V
ON voltage, min	11V
OFF voltage, max	5V
OFF current, max	2 mA
ON current, min at 20V DC	10 mA
Galvanic isolation: I/O from logic	No
Off pulse that is accepted for OSSD setting without declaring the input as OFF	Min = 0 μs Max = 700μs
Off pulse period, min	15 ms
Input capacitance	220 nF

Table 18 - SWS Specifications — DG Safety Relay

Attribute	440R-DG2R2T
Wiring terminal	Output - X2 Input - X1
Continuous output current, max	50 mA
ON state voltage drop (P/S to +), max	0.2V
Surge output current, max	700 mA
Surge output current duration, max	5 ms
Load capacitance, max	1 μ F
Off state leakage current, max	< 0.1 mA
Short circuit detection	No
Short circuit protection	Yes
Galvanic isolation: I/O from logic	No
Fan-out (Max number of connections to L11)	10
Cable length between L11 and L12	30 m (98.4 ft)
Off state leakage current, max	< 0.1 mA
Short circuit detection	Yes
Short circuit protection	Yes

Table 19 - Safety Output Specifications — DG Safety Relay

Attribute	440R-DG2R2T
Wiring terminals	13/14, 23/24
Types	2 N.O.
Thermic current I_{th}	1 x 6 A
Fuses output (external)	6 A slow blow or 10 A quick blow
Switched current, min	10 mA
Switched voltage, min	10V
Mechanical life	10,000,000 cycles
Rating	UL:C300 AC-15:1.5 A / 250V AC DC13: 2 A / 24V DC (0.1 Hz)
Contact material	AgNi + 0.2 μ Au
Reaction times	
Automatic reset	<100 ms
Monitored manual reset	<500 ms
Response time	
13/14 and 23/24 safety outputs	35 ms
SWS output	30 ms
Recovery time	100 ms

Tap

Table 20 - General Specifications — Tap

Attribute	440S-SF8D, 440S-SF5D, 440S-MF5D, 440S-MF8D
Dimensions, L x W x H	79.64 x 38.5 x 17 mm (3.14 x 1.51 x 0.67 in.)
Shipping weight, approx.	27.2 g (0.96 oz)
Case material	Red RAL 3020 unfilled ABS MG47C plastic
Mounting screw torque	2.25 N•m (20 lb•in)
Mounting	Any orientation

Table 21 - Electrical Specifications — Tap

Attribute	440S-SF8D, 440S-SF5D, 440S-MF5D, 440S-MF8D
Voltage requirements	24V DC +10%, -15%
Supply over voltage protection, Max	60V DC
Reverse polarity protection	Yes
Short circuit protection	
OSSD supply and lock signal	700 mA
GuardLink signals	500 mA
ON voltage, max	26.4V
ON voltage, min	11V
OFF voltage, max	5V
OFF current, max	2 mA
ON current, min at 20V DC	10 mA
Galvanic isolation: I/O from logic	No
Off pulse that is accepted for OSSD setting without declaring the input as OFF	Min = 0 μ s Max = 700 μ s
Off pulse period, min	15 ms
Input capacitance	220 nF
Current consumption	
EMSS input ON	40 mA
EMSS input OFF	25 mA
OSSD input ON	29 mA
OSSD input OFF	25 mA
Voltage that is supplied to OSSD device connected to the J3 connector	
Pin 1 of 5-pin OSSD	J1 supply voltage -1.2V @ 500 mA, max load, 0.4V at 50 mA load
Pin 2 of 8-pin OSSD	J1 supply voltage -1.2V @ 500 mA, max load, 0.4V at 50 mA load
Response Time	
EMSS SmartTap	5 ms plus 35 μ s for each upstream tap
OSSD SmartTap	
CLU timing between successive lock/unlock	135...300 ms

Table 22 - Environmental Specifications — Tap and Terminator

Attribute	Tap: 440S-SF8D, 440S-SF5D, 440S-MF5D, 440S-MF8D Terminator: 898D-418U-DM2
Temperature	
Operating	-25...+70 °C (-13...+158 °F)
Storage	-40...+85 °C (-40...+185 °F)
Relative humidity	35...85%, not exceed 50%RH at 70 °C (158 °F)
Vibration per IEC 60068-2-6	10...55 Hz, 1 mm
Shock per IEC 60068-2-27	30 g, 11 ms, half-sine
Pollution level per IEC 60947-5-2	3
Enclosure protection	IP65, IP67 washdown according to EN 60529, UL Type 1 PR61413
Flammability	UL94, DIN 752000/FMV 55302
Protection against electric shock	Class III per EN 61140
Emissions	CISPR 11

Notes:

Configuration Examples

This appendix contains examples of configurations. Each example contains the following:

- Schematic

This diagram shows the major connections. The input devices are not shown because of multiple configuration options.

- Logic diagram

This diagram shows the safety monitoring function (SMF), the logic level, and the safety output function (SOF).

- Configuration table

This table shows potential examples of configuration for the corresponding schematic and logic diagram. Each configuration also shows the color of the status indicators during configuration. If in Run mode, a short press of the Config/Set button also shows these indicators.

Configuration 1

In Configuration 1, both safety inputs, Input 1 and Input 2, are in use. They can either be configured for GuardLink or OSSD with autodetect of EMSS devices. Input devices are not shown in the drawing.

The input IN X (terminal X1) is configured for SWS In; this input is ANDed with IN 1 and IN 2.

The output OUT X (terminal X2) is configured for SWS Out and can drive any other SWS compatible device. In this example, the SWS out is driving an EM safety relay. OUT X is switched off immediately when demanded by the safety functions. The relay outputs 14/24 can be configured for a time delay to switch off after the delay time.

The relay configuration is considered a middle SWS as it requires an SWS input and provides an SWS output.

The Reset mode is configured for manual monitored reset and is assigned to the safety outputs. The outputs are enabled when all inputs of the safety function are ACTIVE, the feedback signal is present, and a valid reset operation has been performed.

Figure 47 - Two Safety Inputs, Middle SWS, and Monitored Manual Reset Assigned to Safety Outputs Schematic

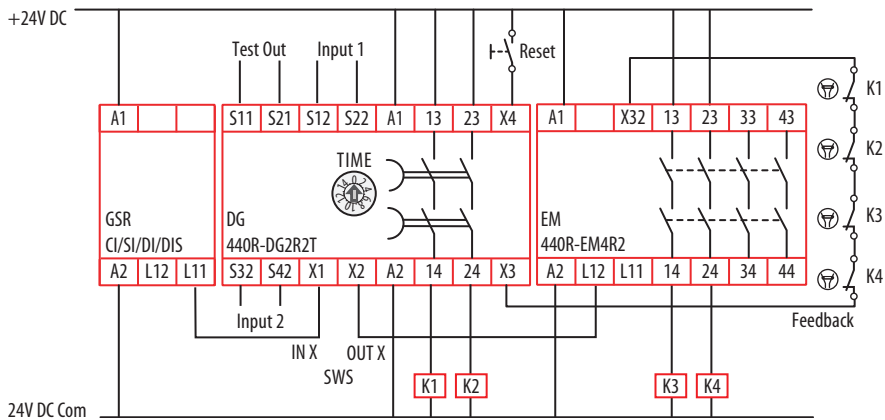

Logic

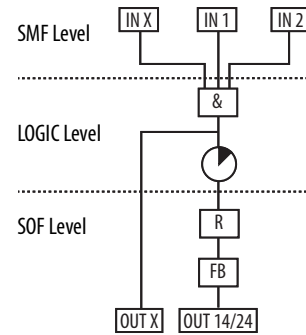

Table 23 - Configuration 1 — Hex (Dec)

Indicator	Function	Configuration ID: 0x7F (127)	Configuration ID: 0x7B (123)	Configuration ID: 0x7D (125)	Configuration ID: 0x79 (121)
OUT	Safety Functions	● IN1 and IN2	● IN1 and IN2	● IN1 and IN2	● IN1 and IN2
IN 1	Input Type	● GuardLink	● GuardLink	● OSSD/EMSS	● OSSD/EMSS
IN 2	Input Type	● GuardLink	● OSSD/EMSS	● GuardLink	● OSSD/EMSS
OUT X	Output Type	● SWS	● SWS	● SWS	● SWS
IN X	Input Mode	● SWS Enabled	● SWS Enabled	● SWS Enabled	● SWS Enabled
Reset	Reset Type	● Monitored Manual	● Monitored Manual	● Monitored Manual	● Monitored Manual
FB	Reset Assignment	● SOF	● SOF	● SOF	● SOF

Configuration 2

In Configuration 2, both safety inputs, Input 1 and Input 2, are in use. They can either be configured for GuardLink or OSSD with autodetect of EMSS devices. Input devices are not shown in the drawing.

The input IN X (terminal X1) is configured for SWS In. This input is ANDed with IN 1 and IN 2.

The output OUT X (terminal X2) is configured for SWS Out and can drive any other SWS compatible device. In this example, the SWS out is driving an EM safety relay. OUT X is switched off immediately when demanded by the safety functions. The relay outputs 14/24 can be configured for a time delay to switch off after the delay time.

The relay configuration is considered a middle SWS as it requires an SWS input and provides an SWS output.

The Reset mode is configured for manual monitored reset that is assigned to Input 1. After a demand of the safety function by Input 1, the outputs are enabled when all safety inputs are ACTIVE, the feedback signal is present, and a valid reset operation has been performed.

After a demand of the safety function by Input 2 or IN X, the outputs are enabled when the IN 2 and IN X safety inputs are ACTIVE and the feedback signal is present. A reset operation is not required.

Figure 48 - Two Safety Inputs, Middle SWS, Monitored Manual Reset Assigned to Input 1, Automatic Reset Assigned to Input 2

Schematic

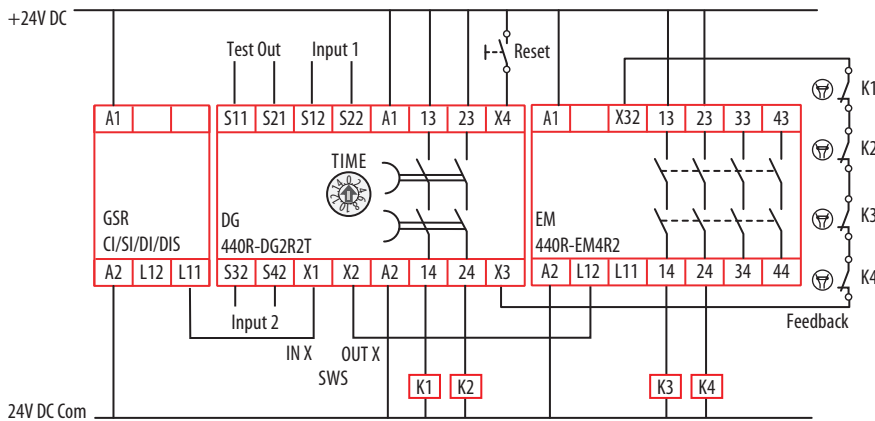

Logic

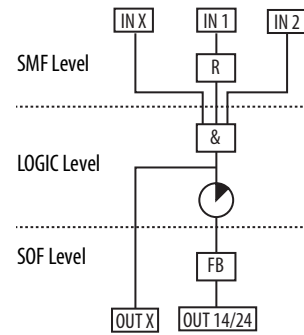

Table 24 - Configuration 2 — Hex (Dec)

Indicator	Function	Configuration ID: 0x3F (63)	Configuration ID: 0x3B (59)	Configuration ID: 0x3D (61)	Configuration ID: 0x39 (57)
OUT	Safety Functions	● IN1 and IN2	● IN1 and IN2	● IN1 and IN2	● IN1 and IN2
IN 1	Input Type	● GuardLink	● GuardLink	● OSSD/EMSS	● OSSD/EMSS
IN 2	Input Type	● GuardLink	● OSSD/EMSS	● GuardLink	● OSSD/EMSS
OUT X	Output Type	● SWS	● SWS	● SWS	● SWS
IN X	Input Mode	● SWS Enabled	● SWS Enabled	● SWS Enabled	● SWS Enabled
Reset	Reset Type	● Monitored Manual	● Monitored Manual	● Monitored Manual	● Monitored Manual
FB	Reset Assignment	● SMF IN1	● SMF IN1	● SMF IN1	● SMF IN1

Configuration 3

In Configuration 3, both safety inputs, Input 1 and Input 2, are in use. They can either be configured for GuardLink or OSSD with autodetect of EMSS devices. Input devices are not shown in the drawing.

The input IN X (terminal X1) is configured for SWS In. This input is ANDed with IN 1 and IN 2.

The output OUT X (terminal X2) is configured for SWS Out and can drive any other SWS compatible device. In this example, the SWS out is driving an EM safety relay. OUT X is switched off immediately when demanded by the safety functions. The relay outputs 14/24 can be configured for a time delay to switch off after the delay time.

The relay configuration is considered a middle SWS as it requires an SWS input and provides an SWS output.

The Reset mode is configured for automatic and assigned to the safety outputs. After a demand of the safety function by any input, the outputs are enabled when all safety inputs are ACTIVE and the feedback signal is present. A reset operation is not required.

Figure 49 - Two Safety Inputs, Middle SWS, Automatic Reset Assigned to Safety Outputs Schematic

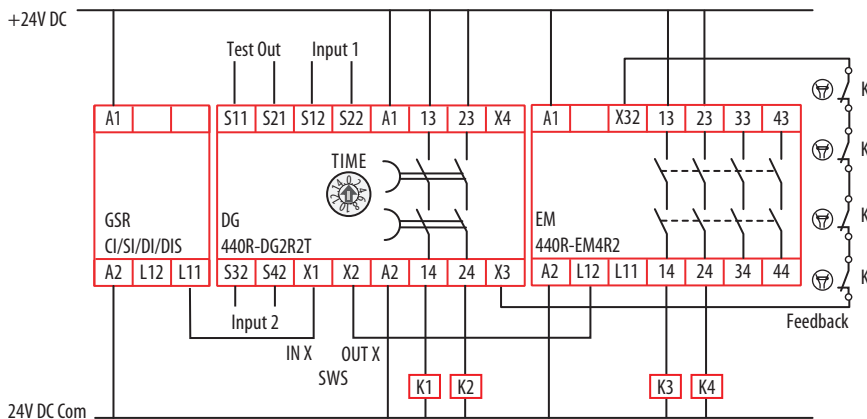

Logic

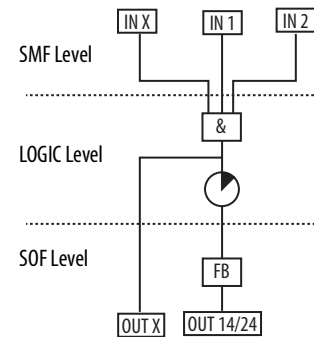

Table 25 - Configuration 3 — Hex (Dec)

Indicator	Function	Configuration ID: 0x1F (31)	Configuration ID: 0x1B (27)	Configuration ID: 0x1D (29)	Configuration ID: 0x19 (25)
OUT	Safety Functions	● IN1 and IN2	● IN1 and IN2	● IN1 and IN2	● IN1 and IN2
IN 1	Input Type	● GuardLink	● GuardLink	● OSSD/EMSS	● OSSD/EMSS
IN 2	Input Type	● GuardLink	● OSSD/EMSS	● GuardLink	● OSSD/EMSS
OUT X	Output Type	● SWS	● SWS	● SWS	● SWS
IN X	Input Mode	● SWS Enabled	● SWS Enabled	● SWS Enabled	● SWS Enabled
Reset	Reset Type	● Automatic	● Automatic	● Automatic	● Automatic
FB	Reset Assignment	● Not used	● Not used	● Not used	● Not used

Configuration 4

In Configuration 4, only safety Input 1 is in use. It can either be configured for GuardLink or OSSD with autodetect of EMSS devices. Input devices are not shown in the drawing.

The input IN X (terminal X1) is configured for SWS In. This input is ANDed with IN 1.

The output OUT X (terminal X2) is configured for SWS Out and can drive any other SWS compatible device. In this example, the SWS out is driving an EM safety relay. OUT X is switched off immediately when demanded by the safety functions. The relay outputs 14/24 can be configured for a time delay to switch off after the delay time.

The relay configuration is considered a middle SWS as it requires an SWS input and provides an SWS output.

The Reset mode is configured for manual monitored reset and is assigned to the safety outputs. The outputs are enabled when all inputs of the safety function are ACTIVE, the feedback signal is present, and a valid reset operation has been performed.

Figure 50 - One Safety Input, Middle SWS, Monitored Manual Reset Assigned to Safety Outputs Schematic

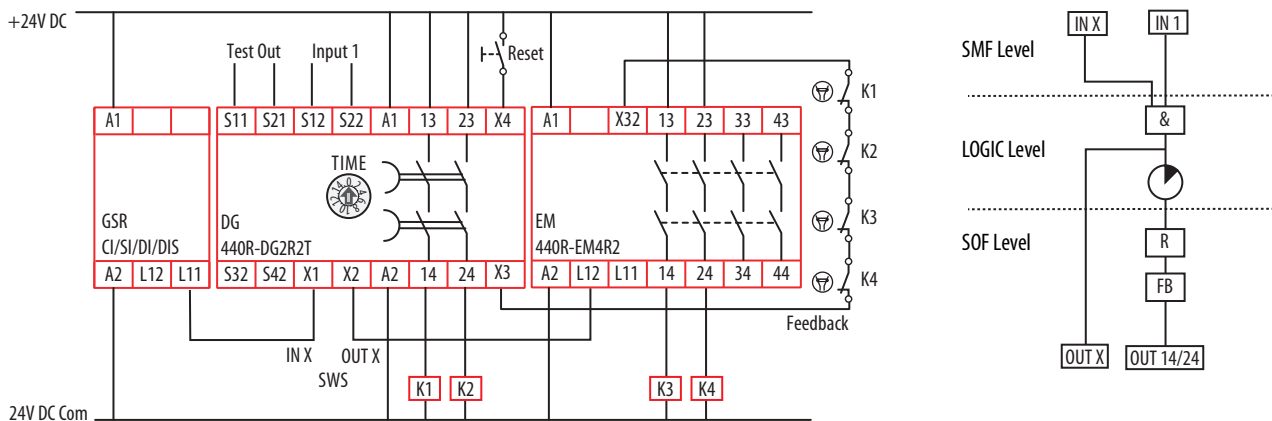

Table 26 - Configuration 4 — Hex (Dec)

Indicator	Function	Configuration ID: 0x7A (122)	Configuration ID: 0x78 (120)
OUT	Safety Functions	● IN1	● IN1
IN 1	Input Type	● GuardLink	● OSSD/EMSS
IN 2	Input Type	● Not used	● Not used
OUT X	Output Type	● SWS	● SWS
IN X	Input Mode	● SWS Enabled	● SWS Enabled
Reset	Reset Type	● Monitored Manual	● Monitored Manual
FB	Reset Assignment	● SOF	● SOF

Configuration 5

In Configuration 5, only safety Input 1 is in use. It can either be configured for GuardLink or OSSD with autodetect of EMSS devices. Input devices are not shown in the drawing.

The input IN X (terminal X1) is configured for SWS In. This input is ANDed with IN 1.

The output OUT X (terminal X2) is configured for SWS Out and can drive any other SWS compatible device. In this example, the SWS out is driving an EM safety relay. OUT X is switched off immediately when demanded by the safety functions. The relay outputs 14/24 can be configured for a time delay to switch off after the delay time.

The relay configuration is considered a middle SWS as it requires an SWS input and provides an SWS output.

The Reset mode is configured for automatic/manual and assigned to the safety outputs. After a demand of the safety function by any input, the outputs are enabled when all safety inputs are ACTIVE and the feedback signal is present. A reset operation is not required.

Figure 51 - One Safety Input, Middle SWS, Automatic Reset Assigned to Safety Outputs Schematic

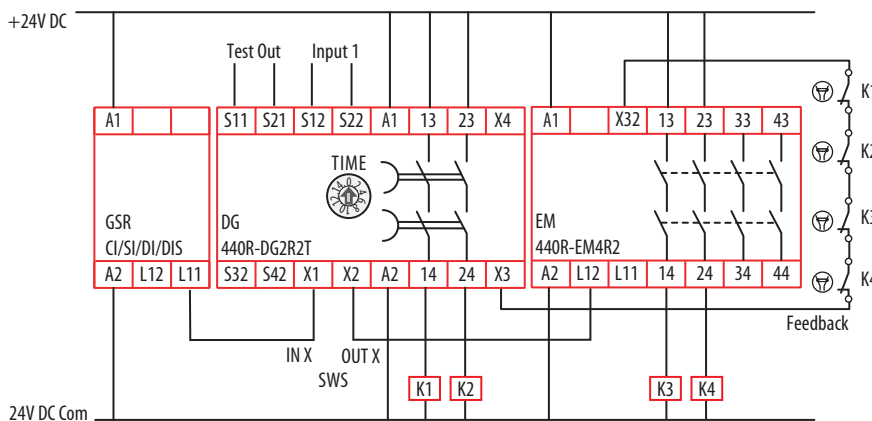

Logic

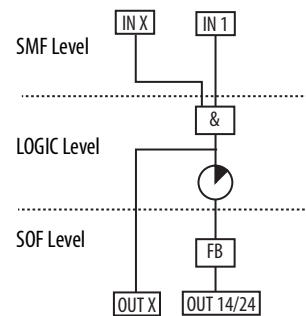

Table 27 - Configuration 5 — Hex (Dec)

Indicator	Function	Configuration ID: 0x1A (26)	Configuration ID: 0x18 (24)
OUT	Safety Functions	● IN1	● IN1
IN 1	Input Type	● GuardLink	● OSSD/EMSS
IN 2	Input Type	● Not used	● Not used
OUT X	Output Type	● SWS	● SWS
IN X	Input Mode	● SWS Enabled	● SWS Enabled
Reset	Reset Type	● Automatic	● Automatic
FB	Reset Assignment	● Not used	● Not used

Configuration 6

In Configuration 6, both safety inputs, Input 1 and Input 2, are in use. They can either be configured for GuardLink or OSSD with autodetect of EMSS devices. Input devices are not shown in the drawing.

The input IN 1 (terminal X1) is disabled; there is no connection to terminal X1.

The output OUT X (terminal X2) is configured for SWS Out. SWS Out can drive any other SWS compatible device. In this example, the SWS out is driving an EM safety relay. OUT X is switched off immediately when demanded by the safety functions. The relay outputs 14/24 can be configured for a time delay to switch off after the delay time.

The relay configuration is considered a first SWS as it does not require SWS input and provides an SWS output.

The Reset mode is configured for manual monitored reset and is assigned to the safety outputs. The outputs are enabled when all safety inputs are ACTIVE, the feedback signal is present, and a valid reset operation has been performed.

Figure 52 - Two Safety Inputs, First SWS Device, Manual Monitored Reset Assigned to Safety Outputs Schematic

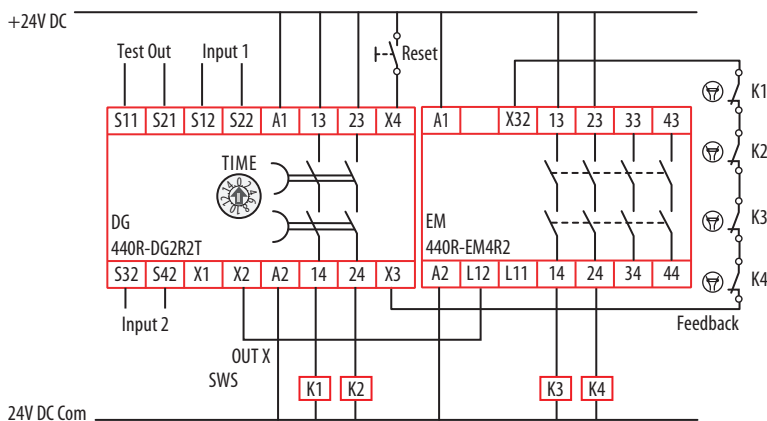

Logic

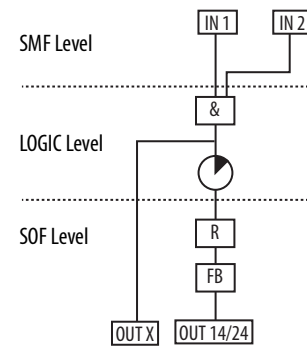

Table 28 - Configuration 6 — Hex (Dec)

Indicator	Function	Configuration ID: 0x6F (111)	Configuration ID: 0x6B (107)	Configuration ID: 0x6D (109)	Configuration ID: 0x69 (105)
OUT	Safety Functions	● IN1 and IN2	● IN1 and IN2	● IN1 and IN2	● IN1 and IN2
IN 1	Input Type	● GuardLink	● GuardLink	● OSSD/EMSS	● OSSD/EMSS
IN 2	Input Type	● GuardLink	● OSSD/EMSS	● GuardLink	● OSSD/EMSS
OUT X	Output Type	● SWS	● SWS	● SWS	● SWS
IN X	Input Mode	● Disabled	● Disabled	● Disabled	● Disabled
Reset	Reset Type	● Monitored Manual	● Monitored Manual	● Monitored Manual	● Monitored Manual
FB	Reset Assignment	● SOF	● SOF	● SOF	● SOF

Configuration 7

In Configuration 7, both safety inputs, Input 1 and Input 2, are in use. They can either be configured for GuardLink or OSSD with autodetect of EMSS devices. Input devices are not shown in the drawing.

The input IN 1 (terminal X1) is disabled; there is no connection to terminal X1.

The output Out X (terminal X2) is configured for SWS Out. SWS Out can drive any other SWS compatible device. In this example, the SWS out is driving an EM safety relay. Output Out X is switched off immediately when demanded by the safety functions. The relay outputs 14/24 can be configured for a time delay to switch off after the delay time.

The Reset mode is configured for manual monitored reset and is assigned to Input 1. After a demand of the safety function by Input 1, the outputs are enabled when all safety inputs are ACTIVE, the feedback signal is present, and a valid reset operation has been performed.

After a demand of the safety function by Input 2, the outputs are enabled when all safety inputs are ACTIVE and the feedback signal is present. A reset operation is not required.

Figure 53 - Two Safety Inputs, First SWS Device, Monitored Manual Reset Assigned to Input 1, Automatic Reset Assigned to Input 2

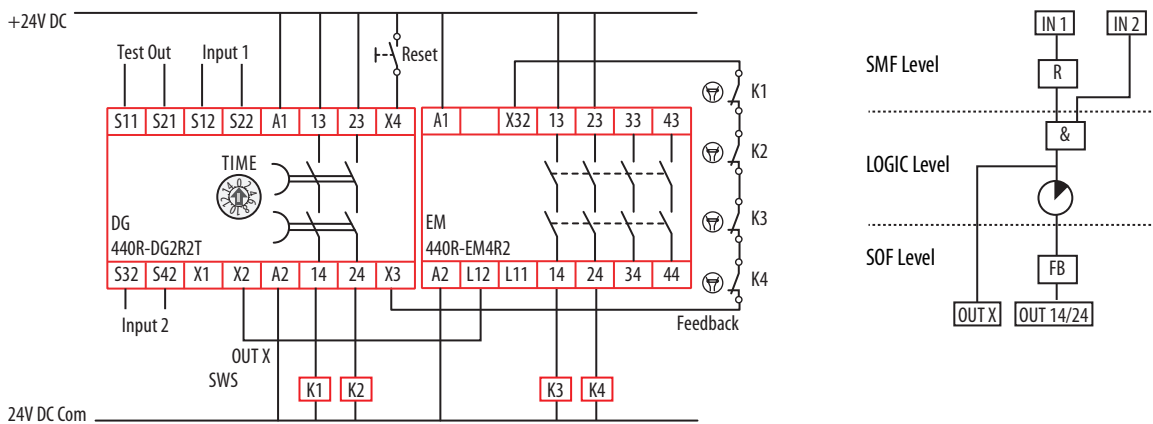

Table 29 - Configuration 7 — Hex (Dec)

Indicator	Function	Configuration ID: 0x2F (47)	Configuration ID: 0x2B (43)	Configuration ID: 0x2D (45)	Configuration ID: 0x29 (41)
OUT	Safety Functions	● IN1 and IN2	● IN1 and IN2	● IN1 and IN2	● IN1 and IN2
IN 1	Input Type	● GuardLink	● GuardLink	● OSSD/EMSS	● OSSD/EMSS
IN 2	Input Type	● GuardLink	● OSSD/EMSS	● GuardLink	● OSSD/EMSS
OUT X	Output Type	● SWS	● SWS	● SWS	● SWS
IN X	Input Mode	● Disabled	● Disabled	● Disabled	● Disabled
Reset	Reset Type	● Monitored Manual	● Monitored Manual	● Monitored Manual	● Monitored Manual
FB	Reset Assignment	● SMF IN1	● SMF IN1	● SMF IN1	● SMF IN1

Configuration 8

In Configuration 8, both safety inputs, Input 1 and Input 2, are in use. They can either be configured for GuardLink or OSSD with autodetect of EMSS devices. Input devices are not shown in the drawing.

The input IN 1 (terminal X1) is disabled; there is no connection to terminal X1.

The output Out X (terminal X2) is configured for SWS Out. SWS Out can drive any other SWS compatible device. In this example, the SWS out is driving an EM safety relay. Output Out X is switched off immediately when demanded by the safety functions. The relay outputs 14/24 can be configured for a time delay to switch off after the delay time.

The relay configuration is considered a first SWS as it does not require SWS input and provides an SWS output.

The Reset mode is configured for automatic manual and assigned to the safety outputs. After a demand of the safety function by any input, the outputs are enabled when all safety inputs are ACTIVE and the feedback signal is present. A reset operation is not required.

Figure 54 - First SWS Device, Two Safety Inputs, Automatic Restart Assigned to Safety Outputs

Schematic

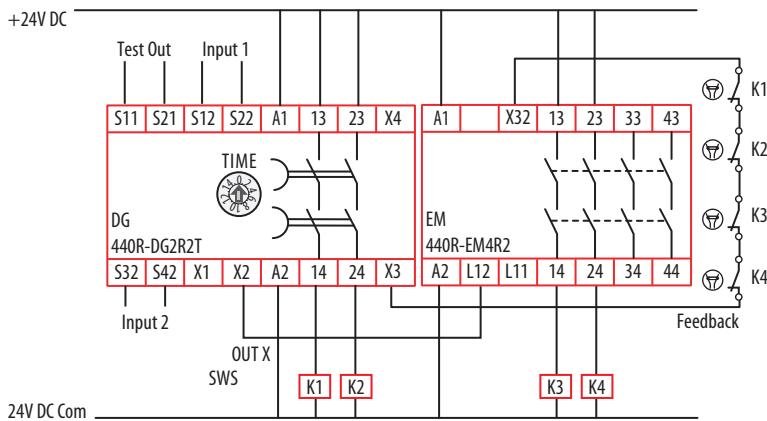

Logic

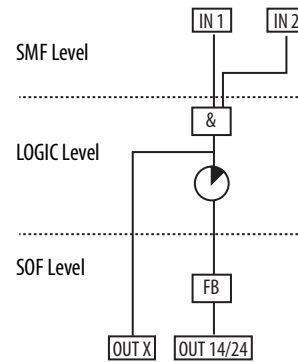

Table 30 - Configuration 8 — Hex (Dec)

Indicator	Function	Configuration ID: 0x0F (15)	Configuration ID: 0x0B (11)	Configuration ID: 0x0D (13)	Configuration ID: 0x09 (9)
OUT	Safety Functions	● IN1 and IN2	● IN1 and IN2	● IN1 and IN2	● IN1 and IN2
IN 1	Input Type	● GuardLink	● GuardLink	● OSSD/EMSS	● OSSD/EMSS
IN 2	Input Type	● GuardLink	● OSSD/EMSS	● GuardLink	● OSSD/EMSS
OUT X	Output Type	● SWS	● SWS	● SWS	● SWS
IN X	Input Mode	● SWS Enabled	● SWS Enabled	● SWS Enabled	● SWS Enabled
Reset	Reset Type	● Automatic	● Automatic	● Automatic	● Automatic
FB	Reset Assignment	● Not used	● Not used	● Not used	● Not used

Configuration 9

In Configuration 9, only safety Input 1 is in use. It can either be configured for GuardLink or OSSD with autodetect of EMSS devices. Input devices are not shown in the drawing.

The input IN 1 (terminal X1) is disabled; there is no connection to terminal X1.

The output Out X (terminal X2) is configured for SWS Out. SWS Out can drive any other SWS compatible device. In this example, the SWS out is driving an EM safety relay. Output Out X is switched off immediately when demanded by the safety functions. The relay outputs 14/24 can be configured for a time delay to switch off after the delay time.

The relay configuration is considered a first SWS as it does not require SWS input and provides an SWS output.

The Reset mode is configured for manual monitored reset and is assigned to the safety outputs. The outputs are enabled when all inputs of the safety function are ACTIVE, the feedback signal is present, and a valid reset operation has been performed.

Figure 55 - One Safety Input, First SWS, Monitored Manual Reset Assigned to Safety Outputs Schematic

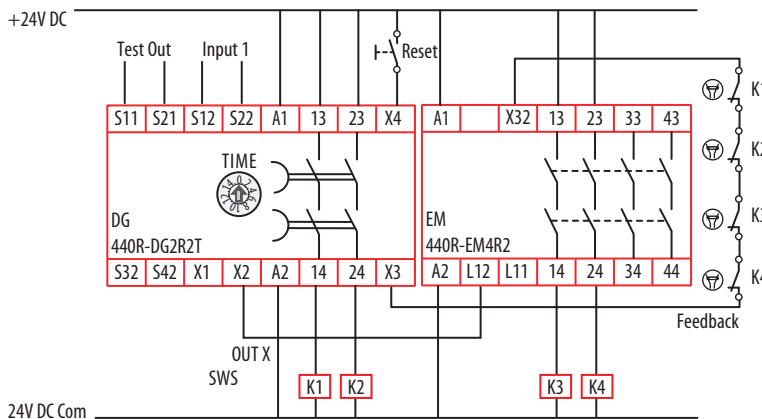

Logic

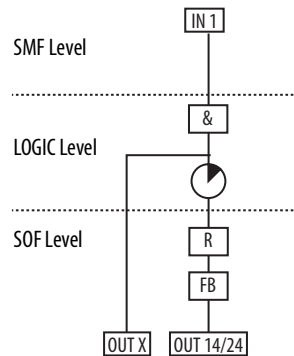

Table 31 - Configuration 9 — Hex (Dec)

Indicator	Function	Configuration ID: 0x6A (106)		Configuration ID: 0x68 (104)	
		Hex	Dec	Hex	Dec
OUT	Safety Functions	●	IN1	●	IN1
IN 1	Input Type	●	GuardLink	●	OSSD/EMSS
IN 2	Input Type	●	Not used	●	Not used
OUT X	Output Type	●	SWS	●	SWS
IN X	Input Mode	●	SWS Disabled	●	SWS Disabled
Reset	Reset Type	●	Monitored Manual	●	Monitored Manual
FB	Reset Assignment	●	SOF	●	SOF

Configuration 10

In Configuration 10, only safety Input 1 is in use. It can either be configured for GuardLink or OSSD with autodetect of EMSS devices. Input devices are not shown in the drawing.

The input IN 1 (terminal X1) is disabled; there is no connection to terminal X1.

The output Out X (terminal X2) is configured for SWS Out. SWS Out can drive any other SWS compatible device. In this example, the SWS out is driving an EM safety relay. Output Out X is switched off immediately when demanded by the safety functions. The relay outputs 14/24 can be configured for a time delay to switch off after the delay time.

The relay configuration is considered a first SWS as it does not require SWS input and provides an SWS output.

The Reset mode is configured for automatic and assigned to the safety outputs. After a demand of the safety function by any input, the outputs are enabled when all safety inputs are ACTIVE and the feedback signal is present. A reset operation is not required.

Figure 56 - First SWS Device, One Safety Input, Automatic Reset Assigned to Safety Outputs Schematic

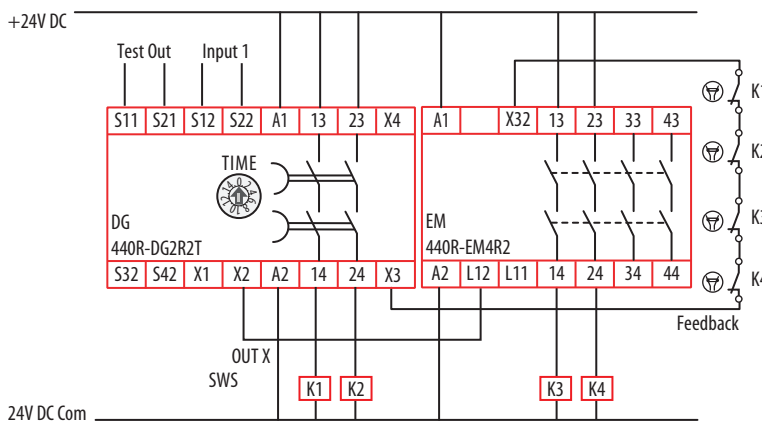

Logic

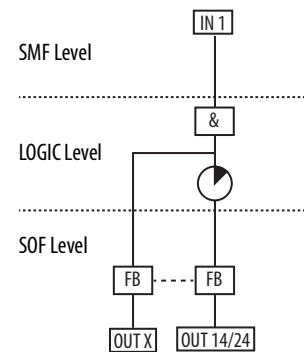

Table 32 - Configuration 10 — Hex (Dec)

Indicator	Function	Configuration ID: 0x0A (10)	Configuration ID: 0x08 (8)
OUT	Safety Functions	● IN1	● IN1
IN 1	Input Type	● GuardLink	● OSSD/EMSS
IN 2	Input Type	● Not used	● Not used
OUT X	Output Type	● SWS	● SWS
IN X	Input Mode	● SWS Disabled	● SWS Disabled
Reset	Reset Type	● Automatic	● Automatic
FB	Reset Assignment	● Not used	● Not used

Configuration 11

In Configuration 11, both safety inputs, Input 1 and Input 2, are in use. They can either be configured for GuardLink or OSSD with autodetect of EMSS devices. Input devices are not shown in the drawing.

The output type for OUT X (terminal X2) is configured for OSSD, and input IN X (terminal X1) is enabled. In this mode, IN X accepts a 24V DC input signal and output OUT X can be used as an immediate switching safety output to initiate a stop function of a drive. The 2-channel safety output 14/24 can drive the safety circuit for a Safe Torque Off with a delay time to perform a Stop Category 1 function.

The Reset mode is configured for manual monitored reset and is assigned to the safety outputs. The outputs are enabled when all inputs of the safety function are ACTIVE, the feedback signal is present, and a valid reset operation has been performed.

Figure 57 - Two Safety Inputs, No SWS, Monitored Manual Assigned to Safety Outputs Schematic

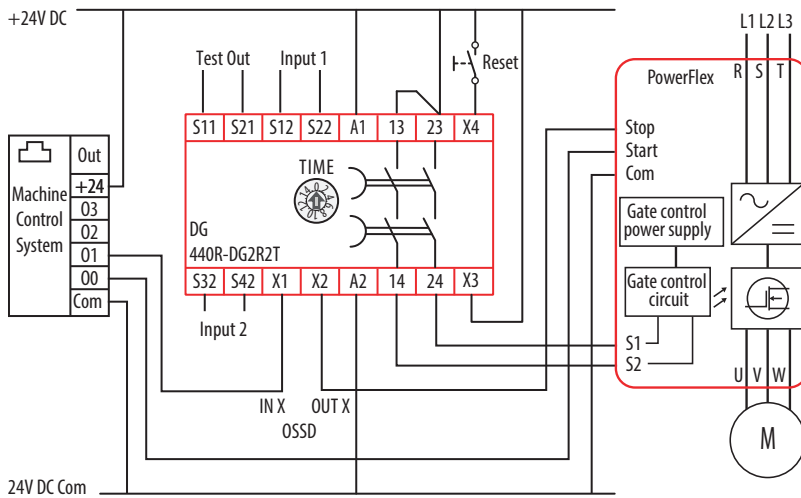

Logic

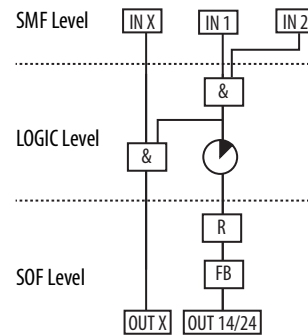

Table 33 - Configuration 11 — Hex (Dec)

Indicator	Function	Configuration ID: 0x77 (119)	Configuration ID: 0x73 (115)	Configuration ID: 0x75 (117)	Configuration ID: 0x71 (113)
OUT	Safety Functions	● IN1 and IN2	● IN1 and IN2	● IN1 and IN2	● IN1 and IN2
IN 1	Input Type	● GuardLink	● GuardLink	● OSSD/EMSS	● OSSD/EMSS
IN 2	Input Type	● GuardLink	● OSSD/EMSS	● GuardLink	● OSSD/EMSS
OUTX	Output Type	● OSSD	● OSSD	● OSSD	● OSSD
IN X	Input Mode	● OSSD Enabled	● OSSD Enabled	● OSSD Enabled	● OSSD Enabled
Reset	Reset Type	● Monitored Manual	● Monitored Manual	● Monitored Manual	● Monitored Manual
FB	Reset Assignment	● SOF	● SOF	● SOF	● SOF

Configuration 12

In Configuration 12, both safety inputs, Input 1 and Input 2, are in use. They can either be configured for GuardLink or OSSD with autodetect of EMSS devices. Input devices are not shown in the drawing.

The output type for OUT X (terminal X2) is configured for OSSD, and input IN X (terminal X1) is enabled. In this mode, IN X accepts a 24V DC input signal and output OUT X can be used as an immediate switching safety output to initiate a stop function of a drive. The 2-channel safety output 14/24 can drive the safety circuit for a Safe Torque Off with a delay time to perform a Stop Category 1 function.

The Reset mode is configured for manual monitored reset and is assigned to Input 1. After a demand of the safety function by Input 1, the outputs are enabled when all safety inputs are ACTIVE, the feedback signal is present, and a valid reset operation has been performed.

After a demand of the safety function by Input 2, the outputs are enabled when all safety inputs are ACTIVE and the feedback signal is present. A reset operation is not required.

Figure 58 - Two Safety Inputs, No SWS, Monitored Manual Reset Assigned to Input 1, Automatic Reset Assigned to Input 2 and IN X Schematic

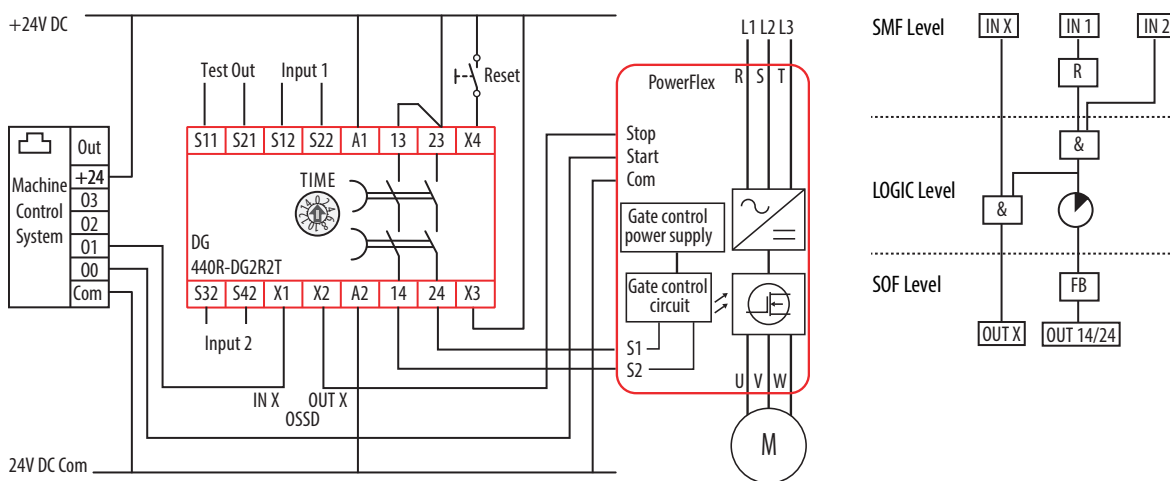

Table 34 - Configuration 12 — Hex (Dec)

Indicator	Function	Configuration ID: 0x37 (55)	Configuration ID: 0x33 (51)	Configuration ID: 0x35 (53)	Configuration ID: 0x31 (49)
OUT	Safety Functions	● IN1 and IN2	● IN1 and IN2	● IN1 and IN2	● IN1 and IN2
IN 1	Input Type	● GuardLink	● GuardLink	● OSSD/EMSS	● OSSD/EMSS
IN 2	Input Type	● GuardLink	● OSSD/EMSS	● GuardLink	● OSSD/EMSS
OUT X	Output Type	● OSSD	● OSSD	● OSSD	● OSSD
IN X	Input Mode	● OSSD Enabled	● OSSD Enabled	● OSSD Enabled	● OSSD Enabled
Reset	Reset Type	● Monitored Manual	● Monitored Manual	● Monitored Manual	● Monitored Manual
FB	Reset Assignment	● SMF IN1	● SMF IN1	● SMF IN1	● SMF IN1

Configuration 13

In Configuration 13, both safety inputs, Input 1 and Input 2, are in use. They can either be configured for GuardLink or OSSD with autodetect of EMSS devices. Input devices are not shown in the drawing.

The output type for OUT X (terminal X2) is configured for OSSD, and input IN X (terminal X1) is enabled. In this mode, IN X accepts a 24V DC input signal and output OUT X can be used as an immediate switching safety output to initiate a stop function of a drive. The 2-channel safety output 14/24 can drive the safety circuit for a Safe Torque Off with a delay time to perform a Stop Category 1 function.

The Reset mode is configured for automatic and assigned to the safety outputs. After a demand of the safety function by any input, the outputs are enabled when all safety inputs are ACTIVE and the feedback signal is present. A reset operation is not required.

Figure 59 - No SWS, Two Safety Inputs, Automatic Restart Assigned to Safety Outputs Schematic

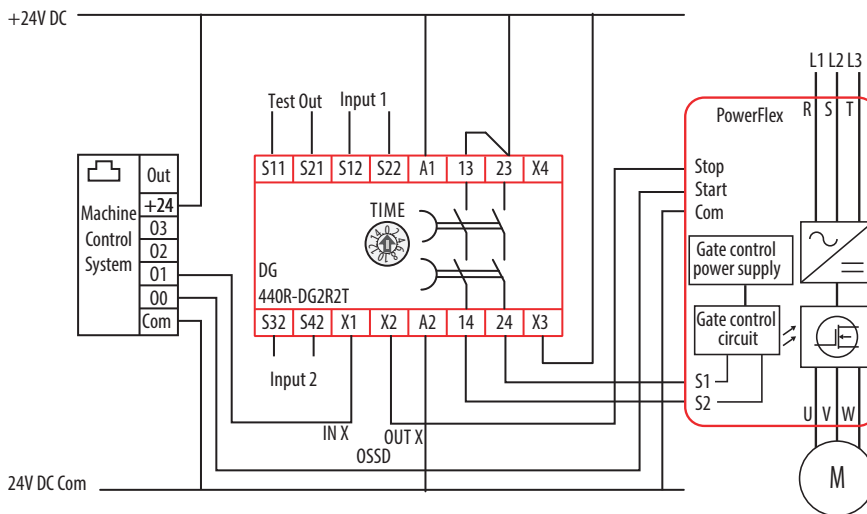

Logic

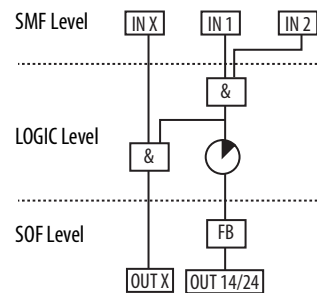

Table 35 - Configuration 13 — Hex (Dec)

Indicator	Function	Configuration ID: 0x17 (23)	Configuration ID: 0x13 (19)	Configuration ID: 0x15 (21)	Configuration ID: 0x11 (17)
OUT	Safety Functions	● IN1 and IN2	● IN1 and IN2	● IN1 and IN2	● IN1 and IN2
IN 1	Input Type	● GuardLink	● GuardLink	● OSSD/EMSS	● OSSD/EMSS
IN 2	Input Type	● GuardLink	● OSSD/EMSS	● GuardLink	● OSSD/EMSS
OUT X	Output Type	● OSSD	● OSSD	● OSSD	● OSSD
IN X	Input Mode	● OSSD Enabled	● OSSD Enabled	● OSSD Enabled	● OSSD Enabled
Reset	Reset Type	● Automatic	● Automatic	● Automatic	● Automatic
FB	Reset Assignment	● Not used	● Not used	● Not used	● Not used

Configuration 14

In Configuration 14, only safety Input 1 is in use. It can either be configured for GuardLink or OSSD with autodetect of EMSS devices. Input devices are not shown in the drawing.

The output type for OUT X (terminal X2) is configured for OSSD, and input IN X (terminal X1) is enabled. In this mode, IN X accepts a 24V DC input signal and output OUT X can be used as an immediate switching safety output to initiate a stop function of a drive. The 2-channel safety output 14/24 can drive the safety circuit for a Safe Torque Off with a delay time to perform a Stop Category 1 function.

The Reset mode is configured for manual monitored reset and is assigned to the safety outputs. The outputs are enabled when all inputs of the safety function are ACTIVE, the feedback signal is present, and a valid reset operation has been performed.

Figure 60 - No SWS, One Safety Input, Monitored Manual Reset Assigned to Safety Outputs Schematic

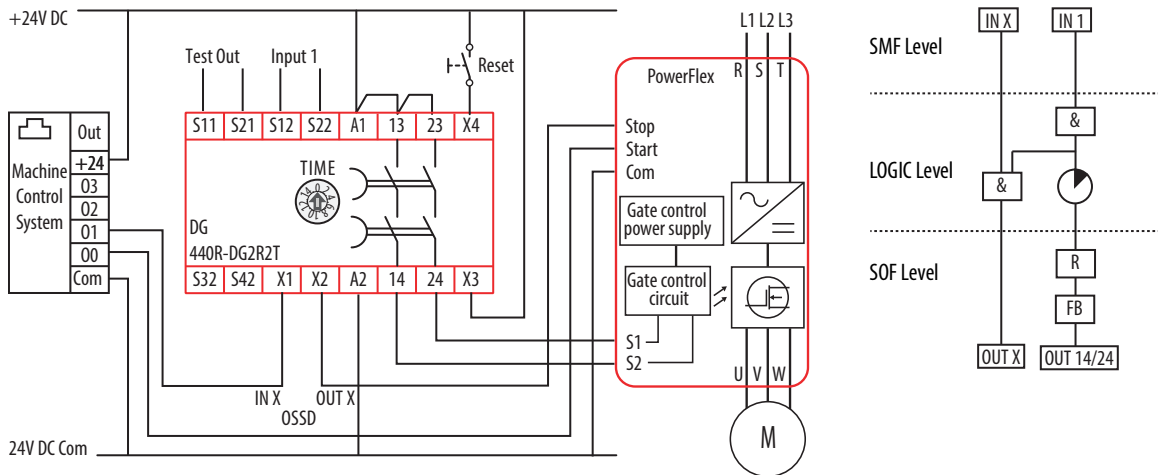

Table 36 - Configuration 14 — Hex (Dec)

Indicator	Function	Configuration ID: 0x72 (114)		Configuration ID: 0x70 (112)	
OUT	Safety Functions	●	IN1	●	IN1
IN 1	Input Type	●	GuardLink	●	OSSD/EMSS
IN 2	Input Type	●	Not used	●	Not used
OUT X	Output Type	●	OSSD	●	OSSD
IN X	Input Mode	●	OSSD Enabled	●	OSSD Enabled
Reset	Reset Type	●	Monitored Manual	●	Monitored Manual
FB	Reset Assignment	●	SOF	●	SOF

Configuration 15

In Configuration 15, only safety Input 1 is in use. It can either be configured for GuardLink or OSSD with autodetect of EMSS devices. Input devices are not shown in the drawing.

The output type for OUT X (terminal X2) is configured for OSSD, and input IN X (terminal X1) is enabled. In this mode, IN X accepts a 24V DC input signal and output OUT X can be used as an immediate switching safety output to initiate a stop function of a drive. The 2-channel safety output 14/24 can drive the safety circuit for a Safe Torque Off with a delay time to perform a Stop Category 1 function.

The Reset mode is configured for automatic and assigned to the safety outputs. After a demand of the safety function by any input, the outputs are enabled when the Input 1 safety input is ACTIVE and the feedback signal is present. A reset operation is not required.

Figure 61 - No SWS, One Safety Function, Automatic Reset Assigned to Safety Outputs Schematic

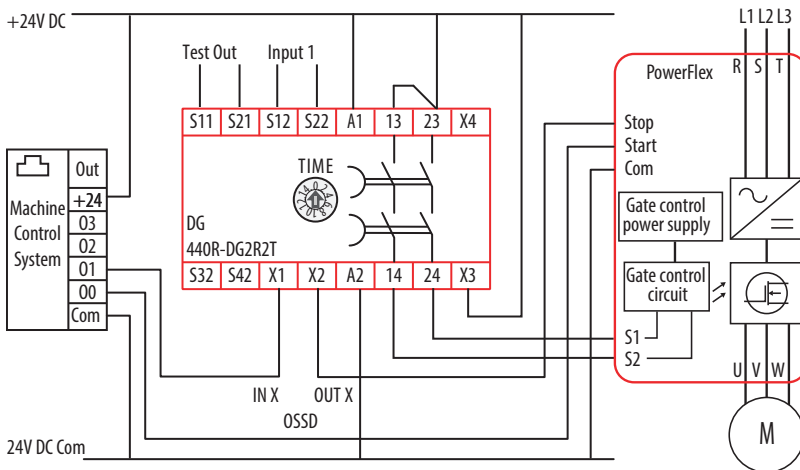

Logic

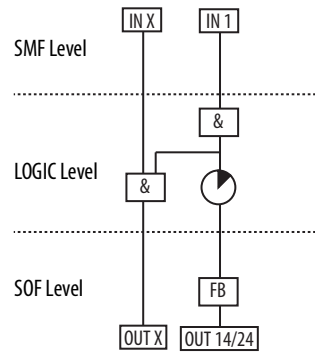

Table 37 - Configuration 15 — Hex (Dec)

Indicator	Function	Configuration ID: 0x12 (18)	Configuration ID: 0x10 (16)
OUT	Safety Functions	● IN1	● IN1
IN 1	Input Type	● GuardLink	● OSSD/EMSS
IN 2	Input Type	● Not used	● Not used
OUT X	Output Type	● OSSD	● OSSD
IN X	Input Mode	● OSSD Enabled	● OSSD Enabled
Reset	Reset Type	● Automatic	● Automatic
FB	Reset Assignment	● Not used	● Not used

Configuration 16

In Configuration 16, both safety inputs, Input 1 and Input 2, are in use. They can either be configured for GuardLink or OSSD with autodetect of EMSS devices. Input devices are not shown in the drawing.

The input IN X (terminal X1) is disabled. The output type for OUT X (terminal X2) is configured for OSSD and can be used as a status output or to drive another control device.

The reset mode is configured for manual monitored reset and is assigned to the safety outputs. The outputs are enabled when all safety inputs are ACTIVE, the feedback signal is present, and a valid reset operation has been performed.

Figure 62 - No SWS, Two Safety Inputs, Manual Monitored Reset Assigned to Safety Outputs Schematic

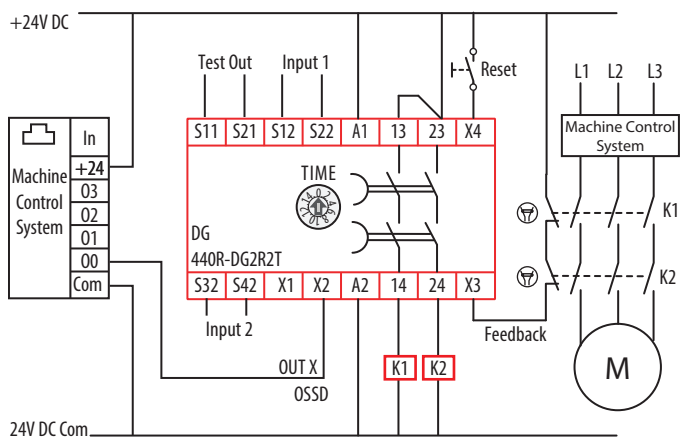

Logic

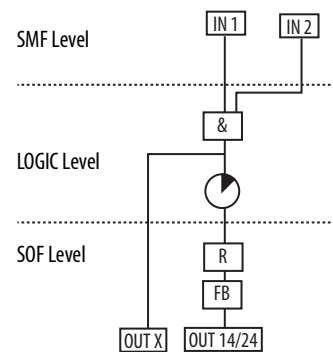

Table 38 - Configuration 16 — Hex (Dec)

Indicator	Function	Configuration ID: 0x67 (103)	Configuration ID: 0x63 (99)	Configuration ID: 0x65 (101)	Configuration ID: 0x61 (97)
OUT	Safety Functions	● IN1 and IN2	● IN1 and IN2	● IN1 and IN2	● IN1 and IN2
IN 1	Input Type	● GuardLink	● GuardLink	● OSSD/EMSS	● OSSD/EMSS
IN 2	Input Type	● GuardLink	● OSSD/EMSS	● GuardLink	● OSSD/EMSS
OUT X	Output Type	● OSSD	● OSSD	● OSSD	● OSSD
IN X	Input Mode	● OSSD Disabled	● OSSD Disabled	● OSSD Disabled	● OSSD Disabled
Reset	Reset Type	● Monitored Manual	● Monitored Manua	● Monitored Manual	● Monitored Manual
FB	Reset Assignment	● SOF	● SOF	● SOF	● SOF

Configuration 17

In Configuration 17, both safety inputs, Input 1 and Input 2, are in use. They can either be configured for GuardLink or OSSD with autodetect of EMSS devices. Input devices are not shown in the drawing.

The input IN X (terminal X1) is disabled. The output type for OUT X (terminal X2) is configured for OSSD and can be used as a status output or to drive another control device.

The Reset mode is configured for manual monitored reset and is assigned to Input 1. After a demand of the safety function by Input 1, the outputs are enabled when all safety inputs are ACTIVE, the feedback signal is present, and a valid reset operation has been performed.

After a demand of the safety function by Input 2, the outputs are enabled when all safety inputs are ACTIVE and the feedback signal is present. A reset operation is not required.

Figure 63 - No SWS, Two Safety Inputs, Monitored Manual Reset Assigned to Input 1, Automatic Reset Assigned to Input 2
Schematic

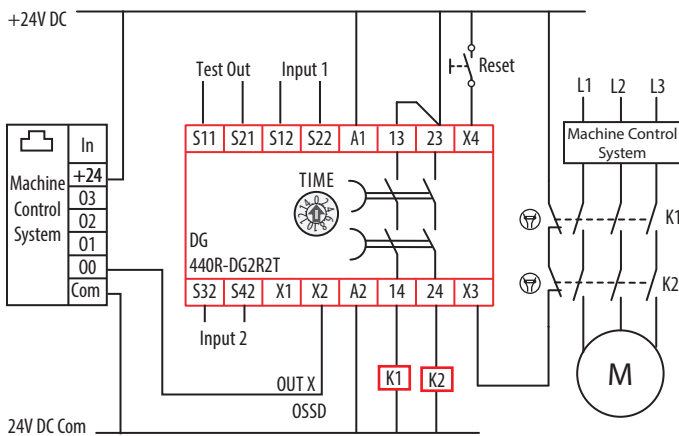

Logic

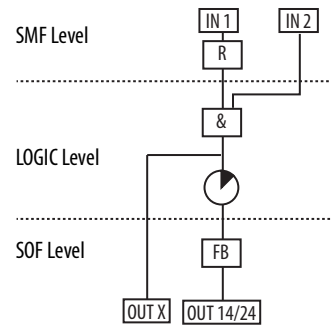

Table 39 - Configuration 17 — Hex (Dec)

Indicator	Function	Configuration ID: 0x27 (39)	Configuration ID: 0x23 (35)	Configuration ID: 0x25 (37)	Configuration ID: 0x21 (33)
OUT	Safety Functions	● IN1 and IN2	● IN1 and IN2	● IN1 and IN2	● IN1 and IN2
IN 1	Input Type	● GuardLink	● GuardLink	● OSSD/EMSS	● OSSD/EMSS
IN 2	Input Type	● GuardLink	● OSSD/EMSS	● GuardLink	● OSSD/EMSS
OUT X	Output Type	● OSSD	● OSSD	● OSSD	● OSSD
IN X	Input Mode	● OSSD Disabled	● OSSD Disabled	● OSSD Disabled	● OSSD Disabled
Reset	Reset Type	● Monitored Manual	● Monitored Manua	● Monitored Manual	● Monitored Manual
FB	Reset Assignment	● SMF IN1	● SMF IN1	● SMF IN1	● SMF IN1

Configuration 18

In Configuration 18, both safety inputs, Input 1 and Input 2, are in use. They can either be configured for GuardLink or OSSD with autodetect of EMSS devices. Input devices are not shown in the drawing.

The input IN X (terminal X1) is disabled. The output type for OUT X (terminal X2) is configured for OSSD and can be used as a status output or to drive another control device.

The reset mode is configured for automatic and assigned to the safety outputs. After a demand of the safety function by any input, the outputs are enabled when all safety inputs are ACTIVE and the feedback signal is present. A reset operation is not required.

Figure 64 - No SWS, Two Safety Inputs, Automatic Reset Assigned to Safety Outputs

Schematic

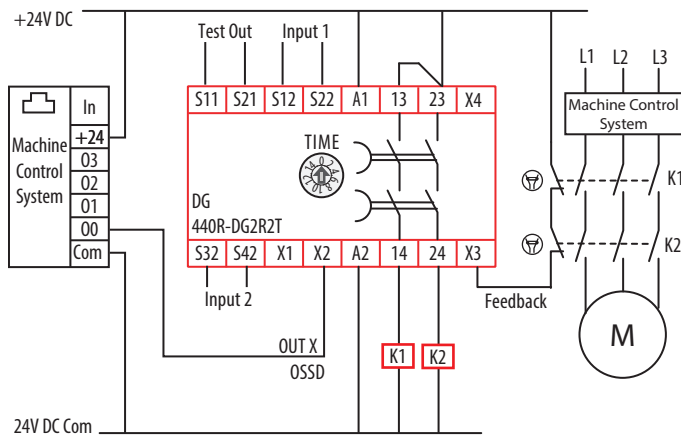

Logic

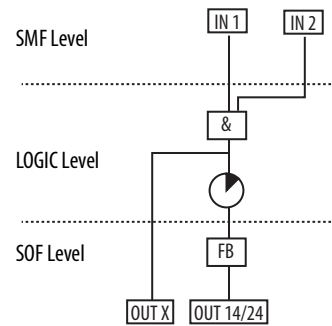

Table 40 - Configuration 18 — Hex (Dec)

Indicator	Function	Configuration ID: 0x07 (3)	Configuration ID: 0x03 (7)	Configuration ID: 0x05 (5)	Configuration ID: 0x01 (1)
OUT	Safety Functions	● IN1 and IN2	● IN1 and IN2	● IN1 and IN2	● IN1 and IN2
IN 1	Input Type	● GuardLink	● GuardLink	● OSSD/EMSS	● OSSD/EMSS
IN 2	Input Type	● GuardLink	● OSSD/EMSS	● GuardLink	● OSSD/EMSS
OUT X	Output Type	● OSSD	● OSSD	● OSSD	● OSSD
IN X	Input Mode	● OSSD Disabled	● OSSD Disabled	● OSSD Disabled	● OSSD Disabled
Reset	Reset Type	● Automatic	● Automatic	● Automatic	● Automatic
FB	Reset Assignment	● Not used	● Not used	● Not used	● Not used

Configuration 19

In Configuration 19, only safety Input 1 is in use. It can either be configured for GuardLink or OSSD with autodetect of EMSS devices. Input devices are not shown in the drawing.

The input IN X (terminal X1) is disabled. The output type for OUT X (terminal X2) is configured for OSSD and can be used as a status output or to drive another control device.

The reset mode is configured for manual monitored reset and is assigned to the safety outputs. The outputs are enabled when all inputs of the safety function are ACTIVE, the feedback signal is present, and a valid reset operation has been performed.

Figure 65 - First SWS Device, One Safety Input, Monitored Manual Reset Assigned to Safety Outputs

Schematic

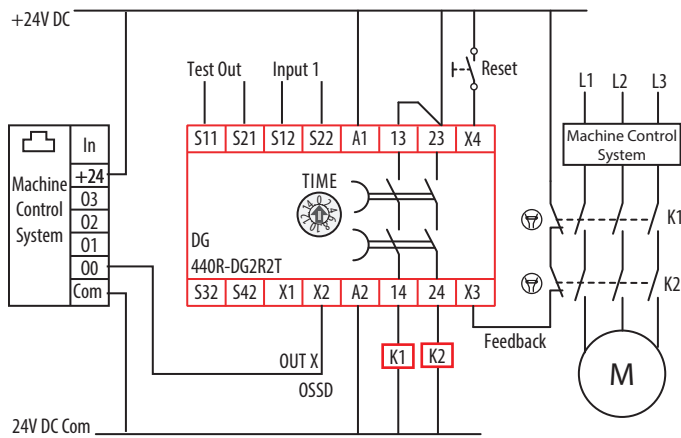

Logic

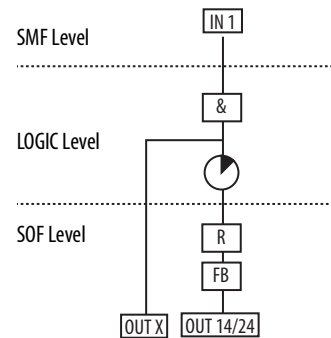

Table 41 - Configuration 19 — Hex (Dec)

Indicator	Function	Configuration ID: 0x62 (98)		Configuration ID: 0x60 (96)	
OUT	Safety Functions	●	IN1	●	IN1
IN 1	Input Type	●	GuardLink	●	OSSD/EMSS
IN 2	Input Type	●	Not used	●	Not used
OUT X	Output Type	●	OSSD	●	OSSD
IN X	Input Mode	●	OSSD Disabled	●	OSSD Disabled
Reset	Reset Type	●	Monitored Manual	●	Monitored Manual
FB	Reset Assignment	●	SOF	●	SOF

Configuration 20

In Configuration 20, only safety Input 1 is in use. It can either be configured for GuardLink or OSSD with autodetect of EMSS devices. Input devices are not shown in the drawing.

The input IN X (terminal X1) is disabled. The output type for OUT X (terminal X2) is configured for OSSD and can be used as a status output or to drive another control device.

The reset mode is configured for automatic and assigned to the safety outputs. After a demand of the safety function by any input, the outputs are enabled when all safety inputs are ACTIVE and the feedback signal is present. A reset operation is not required.

Figure 66 - No SWS, One Safety Input, Automatic Reset Assigned to Safety Outputs Schematic

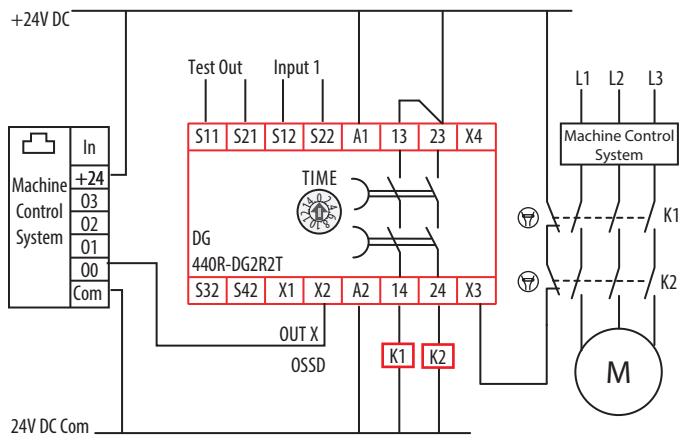

Logic

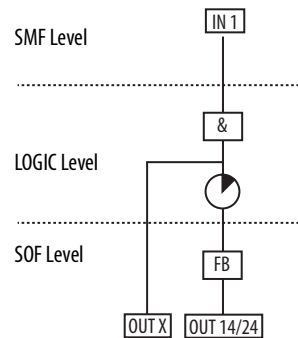

Table 42 - Configuration 20 — Hex (Dec)

Indicator	Function	Configuration ID: 0x02 (2)	Configuration ID: 0x00 (0)
OUT	Safety Functions	● IN1	● IN1
IN 1	Input Type	● GuardLink	● OSSD/EMSS
IN 2	Input Type	● Not used	● Not used
OUT X	Output Type	● OSSD	● OSSD
IN X	Input Mode	● OSSD Disabled	● OSSD Disabled
Reset	Reset Type	● Automatic	● Automatic
FB	Reset Assignment	● Not used	● Not used

Notes:

Regulatory Approvals

Agency Certifications

- UL Listed Industrial Control Equipment, certified for US and Canada.
- CE Marked for all applicable directives
- RCM marked for all applicable acts
- CCC Mark
- S-Mark
- KC marked for Korea

Waste Electrical and Electronic Equipment (WEEE)



At the end of its life, this equipment should be collected separately from any unsorted municipal waste.

Compliance to European Union Directives

This product has the CE Marking and is approved for installation within the European Union and EEA regions. It has been designed and tested to meet the following directives.

- Electromagnetic compatibility EMC Directive 2014/30/EU
- Low Voltage Directive 2014/35/EU
- Machinery Directive 2006/42/EC

Machine Safety Directive

This product is designed and tested to meet the European Council Directive 2006/42/EC on machinery and the following standards.

- IEC/EN 61508 - Functional safety of electrical/electronic/programmable electronic safety-related systems
- IEC/EN 62061 - Safety of machinery - Functional safety of safety-related electrical, electronic, and programmable electronic control systems
- EN ISO 13849-1 - Safety of machinery — Safety-related parts of control systems — Part 1: General principles for design

This product is intended for use in an industrial environment.

DG Safety Relay Ratings

SIL Rating

The DG safety relay meets the requirements of SIL in accordance with IEC/EN 61508 and SIL CL 3 in accordance with IEC/EN 62061.

Table 43 - SIL Ratings

Attribute	440R-DG2R2T
Safety integrity level	3
Safety integrity level claim limit [SILCL]	3
PFH _d [1/h]	1.92 x 10 ⁻⁸
Mode of operation	High-demand mode
Safety-related subsystems	Type B (use of programmable / complex components)
Hardware fault tolerance	HFT = 1 (dual channel system) HFT = 0 (single channel system)
Proof test interval, max [a]	20
Safe failure fraction [%]	98.9
Diagnostic coverage [%]	97.12

Performance Level/Category

The Performance Level of the safety function is dependent on the structure of all devices that comprise the safety function.

The DG safety relay is capable of being used in safety systems meeting up to Category 4 and Performance Level PLe in accordance with ISO 13849-1.

Table 44 - DG Performance Level Ratings

Attribute	440R-DG2R2T
Category	Up to 4
Performance Level	Up to e
MTTF _d [a]	92.2
DC _{avg} [%]	97.31
SFF [%]	99.06
CCF	80

Tap Ratings

SIL Rating

The tap modules can be used in systems that require up to SIL 3 in accordance with IEC/EN 61508 and SIL CL 3 in accordance with EN 62061. A comprehensive analysis of the components that comprise the safety system function determines the actual performance rating.

Table 45 - Tap SIL Ratings

Attribute	440S-SF8D, 440S-SF5D, 440S-MF5D, 440S-MF8D
Safety integrity level	3
Safety integrity level claim limit [SILCL]	3
PFH _d [1/h]	2.65×10^{-10}
Mode of operation	High-demand mode
Proof test interval, max [a]	20
Safe failure fraction [%]	98.68

Table 46 - Tap Lock Command SIL Ratings

Attribute	440S-SF8D, 440S-SF5D, 440S-MF5D, 440S-MF8D
Safety integrity level	2
Safety integrity level claim limit [SILCL]	2
PFH _d [1/h]	1.5×10^{-9}
Mode of operation	High-demand mode
Proof test interval, max [a]	20
Safe failure fraction [%]	98.16

Performance Level/Category

The Performance Level of the safety function is dependent on the structure of all devices that comprise the safety function. The GuardLink taps are capable of being used in safety systems meeting up to Category 4 and Performance Level PLe in accordance with ISO 13849-1.

Table 47 - Tap Performance Level Ratings

Attribute	Taps
Category	Up to 4
Performance Level	Up to e
MTTFd [a]	1943.07
DCavg [%]	97.65
SFF [%]	99.00
CCF	80

Table 48 - Tap Lock Command Performance Level Ratings

Attribute	Taps
Category	Up to 2
Performance Level	Up to d
MTTFd [a]	2159.99
DCavg [%]	92.78
SFF [%]	98.24
CCF	80

EMC Directive

This product is designed and tested to meet the European Council Directive 2014/30/EU on Electromagnetic Compatibility (EMC) and the following standards:

- EN 55011: Industrial, scientific, and medical equipment - Radio frequency disturbance characteristics - Limits and methods of measurement CISPR 11:2009 (Modified)
- EN 61000-6-2: Generic Standards - Immunity for Industrial Environments
- EN 61000-6-7: Electromagnetic compatibility (EMC) Generic standards. Immunity requirements for equipment that is intended to perform functions in a safety-related system (functional safety) in industrial locations.
- EN 61326-3-1: Electrical equipment for measurement, control, and laboratory use - EMC requirements - Part 3-1: Immunity requirements for safety-related systems and for equipment that is intended to perform safety-related functions (functional safety) - General industrial applications

This product is intended for use in an industrial environment.

Declaration of Conformity

For the latest Declaration of Conformity (DoC), see the following:

- Tap: https://literature.rockwellautomation.com/idc/groups/literature/documents/ct/440s-ct002_-en-e.pdf
- DG safety relay: https://literature.rockwellautomation.com/idc/groups/literature/documents/ct/440r-ct004_-en-e.pdf

Notes:

DG Safety Relay Indicator Fault Codes

Determine a Fault

The DG safety relay performs an extensive range of internal tests to verify the performance of the safety function. When the PWR/Fault indicator is flashing red at 1 Hz, the indicators on the front of the DG safety relay can provide information on the fault.

Use the following procedure to determine the fault.

1. Press the Config/Set button.
2. Read the flashing red indicators for the Faulted Module.
3. Press the Config/Set button again.
4. Read the flashing green indicators for the Fault number. If there are no flashing green indicators; the Fault ID value is 0.
5. Add the values as shown in the example in [Table 49 on page 102](#).
6. Use the total of the values to look up the Module and Fault IDs in [Table 50 on page 102](#).

Clear a Fault

Use the following recommended actions to clear a fault.

1. Where a terminal is specified, check the wiring and, if possible, measure the voltage to confirm the status at the specified terminal.
2. Where the Time Delay switch has been changed in Module 21, return the switch to its original position and cycle power.
3. Where the Time Delay switch has been changed in Module 22, simply return the switch to its original position.
4. Cycle power to the relay to clear the fault.
5. If the fault is not cleared, reconfigure the relay.
6. If the fault persists, replace the relay.

An example fault is shown in [Table 49 on page 102](#). This fault can easily be demonstrated by turning the Delay switch to a new position after the relay has been successfully configured. In this example, the rotary switch is not in position 3. Return the switch to position 3, and the fault is cleared.

Table 49 - Example Fault after Configuration











Indicator	Module		Fault ID	
	Color Red	Value	Color Green	Value
PWR/Fault		128		128
OUT		64		64
IN1		32		32
IN2		16		16
OUT X		8		8
IN X		4		4
Reset		2		2
FB		1		1
Total Value		22		3

Table 50 - Indicator Fault Codes

Module	Module Description	Fault ID	Fault Description
1...5	Internal Fault	All	Various faults
6	Configuration Procedure	1	Status host configuration is invalid
		2	Default case configuration procedure
		3	Load type one configuration failed
		4	Device not configured
		5	Load configuration table failed
		6	Existing configuration does not match EEPROM data
		7	Load existing configuration failed
		8	Save configuration PB And CRC In EEPROM failed
		9	CRC check of copied data failed
		10	CRC check of copied data failed, invalid amount of data
		11	Compare received data CRC with co-safety processor failed
7...14	Internal Fault	All	Various faults
15	Plausibility Tests	1	Terminal S11 should be HI
		2	Terminal S21 should be HI
		3	Terminal S12 should be HI
		4	Terminal S22 should be HI
		5	Terminal S32 should be HI
		6	Terminal S42 should be HI
		7	Terminal X1 should be HI
		8	Terminal X2 should be HI
		11	Terminal S11 should be LO
		12	Terminal S21 should be LO
		13	Terminal S12 should be LO

Table 50 - Indicator Fault Codes

Module	Module Description	Fault ID	Fault Description
15	Plausibility Tests	14	Terminal S22 should be LO
		15	Terminal S32 should be LO
		16	Terminal S42 should be LO
		17	Terminal X1 should be LO
		18	Terminal X2 should be LO
		21	Feedback internal relay coil should be HI
		22	Feedback internal relay coil should be LO
		23	Terminal X4 should be HI
		24	Terminal X4 should be LO
		31	MT should be HI
16	Internal Fault	ALL	Various faults
17	Read Inputs	1	Default Case
		2	Terminal S22. The CLU signal has an invalid pattern
		3	Terminal S42. The CLU signal has an invalid pattern
		4	Terminal X1 SWS signal has an invalid pattern
		5	Terminal X2 SWS signal has an invalid pattern
		6	Default Case Call of Input Interpretation
		7	Default Case Read Input Once
		8	Default Case Mon DC Once
18...19	Internal Fault	All	Various Faults
20	Start Up Tests	1	Internal main transistor is ON when it should be OFF
		2	Internal main transistor is OFF when it should be ON
		3	Internal main transistor is ON when it should be OFF
		4	Terminal S11stuck at HI
		5	Terminal S21stuck at HI
		6	Terminal S12stuck at HI
		7	Terminal S32stuck at HI
		11	Terminal S11 internal test switch N.C.
		12	Terminal S21 internal test switch N.C.
		13	Terminal S12 internal test switch N.C.
		14	Terminal S22 internal test switch N.C.
		15	Terminal S32 internal test switch N.C.
		16	Terminal S42 internal test switch N.C.
		17	Terminal X1 internal test switch N.C.
		18	Terminal X2 internal test switch N.C.
		21	Terminal S11 should be LO
		22	Terminal S21 should be LO
		23	Terminal S12 should be LO
		24	Terminal S22 should be LO
		25	Terminal S32 should be LO
26	Terminal S42 should be LO		
27	Terminal X1 should be LO		
28	Terminal X2 should be LO		
30	—		
31	Internal feedback relay is energized		
32			

Table 50 - Indicator Fault Codes

Module	Module Description	Fault ID	Fault Description
21	Invalid Rotary Position During Power-up	0	Saved position is 0
		1	Saved position is 1
		2	Saved position is 2
		3	Saved position is 3
		4	Saved position is 4
		5	Saved position is 5
		6	Saved position is 6
		7	Saved position is 7
		8	Saved position is 8
		9	Saved position is 9
		10	Saved position is 10
		11	Saved position is 11
		12	Saved position is 12
		13	Saved position is 13
		14	Saved position is 14
		15	Saved position is 15
		20	Default case
22	Invalid Rotary Position During Run	0	Saved position is 0
		1	Saved position is 1
		2	Saved position is 2
		3	Saved position is 3
		4	Saved position is 4
		5	Saved position is 5
		6	Saved position is 6
		7	Saved position is 7
		8	Saved position is 8
		9	Saved position is 9
		10	Saved position is 10
		11	Saved position is 11
		12	Saved position is 12
		13	Saved position is 13
		14	Saved position is 14
		15	Saved position is 15
		20	Rotary switch pin has short circuit
23...46	Internal Fault	All	Various faults

Numerics

- 13/14**
 - safety output 46
- 23/24**
 - safety output 46
- 440R-ENETR (Ethernet) interface**
 - arrangement 60

A

- agency certification** 95
- AOP**
 - verification 54
- arrangement**
 - 440R-ENETR (Ethernet) interface 60

B

- bus**
 - optical 59

C

- cabling**
 - tap 28
- calculation**
 - safety function 61
 - GuardLink system 61
 - SISTEMA 63
 - system current 24
- certification**
 - agency 95
- clear**
 - fault 101
- CLU signal** 8
- command**
 - fault reset 17
- communication**
 - opto-link 59
- compliance**
 - European Union directives 95
- config/set**
 - configuration mode 50
 - push button 49
 - run mode 49
- configuration** 49
 - example 71
 - mode
 - config/set 50
 - sel./save 50
 - steps 50
- conformity**
 - declaration of 99

connection

- power supply
 - DG safety relay 41
 - multiple 43
 - tap 42
- single wire safety 45
- SWS 45

consideration

- enclosure 35
- voltage drop 25

contact

- voltage-free 9

control, lock, and unlock signal 8

D

declaration of conformity 99

definition 8

delay setting 53

determine

- fault 101

DG safety relay

- enclosure consideration 35
- excessive heat 36
- output monitoring 13
- overview 13
- performance level/category 96
- power supply connection 41
- reset 14
- safety device input 13
- SIL rating 96
- single wire safety input 13
- status indicators 55
- terminal assignment 38
- terminal function 38
- terminal torque 37
- wire size 37

dimension

- mounting 31

DIN rail

- mounting/DIN rail
 - removal 32
- spacing 32

directive

- compliance to European Union 95
- machine safety 95

E**electrical and electronic equipment** 95**electrical mechanical safety switch** 8**EMC directive**

tap 98

EMSS 8

tap 18

EMSS SmartTap

pulse test 58

enclosure

consideration 35

DG safety relay 35

tap 35

European Union directives

compliance 95

example

configuration 71

fault 102

excessive heat

prevent 36

F**fault**

clear 101

determine 101

example 102

fault code

indicator 102

fault reset command 17**function**

pulse testing 57

safety 8

G**ground** 37**guard locking**

GuardLink system 18

GuardLink

connectionsinput wiring 43

fault reset command 17

guard locking 18

principle of operation 15

state 15

system

typical 12

what is 11

system design 23

transition (operational state - safe state) 17

transition (safe state - operational state) 17

H**heat**

prevent excessive 36

HI 8**I****indicator**

fault code 102

status 9, 55

DG safety relay 55

tap 56

input

pulse testing 57

single wire safety 13

SWS 13

input wiring

DG safety relay 43

GuardLink connections 43

OSSD output device 44

voltage-free contact 44

installation 31

tap 34

L**LO** 8**lock command**

timing diagram 19

M**machine safety directive** 95**mode**

configuration

config/set 50

sel./save 50

run

config/set 49

sel./save 50

monitoring

output 13

mounting

dimension 31

DIN rail 32

multiple

power supply connection 43

N**N.C.** 8**N.O.** 8**N/C** 8**normally closed** 8**normally open** 8

O

operation
GuardLink, principle 15

operational state
GuardLink 8

optical bus 59

opto-link
communication 59

OSSD 8
tap 18

OSSD output device
input wiring 44

output
monitoring 13

output signal
switching device 8

output wiring
safety 46

overview 11
DG safety relay 13
tap 12

P

performance level/category
DG safety relay 96
tap 98

pin assignment
tap 39

pin function
tap 39

power 37

power supply
connection
DG safety relay 41
multiple 43
tap 42

prevent
excessive heat 36

protection
surge 47

pulse test
EMSS SmartTap 58

pulse testing
function 57
input 57

push button
config/set 49
sel./save 50
verification 54

R

reaction time 8

recommendation
wiring 37

recovery time 8

regulatory approval 95

removal
DIN rail 32
terminal block 33

replacement
tap 29
terminal block 33

requirement
wiring 37

reset 14, 50

response time 8

run mode
config/set 49
sel./save 50

S

safe state
GuardLink 8

safety
device input 13
function 8
output
13/14 and 23/24 46
output wiring 46
signal, GuardLink 8
single wire 9, 45
connection 45

safety function
calculation 61
GuardLink system 61
SISTEMA 63

safety switch
electrical mechanical 8

sel./save
configuration mode 50
push button 50
run mode 50

setting
delay 53

signal
GuardLink safety 8

SIL rating
DG safety relay 96
tap 97

single wire safety 9, 45
connection 45
input 13

spacing
DIN rail 32

specifications 65 ... 69

- electrical
 - tap 68
- environmental
 - DG relay 65
 - tap 69
- general
 - DG relay 65
 - tap 68
- input device with voltage-free contacts
 - DG relay 66
- pulse test output
 - DG relay 66
- safety output
 - DG relay 67
- SWS
 - DG relay 67
 - tap 68

state

- GuardLink 15
- GuardLink operational 8
- GuardLink safe 8
- status indicator 9

status indicator 9

- state 9

status indicators 55

- DG safety relay 55
- tap 56

steps

- configuration 50

surge protection 47

surge suppressor

- recommendation 47

switching device

- output signal 8

SWS 9, 45

- connection 45
- input 13

system current

- calculation 24

system design

- GuardLink 23

T

tap 9

- cabling 28
- EMC directive 98
- EMSS 18
- enclosure consideration 35
- excessive heat 36
- installation 34
- OSSD 18
- overview 12
- performance level/category 98
- pin assignment 39
- pin function 39
- power supply connection 42
- replacement 29
- SIL rating 97
- specifications 68
- status indicators 56

terminal assignment

- DG safety relay 38

terminal block

- removal 33
- replacement 33

terminal function

- DG safety relay 38

terminal torque

- DG safety relay 37

terminator

time

- reaction 8
- recovery 8
- response 8

timing diagram

- lock command 19

transition

- GuardLink (operational state - safe state) 17
- GuardLink (safe state - operational state) 17

V

verification

- AOP 54
- push button 54

voltage drop

- consideration 25

voltage-free contact

- input wiring 44

W

waste

waste electrical and electronic equipment

WEEE

wire

wire size

- DG safety relay 37

wiring

- recommendation 37
- requirement 37
- safety output 46

Rockwell Automation Support

Use the following resources to access support information.

Technical Support Center	Knowledgebase Articles, How-to Videos, FAQs, Chat, User Forums, and Product Notification Updates.	www.rockwellautomation.com/knowledgebase
Local Technical Support Phone Numbers	Locate the phone number for your country.	www.rockwellautomation.com/global/support/get-support-now.page
Direct Dial Codes	Find the Direct Dial Code for your product. Use the code to route your call directly to a technical support engineer.	www.rockwellautomation.com/global/support/direct-dial.page
Literature Library	Installation Instructions, Manuals, Brochures, and Technical Data.	www.rockwellautomation.com/literature
Product Compatibility and Download Center (PCDC)	Get help determining how products interact, check features and capabilities, and find associated firmware.	www.rockwellautomation.com/global/support/pcdc.page

Documentation Feedback

Your comments will help us serve your documentation needs better. If you have any suggestions on how to improve this document, complete the How Are We Doing? form at http://literature.rockwellautomation.com/idc/groups/literature/documents/du/ra-du002_-en-e.pdf.

Rockwell Automation maintains current product environmental information on its website at <http://www.rockwellautomation.com/rockwellautomation/about-us/sustainability-ethics/product-environmental-compliance.page>.

Allen-Bradley, GuardLink, GuardMaster, Rockwell Automation, Rockwell Software, SensaGuard, and Studio 5000 are trademarks of Rockwell Automation, Inc.

Trademarks not belonging to Rockwell Automation are property of their respective companies.

www.rockwellautomation.com

Power, Control and Information Solutions Headquarters

Americas: Rockwell Automation, 1201 South Second Street, Milwaukee, WI 53204-2496 USA, Tel: (1) 414.382.2000, Fax: (1) 414.382.4444

Europe/Middle East/Africa: Rockwell Automation NV, Pegasus Park, De Kleetlaan 12a, 1831 Diegem, Belgium, Tel: (32) 2 663 0600, Fax: (32) 2 663 0640

Asia Pacific: Rockwell Automation, Level 14, Core F, Cyberport 3, 100 Cyberport Road, Hong Kong, Tel: (852) 2887 4788, Fax: (852) 2508 1846

Publication 440R-UM015D-EN-P - March 2019

Supersedes Publication 440R-UM015C-EN-P - April 2018

Copyright © 2019 Rockwell Automation, Inc. All rights reserved. Printed in the U.S.A.