

MMBT4403-HF (PNP)

RoHS Device

Halogen Free

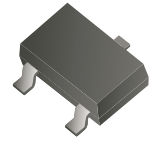

Features

- Epoxy meets UL-94 V-0 flammability rating.
- Moisture sensitivity Level 1.

Mechanical data

- Case: SOT-23, molded plastic.
- Terminals: Tin plated leads, solderable per J-STD-002 and JESD22-B102.

Circuit Diagram

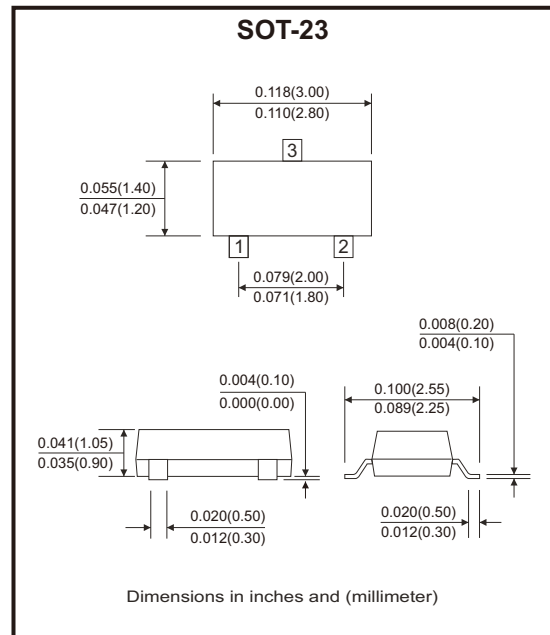
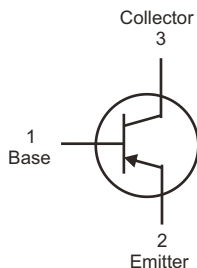

Maximum Ratings (at $T_A=25^\circ\text{C}$ unless otherwise noted)

Parameter	Symbol	Value	Unit
Collector-base voltage	V_{CB0}	-40	V
Collector-emitter voltage	V_{CEO}	-40	V
Emitter-base voltage	V_{EBO}	-5	V
Collector current	I_C	-0.6	A
Collector power dissipation	P_C	300	mW
Operation junction temperature	T_J	150	$^\circ\text{C}$
Storage temperature range	T_{STG}	-55 to +150	$^\circ\text{C}$
Thermal resistance from junction to ambient	$R_{\theta JA}$	417	$^\circ\text{C/W}$

Electrical Characteristics (at $T_A=25^\circ\text{C}$ unless otherwise noted)

Parameter	Symbol	Conditions	Min.	Typ.	Max.	Unit
Collector-base breakdown voltage	V_{CB0}	$I_C = -100\mu\text{A}, I_E = 0$	-40			V
Collector-emitter breakdown voltage	V_{CEO}	$I_C = -1\text{mA}, I_B = 0$	-40			V
Emitter-base breakdown voltage	V_{EB0}	$I_E = -100\mu\text{A}, I_C = 0$	-5			V
Collector-base cut-off current	I_{CBO}	$V_{CB} = -35\text{V}, I_E = 0$			-0.1	μA
Collector-emitter cut-off current	I_{CEO}	$V_{CE} = -35\text{V}, I_B = 0$			-0.1	μA
Emitter-base cut-off current	I_{EBO}	$V_{EB} = -4\text{V}, I_C = 0\text{V}$			-0.1	μA
DC current gain	h_{FE}	$V_{CE} = -2\text{V}, I_C = -150\text{mA}$	100		300	
Collector-emitter saturation voltage	$V_{CE(sat)}$	$I_C = -150\text{mA}, I_B = -15\text{mA}$			-0.40	V
Base-emitter saturation voltage	$V_{BE(sat)}$	$I_C = -150\text{mA}, I_B = -15\text{mA}$			-0.95	V
Transition frequency	f_T	$V_{CE} = -10\text{V}, I_C = -20\text{mA}, f = 100\text{MHz}$	200			MHz
Delay time	t_d	$V_{CC} = -3\text{V}, V_{BE} = -2\text{V},$			15	ns
Rise time	t_r	$I_C = -150\text{mA}, I_{B1} = -15\text{mA}$			20	ns
Storage time	t_s	$V_{CC} = -3\text{V}, I_C = -150\text{mA},$			225	ns
Fall time	t_f	$I_{B1} = I_{B2} = -15\text{mA}$			30	ns

Rating and Characteristic Curves (MMBT4403-HF)

Fig.1 - Static Characteristic

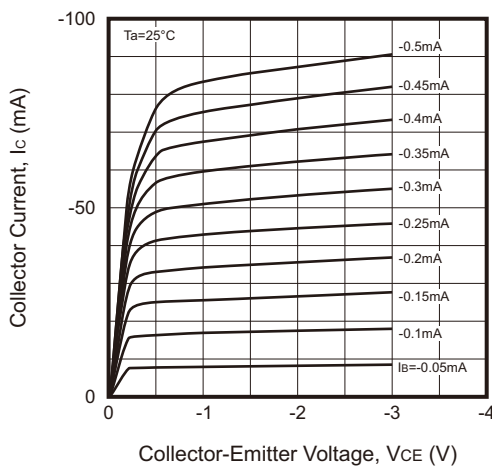
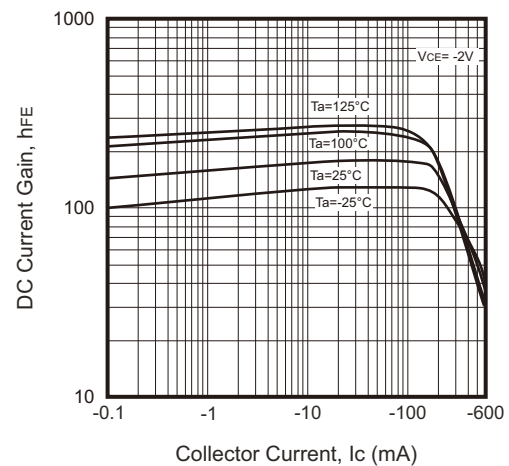

Fig.2 - DC Current Gain



Rating and Characteristic Curves (MMBT4403-HF)

Fig.3 - Collector-Emitter Saturation Voltage

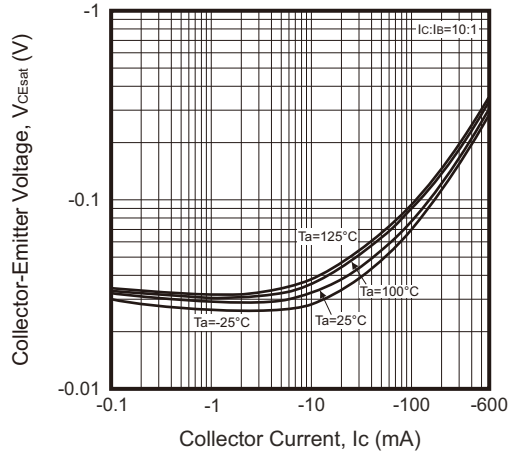

Fig.4 - Base-Emitter Saturation Voltage

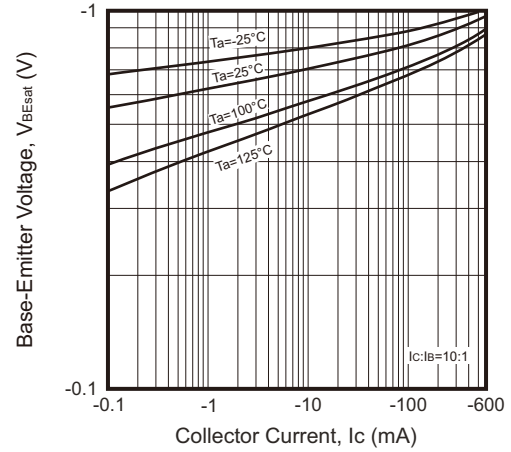

Fig.5 - Base-Emitter on Voltage

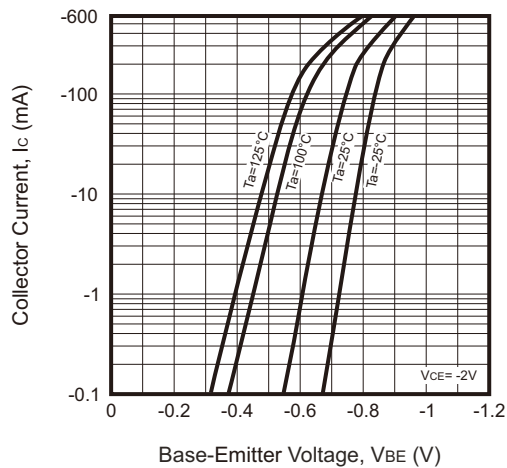

Fig.6 - $C_{ob}/C_{ib} - V_{CB}/V_{EB}$

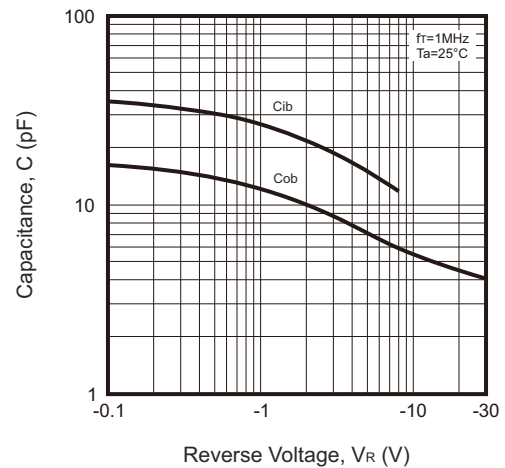
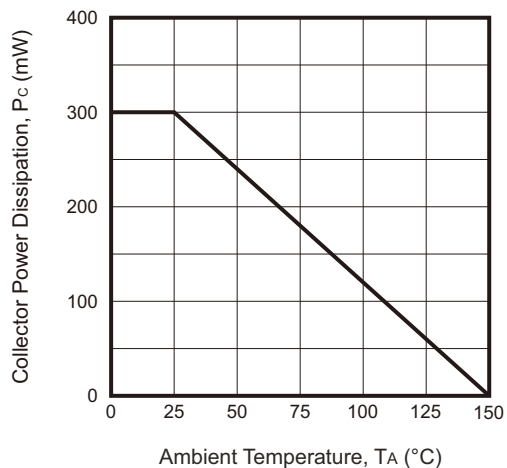

Fig.7 - Collector Power Derating Curve



Company reserves the right to improve product design, functions and reliability without notice.

REV:B

Reel Taping Specification

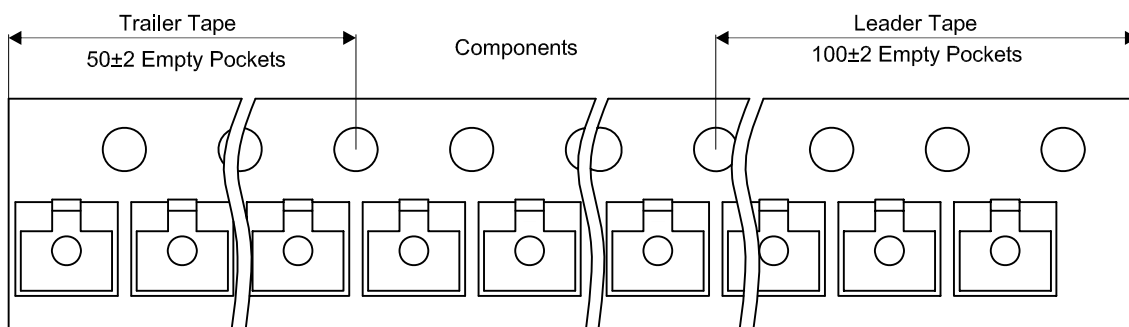
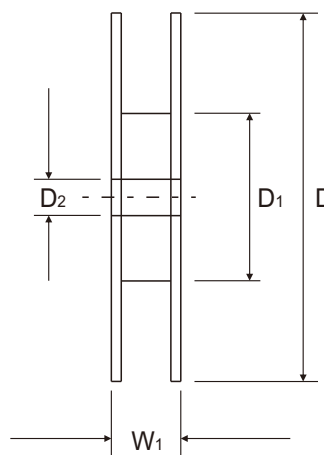
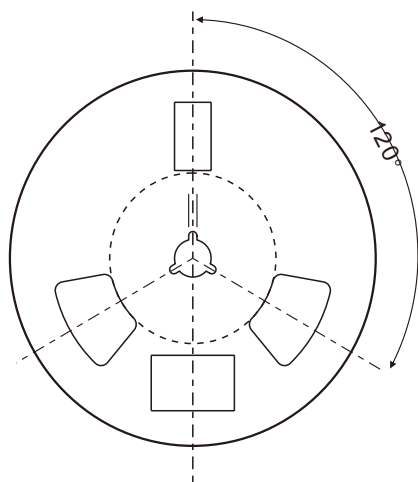
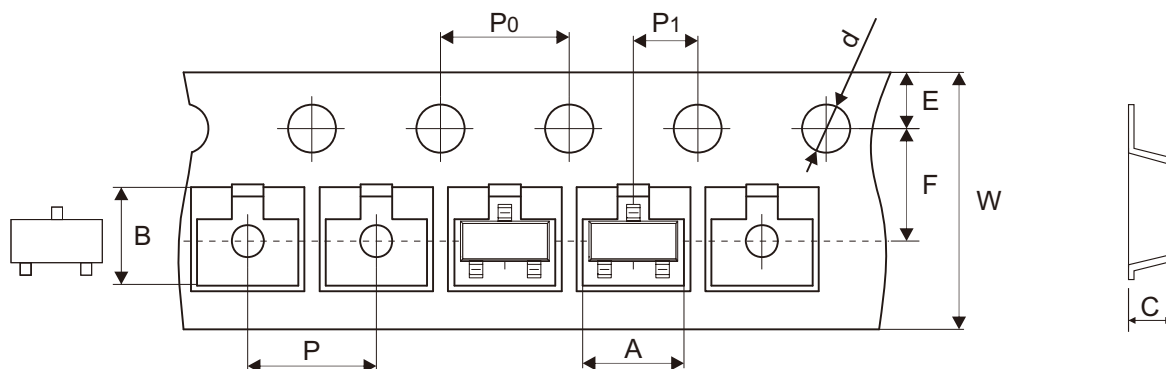

SOT-23	SYMBOL	A	B	C	d	D	D1	D2
	(mm)	3.15 ± 0.10	2.77 ± 0.10	1.22 ± 0.10	1.50 + 0.10 - 0.00	178.00 ± 1.00	54.60 ± 1.00	13.30 ± 1.00
	(inch)	0.124 ± 0.004	0.109 ± 0.004	0.048 ± 0.004	0.059 + 0.004 - 0.000	7.008 ± 0.039	2.150 ± 0.039	0.524 ± 0.039

SOT-23	SYMBOL	E	F	P	P0	P1	W	W1
	(mm)	1.75 ± 0.10	3.50 ± 0.05	4.00 ± 0.10	4.00 ± 0.10	2.00 ± 0.05	8.00 + 0.30 - 0.10	11.10 ± 0.20
	(inch)	0.069 ± 0.004	0.138 ± 0.002	0.157 ± 0.004	0.157 ± 0.004	0.079 ± 0.002	0.315 + 0.012 - 0.004	0.437 ± 0.008

Company reserves the right to improve product design, functions and reliability without notice.

REV:B

Marking Code

Part Number	Marking Code
MMBT4403-HF	2T

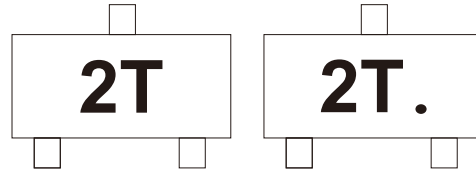

Solid dot = Control code

Suggested P.C.B. PAD Layout

SIZE	SOT-23	
	(mm)	(inch)
A	0.90	0.035
B	0.80	0.031
C	0.95	0.037
D	2.00	0.079
E	2.90	0.114

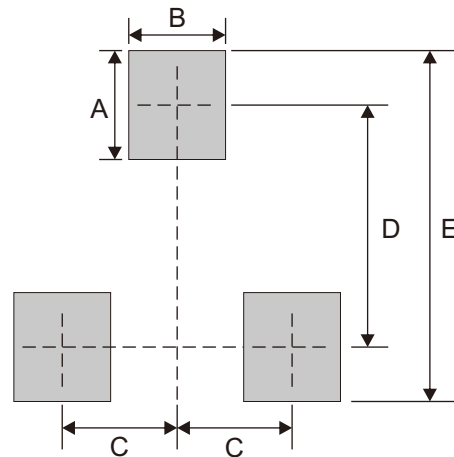

Note: 1. The pad layout is for reference purposes only.

Standard Packaging

Case Type	REEL PACK	
	REEL (pcs)	Reel Size (inch)
SOT-23	3,000	7