

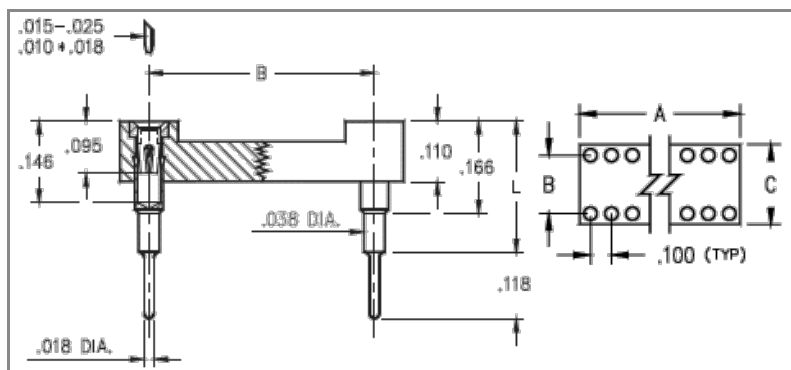

PRODUCT NUMBER: 116-93-210-41-007000

www.mill-max.com
DATA SHEET



116-93-210-41-007000- SPECIFICATIONS

General Info	
Description¹:	Elevated Profile
Type:	DIP
Category:	Dual In Line Socket
Mounting Style:	Through Hole Solder Mount
# Pins:	10
Packaging:	Packaged in Tubes
Qty Tube:	40
RoHS:	No
Product Lifecycle:	Active

Materials	
Shell Plating:	200 μ" Tin/Lead(93/7) over 100 μ" Nickel
Inner Plating:	30 μ" Gold over 50 μ" Nickel
Loose Pin/Receptacle Used:	0153 (Brass Alloy)
Insulator Material:	PCT

Technical Specs	
Pitch:	.100" (2,540mm)
A Dim:	.500" (12,700mm)
B Dim:	.200" (5,080mm)
C Dim:	.300" (7,620mm)
L Dim:	.402" (10,211mm)

NOTES:

1. Standard Tolerances:

Assembly tolerance: +/- .010" (.25mm)

Insulator length: +/- .005 (.13mm)

Insulator width: +/- .005 (.13mm)

Insulator height: +/- .005 (.13mm)

Pin Length: +/- .005 (.13mm)

Pin Diameter: +/- .002 (.051mm)

Pin Angle: +/- 2°

Co-planarity of SMT connectors: .005" (.13mm) up to 1" (25.4mm) in connector length

Insulator Flatness: .005" (.13mm) up to 1" (25.4mm) in connector length

CONTACT:

#30 CONTACT FOR .015"-.025" DIAMETER PINS ($\delta = .005$) 4-FINGER (BeCu), GROUP C

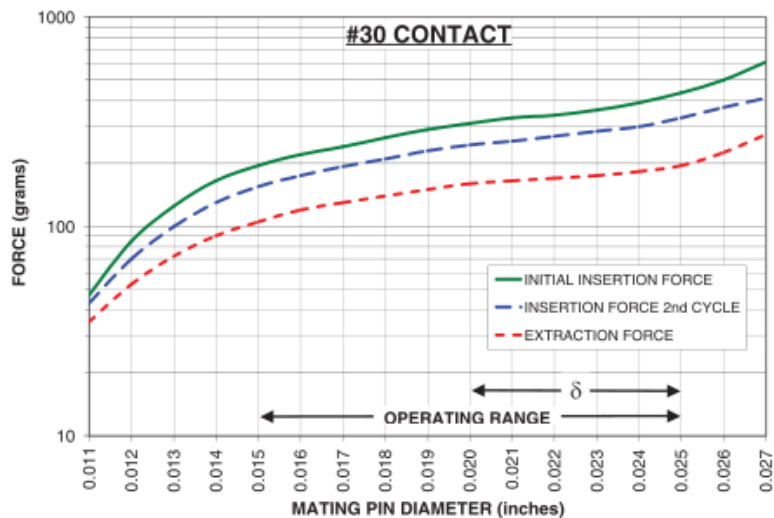
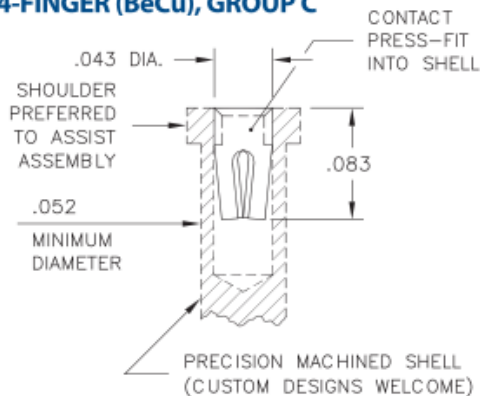

The insertion / extraction force characteristics above were derived using a 30 microinch gold-plated contact and polished steel gauge pins having a bullet-shaped tip. The curves represent typical average values; they are best used to compare the differences between similar size contacts and to guide you in selecting one that is suitable for your application. Your results may vary, so for your specification, we encourage you to obtain complimentary samples for your evaluation.

Material	Beryllium Copper	Current Rating (amps)	3.00
Fingers	4	Compliance	.005" (0,127mm)
Length	.080" (2,032mm)		
Group Code	C		

ADDITIONAL NOTES AND SPECIFICATIONS

In the interest of improved design, quality and performance, Mill-Max reserves the right to make changes in its specifications without prior notice. Specifications and tolerances are provided wherever possible. The tolerance on dimensions of critical to function features is typically held tighter than the stated standard tolerances, such as press-fits, holes and lengths affecting the coplanarity of SMT products. Due to the wide variety of interconnects Mill-Max offers, the specific tolerances vary from product to product. If you need information regarding the tolerance of a particular part, please contact Technical Services.