

NCP81278

Compact 2-Phase Synchronous Buck Controller with Integrated Gate Drivers and PWM VID Interface

The NCP81278, a general-purpose two-phase synchronous buck controller, integrates gate drivers and PWM VID interface in a QFN-20 package and provides a compact-footprint power management solution for new generation computing processors. It has a programmable power save interface (PSI) and is able to operate in 1-phase diode emulation mode to obtain high efficiency in light-load condition. Operating in high switching frequency up to 800 kHz allows employing small size inductor and capacitors. The part is able to support all-ceramic-capacitor applications.

Features

- 3.6 V to 24 V Input Voltage Range
- Output Voltage up to 2.0 V with PWM VID Interface
- Differential Output Voltage Sense
- Integrated Gate Drivers
- 200 kHz ~ 800 kHz Switching Frequency
- Power Saving Interface (PSI)
- Support both 3.3 V and 1.8 V VID
- Power Good Output
- Programmable Over Current Protection
- Over Voltage Protection
- Under Voltage Protection
- Thermal Shutdown Protection
- QFN20, 3x3 mm, 0.4 mm Pitch Package

Typical Applications

- GPU and CPU Power
- Graphics Card Applications
- Desktop and Notebook Applications



ON Semiconductor®

www.onsemi.com



QFN20
CASE 485BC

MARKING DIAGRAM

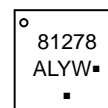

81278 = Specific Device Code
A = Assembly Location
L = Wafer Lot
Y = Year
W = Work Week
▪ = Pb-Free Package

(Note: Microdot may be in either location)

PIN CONNECTIONS

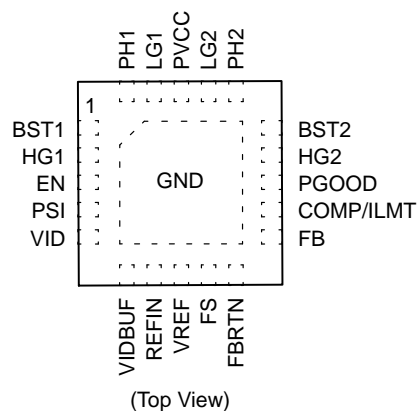

ORDERING INFORMATION

Device	Package	Shipping†
NCP81278MNTXG	QFN20 (Pb-Free)	4,000 / Tape & Reel

†For information on tape and reel specifications, including part orientation and tape sizes, please refer to our Tape and Reel Packaging Specification Brochure, BRD8011/D.

NCP81278

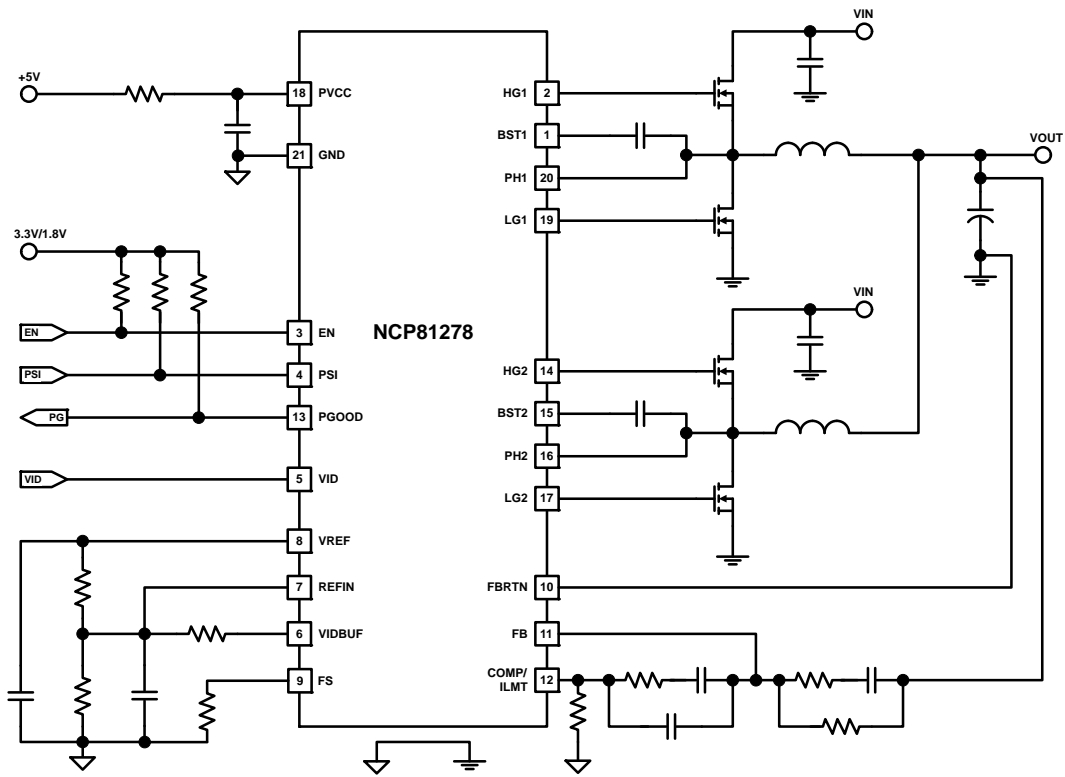

Figure 1. Typical Application Circuit with PWM-VID Interface

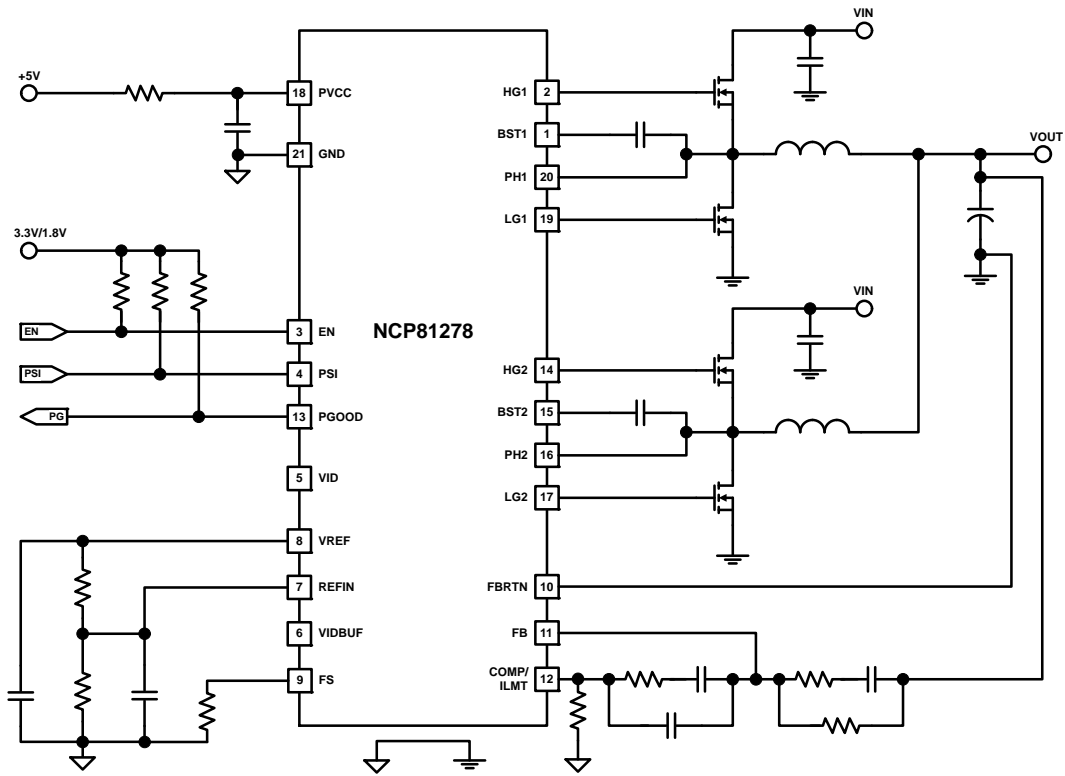

Figure 2. Typical Application Circuit without PWM-VID Interface

NCP81278

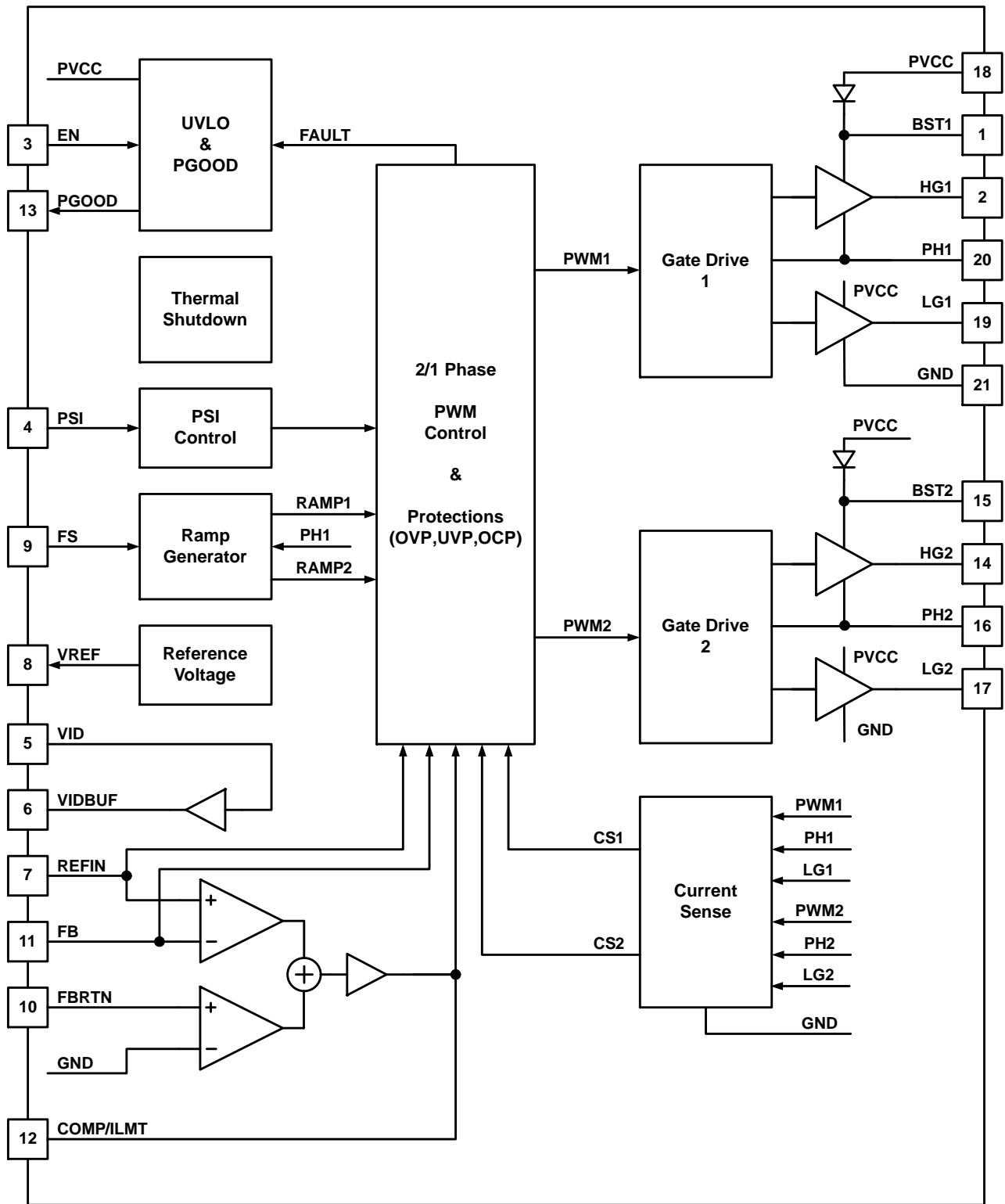

Figure 3. Functional Block Diagram

NCP81278

PIN DESCRIPTION

Pin	Name	Type	Description
1	BST1	Analog Power	Bootstrap 1. Provides bootstrap voltage for the high-side gate drive of phase 1. A 0.1 μF ~ 1 μF ceramic capacitor is required from this pin to PH1 (pin 20).
2	HG1	Analog Output	High-Side Gate 1. Directly connected with the gate of the high-side power MOSFET of phase 1.
3	EN	Logic Input	Enable. Logic high enables the device and logic low makes the device in standby mode.
4	PSI	Logic Input	Power Saving Interface. Logic high enables 2-phase CCM operation, mid level enables 1-phase CCM operation, and logic low enables 1-phase auto CCM/DCM operation.
5	VID	Logic Input	Voltage ID. Voltage ID input from processor.
6	VIDBUF	Analog Output	Voltage ID Buffer. VID PWM pulse output from an internal buffer.
7	REFIN	Analog Input	Reference Input. Reference voltage input for output voltage regulation. The pin is connected to a non-inverting input of internal error amplifier.
8	VREF	Analog Output	Output Reference Voltage. Precise 2 V reference voltage output. A 10 nF ceramic capacitor is required from this pin to GND.
9	FS	Analog Input	Frequency Selection. A resistor from this pin to ground programs switching frequency.
10	FBRTN	Analog Input	Voltage Feedback Return Input. An inverting input of internal error amplifier.
11	FB	Analog Input	Feedback. An inverting input of internal error amplifier.
12	COMP/ILMT	Analog Output	Compensation / ILMT. Output pin of error amplifier. A resistor may be applied between this pin and GND to program OCP threshold.
13	PGOOD	Logic Output	Power GOOD. Open-drain output. Provides a logic high valid power good output signal, indicating the regulator's output is in regulation window.
14	HG2	Analog Output	High-Side Gate 2. Connected with the gate of the high-side power MOSFET in phase 2.
15	BST2	Analog Power	Bootstrap 2. Provides bootstrap voltage for the high-side gate drive of phase 2. A 0.1 μF ~ 1 μF ceramic capacitor is required from this pin to PH2 (pin 16).
16	PH2	Analog Input	Phase Node 2. Connected to interconnection between high-side MOSFET and low-side MOSFET in phase 2.
17	LG2	Analog Output	Low-Side Gate 2. Connected with the gate of the low-side power MOSFET in phase 2.
18	PVCC	Analog Power	Voltage Supply of Controller and Gate Driver. Power supply input pin of control circuit and internal gate drivers. A 4.7 μF or larger ceramic capacitor bypasses this input to ground. This capacitor should be placed as close as possible to this pin.
19	LG1	Analog Output	Low-Side Gate 1. Connected with the gate of the low-side power MOSFET in phase 1.
20	PH1	Analog Input	Phase Node 1. Connected to interconnection between high-side MOSFET and low-side MOSFET in phase 1.
21	THERM/GND	Analog Ground	Thermal Pad and Ground. Common ground of internal control circuits and gate drivers. Must be connected to the system ground.

NCP81278

MAXIMUM RATINGS

Rating	Symbol	Value		Unit
		Min	Max	
PH to GND	V_{PH}	-2 -8 (<100 ns)	30	V
Supply Voltage PVCC to GND	V_{PVCC}	-0.3	6.5	V
BST to GND	V_{BST_GND}	-0.3	35	V
BST to PH	V_{BST_PH}	-0.3	6.5	V
HG to PH	V_{HG}	-0.3 -2 (<200 ns)	BST+0.3	V
LG to GND	V_{LG}	-0.3 -2 (<200 ns)	MIN (PVCC+0.3, 6.5)	V
FBRTN to GND	V_{FBRTN}	-0.3	0.3	V
Other Pins to GND		-0.3	MIN (VCC+0.3, 6.5)	V
Human Body Model (HBM) ESD Rating are (Note 1)	ESD HBM		2000	V
Machine Model (MM) ESD Rating are (Note 1)	ESD MM		200	V
Latch up Current: (Note 2) All pins, except digital pins Digital pins	I_{LU}	-100 -10	100 10	mA
Operating Junction Temperature Range (Notes 3 and 4)	T_J	-40	125	°C
Operating Ambient Temperature Range	T_A	-40	100	°C
Storage Temperature Range	T_{STG}	-40	150	°C
Thermal Resistance Junction to Top Case (Note 5)	$R_{\psi JC}$	5		°C/W
Thermal Resistance Junction to Board (Note 5)	$R_{\psi JB}$	4		°C/W
Thermal Resistance Junction to Ambient (Note 4)	$R_{\theta JA}$	40		°C/W
Power Dissipation (Note 6)	P_D	2.5		W
Moisture Sensitivity Level (Note 7)	MSL	1		-

Stresses exceeding those listed in the Maximum Ratings table may damage the device. If any of these limits are exceeded, device functionality should not be assumed, damage may occur and reliability may be affected.

1. This device is ESD sensitive. Handling precautions are needed to avoid damage or performance degradation.
2. Latch up Current per JEDEC standard: JESD78 class II.
3. The thermal shutdown set to 150°C (typical) avoids potential irreversible damage on the device due to power dissipation.
4. JEDEC standard JESD 51-7 (1S2P Direct-Attach Method) with 0 LFM.
5. JEDEC standard JESD 51-7 (1S2P Direct-Attach Method) with 0 LFM. It is for checking junction temperature using external measurement.
6. The maximum power dissipation (P_D) is dependent on input voltage, maximum output current and external components selected. $T_{ambient} = 25^\circ\text{C}$, $T_{junc_max} = 125^\circ\text{C}$, $P_D = (T_{junc_max} - T_{amb}) / \theta_{JA}$.
7. Moisture Sensitivity Level (MSL): 1 per IPC/JEDEC standard: J-STD-020A.

NCP81278

ELECTRICAL CHARACTERISTICS ($V_{IN} = 12\text{ V}$, $V_{PVCC} = 5\text{ V}$, $V_{REFIN} = 1.0\text{ V}$, $V_{PSI} = 1.8\text{ V}$, typical values are referenced to $T_A = T_J = 25^\circ\text{C}$, Min and Max values are referenced to $T_A = T_J = -40^\circ\text{C}$ to 100°C , unless other noted.)

Characteristics	Test Conditions	Symbol	Min	Typ	Max	Units
-----------------	-----------------	--------	-----	-----	-----	-------

SUPPLY VOLTAGE

VIN Supply Voltage Range	(Note 8)	V_{IN}	3.6	12	24	V
PVCC Supply Voltage Range	(Note 8)	V_{PCC}	4.5	5	5.5	V
PVCC Under-Voltage (UVLO) Threshold	PVCC falling	V_{CCUV-}	4.0	4.11	4.2	V
PVCC OK Threshold	PVCC rising	V_{CCOK}	4.2	4.31	4.4	V

SUPPLY CURRENT

PVCC Quiescent Current	EN high, no switching	PS0	I_{CC}	–	4.6	7.5	mA
		PS1		–	4.65	7.5	
		PS2		–	4.59	7.5	
PVCC Shutdown Current	EN low	I_{sdPCC}	–	27	50	μA	

SWITCHING FREQUENCY SETTING

PS0 Switching Frequency Range	(Note 8)	F_{SW}	200		800	kHz
FS Voltage	RFS = 39.2 k Ω	V_{FS}		2.0		V

VOLTAGE REFERENCE

VREF Reference Voltage	$I_{REF} = 1\text{ mA}$	V_{VREF}	1.98	2.0	2.02	V
------------------------	-------------------------	------------	------	-----	------	---

PWM MODULATION

Minimum On Time	(Note 8)	T_{on_min}		50		ns
Minimum Off Time	(Note 8)	T_{off_min}		250		ns

VOLTAGE ERROR AMPLIFIER

Open-Loop DC Gain	(Note 8)	$GAIN_{EA}$		80		dB
Unity Gain Bandwidth	(Note 8)	GBW_{EA}		20		MHz
Slew Rate	(Note 8)	SR_{COMP}		20		V/ μs
COMP Voltage Swing	$I_{COMP(source)} = 2\text{ mA}$ $I_{COMP(sink)} = 2\text{ mA}$	$V_{maxCOMP}$	3.1	3.4	–	V
		$V_{minCOMP}$	–	0.95	1.10	V
FB, REFIN Bias Current	$V_{FB} = V_{REFIN} = 1.0\text{ V}$	I_{FB}	–400		400	nA
Input Offset Voltage	$V_{osEA} = V_{REFIN} - V_{FB}$ (Note 8) $T_J = 25^\circ\text{C}$ $T_J = -40^\circ\text{C}$ to 100°C	V_{osEA}	–0.65 –8.5		0.65 8.5	mV
REFIN Discharge Switch ON-Resistance	$I_{REFIN(sink)} = 2\text{ mA}$			6.91		Ω

CURRENT-SENSE AMPLIFIER

Closed-Loop DC Gain		$GAIN_{CA}$		–5.0		V/V
–3 dB Gain Bandwidth	(Note 8)	BW_{CA}		10		MHz
Input Offset Voltage	$V_{osCS} = V_{PH} - V_{GND}$ (Note 8)	V_{osCS}	–500	–	500	μV

ENABLE

EN High Threshold		V_{highEN}	1.5	–	–	V
EN Low Threshold		V_{lowEN}	–	–	0.7	V
EN Hysteresis		V_{hysEN}		350		mV
EN Input Bias Current	External 1 K pull-up to 3.3 V	I_{biasEN}	–	–	1.0	μA

POWER SAVE INPUT

Connected to PVCC	PSH: 2-Phase Auto CCM/DCM Mode		$V_{PVCC} - 0.25$			V
High Threshold	PS0: 2-Phase CCM Mode	$V_{highPSI}$	1.5			V
Mid Voltage level	PS1: 1-Phase CCM Mode	V_{midPSI}	0.6		1.2	V

8. Guaranteed by design, not tested in production.

NCP81278

ELECTRICAL CHARACTERISTICS ($V_{IN} = 12\text{ V}$, $V_{PVCC} = 5\text{ V}$, $V_{REFIN} = 1.0\text{ V}$, $V_{PSI} = 1.8\text{ V}$, typical values are referenced to $T_A = T_J = 25^\circ\text{C}$, Min and Max values are referenced to $T_A = T_J = -40^\circ\text{C}$ to 100°C , unless other noted.)

Characteristics	Test Conditions	Symbol	Min	Typ	Max	Units
-----------------	-----------------	--------	-----	-----	-----	-------

POWER SAVE INPUT

Low Threshold	PS2: 1-Phase Auto CCM/DCM Mode	V_{lowPSI}			0.3	V
Internal Pull High Resistance	PSI to internal 2.0 V			110		k Ω
Internal Pull Low Resistance	PSI to GND			90		k Ω

SOFT START and PGOOD

Vout Startup Delay	From EN to Vout Start up (Note 8)			250		μs
Vout Startup Slew Rate	(Note 8)			0.643		V/ms
PGOOD Startup Delay	From EN to PGOOD assertion				2.0	ms
PGOOD Shutdown Delay	From EN to PGOOD de-assertion			125		ns
PGOOD Low Voltage	$I_{PGOOD} = 4\text{ mA}$ (sink)	V_{IPGOOD}	-	-	0.3	V
PGOOD Leakage Current	PGOOD = 5 V	$I_{lkgPGOOD}$	-	-	1.0	μA

PROTECTION

Current Limit Threshold	Measured from GND to PHx (R_{ILMT} (1%) is connected from COMP to GND)	$R_{ILMT} = \text{open}$	V_{OCTH}	80	91	102	mV
		$R_{ILMT} = 75.0\text{ k}$		100	112	124	
		$R_{ILMT} = 56.2\text{ k}$		123	137	151	
		$R_{ILMT} = 33.2\text{ k}$		164	183	201	
		$R_{ILMT} = 11\text{ k}$		OCP is disabled			-
Source Current of OCP Programming	Source out COMP pin	I_{ILMT}	9.5	10	10.5	μA	
Fast Under Voltage Protection (FUVP) Threshold	Voltage from FB to GND		0.15	0.2	0.25	V	
Fast Under Voltage Protection (FUVP) Delay	(Note 8)			1.0		μs	
Slow Under Voltage Protection (SUVP) Threshold	Voltage from COMP to GND			3.0		V	
Slow Under Voltage Protection (SUVP) Delay	(Note 8)			50		μs	
Over Voltage Protection (OVP) Threshold	Voltage from FB to GND		1.85	2.0	2.15	V	
Over Voltage Protection (OVP) Delay	(Note 8)			1.0		μs	
Over Temperature Protection (OTP) Threshold	(Note 8)	T_{sd}	140	150		$^\circ\text{C}$	
Recovery Temperature Threshold	(Note 8)	T_{rec}		125		$^\circ\text{C}$	
Over Temperature Protection (OTP) Delay	(Note 8)			125		ns	

OUTPUT DISCHARGE

Output Discharge Resistance per Phase	Measured from PHx to GND when EN is low (Note 8)	$R_{dischrg}$		5		k Ω
---------------------------------------	--	---------------	--	---	--	------------

PWM-VID BUFFER

Input High Threshold		$V_{highVID}$	1.5			V
Input Mid Voltage level		V_{midVID}	0.6		1.2	V
Input Low Threshold		V_{lowVID}			0.3	V
Internal Pull High Resistance in VID Pin	VID to internal 2.0 V			110		k Ω
Internal Pull Low Resistance in VID Pin	VID to GND			90		k Ω
3-State Shut-Off Time		$T_{D_HOLD-OFF}$		350		ns
Buffer Output Rise Time		T_r		3		ns

8. Guaranteed by design, not tested in production.

NCP81278

ELECTRICAL CHARACTERISTICS ($V_{IN} = 12\text{ V}$, $V_{PVCC} = 5\text{ V}$, $V_{REFIN} = 1.0\text{ V}$, $V_{PSI} = 1.8\text{ V}$, typical values are referenced to $T_A = T_J = 25^\circ\text{C}$, Min and Max values are referenced to $T_A = T_J = -40^\circ\text{C}$ to 100°C , unless other noted.)

Characteristics	Test Conditions	Symbol	Min	Typ	Max	Units
-----------------	-----------------	--------	-----	-----	-----	-------

PWM-VID BUFFER

Buffer Output Fall Time		T_f		3		ns
Propagation Delay	$T_{pd} = T_{pHL} = T_{pLH}$	T_{pd}		8		ns

INTERNAL HIGH-SIDE GATE DRIVE

Pull-High Drive ON Resistance	$V_{BST} - V_{PH} = 5\text{ V}$, $I_{HG} = 50\text{ mA}$ (source)	R_{DRV_HH}	-	2.5	-	Ω
Pull-Low Drive ON Resistance	$V_{BST} - V_{PH} = 5\text{ V}$, $I_{HG} = 50\text{ mA}$ (sink)	R_{DRV_HL}	-	1.0	-	Ω
HG Propagation Delay Time	From LG off to HG on	T_{pdHG}		27		ns

INTERNAL LOW-SIDE GATE DRIVE

Pull-High Drive ON Resistance	$V_{PVCC} - V_{GND} = 5\text{ V}$, $I_{LG} = 50\text{ mA}$ (source)	R_{DRV_LH}	-	1.5	-	Ω
Pull-Low Drive ON Resistance	$V_{PVCC} - V_{GND} = 5\text{ V}$, $I_{LG} = 50\text{ mA}$ (sink)	R_{DRV_LL}	-	0.6	-	Ω
LG Propagation Delay Time	From HG off to LG on	T_{pdLG}		26		ns

BOOTSTRAP

On Resistance of Rectifier Switch	$V_{PVCC} = 5\text{ V}$, $I_d = 2\text{ mA}$, $T_A = 25^\circ\text{C}$	R_{BST}	30	54	75	Ω
Rectifier Switch Leakage Current	$V_{PVCC} = 5\text{ V}$, $EN = 0\text{ V}$	I_{lkgBST}	-	-	3	μA

8. Guaranteed by design, not tested in production.

Product parametric performance is indicated in the Electrical Characteristics for the listed test conditions, unless otherwise noted. Product performance may not be indicated by the Electrical Characteristics if operated under different conditions.

DETAILED DESCRIPTION

General

The NCP81278, a 2-phase synchronous buck controller, integrates gate drivers and PWM VID interface in a QFN-20 package and provides a compact-footprint power management solution for new generation computing processors. It receives power save input (PSI) from processors and operates in 1-phase diode emulation mode to obtain high efficiency in light-load condition. Operating in high switching frequency up to 800 kHz allows employing small size inductor and capacitors. Introduction of multi-phase current-mode RPM control results in fast transient response and good dynamic current balance. It is able to support all-ceramic-capacitor applications.

Operation Modes

The NCP81278 has total 4 power operation modes responding to PSI levels as shown in Table 1. The operation modes can be changed on the fly between two modes in an allowed mode-change combination. There are only two allowed mode-change combinations, which is either a combination of PS0 and PS2 or a combination of PS1 and PS2. In 1-phase operation, no switching in phase 2.

Table 1. POWER SAVING INTERFACE (PSI) CONFIGURATIONS

PSI Level	Power Mode	Phase Configuration
Connected to PVCC	PSH	2-Phase, Auto CCM/DCM
High	PS0	2-Phase, CCM
Intermediate	PS1	1-Phase, CCM
Low	PS2	1-Phase, Auto CCM/DCM

The NCP81278 is also able to support pure single-phase applications without a need to stuff components for phase 2. In this configuration, the four pins including BST2, HG2, LG2, and PH2 can be float, but make sure the voltage at PSI pin is never in high level.

Remote Voltage Sense

A high performance and high input impedance differential error amplifier, as shown in Figure 4, provides an accurate sense for the output voltage of the regulator. The

output voltage and FBRTN inputs should be connected to the regulator’s output voltage sense points via a Kelvin-sense pair. The output voltage sense signal goes through a compensation network and into the inverting input (FB pin) of the error amplifier. The non-inverting input of the error amplifier is connected to the reference input (REFIN pin).

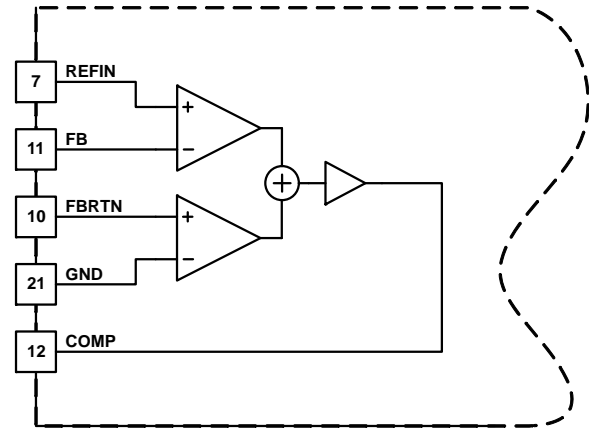

Figure 4. Differential Error Amplifier

PWM VID

The NCP81278 receives a PWMVID signal at VID pin for the output voltage regulation. Figure 5 shows the PWMVID dynamic voltage control circuit diagram. The VID signal is decoded internally and passed to the VID buffer output (VIDBUF), where the duty cycle is converted to a corresponding PWM signal switching between 0 V and 2 V. The VIDBUF high level is derived from a precise 2.0 V reference voltage VREF. The VIDBUF signal is then filtered through an external low-pass filter constructed by R_VIDBUF and C_REFIN. The filtered output is connected to REFIN pin. REFIN is the voltage reference of the output voltage regulator. The dynamic range of the circuit is determined by the external resistor network. The resistor network and capacitor C_REFIN function as a filter for the PWMVID signal, and will affect ripple voltage and transition slew rate in REFIN signal.

NCP81278

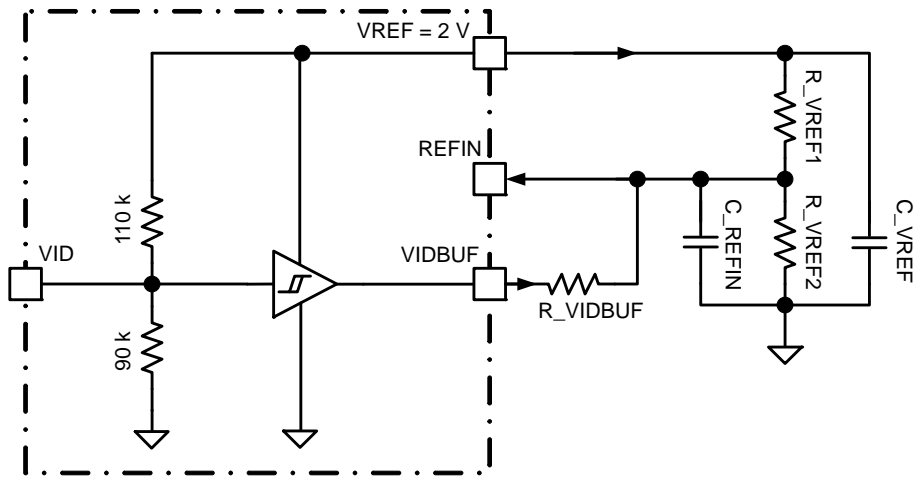

Figure 5. PWM VID Interface

Switching Frequency

Switching frequency is programmed by a resistor R_{FS} applied from the FS pin to ground. The typical frequency range is from 200 kHz to 800 kHz. The FS pin provides approximately 2 V out and the source current is mirrored into the internal ramp generator. The switching frequency in 2-phase CCM operation can be estimated by

$$F_{SW(kHz)} = 7510 \cdot R_{FS(k\Omega)}^{-0.799} \quad (\text{eq. 1})$$

To reduce output ripple in 1-phase operation, the switching frequency in 1-phase CCM operation is set to be

higher than 2-phase CCM operation, which can be estimated by

$$F_{SW(kHz)} = 6721 \cdot R_{FS(k\Omega)}^{-0.737} \quad (\text{eq. 2})$$

Figure 6 shows a measurement based on a typical application under condition of $V_{in} = 20$ V, $V_{out} = 0.9$ V, $I_{out} = 10$ A for 1-phase operation and $I_{out} = 20$ A for 2-phase operation. It can be also found that the lower R_{dson} of the low-side MOSFETs the smaller frequency difference between 2-phase mode and 1-phase mode.

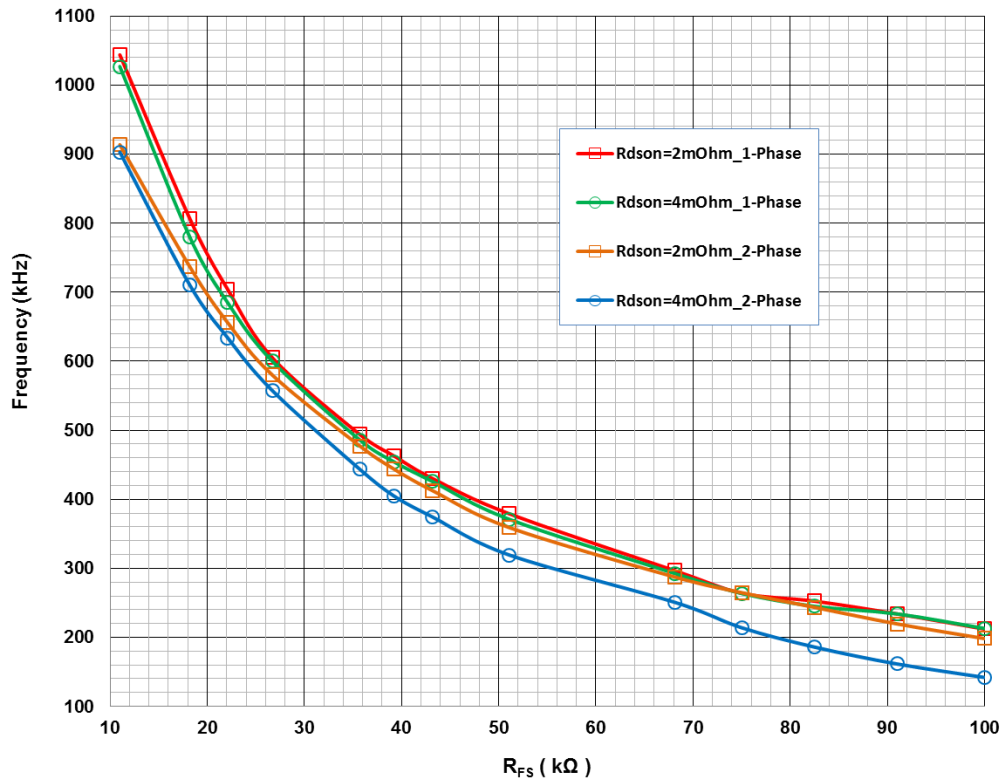

Figure 6. Switching Frequency Programmed by Resistor R_{FS} at FS Pin

Soft Start

The NCP81278 has a soft start function. The output starts to ramp up following a system reset period after the device is enabled. The device is able to start up smoothly under an output pre-biased condition without discharging the output before ramping up.

REFIN Discharge

An internal switch in REFIN pin starts to short REFIN to GND just after EN is pulled high and it turns off just before the beginning of the soft start. The typical on resistance of the switch is 6.91 Ω .

Output Discharge in Shut Down

The NCP81278 has an output discharge function when the device is in shutdown mode. The resistors (5 k Ω per phase) from PH node to GND in both phases are active to discharge the output capacitors.

Over Current Protection

The NCP81278 protects converters from over current. The current through each phase is monitored by voltage sensing from phase node PHx to GND pin. The sense signal is compared to an internal voltage threshold. Once over load happens, the inductor current is limited to an average current per phase, which can be estimated by

$$I_{LMT(phase)} = \frac{V_{thOC}}{R_{DS(phase)}} \quad (eq. 3)$$

where $R_{DS(phase)}$ is a total on conduction resistance of low-side MOSFETs per phase. Normally, a continuous over load event leads to a voltage drop in the output voltage and possible to eventually trip under voltage protection.

The over-current threshold can be externally programmed by adding a 1% tolerance resistor between COMP pin and GND. The selectable thresholds can be found in the electrical table. To assure accurate resistance detection, the total capacitance from COMP pin to FB pin should be less than 330 pF.

Under Voltage Protection

There are two under voltage protections implemented in the NCP81278, which are fast under voltage protection and slow under voltage protection.

Fast under voltage protection (FUVP) protects converters in case of an extreme short circuit in output by monitoring FB voltage. Once FB voltage drops below 0.2 V for more than 1 μ s, the NCP81278 latches off, both the high-side MOSFETs and the low-side MOSFETs in all phases are turned off. The fault remains set until the system has either VCC or EN toggled state. The FUVP function is disabled in soft start.

Slow under voltage protection (SUVP) of the NCP81278 is based on voltage detection at COMP pin. In normal operation, COMP level is below 2.5 V. When the output voltage drops below REFIN voltage for long time and COMP rises to be over 3 V, an internal UV fault timer will be triggered. If the fault still exists after 50 μ s, the NCP81278 latches off, both the high-side MOSFETs and the low-side MOSFETs in all phases are turned off. The fault remains set until the system has either VCC or EN toggled state.

Over Voltage Protection

Over voltage protection of the NCP81278 is based on voltage detection at FB pin. Once FB voltage is over 2 V for more than 1 μ s, all the high-side MOSFETs are turned off and all the low-side MOSFETs are latched on. The NCP81278 latches off until the system has either VCC or EN has toggled state.

Thermal Shutdown

The NCP81278 has a thermal shutdown protection to protect the device from overheating when the die temperature exceeds 150°C. Once the thermal protection is triggered, the fault state can be ended by re-applying VCC and/or EN if the temperature drops down below 125°C.

LAYOUT GUIDELINES

Electrical Layout Considerations

Good electrical layout is a key to make sure proper operation, high efficiency, and noise reduction.

- **Power Paths:** Use wide and short traces for power paths to reduce parasitic inductance and high-frequency loop area. It is also good for efficiency improvement.
- **Power Supply Decoupling:** The power MOSFET bridges should be well decoupled by input capacitors and input loop area should be as small as possible to reduce parasitic inductance, input voltage spike, and noise emission. Place decoupling caps as close as possible to the controller PVCC pin.
- **Output Decoupling:** The output capacitors should be as close as possible to the load like a GPU. If the load is distributed, the capacitors should also be distributed and generally placed in greater proportion where the load is more dynamic.
- **Switching Nodes:** Switching nodes between HS and LS MOSFETs should be copper pours to carry high current and dissipate heat, but compact because they are also noise sources.
- **Gate Drive:** All the gate drive traces such as HGx, LGx, PHx, and BSTx should be short, straight as possible, and not too thin. The bootstrap cap and an option resistor need to be very close and directly connected between BSTx pin and PHx pin.
- **Ground:** It would be good to have separated ground planes for PGND and GND and connect the two planes at one point. PGND plane is an isolation plane between noisy power traces and all the sensitive control circuits. Directly connect the exposed pad (GND pin) to GND ground plane through vias. The analog control circuits should be surrounded by GND ground plane. GND ground plane is connected to PGND plane by single joint with low impedance.

- **Voltage Sense:** Use Kelvin sense pair and arrange a “quiet” path for the differential output voltage sense.
- **Current Sense:** The NCP81278 senses phase currents by monitoring voltages from phase nodes PHx to the common ground GND pin. PGND ground plane should be well underneath PHx trances. To get better current balance between the two phases, try to make a layout as symmetrical as possible and balance the current flow in PGND plane for the two phases.
- **Compensation Network:** The compensation network should be close to the controller. Keep FB trace short to minimize their capacitance to GND.
- **PWM VID Circuit:** The PWM VID is a high slew-rate digital signal from GPU to the controller. The trace routing of it should be done to avoid noise coupling from the switching node and to avoid coupling to other sensitive analog circuit as well. The RC network of the PWM VID circuit needs to be close to the controller. A 10 nF ceramic cap is connected from VREF pin to GND plane, and another small ceramic cap is connected from REFIN pin to GND plane.

Thermal Layout Considerations

Good thermal layout helps high power dissipation from a small-form factor VR with reduced temperature rise.

- The exposed pads of the controller and power MOSFETs must be well soldered on the board.
- A four or more layers PCB board with solid ground planes is preferred for better heat dissipation.
- More vias are welcome to be underneath the exposed pads and surrounding the power devices to connect the inner ground layers to reduce thermal resistances.
- Use large area copper pour to help thermal conduction and radiation.
- Try distributing multiple heat sources to reduce temperature rise in hot spots.

NCP81278

PACKAGE DIMENSIONS

QFN20 3x3, 0.4P
CASE 485BC
ISSUE O

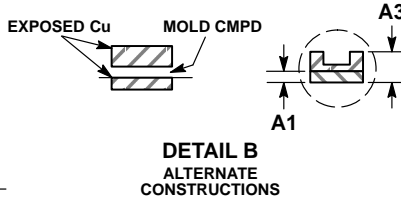
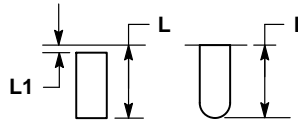
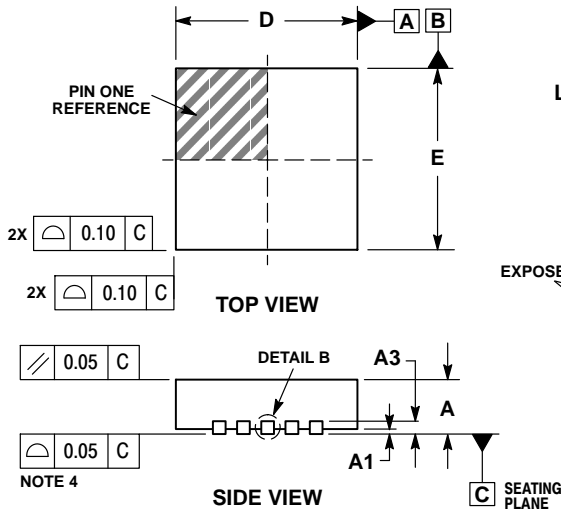

- NOTES:
1. DIMENSIONING AND TOLERANCING PER ASME Y14.5M, 1994.
 2. CONTROLLING DIMENSION: MILLIMETERS.
 3. DIMENSION b APPLIES TO PLATED TERMINAL AND IS MEASURED BETWEEN 0.15 AND 0.30mm FROM TERMINAL.
 4. COPLANARITY APPLIES TO THE EXPOSED PAD AS WELL AS THE TERMINALS.

DIM	MILLIMETERS	
	MIN	MAX
A	0.80	1.00
A1	---	0.05
A3	0.20 REF	
b	0.15	0.25
D	3.00 BSC	
D2	1.70	1.90
E	3.00 BSC	
E2	1.70	1.90
e	0.40 BSC	
K	0.30 REF	
L	0.20	0.40
L1	0.00	0.15

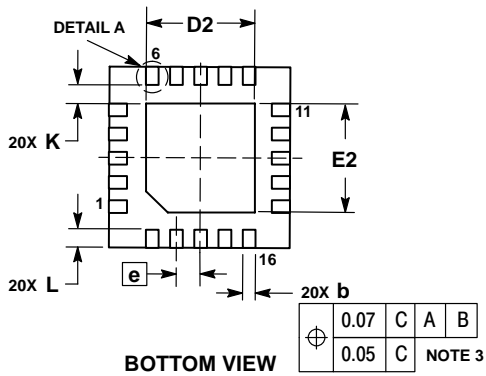

SOLDERING FOOTPRINT*

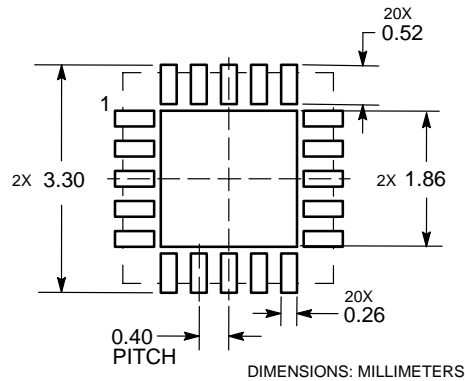

*For additional information on our Pb-Free strategy and soldering details, please download the ON Semiconductor Soldering and Mounting Techniques Reference Manual, SOLDERRM/D.

ON Semiconductor and the are registered trademarks of Semiconductor Components Industries, LLC (SCILLC) or its subsidiaries in the United States and/or other countries. SCILLC owns the rights to a number of patents, trademarks, copyrights, trade secrets, and other intellectual property. A listing of SCILLC's product/patent coverage may be accessed at www.onsemi.com/site/pdf/Patent-Marketing.pdf. SCILLC reserves the right to make changes without further notice to any products herein. SCILLC makes no warranty, representation or guarantee regarding the suitability of its products for any particular purpose, nor does SCILLC assume any liability arising out of the application or use of any product or circuit, and specifically disclaims any and all liability, including without limitation special, consequential or incidental damages. "Typical" parameters which may be provided in SCILLC data sheets and/or specifications can and do vary in different applications and actual performance may vary over time. All operating parameters, including "Typicals" must be validated for each customer application by customer's technical experts. SCILLC does not convey any license under its patent rights nor the rights of others. SCILLC products are not designed, intended, or authorized for use as components in systems intended for surgical implant into the body, or other applications intended to support or sustain life, or for any other application in which the failure of the SCILLC product could create a situation where personal injury or death may occur. Should Buyer purchase or use SCILLC products for any such unintended or unauthorized application, Buyer shall indemnify and hold SCILLC and its officers, employees, subsidiaries, affiliates, and distributors harmless against all claims, costs, damages, and expenses, and reasonable attorney fees arising out of, directly or indirectly, any claim of personal injury or death associated with such unintended or unauthorized use, even if such claim alleges that SCILLC was negligent regarding the design or manufacture of the part. SCILLC is an Equal Opportunity/Affirmative Action Employer. This literature is subject to all applicable copyright laws and is not for resale in any manner.

PUBLICATION ORDERING INFORMATION

LITERATURE FULFILLMENT:
Literature Distribution Center for ON Semiconductor
19521 E. 32nd Pkwy, Aurora, Colorado 80011 USA
Phone: 303-675-2175 or 800-344-3860 Toll Free USA/Canada
Fax: 303-675-2176 or 800-344-3867 Toll Free USA/Canada
Email: orderlit@onsemi.com

N. American Technical Support: 800-282-9855 Toll Free
USA/Canada
Europe, Middle East and Africa Technical Support:
Phone: 421 33 790 2910
Japan Customer Focus Center
Phone: 81-3-5817-1050

ON Semiconductor Website: www.onsemi.com
Order Literature: <http://www.onsemi.com/orderlit>

For additional information, please contact your local Sales Representative

Mouser Electronics

Authorized Distributor

Click to View Pricing, Inventory, Delivery & Lifecycle Information:

[ON Semiconductor:](#)

[NCP81278MNTXG](#) [NCP81278DMNTXG](#)