

# Magnetically Coded Non Contact Switch (MC2) Installation Instructions



440N-Z21W1PA	3 Metre Cable
440N-Z21W1PB	10 Metre Cable
440N-Z21W1PH	8-Pin micro (M12) Pigtail

## Certifications



**IMPORTANT:**  
**SAVE THESE INSTRUCTIONS FOR FUTURE REFERENCE**

**Note:** Refer to Technical Specifications for Certification information and ratings.

## 2 Magnetically Coded Non Contact Switch Installation Instructions

<b>ENGLISH:</b>	This instruction sheet is available in multiple languages at <a href="http://www.rockwellautomation.com/literature">www.rockwellautomation.com/literature</a> . Select publication language and type "SensaGuard" in the search field.
<b>GERMAN:</b>	Dieses Instruktionsblatt kann in mehreren Sprachen unter <a href="http://www.rockwellautomation.com/literature">www.rockwellautomation.com/literature</a> gelesen werden. Bitte Ihre Sprache anwählen und "SensaGuard" im Suchfeld eintippen.
<b>FRENCH:</b>	Ces instructions sont disponibles dans différentes langues à l'adresse suivante <a href="http://www.rockwellautomation.com/literature">www.rockwellautomation.com/literature</a> . Sélectionner la langue puis taper "SensaGuard" dans le champ de recherche.
<b>ITALIAN:</b>	La presente scheda d'istruzione è disponibile in varie lingue sul sito <a href="http://www.rockwellautomation.com/literature">www.rockwellautomation.com/literature</a> . Selezionare la lingua desiderata e digitare "SensaGuard" nel campo di ricerca.
<b>SPANISH:</b>	Puede encontrar esta hoja de instrucciones en varios idiomas en <a href="http://www.rockwellautomation.com/literature">www.rockwellautomation.com/literature</a> . Seleccione el idioma de publicación y escriba "SensaGuard" en el campo de búsqueda.
<b>PORTUGUESE:</b>	Esta folha de instruções está disponível em várias línguas em <a href="http://www.rockwellautomation.com/literature">www.rockwellautomation.com/literature</a> . Selecione a língua de publicação e entre com "SensaGuard" no espaço de busca.
<b>POLISH:</b>	Ta kartka z instrukcjami jest dostępna w wielu językach na stronie: <a href="http://www.rockwellautomation.com/literature">www.rockwellautomation.com/literature</a> . Wybierz język publikacji i wpisz w polu poszukiwania "SensaGuard".

### Table of Contents

<b>Installation Instructions</b>	<b>3</b>
<b>Warnings</b>	<b>3</b>
<b>Technical Specification</b>	<b>3</b>
<b>Safety Ratings</b>	<b>3</b>
<b>Operating Characteristics</b>	<b>3</b>
<b>Physical Characteristics</b>	<b>3</b>
<b>Outputs</b>	<b>3</b>
<b>Response Time</b>	<b>3</b>
<b>Environmental</b>	<b>3</b>
<b>Protection</b>	<b>4</b>
<b>Dimensions</b>	<b>4</b>
<b>Mode of Operation</b>	<b>4</b>
<b>Status Indicators</b>	<b>4</b>
<b>Mounting Information</b>	<b>4</b>
<b>Nut Torque Specification</b>	<b>4</b>
<b>Minimum Distance Between Sensors</b>	<b>5</b>
<b>Misalignment Curve</b>	<b>5</b>
<b>Diagnostics</b>	<b>6</b>
<b>Troubleshooting</b>	<b>6</b>
<b>Wiring Diagram</b>	<b>7</b>
<b>Recommended Mating Cable</b>	<b>7</b>
<b>Power Supply Requirements</b>	<b>8</b>
<b>Approved Relays</b>	<b>8</b>
<b>Application Wiring Examples</b>	<b>9</b>
<b>Maintenance</b>	<b>12</b>
<b>Repair</b>	<b>12</b>
<b>Declaration of Conformity</b>	<b>12</b>

## 1. Installation Instructions

Installation must be in accordance with the following steps and stated specifications and should be carried out by suitable competent personnel. The unit is not to be used as a mechanical stop. Guard stops and guides must be fitted. Adherence to the recommended maintenance instructions forms part of the warranty.

This device is intended to be part of the safety related control system of a machine. Before installation, a risk assessment should be performed to determine whether the specifications of this device are suitable for all foreseeable operational and environmental characteristics of the machine to which it is to be fitted. Refer to Technical Specifications for Certification information and ratings.

**⚠ ATTENTION:** The presence of spare actuators compromise the integrity of the safety systems. Personal injury or death, property damage or economic loss can result. Appropriate management controls, working procedures and alternative protective measures should be introduced to control their use and availability.

**⚠ WARNING:** Do not defeat, tamper, remove or bypass this unit. Severe injury to personnel could result.

## 2. Technical Specification

### 2.1 Safety Ratings

Standards	EN1088,ISO14119, IEC/EN60947-5-3
Safety Classification	Dual contacts suitable for Cat.3 or 4 systems
Functional Safety Data	B10d: > 2 x 10 <sup>6</sup> operations at min. PFH <sub>p</sub> : > 3 x 10 <sup>7</sup> MTTFd: > 385 years
Usable for ISO 13849-1:2006 and IEC 62061. Data other than B10d is based on: Usage rate of 10p/10mins., 24 hrs/day, 360 days/year, representing 51840 operations per year.	Dual channel interlock may be suitable for performance levels PLe or PLd (according to ISO 13849-1:2006) and for use in SIL2 or SIL3 systems (according to IEC 62061) depending on application characteristics.
<b>Note:</b> For up-to-date information, visit <a href="http://www.ab.com">www.ab.com</a>	
Certifications	CE marked for all applicable directives, cULus, and TUV

### 2.2 Operating Characteristics (at rated temperature range)

	Make, minimum	Break, maximum
Sensing distance horizontal plane of operation	10mm	25mm
Sensing distance vertical plane of operation	6mm	20mm
Typical misalignment	±4mm (see Misalignment Graphs)	
Operational Current	≤ 30mA + 1 Aux	
Maximum # of switches, connected in series	Monitoring Relay Unit dependent (see Section 10)	
Operating Voltage	24V dc +10% / -15% (see Section 9)	

### 2.3 Physical Characteristics

Case Material	ULTRADUR
Actuator Material	ULTRADUR
Colour	Red

### 2.4 Outputs

Safety Output (Solid State Relay)	2 x N.C. 50mA
Auxiliary	1 x PNP N.O. 200mA

### 2.5 Response Time

Switch response time	5ms
Series response time	5ms
Maximum Frequency of Operation	1Hz

### 2.6 Environmental

Operating Temperature	-10...+55°C (+14...+131°F)
Operating Humidity	5% -95% relative
Washdown rating / Enclosure type rating	NEMA 3, 4X, 12,13, IP67, 68 & 69K
Shock & Vibration	IEC680068-2-27 30 g, 11ms IEC680068-2-6 10...55Hz
E.M.C.	EN 61000-6-2, EN 60947-5-3

### 2.7 Protection

Safety Output Short-Circuit Protection	Provided by the approved safety Relays (See section 10)
Auxiliary Overload Protection	Internal Resettable Fuse
24V Supply Reverse Polarity Protection	Incorporated
Electrical Life	1 x 10 <sup>6</sup> cycles

## 4 Magnetically Coded Non Contact Switch Installation Instructions

### 3. Physical Dimensions - mm (inches)

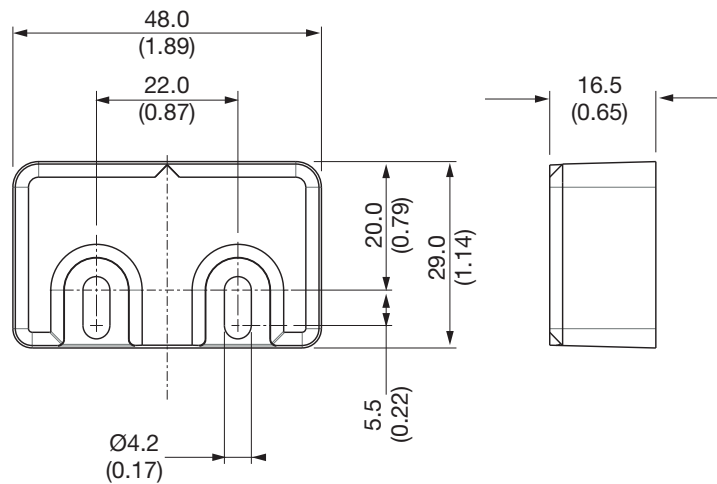
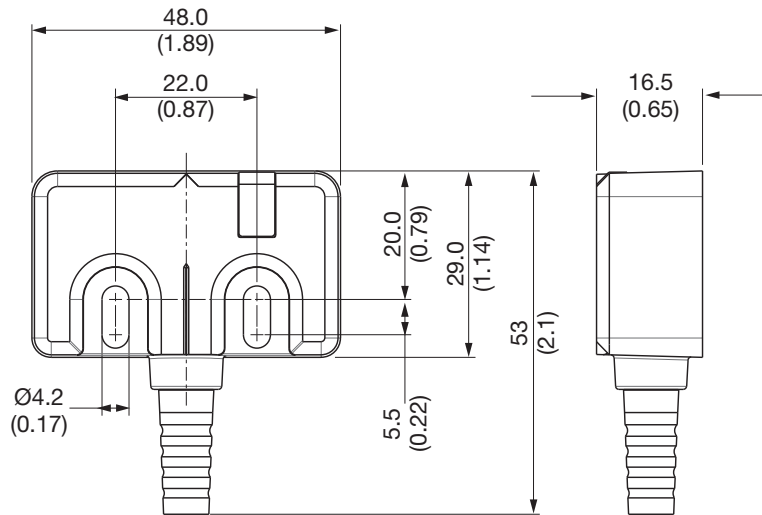

### 4. Mounting Information

Use non-removable screws, bolts, or nuts to mount the switch and actuator. Do not over torque the mounting hardware. It is recommended to use M3 screws and washers throughout.

Position the switch and actuator so they are aligned with each other.

#### 4.1 Mounting for Maximum Misalignment

Mount the Sensor to the fixed part of the guard and the Actuator to the movable section. Keep the Sensor and Actuator within the sensing range detailed in section 4.4.

**Note:** Refer to Technical Specifications for Certification information and ratings.

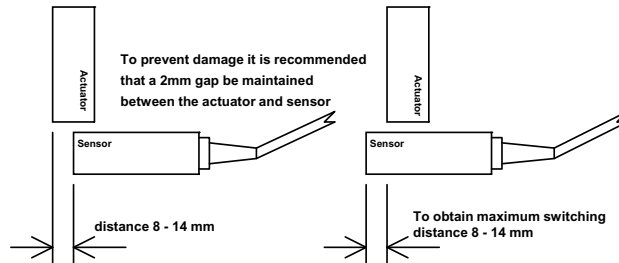
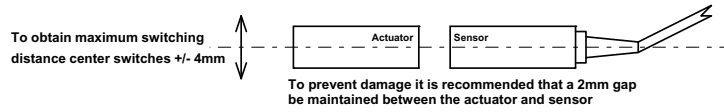

For more detailed misalignment characteristics refer to the misalignment curves

**4.2 Maximum Torque Specification** - 1 N•M (8.86 in•lbs), use non-magnetic fixing hardware.

**4.3 Minimum Distance Between Sensors** - 50mm

**4.4 Misalignment Curve**

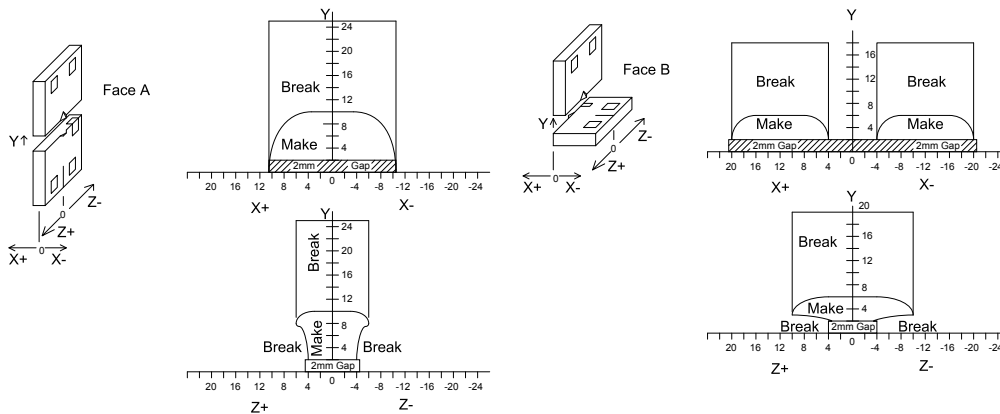

**Note:** To prevent damage to the MC2 it is recommended to leave a 2mm gap between the Sensor and Actuator. The maximum switching distance and misalignment tolerance will be obtained when the MC2 is mounted on non-ferrous material. Mounting the MC2 on ferrous/magnetic material will reduce the switching distances and tolerance to misalignment.

**4.5 Direction of Approach**

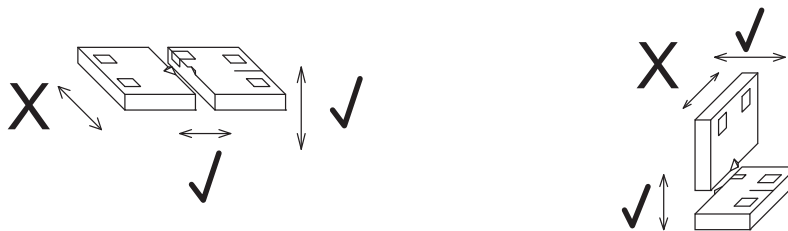

**Note:** Refer to Technical Specifications for Certification information and ratings.

## 6 Magnetically Coded Non Contact Switch Installation Instructions

### 5. LED Operation and Diagnostic

#### Unit Indicators (per IEC 60073)

Device Output LED	State	Status	Troubleshooting
	Off	Not Powered	Check supply, check wiring to controller A
	Off	Overload	Check AUX connections
	Red	Actuator not present	If actuator present check misalignment.
	Green	Actuator Present	NA
Green flashing	Actuation not present on other switches or wiring fault	Check wiring to controller Check actuators on other switches	

### 6. Troubleshooting

#### 6.1 Series Circuit - 2 Guards Open

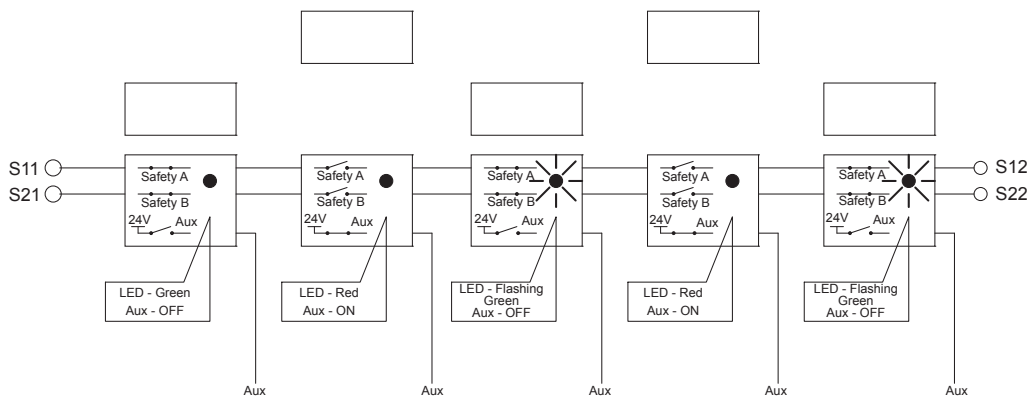

The auxiliary contacts close at the same time as the first safety contact opens

#### 6.2 Series Circuit - Open circuit on channel A

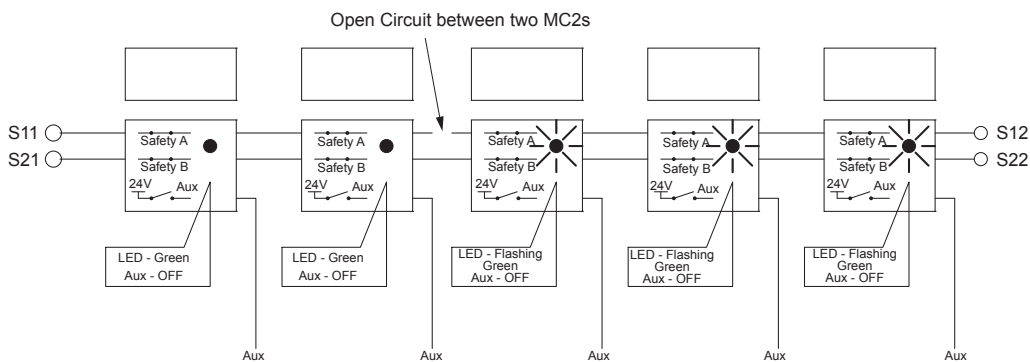

The auxiliary contacts close at the same time as the first safety contact opens

**Note:** Refer to Technical Specifications for Certification information and ratings.

## 7. Connection Information

### 7.1 Wiring Diagram

Pin #	Wire Colour	Signal
1	White	PNP Aux
2	Brown	+24V
3	Green	Not connected
4	Yellow	Safety B
5	Grey	Safety A
6	Pink	Safety B
7	Blue	0V
8	Red	Safety A

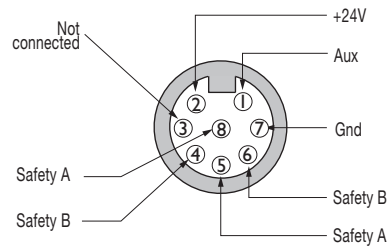

### 7.2 Recommended Mating Cable

For 8-Pin micro (M12) option. 889D-F8AB-\*. Lengths are available up to 30m (98.4 ft)

### 7.3 Connection Table

	MSR100 family	MSR200/300
Red/Safety A Grey/Safety A	S11 S12	S11 S12 or S42
Yellow/Safety B Pink/Safety B	S21 S22	S21 S22 or S52
Brown / +24V Blue / 0V	A1 / +24V A2 / 0V	A1 / +24V A2 / 0V

**Note:** When the MC2 is used with any MSR100 series Relay for the diagnostic function to operate correctly the Red and Grey wires (Safety A) must be connected to S11 and S12.

**Note:** Refer to Technical Specifications for Certification information and ratings.

## 8 Magnetically Coded Non Contact Switch Installation Instructions

### 8. Power Supply Requirements

24V dc +10%/-15% has to be supplied by a power supply that complies with IEC / EN 60204 and IEC / EN 61558-1. Such a power supply meets the electrical safety requirements and maintains the minimum power of 20.4V dc during 20ms even in the event of voltage dips.

When using an approved Relay with an MC2 and the same power supply is utilised for all devices the Relay will provide surge protection for the MC2. If a separate power supply is used for the MC2 then extra protection will be required.

### 9. Approved Monitoring Relay Units

1. **MC2 can only be used with the approved Relays, use of other devices not listed is at the users own risk.**
2. **Only 24Vdc MSR Relays or MSR Relays configured for 24Vdc operation are compatible with MC2.**

#### 9.1 Approved Monitoring Relay Unit List and maximum number of series MC2s

Monitoring Relay Series	Catalogue Part No.	Maximum number of MC2 units in series		
		24Vdc Supply Voltage		
		-5%	-10%	-15%
<i>MSR Series</i>				
MSR30RT/RTP	440R-N23197/440R-N23198	10	10	10
<i>MSR 100 Series</i>				
MSR121RT	440R-J23102	8	-	-
MSR123RT	440R-J23106	8	-	-
MSR124RT	440R-G23110/440R-G23108/440R-G23107	10	10	10
MSR126T/R	440R-N23117/440R-N23123	10	10	10
MSR126.1T/.1R	440R-N23114/440R-N23120	10	10	10
MSR127T/TP	440R-N23126/440R-N23132	10	10	10
MSR127R/RP	440R-N23129/440R-N23135	10	10	10
MSR131RTP	440R-C23139	10	10	10
MSR138DP	440R-M23151	10	10	10
MSR138.1DP	440R-M23084	10	10	10
MSR142RTP	440R-G23216	10	8	-
MSR144RTP	440R-C23205	10	10	10
MSR178DP	440R-M23227	10	10	10
<i>MSR 200 Series</i>				
MSR210P	440R-H23176	10	10	10
MSR220P	440R-H23177	10	10	10
<i>MSR300 Series</i>				
MSR320P connected to a MSR310 or MSR312	440R-W23218	10	10	10

**Note:** For up-to-date information, visit [www.ab.com](http://www.ab.com)

#### 9.2 Safety Ratings

1. An MC2 can achieve up to Cat 4/PLe, SIL CL3 when individually monitored by an approved Monitoring Relay Unit (see 9.1) that itself achieves Cat 4/PLe, SIL CL3.
2. Two or more MC2 Sensors connected in series with an approved Relay achieves up to CAT3/PLd/SIL CL2.

**Note:** Refer to Technical Specifications for Certification information and ratings.



## 10. Application Wiring Examples

### 10.1 Single Switch, Automatic Reset, Monitored Outputs MSR127TP

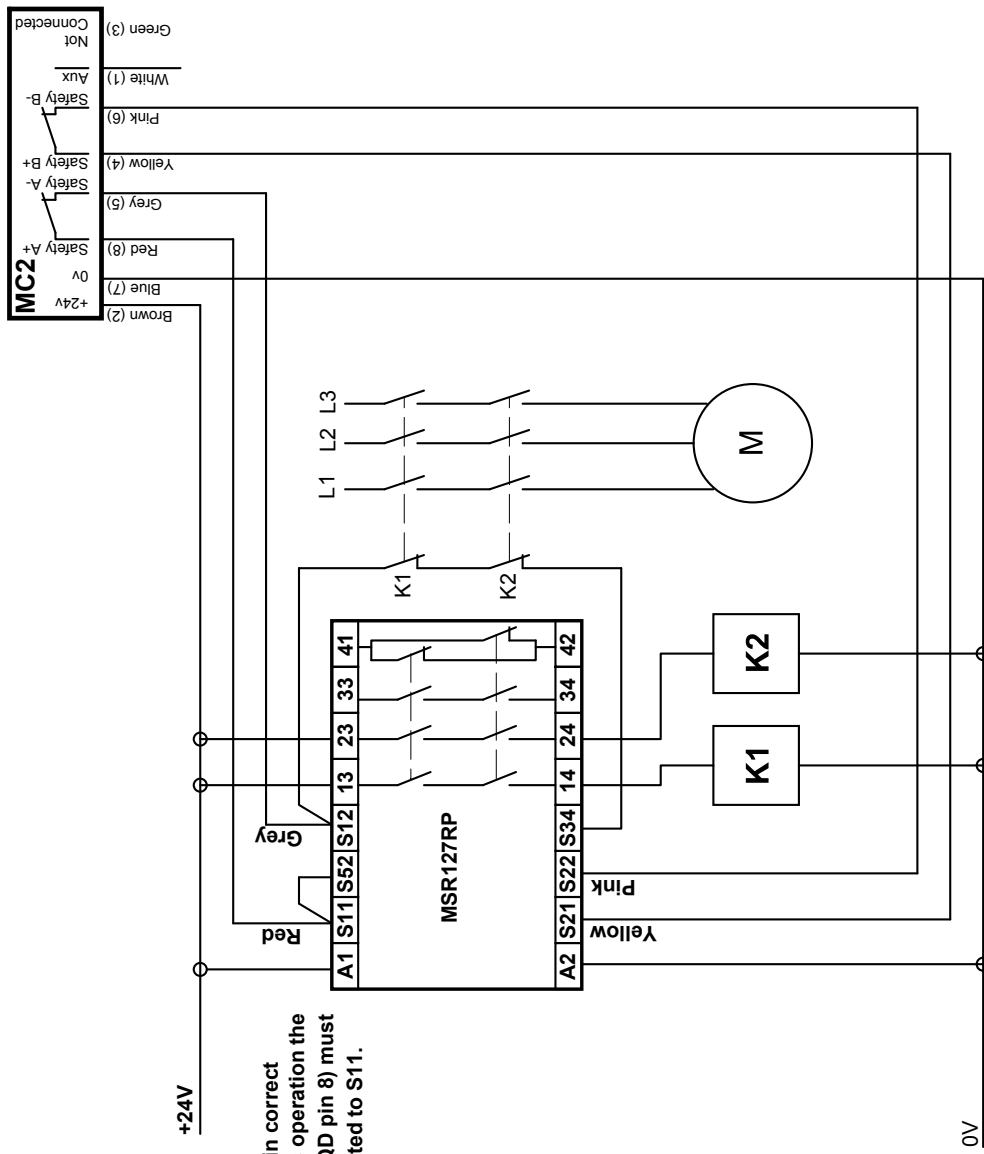

**Note:** Refer to Technical Specifications for Certification information and ratings.

# 10 Magnetically Coded Non Contact Switch Installation Instructions

## 10.2 Multiple Switches, Automatic Reset, Monitored Output MSR127TP

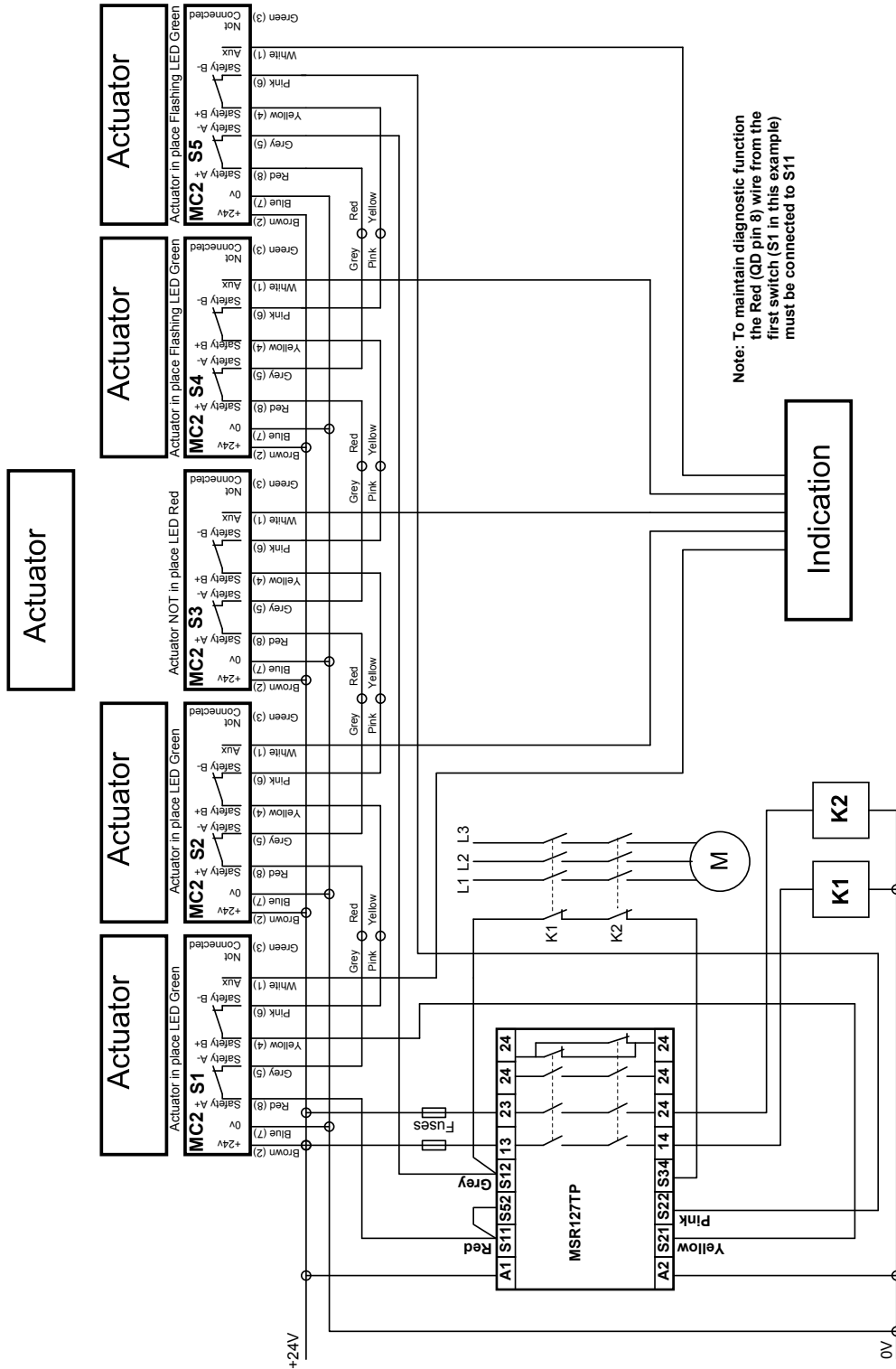

10.3 Multiple Switches, Manual Reset, Monitored Output MSR210P

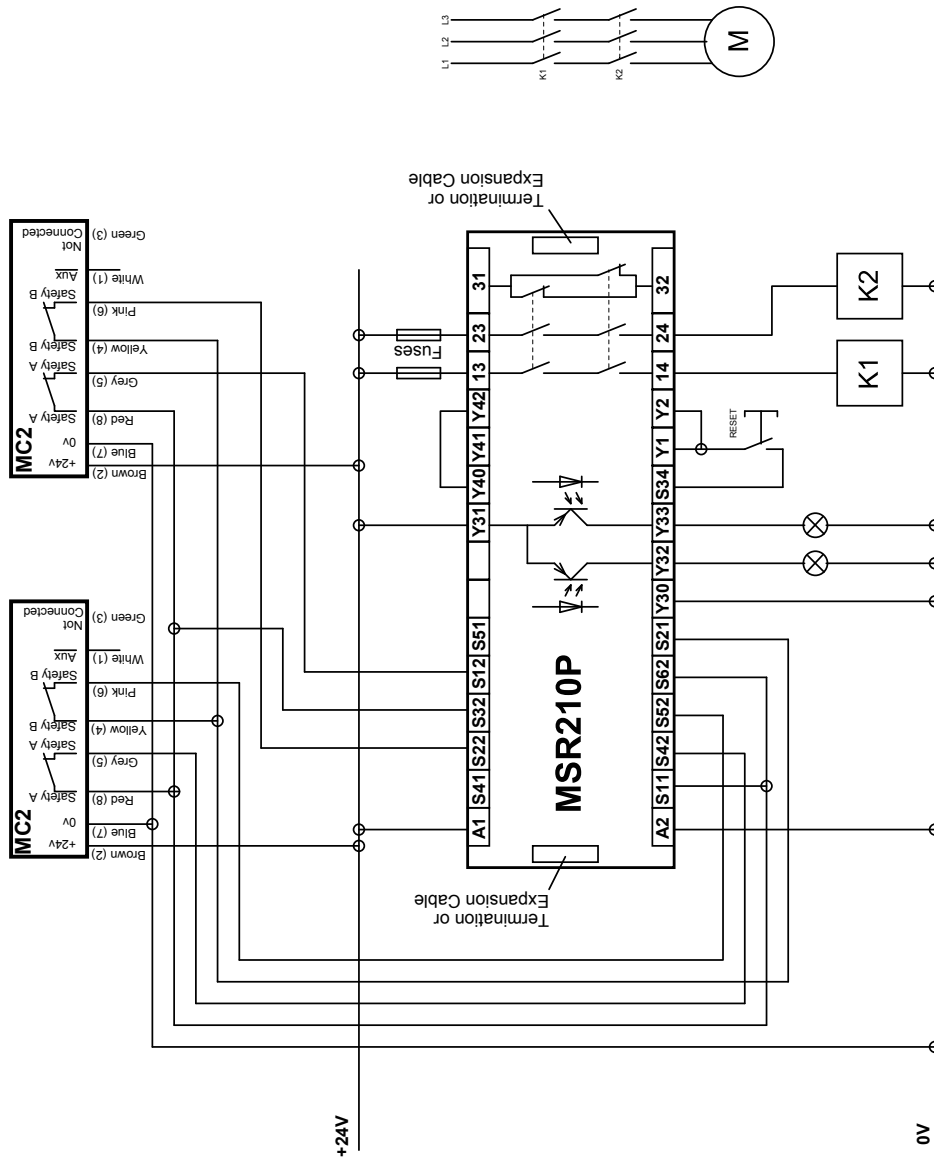

## 12 Magnetically Coded Non Contact Switch Installation Instructions

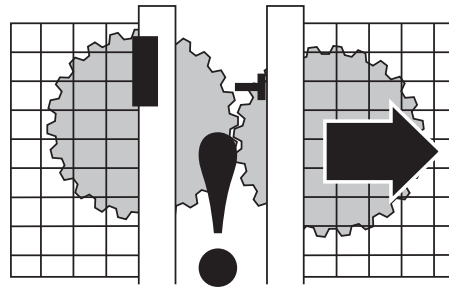

Check the machine is isolated and stopped whenever the interlocked guard door is open.

**IMPORTANT:** After installation and commissioning, the actuator, switch and hardware should be coated with tamper evident varnish or similar compound.

## 11. Maintenance

### Every six months

Check the correct operation of the switching circuit. Also check for signs of abuse or tampering. Inspect the switch casing for damage.

## 12. Repair

If there is any malfunction or damage, no attempts at repair should be made. The unit should be replaced before machine operation is allowed.



## 13. Declaration of Conformity

This is to declare that the products shown on this document conforms with the Essential Health and Safety Requirements (EHSRs) of the European Machinery Directive (98/37/EC Machinery Directive, 2004/108/EC EMC Directive). These products also conform to EN 60947-5-3, EN 1088, EN ISO 12100 parts 1 & 2, EN 60204-1 and have Third Party Approval.

For a comprehensive certificate please visit: [www.ab.com](http://www.ab.com)



**Allen-Bradley**

Guardmaster®