

Description

The SPX5205 is a positive voltage regulator with very low dropout voltage, output noise and ground current (750 μ A at 100mA). V_{OUT} has a tolerance of less than 1% and is temperature compensated. Fixed output voltages 1.8V, 3.0V, 3.3V, and 5.0V and an adjustable version are available in a small 5-pin SOT-23 package. Other key features include zero off-mode current, reverse battery protection, thermal shutdown and current limit. The SPX5205 is an excellent choice for use in battery powered applications, and where power conservation is desired such as: cellular/ cordless telephones, radio control systems and portable computers.

TopView

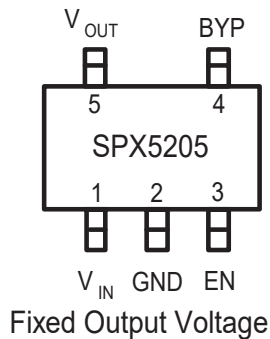

TopView

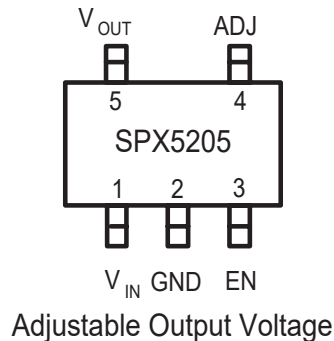

FEATURES

- Low Noise Output LDO: 40 μ VRMS Possible
- 1% Initial Accuracy
- Very Low Quiescent Current: 70 μ A
- Low Dropout Voltage (210mV at 150mA)
- Current and Thermal Limiting
- Reverse-Battery Protection
- Wide Range of Fixed Output Voltages: 1.8V, 3.0V, 3.3V and 5.0V
- Zero Off-Mode Current
- Small 5-Pin SOT-23
- Pin Compatible to MIC5205/MAX8877 (fixed options only) and LP2985

APPLICATIONS

- PDA
- Battery Powered Systems
- Cellular Phone
- Cordless Telephones
- Radio Control Systems
- Laptop, Palmtop and Notebook Computers
- Portable Consumer Equipment
- Portable Instrumentation
- Bar Code Scanners
- SMPS Post-Regulator

Ordering Information - [Back Page](#)

Typical Applications Circuit

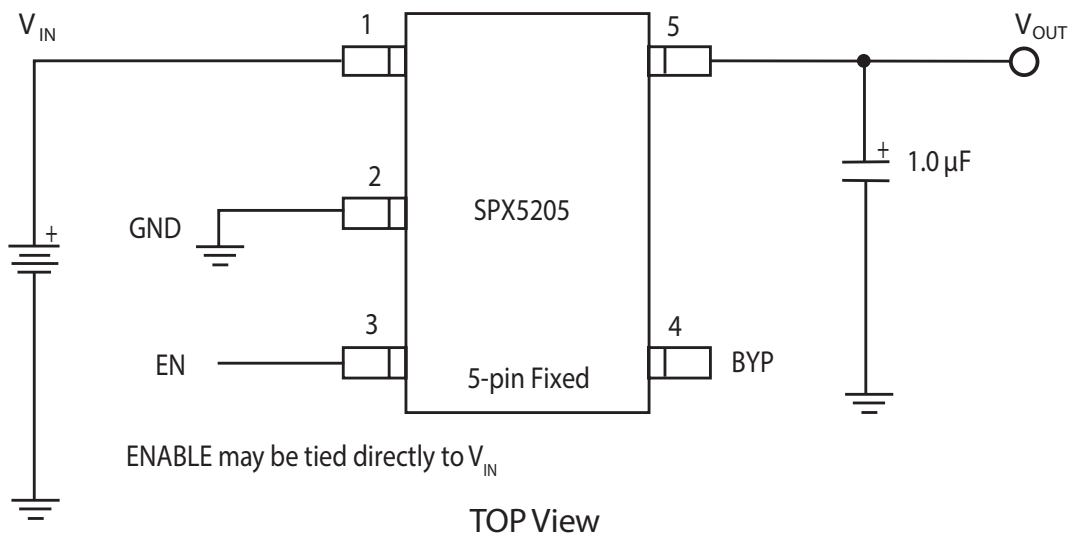

Absolute Maximum Ratings

These are stress ratings only and functional operation of the device at these ratings or any other above those indicated in the operation sections of the specifications below is not implied. Exposure to absolute maximum rating conditions for extended periods of time may affect reliability.

Thermal Shutdown	Internally limited
Lead Temperature (Soldering, 5 seconds)	260°C
Input Supply Voltage	-20V to +20V
Enable Input Voltage	-20V to +20V

Recommended Operating Conditions

Input Supply Voltage	+2.5V to +16V
Operating Junction Temperature Range	-40°C to +125°C
Enable Input Voltage	0V to V_{IN}
SOT-23-5 (θ_{JA})	See Note 1

Electrical Characteristics

$T_J = 25^\circ\text{C}$, $V_{IN} = V_{OUT} + 1\text{V}$, $I_L = 100\mu\text{A}$, $C_L = 1\mu\text{F}$, and $V_{ENABLE} \geq 2.4\text{V}$. The “•” denotes the specifications which apply over full junction temperature range -40°C to $+125^\circ\text{C}$, unless otherwise specified.

PARAMETER	MIN.	TYP.	MAX.	UNITS	•	CONDITIONS
Output voltage tolerance (V_{OUT})	-1		+1	% V_{NOM}		
	-2		+2		•	
Output voltage temperature coefficient		57		ppm/°C	•	
Line regulation		0.03	0.1	%V		$V_{IN} = V_{OUT} + 1$ to 16V and $V_{EN} \leq 6\text{V}$
			0.2		•	$V_{IN} = V_{EN} = V_{OUT} + 1 \leq 8\text{V}$
			0.2			$V_{IN} = V_{EN} = V_{OUT} + 1$ to 16V $T_A = 25^\circ\text{C}$ to 85°C
Load regulation		0.1	0.2	%		$V_{IN} = V_{OUT} + 1 \geq 2.5\text{V}$
			0.5		•	$I_L = 1\text{mA}$ to 150mA
			1.0		•	$I_L = 100\mu\text{A}$ to 1mA
Dropout voltage ⁽²⁾ ($V_{IN} - V_O$)		30	50	mV		$I_L = 100\mu\text{A}$
			70		•	
		140	190	mV		$I_L = 50\text{mA}$
			230		•	
		180	250	mV		$I_L = 100\text{mA}$
			300		•	
		210	275	mV		$I_L = 150\text{mA}$
		350		•		
Quiescent current (I_{GND})		0.05	1	μA		$V_{ENABLE} \leq 0.4\text{V}$
			5		•	$V_{ENABLE} \leq 0.25\text{V}$
Ground pin current (I_{GND})		70	125	μA		$I_L = 100\mu\text{A}$
			150		•	
		350	600	μA		$I_L = 50\text{mA}$
			800		•	
		750	1000	μA		$I_L = 100\text{mA}$
			1500		•	
		1300	1900	μA		$I_L = 150\text{mA}$
		2500	•			

Electrical Characteristics (Continued)

$T_J = 25^\circ\text{C}$, $V_{IN} = V_{OUT} + 1\text{V}$, $I_L = 100\mu\text{A}$, $C_L = 1\mu\text{F}$, and $V_{ENABLE} \geq 2.4\text{V}$. The “*” denotes the specifications which apply over full junction temperature range -40°C to $+125^\circ\text{C}$, unless otherwise specified.

PARAMETER	MIN.	TYP.	MAX.	UNITS	•	CONDITIONS
Ripple rejection		70		dB		
Current limit (I_{LIMIT})		360	500	mA		$V_{OUT} = 0\text{V}$
Output noise (e_{NO})		300		μV_{RMS}		$I_L = 10\text{mA}$, $C_L = 1\mu\text{F}$, $C_{IN} = 1\mu\text{F}$ (10Hz - 100kHz)
		40				$I_L = 10\text{mA}$, $C_L = 10\mu\text{F}$, $C_{BYP} = 1\mu\text{F}$, $C_{IN} = 1\mu\text{F}$ (10Hz - 100kHz)
Input voltage level logic low (V_{IL})			0.4	V		OFF
Input voltage level logic high (V_{IH})	2.0			V		ON
Enable input current		0.01	2	μA		$V_{IL} \leq 0.4\text{V}$
		3	20			$V_{IH} \geq 2.0\text{V}$

NOTE:

- The maximum allowable power dissipation is a function of maximum operating junction temperature, $T_{J(max)}$, the junction to ambient thermal resistance, and the ambient θ_{JA} , and the ambient temperature T_A . The maximum allowable power dissipation at any ambient temperature is given: $P_{D(max)} = (T_{J(max)} - T_A) / \theta_{JA}$, exceeding the maximum allowable power limit will result in excessive die temperature; thus, the regulator will go into thermal shutdown. The θ_{JA} of the SPX5205 is 220°C/W mounted on a PC board.
- Not applicable to output voltages of less than 2V.

Typical Performance Characteristics

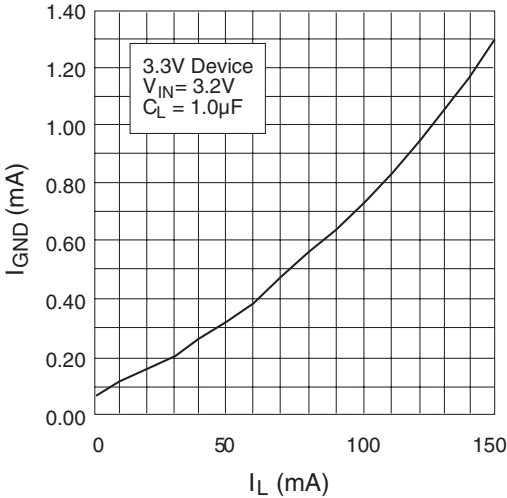

Figure 1. Ground Current vs. Load Current

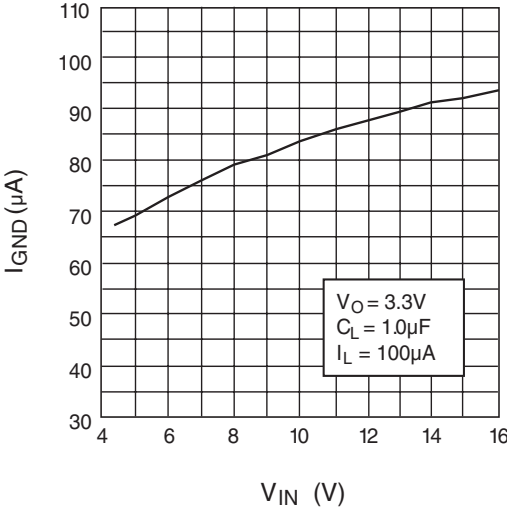

Figure 2. Ground Current vs. Input Voltage

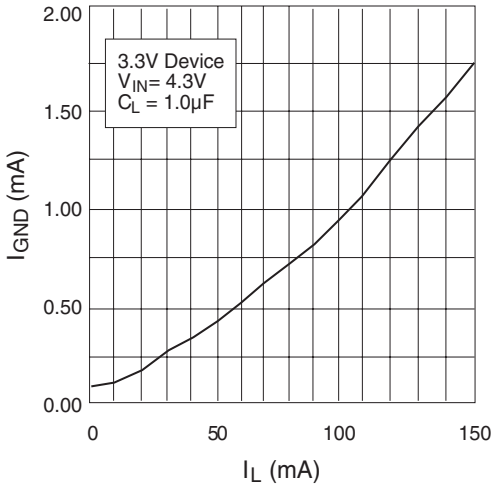

Figure 3. Ground Current vs. Load Current in Dropout

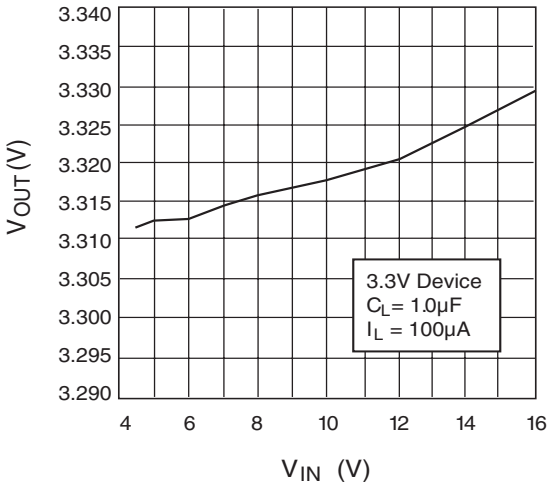

Figure 4. Output Voltage vs. Input Voltage

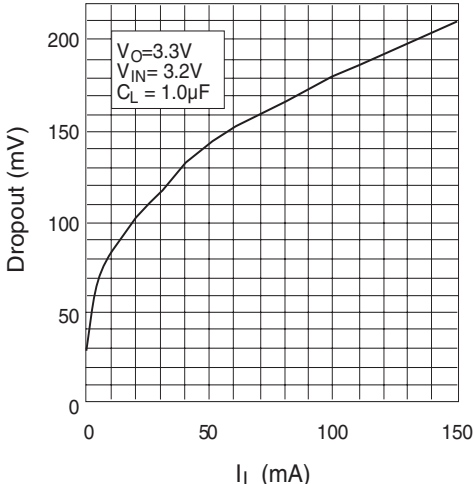

Figure 5. Dropout Voltage vs. Load Current

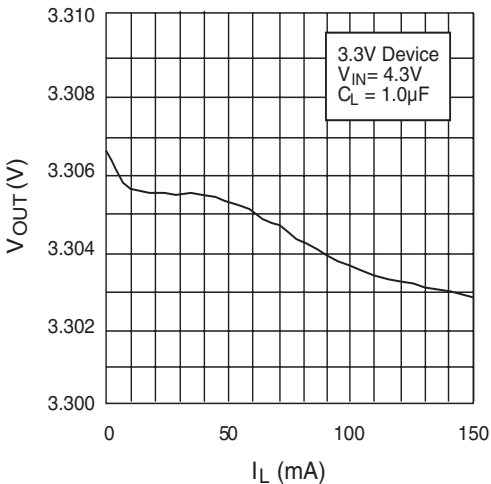

Figure 6. Output Voltage vs. Load Current

Typical Performance Characteristics (Continued)

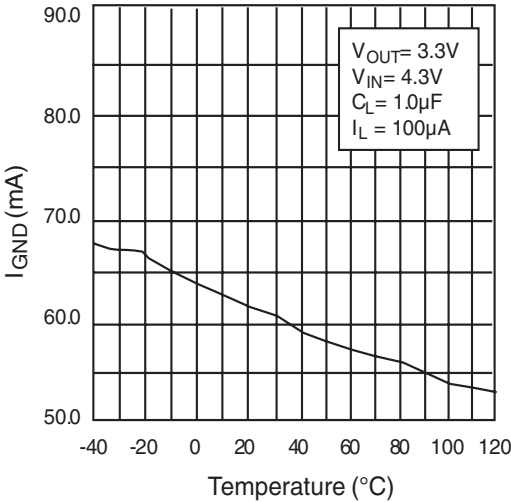

Figure 7. Ground Current vs. Temperature at I_{LOAD} = 100µA

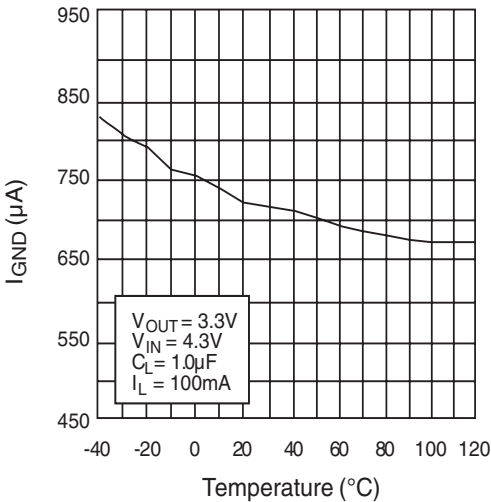

Figure 8. Ground Current vs. Temperature at I_{LOAD} = 100mA

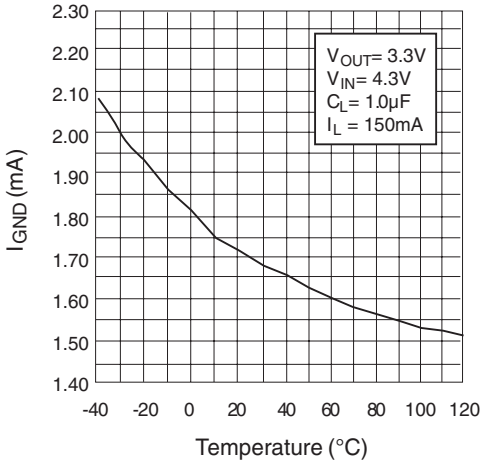

Figure 9. Ground Current in Dropout vs. Temperature

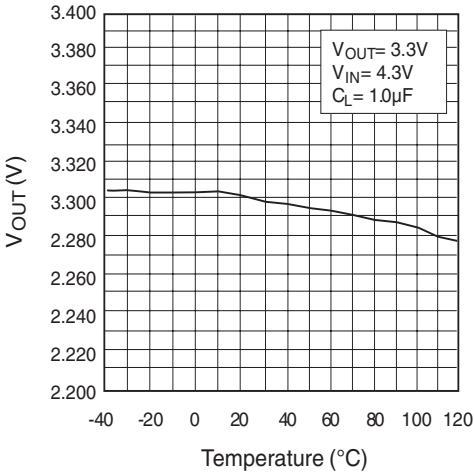

Figure 10. Output Voltage vs. Temperature

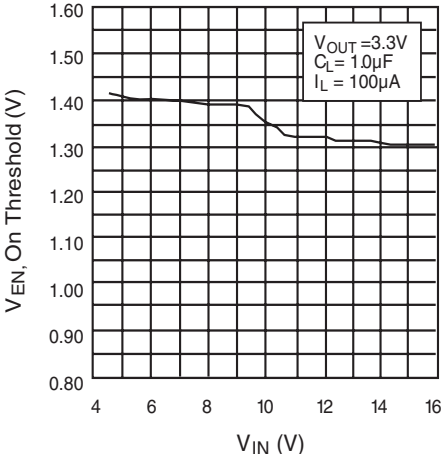

Figure 11. ENABLE Voltage, ON Threshold vs. Input Voltage

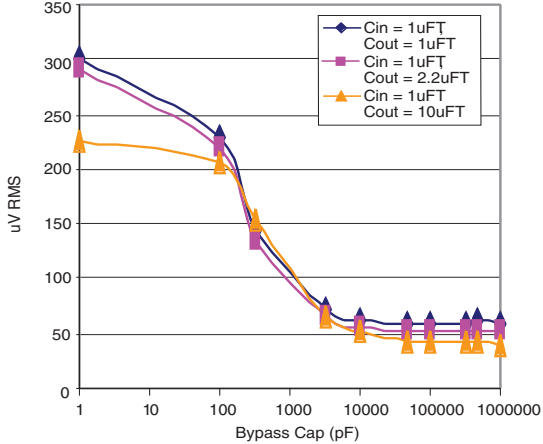

Figure 12. Output Noise vs. Bypass Capacitor Value

Application Information

The SPX5205 requires an output capacitor for device stability. Its value depends upon the application circuit. In general, linear regulator stability decreases with higher output currents. In applications where the SPX5205 is putting out less current, a lower output capacitance may be sufficient. For example, a regulator sourcing only 10mA, requires approximately half the capacitance as the same regulator sourcing 150mA.

Bench testing is the best method for determining the proper type and value of the capacitor since the high frequency characteristics of electrolytic capacitors vary widely, depending on type and manufacturer. A high quality 2.2 μ F aluminum electrolytic capacitor works in most application circuits, but the same stability often can be obtained with a 1 μ F tantalum electrolytic.

With the SPX5205 adjustable version, the minimum value of output capacitance is a function of the output voltage. The value decreases with higher output voltages, since closed loop gain is increased.

Typical Applications Circuits

A 10nF capacitor on the BYP pin will significantly reduce output noise but it may be left unconnected if the output noise is not a major concern. The SPX5205 start-up speed is inversely proportional to the size of the BYP capacitor. Applications requiring a slow ramp-up of the output voltage should use a larger C_{BYP} . However, if a rapid turn-on is necessary, the BYP capacitor can be omitted.

The SPX5205's internal reference is available through the BYP pin.

The Typical Application Circuit shown on page 1 represents a SPX5205 standard application circuit. The EN (enable) pin is pulled high (>2.0V) to enable the regulator. To disable the regulator, $EN < 0.4V$.

The SPX5205 in Figure 13 illustrates a typical adjustable output voltage configuration. Two resistors (R1 and R2) set the output voltage. The output voltage is calculated using the formula:

$$V_{OUT} = 1.235V \times (1 + R1/R2)$$

R2 must be >10 k Ω , and for best results, R2 should be between 22 k Ω and 47k Ω .

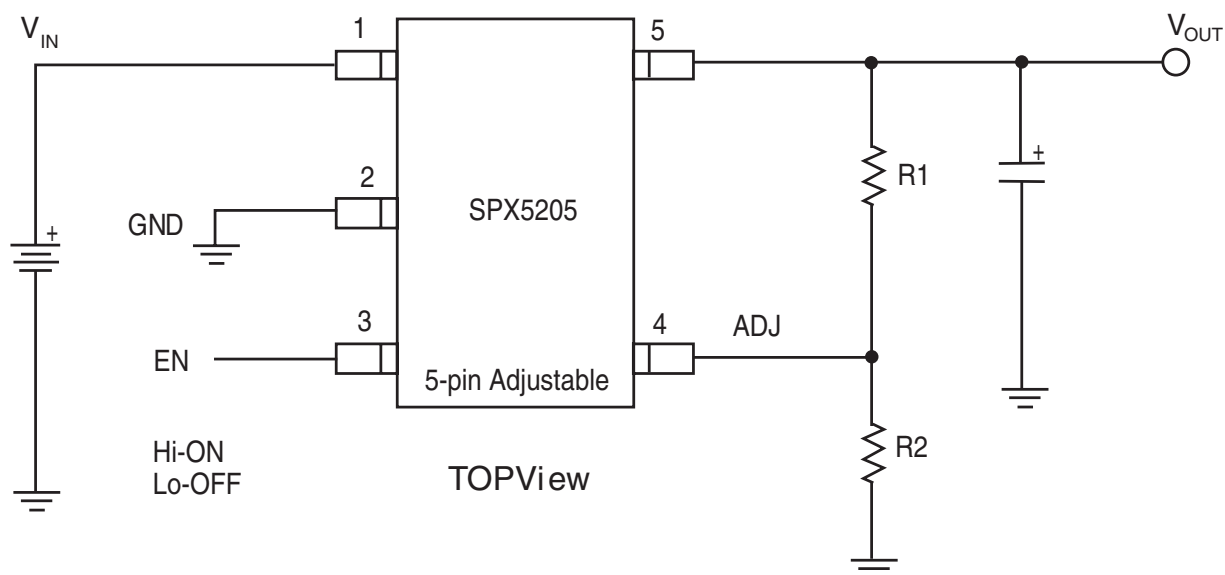
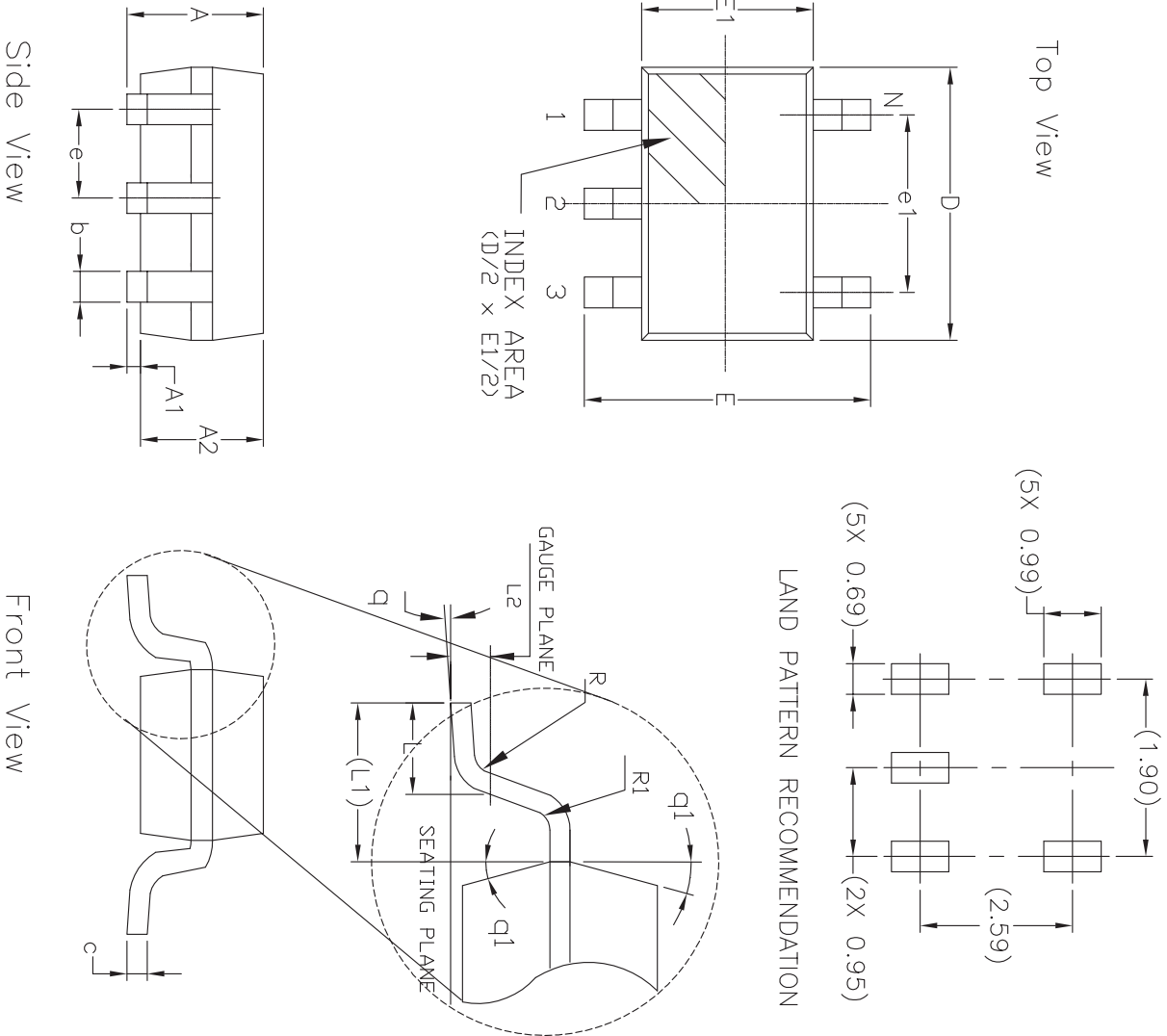

Figure 13. Typical Adjustable Output Voltage

Mechanical Dimensions

SOT-23-5



5 Pin SOT-23 JEDEC MO-178 Variation AA

SYMBOLS	DIMENSIONS IN MM (Control Unit)			DIMENSIONS IN INCH (Reference Unit)		
	MIN	NOM	MAX	MIN	NOM	MAX
A	—	—	1.45	—	—	0.057
A1	0.00	—	0.15	0.000	—	0.006
A2	0.90	1.15	1.30	0.036	0.045	0.051
b	0.30	—	0.50	0.012	—	0.020
c	0.08	—	0.22	0.003	—	0.009
D	—	2.90 BSC	—	—	0.115 BSC	—
E	—	2.80 BSC	—	—	0.111 BSC	—
E1	—	1.60 BSC	—	—	0.063 BSC	—
e	—	0.95 BSC	—	—	0.038 BSC	—
e1	—	1.90 BSC	—	—	0.075 BSC	—
L	0.30	0.45	0.60	0.012	0.018	0.024
L1	—	0.60 REF	—	—	0.024 REF	—
L2	—	0.25 BSC	—	—	0.010 BSC	—
R	0.10	—	—	0.004	—	—
R1	0.10	—	0.25	0.004	—	0.010
q	0°	4°	8°	0°	4°	8°
q1	5°	10°	15°	5°	10°	15°
N	—	5	—	—	5	—

Drawing No: PDD-00000025
 Revision: B

Ordering Information⁽¹⁾

Part Number	Operating Temperature Range	Lead-Free	Package	Packaging Method	Accuracy	Output Voltage
SPX5205M5-L/TR	-40°C ≤ T _J ≤ 125°C	Yes ⁽²⁾	5-pin SOT-23	Tape and Reel	1%	Adjustable
SPX5205M5-L-1-8/TR						1.8V
SPX5205M5-L-3-0/TR						3.0V
SPX5205M5-L-3-3/TR						3.3V
SPX5205M5-L-5-0/TR						5.0V

NOTE:

1. Refer to www.exar.com/SPX5205 for most up-to-date Ordering Information.
2. Visit www.exar.com for additional information on Environmental Rating.

Revision History

Revision	Date	Description
K	--	Sipex / Exar legacy datasheet
L	8/31/18	Update to MaxLinear logo. Update format and Ordering Information. Added Figure numbers. Corrected C _L unit in Figure 11. Updated Typical Application Circuit on page 1 and Figure 13 to differentiate between fixed and adjustable versions. Updated last paragraph of Typical Applications Circuits section. Updated temperature at top of Electrical Characteristics.



Corporate Headquarters:
 5966 La Place Court
 Suite 100
 Carlsbad, CA 92008
 Tel.: +1 (760) 692-0711
 Fax: +1 (760) 444-8598
www.maxlinear.com

High Performance Analog:
 1060 Rincon Circle
 San Jose, CA 95131
 Tel.: +1 (669) 265-6100
 Fax: +1 (669) 265-6101
www.exar.com

The content of this document is furnished for informational use only, is subject to change without notice, and should not be construed as a commitment by MaxLinear, Inc.. MaxLinear, Inc. assumes no responsibility or liability for any errors or inaccuracies that may appear in the informational content contained in this guide. Complying with all applicable copyright laws is the responsibility of the user. Without limiting the rights under copyright, no part of this document may be reproduced into, stored in, or introduced into a retrieval system, or transmitted in any form or by any means (electronic, mechanical, photocopying, recording, or otherwise), or for any purpose, without the express written permission of MaxLinear, Inc.

MaxLinear, Inc. does not recommend the use of any of its products in life support applications where the failure or malfunction of the product can reasonably be expected to cause failure of the life support system or to significantly affect its safety or effectiveness. Products are not authorized for use in such applications unless MaxLinear, Inc. receives, in writing, assurances to its satisfaction that: (a) the risk of injury or damage has been minimized; (b) the user assumes all such risks; (c) potential liability of MaxLinear, Inc. is adequately protected under the circumstances.

MaxLinear, Inc. may have patents, patent applications, trademarks, copyrights, or other intellectual property rights covering subject matter in this document. Except as expressly provided in any written license agreement from MaxLinear, Inc., the furnishing of this document does not give you any license to these patents, trademarks, copyrights, or other intellectual property.

Company and product names may be registered trademarks or trademarks of the respective owners with which they are associated.

© 2001 - 2018 MaxLinear, Inc. All rights reserved

Mouser Electronics

Authorized Distributor

Click to View Pricing, Inventory, Delivery & Lifecycle Information:

MaxLinear:

[SPX5205M5-L](#) [SPX5205M5-L-3-3](#) [SPX5205M5-L/TR](#) [SPX5205M5-L-5-0/TR](#) [SPX5205M5-L-3-3/TR](#) [SPX5205M5-L-1-2/TR](#) [SPX5205M5-L-3-0/TR](#) [SPX5205M5-L-1-8/TR](#) [SPX5205M5-L-2-5/TR](#) [SPX5205M5-L-1-2](#) [SPX5205M5-L-1-8](#) [SPX5205M5-L-2-5](#) [SPX5205M5-L-3-0](#) [SPX5205M5-L-5-0](#)