

**RoHS  
Compliant  
Drawing For  
Reference Only**

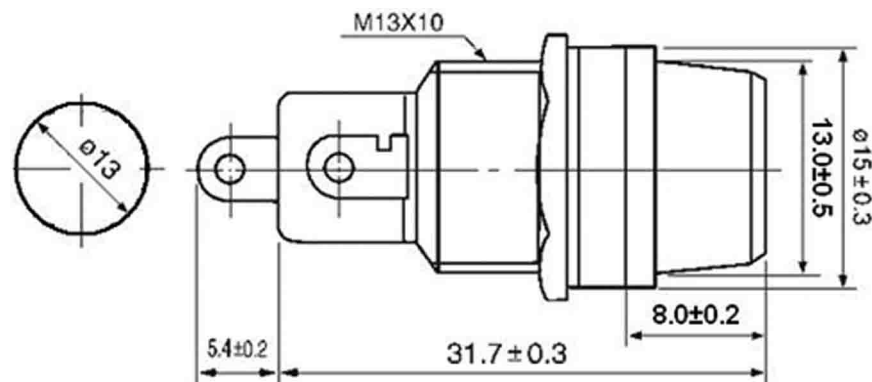

★SPECIFICATIONS:

STRUCTURE:

Holder: bakelite  
Clip pole: silver-plating brass  
or nickel-plating brass

★ELECTRONIC CHARACTER:

Rating current: 10A  
Rating voltage: 250V/125AC

★PACKING:

200PCS/BAG  
3000PCS/CTN

Technical requirement :

1. This product should meet EU RoHS related requirement.
2. The surface of plastic part should be without any crackle such as burr,lack,and so on phenomenon.
3. The surface of metal part should be without any defect such as scour,nick,oxidation and plating problem.
4. The electronic performance should be the same as spec.

**DCI DRAGON CITY INDUSTRIES LIMITED**

Design			K.W Law	Remark		Scale	
Drawing			W.K Yeung	Remark		Material	
Item Name	FUSE HOLDER FOR 5 X 20MM	Tolerance :	Check	K.L Wong	Remark	Drawing No.	B103191126
Item No.	FH-301S-EN-HZ	Unit : mm	Approval	K.W Chan	Remark	Sheet	