

WIRE SIZE #22-#26  
SECTION E-E

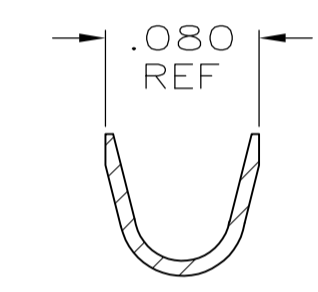

INSULATION RANGE .061 MAX  
SECTION G-G

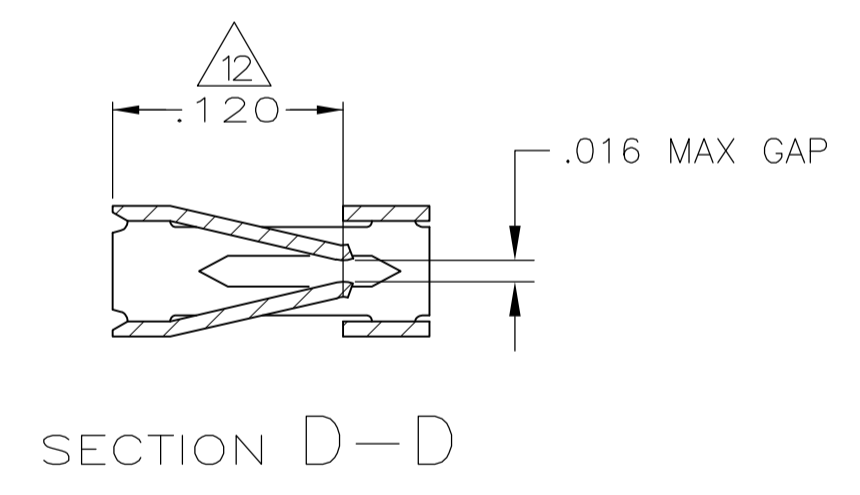

SECTION D-D

1. REELED FOR MINI-APPLICATOR.
2. GOLD FLASH OVER NICKEL, .000015 GOLD ON CONTACT AREA.
3. GOLD FLASH OVER NICKEL, .000030 GOLD ON CONTACT AREA.
4. PREPLATED 0.00127-0.00381 (.000050-.000150) BRIGHT TIN.
5. .000050 NICKEL ON ENTIRE CONTACT, .000015 GOLD IN CONTACT AREA.
6. GOLD PLATING NOT REQUIRED IN THIS AREA.
7. SHEARED EDGES PERMITTED TO BE UNPLATED.
8. .000050 NICKEL ENTIRE CONTACT, .000015 GOLD ON CONTACT AREA, .000100-.000200 BRIGHT TIN LEAD IN AREA K.
9. GOLD FLASH OVER NICKEL, .000050 GOLD ON CONTACT AREA.
10. CUT OUTS ON BOX AT MANUFACTURER'S OPTION.
11. .000030 GOLD IN CONTACT AREA, .000100-.000200 BRIGHT TIN-LEAD IN AREA K, ALL OVER .000050 NICKEL.
12. POINT OF MEASUREMENT FOR PLATING THICKNESS (INSIDE BEAMS).
13. .00030 GOLD IN CONTACT AREA, .000100-.000200 TIN IN AREA K, ALL OVER .000050 NICKEL.
14. .000050 NICKEL ENTIRE CONTACT, .000015 GOLD ON CONTACT AREA, .000100-.000200 TIN IN AREA K.

LOOSE PIECE	REF	6-87756-8
REELED	REF	6-87756-7
LOOSE PIECE	REF	6-87756-6
REELED	REF	6-87756-2
LOOSE PIECE	REF	1-87756-8
REELED	REF	1-87756-7
LOOSE PIECE	REF	1-87756-6
OBSOLETE	REF	1-87756-4
REELED	REF	1-87756-2
REELED	REF	1-87756-1
OBSOLETE	REF	1-87756-0
LOOSE PIECE	REF	87756-7
REELED	REF	87756-6
LOOSE PIECE	REF	87756-5
REELED	REF	87756-4
LOOSE PIECE	REF	87756-3
REELED	REF	87756-2
DESCRIPTION	FINISH	PART NUMBER

THIS DRAWING IS A CONTROLLED DOCUMENT.

DIMENSIONS: INCHES	TOLERANCES UNLESS OTHERWISE SPECIFIED:	DWN L.D.RINGLEY 12-10-85	TE Connectivity
0. PLC ± -	1. PLC ± -	CHK J. GESFORD 12-16-85	
	2. PLC ± -	APVD J. GESFORD 12-18-85	NAME
	3. PLC ± .005		PRODUCT SPEC
	4. PLC ± -		108-25,020
	ANGLES ± -		APPLICATION SPEC
	SEE TABLE		114-25,003
MATERIAL .008 THK CU-SN-P ALLOY 521	FINISH SEE TABLE	WEIGHT	SIZE CAGE CODE DRAWING NO
			A1 00779C=87756
		CUSTOMER DRAWING	RESTRICTED TO
			SCALE 10:1 SHEET 1 OF 1 REV T1