

# deTec2 Core

Safety light curtain

**SICK**  
Sensor Intelligence.



---

**Described product** deTec2 Core

**Manufacturer** SICK AG  
Erwin-Sick-Str. 1  
79183 Waldkirch, Germany  
Germany

**Legal information** This work is protected by copyright. Any rights derived from the copyright shall be reserved for SICK AG. Reproduction of this document or parts of this document is only permissible within the limits of the legal determination of Copyright Law. Any modification, expurgation or translation of this document is prohibited without the express written permission of SICK AG.

The trademarks stated in this document are the property of their respective owner.

© SICK AG. All rights reserved.

**Original document** This document is an original document of SICK AG.



## Contents

<b>1</b>	<b>About this document.....</b>	<b>6</b>
1.1	Scope.....	6
1.2	Target groups and structure of these operating instructions.....	6
1.3	Further information.....	7
1.4	Symbols and document conventions.....	7
<b>2</b>	<b>Safety information.....</b>	<b>8</b>
2.1	General safety notes.....	8
2.2	Correct use.....	8
2.3	Requirements for the qualification of personnel.....	9
<b>3</b>	<b>Product description.....</b>	<b>10</b>
3.1	Structure and function.....	10
3.2	Product characteristics.....	11
3.2.1	Absence of blind zones.....	11
3.2.2	Automatic calibration of the protective field width.....	11
3.2.3	Status indicators.....	11
3.3	Example applications.....	13
<b>4</b>	<b>Project planning.....</b>	<b>15</b>
4.1	Manufacturer of the machine.....	15
4.2	Operator of the machine.....	15
4.3	Design.....	15
4.3.1	Scanning range and protective field width.....	16
4.3.2	Minimum distance from the hazardous point.....	16
4.3.3	Minimum distance to reflective surfaces.....	18
4.3.4	Protection against interference from systems in close proximity to each other.....	20
4.4	Integration in electrical control.....	20
4.4.1	Restart interlock and external device monitoring.....	22
<b>5</b>	<b>Mounting.....</b>	<b>24</b>
5.1	Safety.....	24
5.2	Unpacking.....	24
5.3	Installation.....	24
5.3.1	Mount the QuickFix bracket.....	26
5.3.2	Mount optional FlexFix bracket.....	27
5.3.3	Mount optional replacement bracket.....	30
5.4	Attach information label.....	32
<b>6</b>	<b>Electrical installation.....</b>	<b>33</b>
6.1	Safety.....	33
6.2	Device connection (M12, 5-pin).....	34
6.3	Device connection via connection cable (M12, 5-pin to 8-pin).....	34

<b>7</b>	<b>Initial commissioning.....</b>	<b>35</b>
7.1	Safety.....	35
7.2	Switching on.....	35
7.3	Align the sender and receiver.....	36
7.4	Checks.....	38
<b>8</b>	<b>Operation.....</b>	<b>39</b>
8.1	Safety.....	39
8.2	Daily check.....	39
<b>9</b>	<b>Maintenance.....</b>	<b>42</b>
9.1	Safety.....	42
9.2	Regular cleaning.....	42
9.3	Regular inspection.....	43
<b>10</b>	<b>Troubleshooting.....</b>	<b>44</b>
10.1	Safety.....	44
10.2	Fault indicators.....	44
<b>11</b>	<b>Decommissioning.....</b>	<b>46</b>
11.1	Protection of the environment.....	46
11.2	Disposal.....	46
<b>12</b>	<b>Technical data.....</b>	<b>47</b>
12.1	Data sheet.....	47
12.2	Response time.....	49
12.3	power consumption.....	50
12.4	Table of weights.....	50
12.5	Dimensional drawings.....	51
<b>13</b>	<b>Ordering information.....</b>	<b>52</b>
13.1	Scope of delivery.....	52
13.2	Ordering information .....	52
<b>14</b>	<b>Accessories.....</b>	<b>53</b>
14.1	Ordering information, accessories.....	53
14.2	Weld spark guard.....	55
14.3	Deflector mirror.....	56
14.3.1	Mounting.....	57
14.3.2	Change in scanning range using deflector mirrors.....	57
14.3.3	Deflector mirror PNS75 - ordering information.....	57
14.3.4	Deflector mirror PSN125 - ordering information.....	58
14.4	Columns.....	58
14.5	Test rods.....	59
<b>15</b>	<b>List of figures.....</b>	<b>60</b>

---

<b>16</b>	<b>List of tables.....</b>	<b>61</b>
<b>17</b>	<b>Appendix.....</b>	<b>62</b>
17.1	Compliance with EC directives.....	62
17.2	Checklist for initial commissioning and commissioning.....	64

## 1 About this document

These operating instructions contain information required during the life cycle of the safety light curtain.

These operating instructions are available to all those who work with the safety light curtain.

Please read these operating instructions carefully and make sure that you understand the content fully before working with the safety light curtain.

### 1.1 Scope

These operating instructions only apply to the deTec2 Core safety light curtain with the following type label entry Operating Instructions: 8014274.

These operating instructions are included with SICK part number 8014274 (all available languages).

### 1.2 Target groups and structure of these operating instructions

These operating instructions are intended for the following target groups: project developers (planners, developers, designers), installers, electricians, operators and maintenance personnel.

The structure of these operating instructions is based on the life cycle phases of the safety light curtain: project planning, mounting, electrical installation, commissioning, operation and maintenance.

In many applications, the audiences are assigned as follows to the manufacturer and organization operating the machine, in which the safety light curtain is integrated:

Area of responsibility	Target group	Special chapters of these operating instructions <sup>1)</sup>
Manufacturer	Project developers (planners, developers, designers)	"Project planning", Page 15 "Technical data", Page 47 "Accessories", Page 53
	Installers	"Mounting", Page 24 "Initial commissioning", Page 35 "Checklist for initial commissioning and commissioning", Page 64
	Electricians	"Electrical installation", Page 33
operating company	Operator	"Operation", Page 39 "Troubleshooting", Page 44
	Maintenance personnel	"Maintenance", Page 42 "Troubleshooting", Page 44 "Ordering information", Page 52

<sup>1)</sup> Chapters not listed here are intended for all target groups. All target groups must take into account the safety and warning instructions of the complete operating instructions!

In other applications, the operating organization is also the manufacturer of the equipment with the corresponding allocation of the target groups.

### 1.3 Further information

[www.sick.com](http://www.sick.com) The following information is available on the Internet:

- Other language versions
- Data sheets and application examples
- CAD data of drawings and dimensional drawings
- Certificates (e.g. EC declaration of conformity)
- Guidelines for safe machines (accident prevention with opto-electronic protective devices)

### 1.4 Symbols and document conventions



The following symbols are used in these operating instructions:

**Instructions to action** ► The arrow denotes instructions to action. Read carefully and follow the instructions for action.

**LED symbols** These symbols indicate the status of an LED:

- The LED is off.
- ◐ The LED is flashing.
- The LED is illuminated continuously.

**Sender and receiver** These symbols indicate the sender and receiver of the safety light curtain:

-  The symbol indicates the sender.
-  The symbol indicates the receiver.

**Warnings** A warning indicates an actual or potential risk or dangers. It is designed to help you to prevent accidents. Read carefully and follow the warnings!

The following warning types are used in these operating instructions:



#### CAUTION

Alerts you to a dangerous situation, which can result in a mild to moderate injury if not avoided.

---



#### WARNING

Alerts you to a dangerous situation, which can cause serious injury or death if not avoided.

---



#### DANGER

Alerts you to a dangerous situation, which will cause serious injury or death if not avoided.

---



#### NOTE

The "i" symbol denotes information and alerts you to possible damage and other important information.

---

## 2 Safety information

This chapter contains information on general safety for the safety light curtain.

More safety information about specific usage situations of the safety light curtain is available in the respective chapters.

### 2.1 General safety notes



#### **DANGER**

Risk of ineffectiveness of the protective device

Persons or parts of the body to be protected are not recognized in case of non-observance.

- ▶ Pay particular attention to all warnings in these operating instructions.
- 

### 2.2 Correct use

The deTec2 Core safety light curtain is an electro-sensitive protective device (ESPE) and is suitable for the following applications:

- Hazardous point protection
- Access protection
- Hazardous area protection

The deTec2 Core safety light curtain must be connected to the control such that the machine cannot start while persons are present in the hazardous area. If a person can stand behind the safety light curtain, there must be a restart interlock depending on the applicable national regulations.

The deTec2 Core safety light curtain must be only used within the limits of the prescribed and specified technical data and operating conditions at all times.

The requirements defined in the technical specifications, e.g. power supply, cables and ambient conditions, must be observed and maintained to allow the safety light curtain to meet its warranted function.

If the product is used for any other purpose or modified in any way, any warranty claim against SICK AG shall become void.

**Foreseeable misuse** Among others, the deTec2 Core safety light curtain is **not** suitable for the following applications:

- Outdoors
- Under water
- In potentially explosive atmospheres



**DANGER**

Risk of ineffectiveness of the protective device

Persons and parts of the body to be protected are not recognized in case of non-observance.

- ▶ The width of the protective field must not change during operation of the safety light curtain, see "[Scanning range and protective field width](#)", Page 16.
- ▶ The components of the safety light curtain must not be tampered with, opened or changed. Otherwise, any warranty claim against SICK AG shall become void.
- ▶ Improper repair of the protective device can lead to a loss of the protective function. The protective device must be repaired by the manufacturer or by someone authorized by the manufacturer.

**DANGER**

Risk of ineffectiveness of the protective device

Persons and parts of the body to be protected are not recognized in case of non-observance.

The safety light curtain works as an indirect protective measure and cannot provide protection from parts thrown out nor from emitted radiation. Transparent objects are not detected.

- ▶ Only use the safety light curtain as an indirect protective measure!

## 2.3 Requirements for the qualification of personnel

The safety light curtain must be configured, installed, connected, commissioned and serviced only by qualified safety personnel.

**Project planning** For project planning, a person is considered competent when he/she has expertise and experience in the selection and use of safety equipment on machines and is familiar with the relevant technical rules and national work safety regulations.

**Mechanical installation and commissioning** For mechanical installation and commissioning, a person is considered competent when he/she has the expertise and experience in the relevant field and is sufficiently familiar with the application of the protective device on the machine that he/she can assess its work safety aspects.

**Electrical installation** For electrical installation and commissioning, a person is considered competent when he/she has the expertise and experience in the relevant field and is sufficiently familiar with the application of the protective device on the machine that he/she can assess its work safety aspects.

**Operation and maintenance** For operation and maintenance, a person is considered competent when he/she has the expertise and experience in the relevant field and is sufficiently familiar with the application of the protective device on the machine and has been instructed by the machine operator in its operation.

An operator must clean and check the safety light curtain.

Additional information for the operator of the machine: see "[Operation](#)", Page 39 and "[Regular cleaning](#)", Page 42.

## 3 Product description

This chapter provides information on the operation of the safety light curtain and shows examples of its range of use.

### 3.1 Structure and function

The deTec2 Core safety light curtain is an electro-sensitive protective device (ESPE) consisting of a sender and receiver.

A series of parallel infrared light beams form a protective field between sender and receiver that protects the hazardous area (hazardous point, access and hazardous area protection). When one or more beams are completely interrupted, the safety light curtain reports the interruption in the light path to the secure output signal switching devices (OSSDs) by a signal change. The signal to stop the dangerous state of the machine must be evaluated by a safe control or safety relay (contactors).

Sender and receiver automatically synchronize themselves optically. An electrical connection between both components is not required.

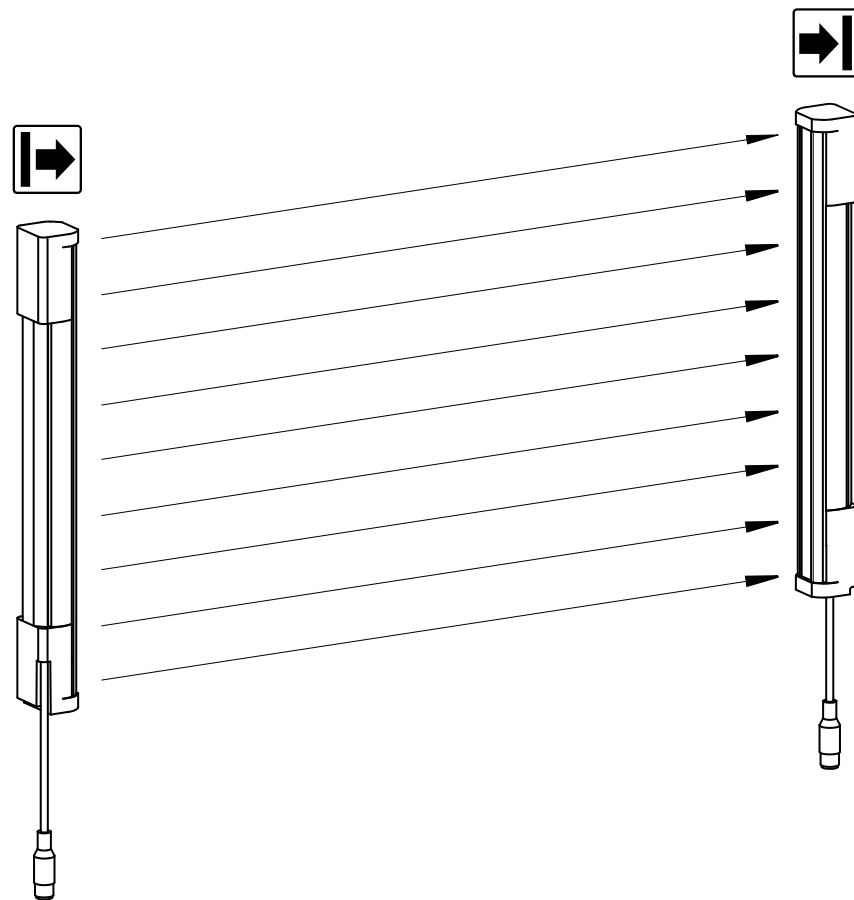

Figure 1: Sender and receiver

**Protective field height** The protective field height indicates the range within which the test rod belonging to the safety light curtain is detected. The size of the safety light curtain determines the protective field height. The design and construction of the safety light curtain deTec2 Core extends the protective function of a device to the end of the housing without any blind spots.

**Protective field range** Die Schutzfeldbreite ist die Länge des Lichtweges zwischen Sender und Empfänger. Sie ist durch die Reichweite begrenzt. Informationen zu Schutzfeldhöhe, Auflösung und Schutzfeldbreite: [see "Data sheet", Page 47.](#)

**Resolution** With the appropriate resolution, the safety light curtain provides finger and hand protection. The resolution corresponds to the diameter of the test rod belonging to the safety light curtain, which is reliably detected when in the protective field.

**Interrelationship: Resolution and scanning range** The deTec2 Core safety light curtain is available with a protective field height of 300 mm to 2100 mm (150 mm steps). The available resolution versions are 14 mm (0 - 7 m scanning range) and 30 mm (0 - 10 m scanning range).

The scanning range is reduced by using deflector mirrors and/or a weld spark guard. Additional information: [see "Deflector mirror", Page 56](#) and ["Weld spark guard", Page 55.](#)

### 3.2 Product characteristics

#### 3.2.1 Absence of blind zones

The design and construction of the safety light curtain extends the protective function of a device to the end of the housing without any blind spots. The absence of blind zones reduces the space requirement when integrated in the machine.

#### 3.2.2 Automatic calibration of the protective field width

When switched on, the safety light curtain automatically calibrates to the protective field width.

#### 3.2.3 Status indicators

The sender and receiver LEDs indicate the operating status of the safety light curtains.

#### Status indicators of the sender

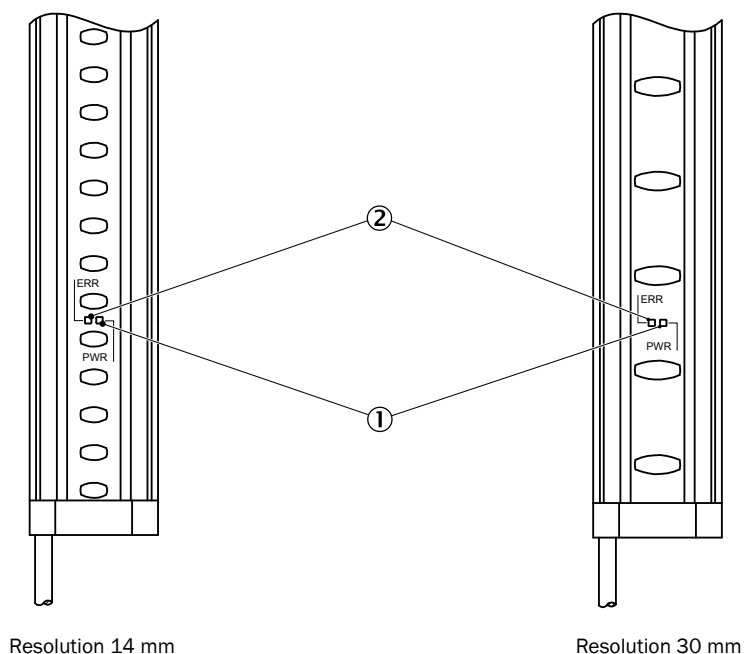

Figure 2: Sender indicators

The sender has two LEDs, which indicate the operating status:

Item	LED color	Display	Labeling
1	Yellow	Status indicator	PWR
2	Red	Fault indicator	ERR

For a complete overview of the fault indications: see ["Fault indicators"](#), Page 44.

#### Status indicators of the receiver

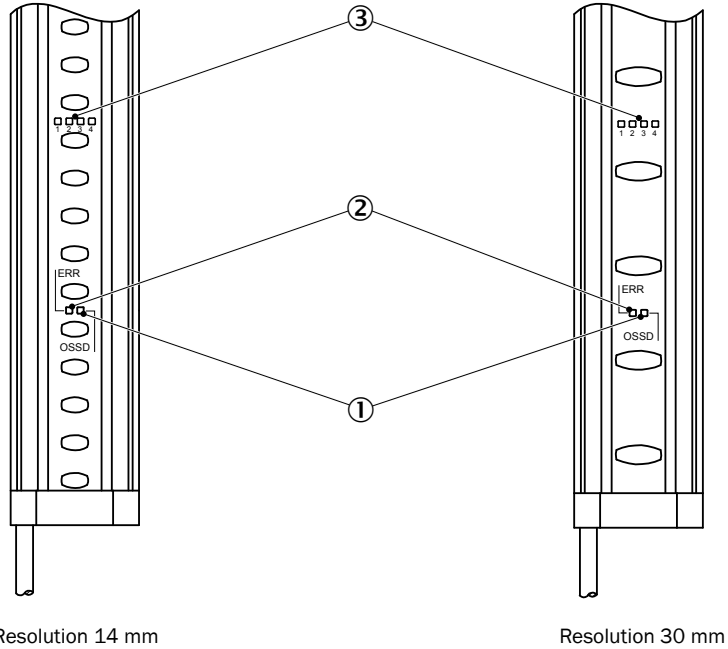

Figure 3: Receiver indicators

The receiver has six LEDs, which indicate the operating status:

Item	LED color	Display	Labeling
1	Red/green	OSSD status indicator	OSSD
2	Red	Fault indicator	ERR
3	Blue	Alignment quality	1, 2, 3, 4

Blue LEDs in combination with the red flashing ERR LED also denote fault indications. For a complete overview of the fault indications: see ["Fault indicators"](#), Page 44.

### 3.3 Example applications

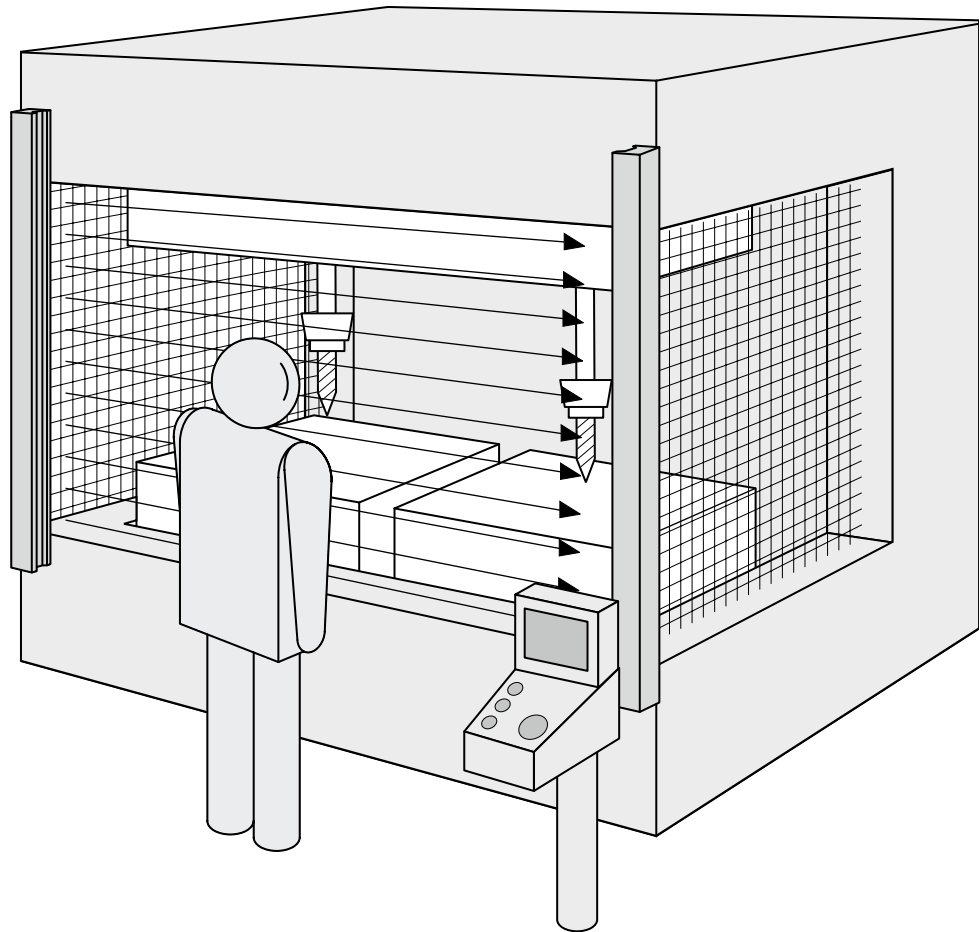

Figure 4: Hazardous point protection

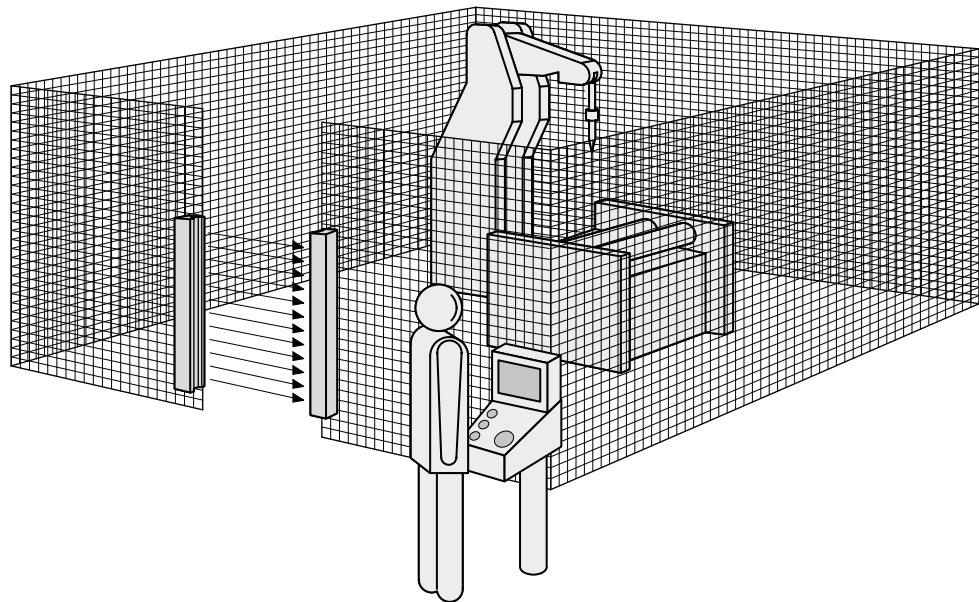

Figure 5: Access protection

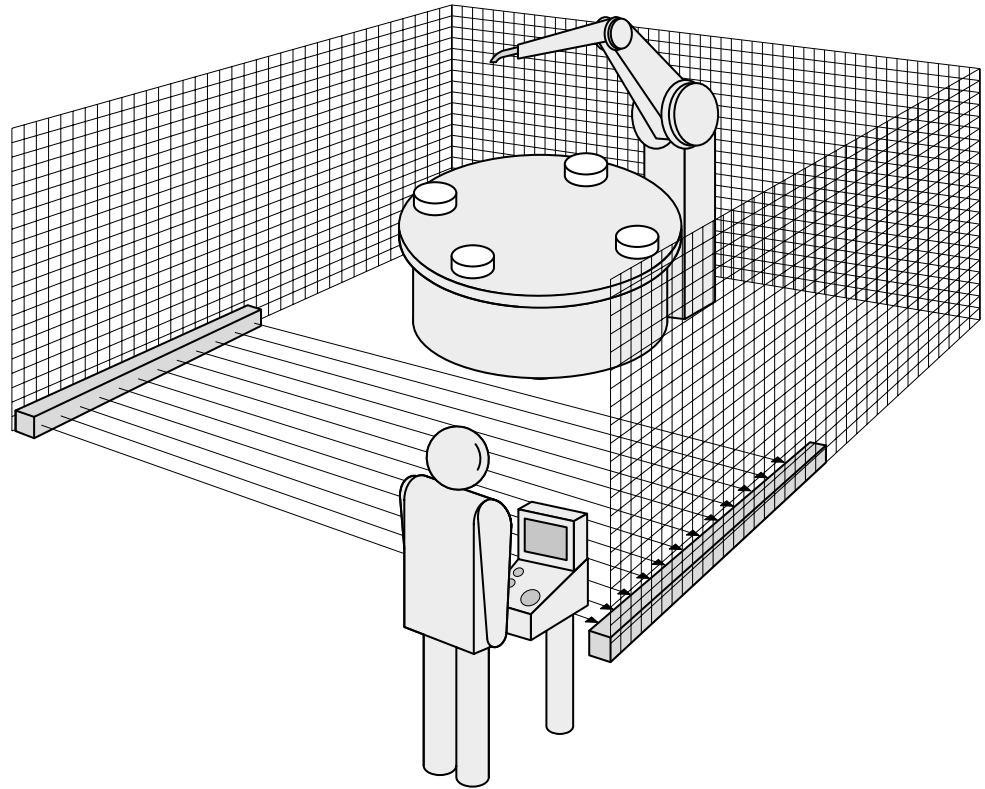

Figure 6: Hazardous area protection

## 4 Project planning

This chapter includes important information about the proper integration of the safety light curtain in machines for planners, developers and designers.

### 4.1 Manufacturer of the machine

---

**DANGER**

Risk of ineffectiveness of the protective device

Persons and parts of the body to be protected are not recognized in case of non-observance.

- ▶ Use of the safety light curtain requires a risk analysis. Check whether additional protective measures are required.
  - ▶ Comply with the applicable national regulations derived from the application (e.g. work safety regulations, safety rules or other relevant safety guidelines).
  - ▶ Do not combine the components of the safety light curtain with components from other safety light curtains.
  - ▶ The components of the safety light curtain must not be tampered with, opened or changed. Otherwise, any warranty claim against SICK AG shall become void.
  - ▶ Improper repair of the protective device can lead to a loss of the protective function. The protective device must be repaired by the manufacture or by someone authorized by the manufacturer.
- 

### 4.2 Operator of the machine

---

**DANGER**

Risk of ineffectiveness of the protective device

Persons and parts of the body to be protected are not recognized in case of non-observance.

- ▶ Changes to the electrical integration of the safety light curtain in the machine control and changes to the mechanical installation of the safety light curtain require another risk analysis.
  - ▶ The results of the risk analysis may require the operator of the machine to meet the obligations of a manufacturer.
  - ▶ The components of the safety light curtain must not be tampered with, opened or changed. Otherwise, any warranty claim against SICK AG shall become void.
  - ▶ Improper repair of the protective device can lead to a loss of the protective function. The protective device must be repaired by the manufacture or by someone authorized by the manufacturer.
- 

### 4.3 Design

This chapter contains important information about the design.

Information about the individual steps for installation of the device: [see "Mounting", Page 24.](#)



### DANGER

Risk of ineffectiveness of the protective device

Persons and parts of the body to be protected are not recognized in case of non-observance.

- ▶ Make sure that the following design requirements are met such that the safety light curtain can fulfill its protective function.

- 
- Sender and receiver must be arranged such that persons or parts of the body are reliably detected when they enter the hazardous area.
  - Reaching under, over and around as well as moving the safety light curtain must be prevented.
  - If people can stop between the protective device and the hazardous point without being detected, check if additional protective measures (e. g. restart interlock with a reset button) are required.

### 4.3.1 Scanning range and protective field width

**Scanning range** The scanning range limits the maximum protective field width. The protective field width cannot change during operation see "Technical data", Page 47.

The scanning range, see "Deflector mirror", Page 56 and "Weld spark guard", Page 55 is reduced by using deflector mirrors and/or a weld spark guard.

**Protective field range** The protective field range is the dimension of the light path between sender and receiver. It is automatically calibrated with switching on the safety light curtain during initialization and must not be changed during operation.



### DANGER

Risk of ineffectiveness of the protective device

Persons and parts of the body to be protected are not recognized in case of non-observance.

- ▶ The safety light curtain can only be mounted to machines on which the protective field width does not change when the safety light curtain is switched on.

### 4.3.2 Minimum distance from the hazardous point

A minimum distance must be maintained between the safety light curtain and the hazardous point. This distance is required to prevent a person or part of the body from reaching the hazardous area before the dangerous state of the machine state has completed.



### DANGER

Risk of ineffectiveness of the protective device

The dangerous state of the machine is not stopped or not stopped in a timely manner for non-compliance.

- ▶ Calculate the required minimum distance for your machine.
- ▶ Mount the safety light curtain taking this calculation into account.

**Calculate minimum distance** The calculation of the minimum distance is based on international and national standards and statutory requirements applicable at the place of installation of the machine.

If the minimum distance is calculated according to ISO 13855, then it depends on the following points:



- Machine stopping time (time interval between triggering the sensor function and the end of the dangerous state of the machine)
- Response time of the protective device see "Response time", Page 49
- Reach or approach speed of the person
- Resolution (detection capability) of the safety light curtain
- Type of approach: orthogonal or parallel
- Parameters specified based on the application

For the USA (scope of OSHA and ANSI), the following regulations apply among others:

- Laws: Code of Federal Regulations, Title 29 (CFR29) Part 1910.217
- Standards: ANSI B11.19



#### NOTE

Additional information is available in the ISO 13855 standard and in the Guidelines Safe Machinery.



#### NOTE

SICK offers to measure the stopping/run-down time as a service in many countries.

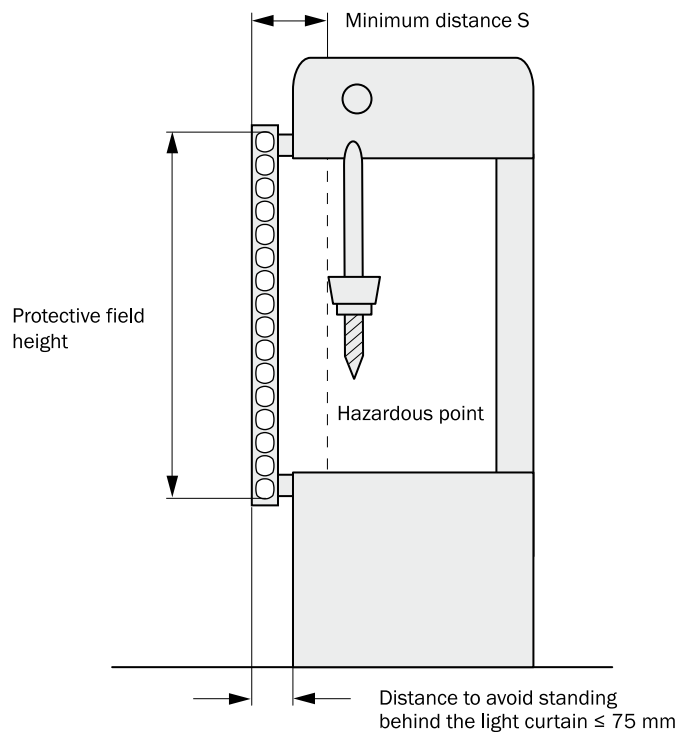

Figure 7: Minimum distance to hazardous point for orthogonal approach to protective field

#### Calculation example of the minimum distance S according to ISO 13855

The example shows the calculation of the minimum distance for orthogonal approach to the protective field. Depending on the application and the ambient conditions (e.g. a protective field parallel or at an arbitrary angle to the direction of approach or an indirect approach), a different calculation may be required.

- First, calculate S using the following formula:  

$$S = 2000 \times T + 8 \times (d - 14) \text{ [mm]}$$

where

- $T$  = machine stopping time + response time of the protective device after interruption in the light path [s]
- $d$  = resolution of the safety light curtain [mm]
- $S$  = minimum distance [mm]

The reach/approach speed is already included in the formula.

- If the result  $S \leq 500$  mm, then use the determined value as the minimum distance.
- If the result  $S$  is  $> 500$  mm, then recalculate  $S$  as follows:  

$$S = 1600 \times T + 8 \times (d - 14) \text{ [mm]}$$
- If the new value  $S$  is  $> 500$  mm, then use the newly determined value as the minimum distance.
- If the new value  $S$  is  $\leq 500$  mm, then use 500 mm as the minimum distance.

**Example calculation** Machine stopping time = 290 ms

Response time after interruption of the light path = 30 ms

Resolution of the safety light curtain = 14 mm

$$T = 290 \text{ ms} + 30 \text{ ms} = 320 \text{ ms} = 0.32 \text{ s}$$

$$S = 2000 \times 0.32 + 8 \times (14 - 14) = 640 \text{ mm}$$

$S > 500$  mm, therefore:

$$S = 1600 \times 0,32 + 8 \times (14 - 14) = 512 \text{ mm}$$

### Taking reaching over into account

If access to the hazardous area cannot be ruled out by reaching over a vertical protective field, the height of the protective field and minimum distance of the ESPE must be determined. This is done by comparing the calculated values based on the possible detection of limbs or body parts with the values resulting from reaching over the protective field. The greater value resulting from this comparison must be used. This comparison is to be carried out according to ISO 13855, Section 6.5 or national regulations.



Figure 8: Representation of the accessibility of ESPE by reaching over. Left: Protective field that cannot be reached over. Right: Protective field that can be reached over.

### 4.3.3 Minimum distance to reflective surfaces



#### DANGER

Risk of ineffectiveness of the protective device

Reflective surfaces and dispersive media can prevent persons or parts of the body to be protected from being properly reflected and therefore, remain undetected.

- ▶ Make sure that all reflective surfaces and objects maintain a minimum distance from the protective field.
- ▶ Make sure that no dispersive media is found within the calculated minimum distance from the protective field.

The light beams from the sender may be deflected by reflective surfaces and dispersive media. This can result in non-detection of an object.

Therefore, all reflective surfaces and objects (e.g. material bins, machine table, etc.) must maintain a minimum distance (a) from the protective field. This minimum distance (a) must be maintained on all sides of the protective field. This applies in horizontal, vertical and diagonal directions as well as at the end of the safety light curtain.

Make sure that no dispersive media is found within the calculated minimum distance from the protective field.

The minimum distance (a) depends on the distance (D) between sender and receiver (protective field width).

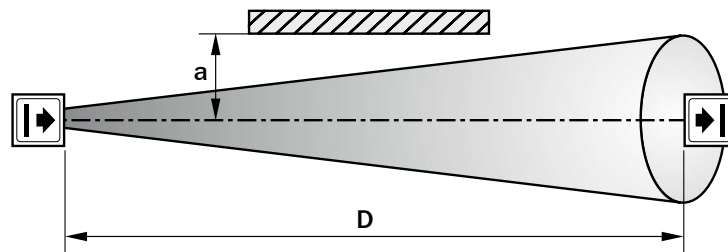

Figure 9: Minimum distance to reflective surfaces

#### How to determine the minimum distance from reflective surfaces:

- ▶ Determine the distance D [m], sender – receiver.
- ▶ Read the minimum distance a [mm] in the graph or calculate it based on the respective formula from [Tab. 1](#):

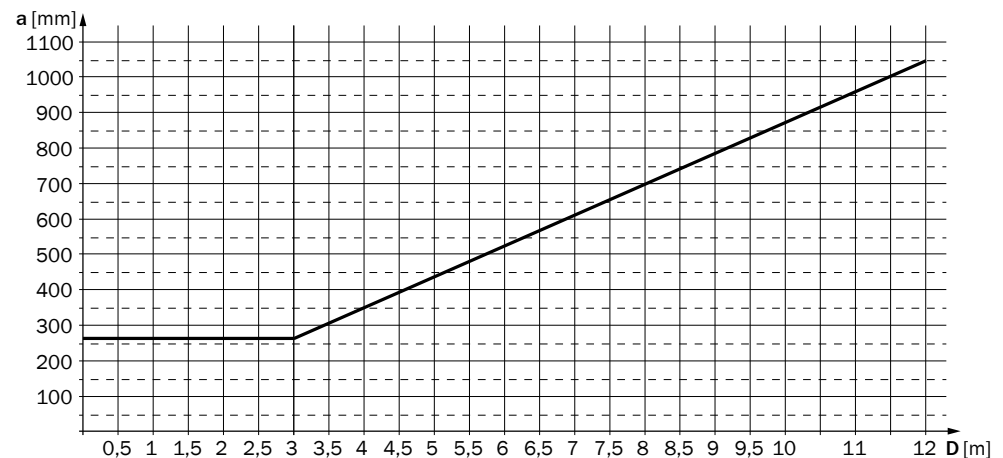

Figure 10: Graph, minimum distance from reflective surfaces

Distance (D) [m] Sender-receiver	Calculation of the minimum distance (a) from reflective surfaces
$D \leq 3$ m	$a$ [mm] = 262
$D > 3$ m	$a$ [mm] = $\tan(5^\circ) \times 1000 \times D$ [m] = $87,49 \times D$ [m]

Table 1: Formula for calculating the minimum distance from reflective surfaces

### 4.3.4 Protection against interference from systems in close proximity to each other

The infrared light beams of the sender of system 1 can interfere with the receiver of system 2. This can disrupt the protective function of system 2. This would mean that the operator is at risk. Avoid such installation situations or take appropriate action, e.g. install optically opaque partitions or reverse the direction of transmission of a system.

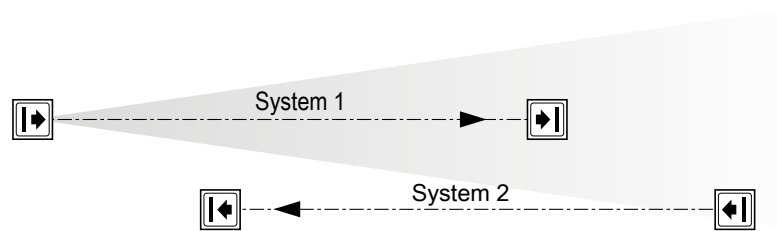

Figure 11: The direction of transmission of systems in close proximity to each other is reversed. The sender of the 2nd system is not affected by the beams 1st system.



#### DANGER

Risk of ineffectiveness of the protective device

Several systems of safety light curtains in close proximity to each other can interfere with each other.

- ▶ Prevent interference from systems in close proximity to each other.

## 4.4 Integration in electrical control

This chapter contains important information about integration in the electrical control. Information about the individual steps for electrical installation of the device: [see "Electrical installation", Page 33.](#)

**Requirements for use** Depending on the safety concept, the signal to stop the dangerous state of the machine must be evaluated by a safe control or safety relay (external control).



#### DANGER

Risk of ineffectiveness of the protective device

Persons and parts of the body to be protected are not recognized in case of non-observance.

- ▶ Make sure that the following control and electrical requirements are met such that the safety light curtain can fulfill its protective function.

- The control of the machine must allow electrical interference.
- The electrical control of the machine must meet the requirements of IEC 60204-1.
- A restart interlock must be implemented depending on applicable national regulations or required reliability of the safety function. Because the safety light curtain does not have this function, it must be implemented in the external control if required.
- When using a safe control, different signal levels of both OSSDs must be detected depending on applicable national regulations or required reliability of the safety function. The maximum time tolerated by the control during which the OSSDs may exhibit different states must be selected according to the application.
- The OSSD1 and OSSD2 output signals must not be connected to each other.
- In the machine controller, the signals of both OSSDs must be processed separately.

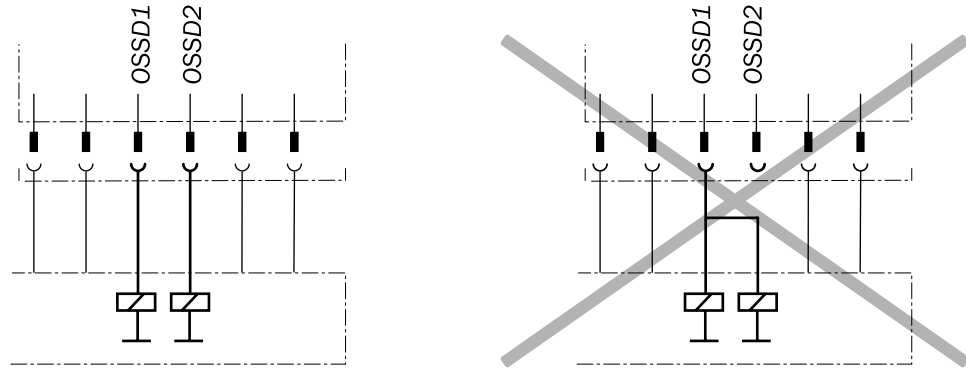

Figure 12: Dual-channel and isolated connection of OSSD1 and OSSD2

- The machine must switch to the safe state at any time if at least one of the two OSSDs switches to the LOW state.
- Prevent the formation of a potential difference between the load and the protective device. If you connect loads to the OSSDs (safety outputs) that then also switch if controlled with negative voltage (e.g. electro-mechanical contactor without reverse polarity protection diode), you must connect the 0 V connections of these loads and those of the corresponding protective device individually and directly to the same 0 V terminal strip. In the event of a fault, this is the only way to ensure that there can be no potential difference between the 0 V connections of the loads and those of the corresponding protective device.

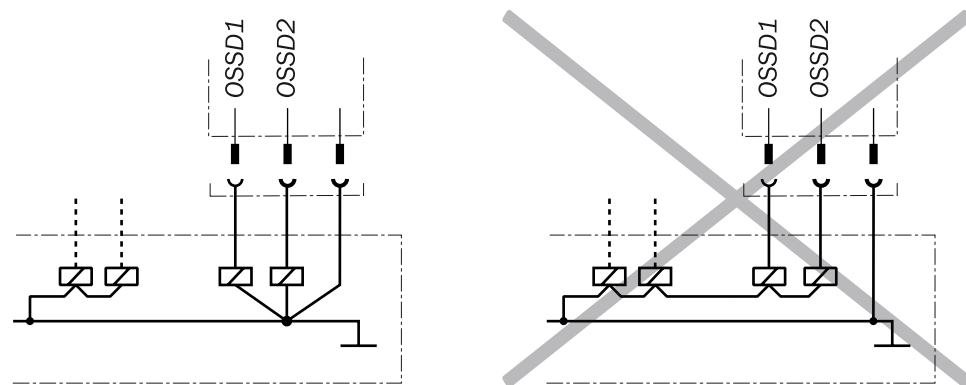

Figure 13: No potential difference between load and protective device



#### DANGER

Risk of ineffectiveness of the protective device

Persons and parts of the body to be protected are not recognized in case of non-observance.

Contactors connected in series must be positively guided and monitored.

- Make sure that contactors connected in series are monitored!

- When using external switching elements (e.g. positively guided contactors), verification of the external switching elements (external device monitoring) must be implemented depending on applicable national regulations or required reliability of the safety function. Because the safety light curtain does not have this function, it must be implemented in the external control if required.

### Requirements for the electrical control of the machine

The two outputs are protected against short-circuits to 24 V DC and 0 V. When the protective field is clear, the signal level on the outputs is HIGH (at potential) and when the light beams are interrupted or there is a device fault the outputs are LOW (over 1.5 kΩ towards 0 V).

The safety light curtain complies with the rules for electromagnetic compatibility (EMC) for the industrial sector (Radio Safety Class A). Radio interference cannot be ruled out when used in residential areas.



#### DANGER

Risk of ineffectiveness of the protective device

Persons and parts of the body to be protected are not recognized in case of non-observance.

► Make sure that the following requirements for electrical control of the machine are met such that the safety light curtain can fulfill its protective function.

- The external power supply of the safety light curtain must be capable of buffering brief power failures of 20 ms as specified in EN 60204-1.
- The power supply unit must provide safe isolation according to IEC 61140 (SELV/PELV). Suitable power supplies are available as accessories from SICK, see ["Ordering information, accessories", Page 53](#).

#### 4.4.1 Restart interlock and external device monitoring

A restart interlock and/or verification of the external switching elements (external device monitoring) must be implemented depending on applicable national regulations or required reliability of the safety function.

##### Restart interlock

A restart interlock prevents the machine from starting again as long as the operator does not explicitly reset it. The dangerous state of the machine (1) is stopped if the light path is interrupted (2) and is not re-enabled (3) until the operator presses the re-set device (4).

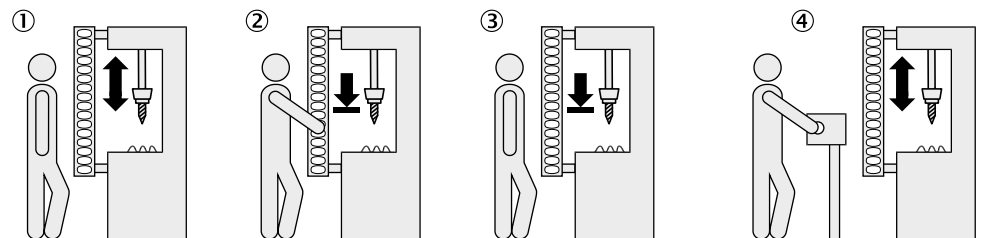

Figure 14: Schematic representation of operation with restart interlock

The restart interlock should not be confused with the start interlock of the machine. The start interlock prevents the machine from starting after switching on. The restart interlock prevents the machine from starting again after a fault or an interruption in the protective field.

There must be a restart interlock depending on the applicable national regulations when a person can stand behind the safety light curtain. The safety light curtain does not have an internal restart interlock. Therefore, a restart interlock must be implemented externally via the circuitry or the control, e.g. in connection with the SICK switching amplifier UE48-20S/UE48-30S.

**External device monitoring (EDM)** The external device monitoring checks if the contactors used to end the dangerous state of the machine de-energize (switch off) when the protective device responds.



#### NOTE

Because the safety light curtain does not have external device monitoring, it must be implemented in the external control.

#### Connection diagram for UE48-20S with restart interlock and external device monitoring

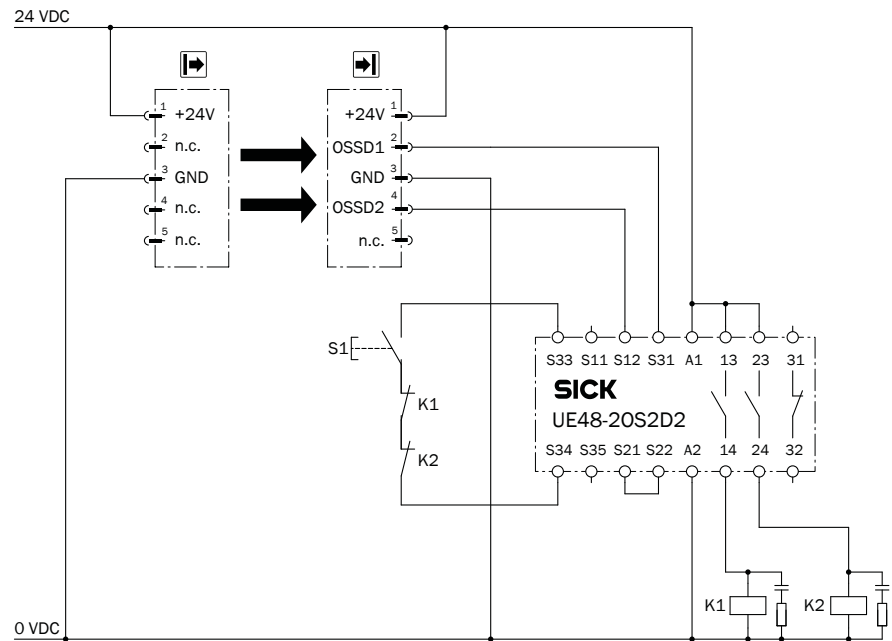

Figure 15: Connection diagram for UE48-20S with restart interlock and external device monitoring

The safety light curtain can be connected to the UE48-20S switching amplifiers. It is operated with restart interlock and external device monitoring.

#### Functionality

When the protective field is clear, the OSSD1 and OSSD2 outputs carry voltage. The system can be switched on when K1 and K2 are in the de-energized position. Pressing the S1 button switches on the UE48 switching amplifier. Contacts 13-14 and 23-24 of the UE48 activate the K1 and K2 contactors.

When the protective field is interrupted, the OSSD1 and OSSD2 outputs carry no voltage. The UE48 switches off and K1, K2 are deactivated.

#### Fault analysis

Failure of K1 and K2 does not cause the loss of the shut-down function. Cross-circuits and short-circuits of the OSSD1 and OSSD2 outputs are recognized and lead to the locking state. It is recognized if the K1 or K2 contactors does not de-energize.

### 5 Mounting

This chapter describes how to mount the safety light curtain using the included Quick-Fix bracket.

A FlexFix bracket is also available with extended adjustment possibilities, [see "Accessories", Page 53](#).

The following steps are necessary after mounting and installation:

- ["Electrical installation", Page 33](#)
- ["Align the sender and receiver", Page 36](#)
- ["Initial commissioning", Page 35](#)



#### NOTE

Mount the safety light curtain in the following order.

---

#### 5.1 Safety

Information about the requirements for properly mounting the safety light curtain [see "Design", Page 15](#).



#### DANGER

Dangerous state of the machine

- ▶ Make sure that the dangerous state of the machine is (and remains) switched off.
  - ▶ Make sure that the outputs of the safety light curtain have no effect on the machine.
- 



#### DANGER

Risk of ineffectiveness of the protective device

Persons or parts of the body to be protected are not recognized in case of non-observance.

- ▶ Only use brackets recommended by SICK for mounting.
  - ▶ Take appropriate measures for vibration dampening if the vibration and shock requirements are above the values and test conditions specified in the data sheet, [see "Data sheet", Page 47](#).
- 

#### 5.2 Unpacking

- ▶ Check the components for completeness and the integrity of all parts, [see "Scope of delivery", Page 52](#).
- ▶ Please contact your respective SICK subsidiary should you have any complaints.

#### 5.3 Installation

The QuickFix bracket or the optional FlexFix bracket is used to mount the sender and receiver. In many cases, the QuickFix bracket is enough for installation. The FlexFix bracket makes it possible to rotate sender and receiver around the axis of the device and to align it accurately.



**DANGER**

Risk of ineffectiveness of the protective device

Persons or parts of the body to be protected are not recognized or not recognized in time in case of non-observance.

- ▶ It is vital that you observe the minimum distance calculate for your machine: see ["Minimum distance from the hazardous point", Page 16](#) and see ["Minimum distance to reflective surfaces", Page 18](#)
- ▶ Mount the safety light curtain such that the hazardous point cannot be reached from below, above or behind the safety light curtain and that the light curtain cannot be repositioned.

**NOTE**

- ▶ Read this section completely before mounting the brackets.
- ▶ Read the section ["Align the sender and receiver", Page 36](#)

**Mounting instructions**

- ▶ Mount the sender and receiver on a level surface.
- ▶ Mount the sender and receiver at the same height. For minor adjustments when aligning, the sender and receiver can be adjusted vertically in the brackets, see ["Fig. 27: QuickFix bracket: adjust vertically", Page 36](#) and see ["Fig. 28: FlexFix bracket: adjust vertically / rotate", Page 37](#).
- ▶ When possible, mount the top bracket at a height such that the offset in the housing of the safety light curtain sites on the bracket to prevent the safety light curtain from sliding down.
- ▶ The end with the cable connection must point in the same direction for both devices.

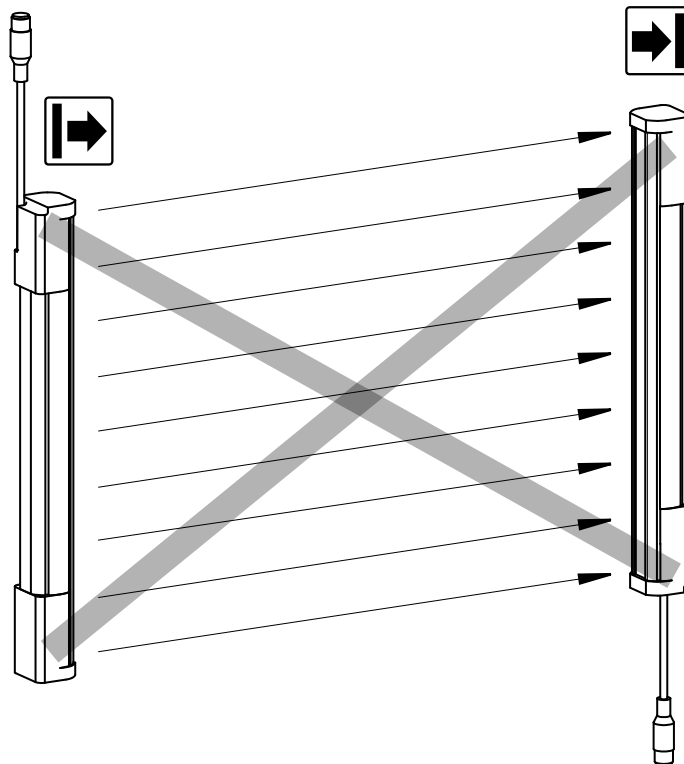

Figure 16: Sender and receiver must not be installed at 180° rotated relative to each other.

- ▶ Tighten the screws used to mount the bracket at a torque of 5 - 6 Nm. Tighten the screws used to secure the safety light curtain in the bracket at a torque of 2.5 - 3 Nm. Higher torques can damage the bracket while lower torques do not provide adequate fixation to prevent the safety light curtain from moving in the event of vibrations.
- ▶ When mounting, make sure that sender and receiver are aligned correctly. The optical lens systems of sender and receiver must be located in opposition to each other.
- ▶ If necessary, use a water level to check the parallelism of the components.

### 5.3.1 Mount the QuickFix bracket

QuickFix brackets can be mounted in two ways:

- On the side
- On the back

The two mounting surfaces for the brackets of the sender or receiver must not be angled more than  $0.5^\circ$  to each other. If not possible, use the optional FlexFix bracket.

#### Mount QuickFix bracket on the side of a machine or profile frame

Two QuickFix brackets are used to mount the sender and receiver.

The QuickFix bracket consists of two parts, which are pushed into each other. An M5 screw is used to join both parts and to clamp the housing (sender or receiver).

Mounting can be carried out in two ways:

- ▶ With the M5 screw through the QuickFix bracket to the machine or profile frame. A screw nut or threaded hole is required on the machine or profile frame.
- ▶ With the M5 screw through the machine or profile frame to the QuickFix bracket. A screw nut is required for each QuickFix bracket.
- ▶ When choosing the length of the M5 screw (hexagon head or cylinder head screw), consider the QuickFix bracket and the machine or profile frame.



#### CAUTION

Risk of injury from protruding screws thread

When mounting through the machine or profile frame to the QuickFix bracket, the M5 screw can present an injury risk if too long.

- ▶ Select an appropriate screw length to prevent any risk of injury from an overrun.
-

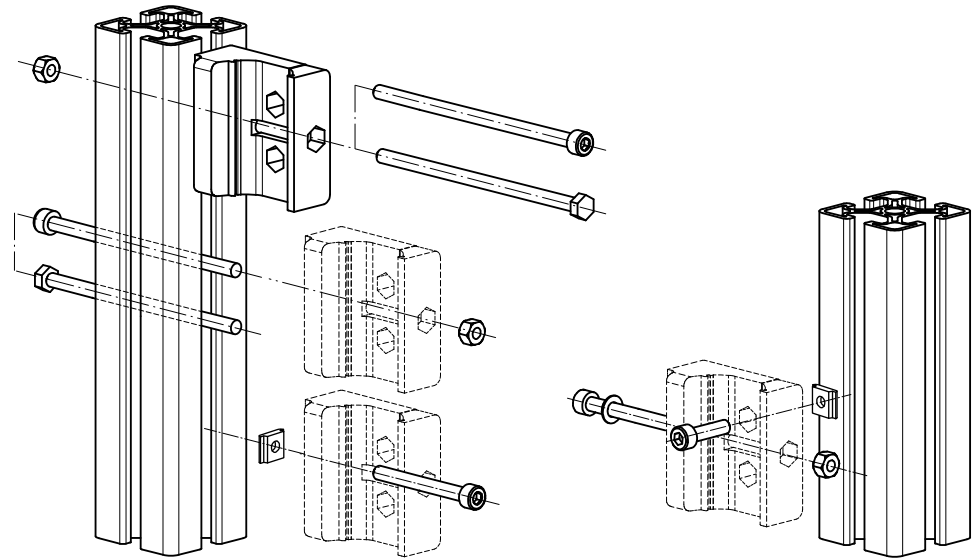

Figure 17: Mount QuickFix bracket to a profile



**NOTE**

The QuickFix bracket has cable routing. Depending on the installation, the cable routing can make mounting easier.

### 5.3.2 Mount optional FlexFix bracket

In the FlexFix bracket, sender and receiver can be flexibly rotated by  $\pm 15^\circ$ . FlexFix brackets can be mounted in two ways:

- On the side
- On the back



**NOTE**

Use flat head screws for rear-side mounting of FlexFix holders so that the safety light curtain housing cannot be scratched by any protruding screw heads.

#### Mount FlexFix bracket on the side of a machine or profile frame

Two FlexFix brackets are used to mount the sender and receiver at the designated points.

The M5 screws are used to mount through the FlexFix bracket to the machine or profile frame. A screw nut or threaded hole is required on the machine or profile frame.

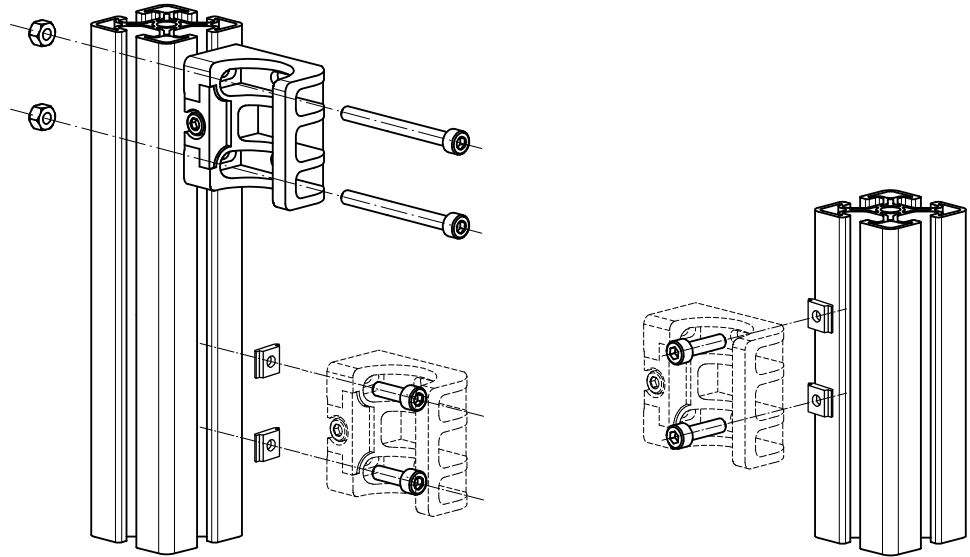

Figure 18: Mount FlexFix bracket to a profile frame

- ▶ After mounting the FlexFix brackets, screw the sender or receiver into the FlexFix brackets from the front and align the sender and receiver, see ["Align the sender and receiver"](#), Page 36.



### NOTE

The safety light curtain can only be screwed in when both FlexFix brackets are in alignment. A water level can be used to help. If necessary, use a water level to check the parallelism of the components.

---

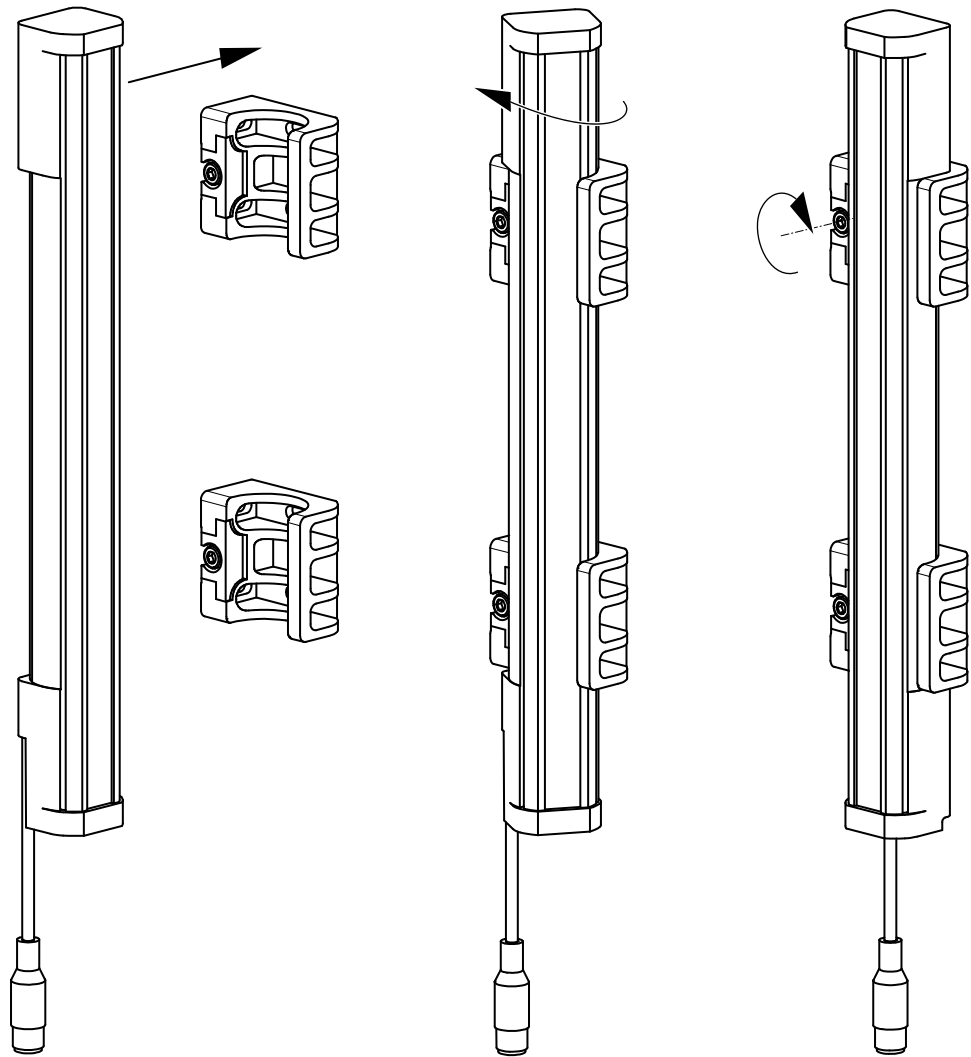

Figure 19: Inserting the safety light curtain in the FlexFix brackets

- ▶ Use an M5 screw to fix the position of the sender and receiver in the FlexFix bracket.

#### Mount FlexFix bracket to the back of a device column

Two FlexFix brackets are used to mount the sender and receiver. Two M5 screws are required to mount a FlexFix bracket. A FlexFix bracket can be mounted to a device column with two sliding nuts in the groove of the device column.



#### NOTE

The BEF-1SHABBKU2 mounting kit contains two FlexFix brackets and the required screws and sliding nuts, see "Ordering information, accessories", Page 53.

- ▶ After mounting the FlexFix brackets, screw the sender or receiver into the FlexFix brackets from the front and align the sender and receiver, see "Align the sender and receiver", Page 36.
- ▶ Use an M5 screw to fix the position of the sender and receiver in the FlexFix bracket.

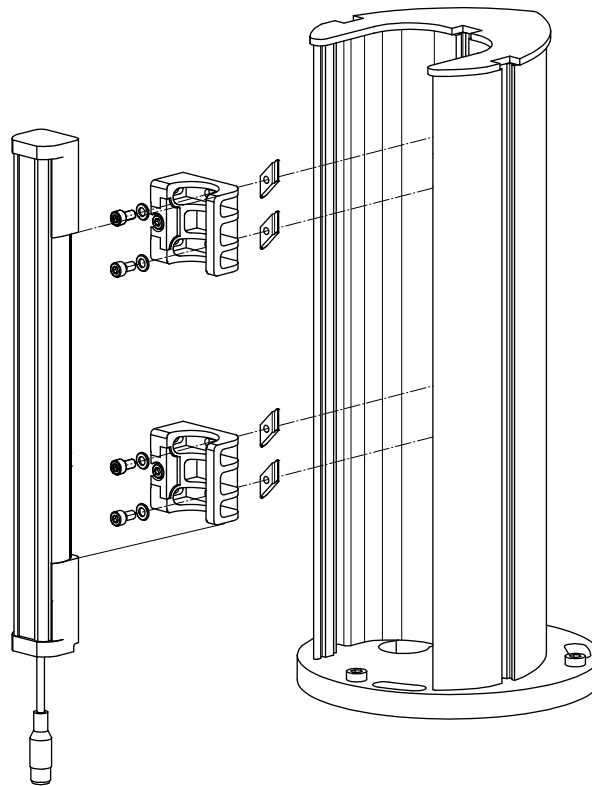

Figure 20: Mount FlexFix bracket to a device column (accessory)

### 5.3.3 Mount optional replacement bracket

If an existing C2000 safety light curtain is mounted with a swivel-mount bracket or with a side bracket, it can be replaced with a deTec2 Core safety light curtain using a replacement bracket. There is no need to drill new holes, since the existing ones can be used for the replacement bracket.

- ▶ Use one of the following installation versions independent of the existing situation that prevails:
  - To replace a swivel mount bracket (article number 2019649 or 2019659): installation version A or B
  - To replace a side bracket (article number 2019506): installation version C

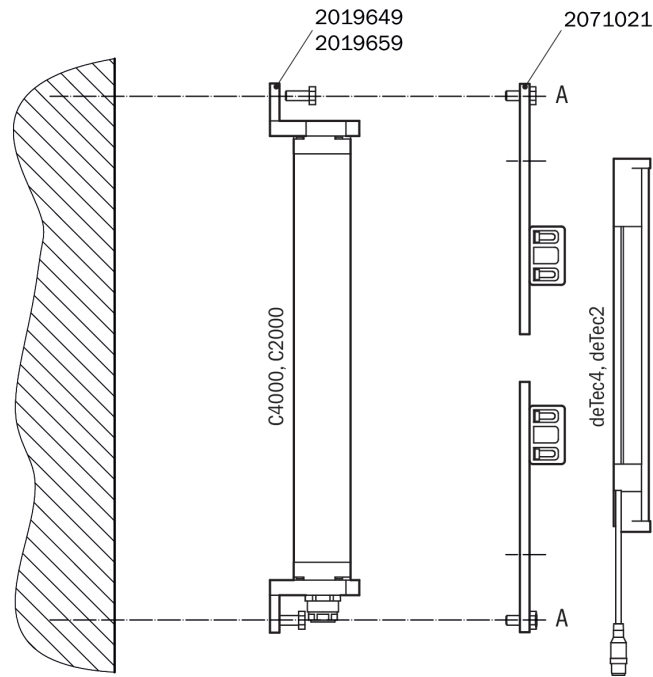

Figure 21: Replacement bracket, installation version A

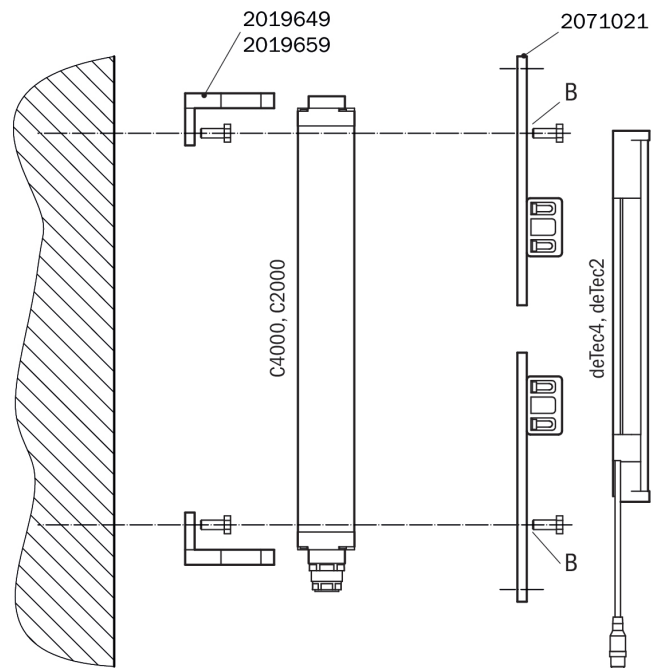

Figure 22: Replacement bracket, installation version B

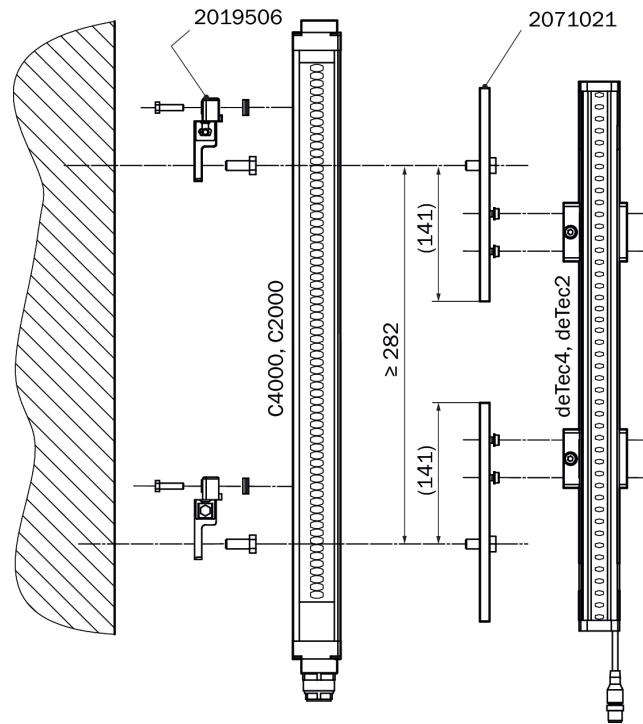

Figure 23: Replacement bracket, installation version C

#### 5.4 Attach information label

- ▶ Use the "Important Information" label in the language of the operator of the machine. Use several information labels if additional languages are required for other operators.
- ▶ Affix "Important Information" label to the machine in close proximity to sender and receiver. The information label is self-adhesive.
- ▶ Affix the information label such that it is easily visible by each operator during operation. After attaching additional objects and equipment, the information label must not be concealed from view.



## 6 Electrical installation

This chapter describes the electrical installation of the safety light curtain.

### 6.1 Safety

Information about the requirements that must be met for safe integration of the safety light curtain in the control and electronics of the machine: see ["Integration in electrical control"](#), Page 20.

Mounting should be completed before electrical installation.



#### DANGER

Risk of electric shock

Risk of the machine starting unexpectedly

- ▶ Make sure that the machine is (and remains) disconnected from the power supply during the electrical installation.
- ▶ Make sure that the dangerous state of the machine is (and remains) switched off.
- ▶ Only use an appropriate power supply, see ["Technical data"](#), Page 47.
- ▶ Make sure that the outputs of the safety light curtain have no effect on the machine during the electrical installation.



#### DANGER

Risk of ineffectiveness of the protective device

- ▶ Connect OSSD1 and OSSD2 separately. OSSD1 and OSSD2 must not be connected to each other. Otherwise, signal safety will not be ensured.

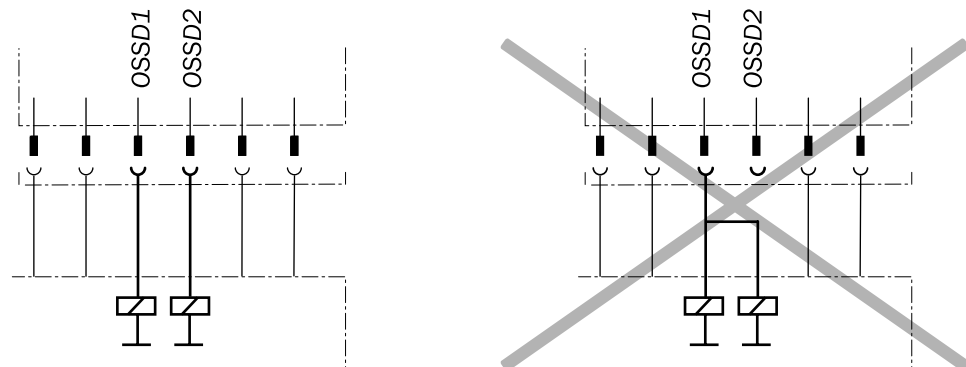

Figure 24: Connection of OSSD1 and OSSD2



#### DANGER

Risk of ineffectiveness of the protective device

- ▶ Prevent the formation of a potential difference between the load and the protective device.

- ▶ If you connect loads to the OSSDs (safety outputs) that then also switch if controlled with negative voltage (e.g. electro-mechanical contactor without reverse polarity protection diode), you must connect the 0 V connections of these loads and those of the corresponding protective device individually and directly to the same 0 V terminal strip. In the event of a fault, this is the only way to ensure that there can be no potential difference between the 0 V connections of the loads and those of the corresponding protective device.

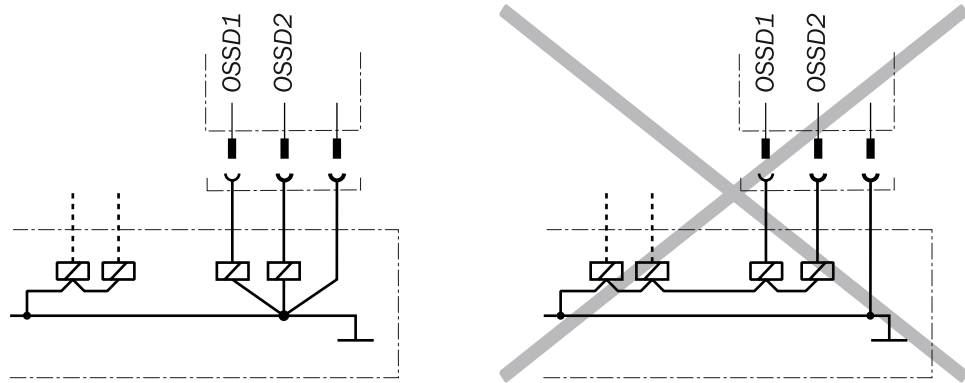

Figure 25: No potential difference between load and protective device

### 6.2 Device connection (M12, 5-pin)

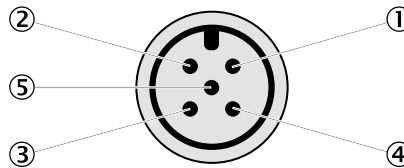

Figure 26: Sender and receiver

Pin	Wire color	Sender	Receiver
1	brown	24 V DC input (power supply)	24 V DC input VDC24 (power supply)
2	White	Reserved	OSSD1 (output signal switching device 1)
3	Blue	0 V DC input (power supply)	0 V DC input (power supply)
4	black	Reserved	OSSD2 (output signal switching device 2)
5	gray	Not yet assigned	Not yet assigned

Table 2: Device connection pin assignment (M12, 5-pin)

Connection diagram for the electrical installation: see ["Integration in electrical control", Page 20](#).

### 6.3 Device connection via connection cable (M12, 5-pin to 8-pin)

An optional connection cable is available to connect the 5-pin device connection to an existing 8-pin socket. The connection cable can be used to replace an existing C2000 safety light curtain with a deTec2 Core, without having to route new cables.

## 7 Initial commissioning

The mounting and electrical installation must be completed before initial commissioning as described in the following chapters.

- "Design", Page 15
- "Integration in electrical control", Page 20
- "Mounting", Page 24
- "Electrical installation", Page 33

### 7.1 Safety



#### **DANGER**

Risk of ineffectiveness of the protective device

When changes are made to machines, the effectiveness of the protective device may be affected unintentionally.

- ▶ After every change to the machine and changes to the integration and/or operational and secondary conditions of the safety light curtain, check the protective device for effectiveness and recommission as specified in this chapter.



#### **DANGER**

Dangerous state of the machine

- ▶ Make sure that the dangerous state of the machine is (and remains) switched off.



#### **DANGER**

Risk of ineffectiveness of the protective device

- ▶ Before you operate a machine protected by the safety light curtain for the first time, make sure that the machine is first checked and released by qualified safety personnel.
- ▶ Make sure that the optical properties of the front screen of the sender and receiver are not changed by beading water, mist, frost or ice formation.
- ▶ Make sure that all reflective surfaces and objects maintain a minimum distance from the protective field.
- ▶ Make sure that no dispersive media is found within the calculated minimum distance from the protective field.
- ▶ Only operate the machine when the protective function of the safety light curtain is operating properly.

### 7.2 Switching on

After switching on, initialize the sender and receiver. All LEDs of the sender and receiver briefly light up. After initialization, the receiver displays the alignment quality using four blue LEDs. The alignment indicator goes out after a certain time after the safety light curtain is aligned (OSSD LED: green) and only the PWR LED of the sender and OSSD LED of the receiver illuminate.

In the event of a fault, the red fault LED flashes on the respective device. The red fault LED in combination with the blue LEDs show the cause of the fault on the side of the receiver, see "Troubleshooting", Page 44.

### 7.3 Align the sender and receiver

After mounting and the electrical installation, the sender and receiver must be aligned with each other.



**DANGER**

Dangerous state of the machine

- ▶ Make sure that the outputs of the safety light curtain have no effect on the machine during the alignment process.

**Alignment with the QuickFix bracket**

You have the following adjustment options with the QuickFix bracket:

- Adjust vertically (H)

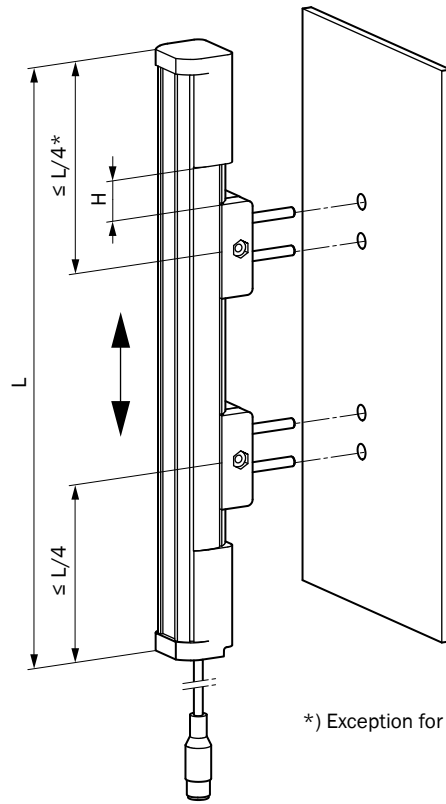

\*) Exception for protective field height 300 mm

Figure 27: QuickFix bracket: adjust vertically



**NOTE**

If the alignment cannot be adjusted with the QuickFix bracket, use the optional FlexFix bracket.

Indication of the alignment quality

Display		Meaning
Blue LEDs	OSSD LED	
No LED lights up	Red	Alignment is insufficient or the protective field is interrupted at least partially. The receiver cannot synchronize with the sender.
1 LED lights up	Red	Alignment is insufficient or the protective field is interrupted at least partially.
2 LEDs light up	Red	Alignment is poor or the protective field is interrupted at least partially.
2 LEDs light up	Green	Alignment is not yet sufficient for stable availability.
3 LEDs light up	Green	Alignment is good, stable availability. <sup>1)</sup>
4 LEDs light up	Green	Alignment is very good.

Table 3: Blue LEDs to indicate the alignment quality

<sup>1)</sup> At a typical scanning range, there is a possibility that all four LEDs to indicate alignment quality do not light up even when alignment is good.



**NOTE**

Once the system is aligned, at least two blue LEDs light up and the OSSD LED is green.

Aligning with the FlexFix bracket or with the replacement bracket

You have the following adjustment options with the FlexFix bracket or the replacement bracket:

- Adjust vertically (H)
- Rotate (+/- 15 °)

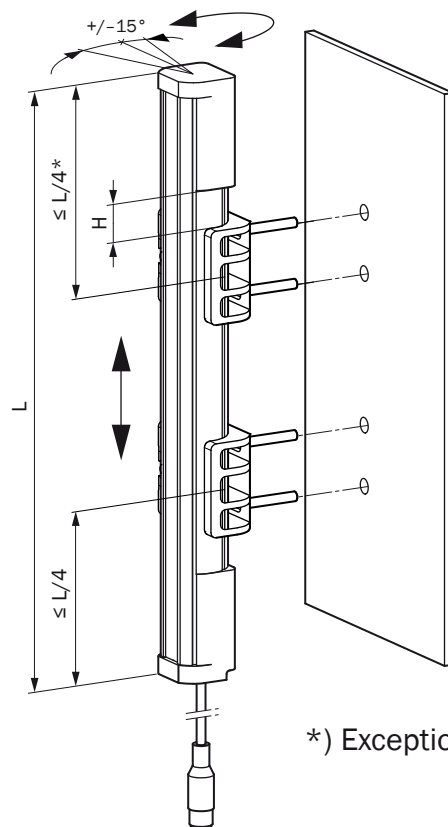

Figure 28: FlexFix bracket: adjust vertically / rotate

**Align the sender and receiver to each other** How to align sender and receiver with FlexFix bracket or with the replacement bracket:

- ▶ Switch on the power supply to the safety light curtain.
- ▶ Pay attention to the mounting heights of sender and receiver.
- ▶ Provide a rectangular protective field.
- ▶ Roughly align the sender to the receiver by rotating the sender.
- ▶ Roughly align the receiver to the sender by rotating the receiver.
- ▶ Look for the four blue LEDs of the receiver. The LEDs signal the alignment quality. Adjust the sender and receiver such that as many blue LEDs illuminate as possible.
- ▶ If the receiver switches to "Green", secure the components in the brackets at a torque of 2.5 - 3 Nm.
- ▶ Switch off the power supply and on again.
- ▶ Check the blue LEDs to make sure that the components are still correctly aligned with each other.



### NOTE

Once three blue LEDs illuminate, alignment is good and availability is stable.

---



### NOTE

The optional laser alignment aid AR60 can be used for alignment, see ["Ordering information, accessories"](#), Page 53.

Since the laser alignment assistant is placed in the protective field of the safety light curtain with the adapter, the indicator for the alignment quality shows a maximum of two blue LEDs and the OSSD LED is red. To check whether the OSSD LED of the receiver is illuminating green, remove the laser alignment assistant.

---

## 7.4 Checks

The purpose of the checks described in the following is to confirm the safety requirements specified in the national/international rules and regulations, especially the safety requirements in the Machine (EU Conformity) or Work Equipment Directive.

These checks are also used to check the effectiveness of the protective device.

These checks must therefore always be performed.

### Checks before initial commissioning/ commissioning

- ▶ The checks must be carried out by qualified safety personnel or specially qualified and authorized personnel and must be recorded and documented to ensure that the tests can be reconstructed and retraced at any time.
- ▶ Check the effectiveness of the protective device for all operating modes selectable on the machine ["Checklist for initial commissioning and commissioning"](#), Page 64 in the appendix.
- ▶ Make sure that the operating personnel have been instructed in the function of the protective device before being allowed to operate the machine. Instructing the operating personnel is the responsibility of the organization operating the machine and must be conducted by qualified personnel.
- ▶ Please note the test notes for the operator in chapter ["Daily check"](#), Page 39.

## 8 Operation

This chapter describes the operation of the safety light curtain that primarily consists of checking the effectiveness of the protective device on a daily basis.

These operating instructions do not provide information on operating the machine in which the safety light curtain is integrated.

### 8.1 Safety



#### DANGER

Risk of ineffectiveness of the protective device after changes

Persons and parts of the body to be protected are not recognized in case of non-observance.

- ▶ Maintenance work, alignment work, fault diagnoses and any changes to the integration of the safety light curtain in the machine must only be carried out by qualified personnel.
- ▶ Then check the effectiveness of the protective device and recommission as specified in chapter "[Initial commissioning](#)", [Page 35](#).



#### DANGER

Risk of ineffectiveness of the protective device

Persons and parts of the body to be protected are not recognized in case of non-observance.

- ▶ Make sure that the optical properties of the front screen of the sender and receiver are not changed by beading water, mist, frost or ice formation.
- ▶ Make sure that all reflective surfaces and objects maintain a minimum distance from the protective field, see "[Minimum distance to reflective surfaces](#)", [Page 18](#).
- ▶ Make sure that no dispersive media is found within the calculated minimum distance from the protective field.

### 8.2 Daily check

#### Checking the effectiveness with the test rod

The effectiveness of the protective device must be checked daily using the included test rod. The diameter of the test rod corresponds to the resolution of the light curtain.

Before introducing the test rod, check if the OSSD LED illuminates green. If not, then you must first change this state. The check is otherwise meaningless.



#### DANGER

Risk of ineffectiveness of the protective device

Persons and parts of the body to be protected are not recognized in case of non-observance.

- ▶ Only use the included test rod with the diameter specified on the type label of the safety light curtain.
- ▶ Do not use any test rods with a similar or the same diameter of other safety light curtains.



**DANGER**

Risk of the machine starting unexpectedly

- ▶ Make sure that the dangerous state of the machine is (and remains) switched off during the check.
- ▶ Make sure that the outputs of the safety light curtain have no effect on the machine while checking the components.

- ▶ Move the test rod slowly through the protective field to be tested as indicated by the arrow in [Fig. 29](#). Watch the OSSD LED on the receiver during the check. The OSSD LED on the receiver should continuously light up red. The OSSD LED may not light up green.

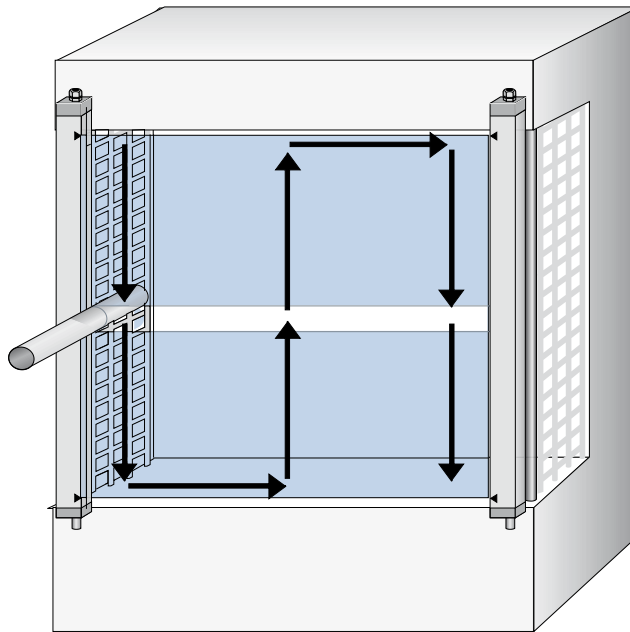

Figure 29: Daily checks of the protective device: Step 1

- ▶ Guide the test rod along the edges of the protective field as indicated by the arrow in [Fig. 30](#). Watch the OSSD LED on the receiver during the check. The OSSD LED on the receiver should continuously light up red. The OSSD LED may not light up green.



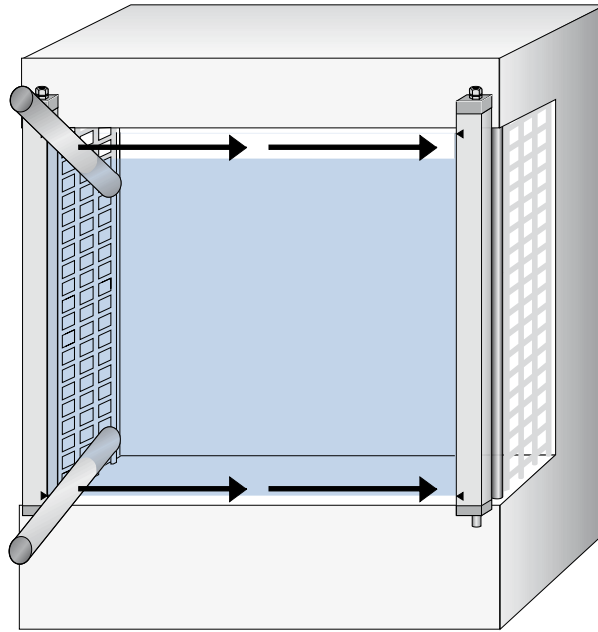

Figure 30: Daily checks of the protective device: Step 2

- ▶ If you use one or more deflector mirrors (see "Accessories", Page 53), then also guide the test rod slowly through the protective field directly in front of the deflector mirrors.  
Watch the OSSD LED on the receiver during the check. The OSSD LED on the receiver should continuously light up red. The OSSD LED may not light up green.



#### **DANGER**

Risk of ineffectiveness of the protective device

Persons and parts of the body to be protected are not recognized in case of non-observance.

Do not operate the machine if the OSSD LED lights up green during the test!

- ▶ If the OSSD LED lights up green during the test even if only briefly, work must stop at the machine.
- ▶ In this case, the mounting and electrical installation of the safety light curtain must be checked by qualified safety personnel, see "Mounting", Page 24, "Electrical installation", Page 33.

## 9 Maintenance

The safety light curtain is maintenance-free. Depending on the ambient conditions, regular cleaning is required.

### 9.1 Safety



#### **DANGER**

Risk of ineffectiveness of the protective device

Persons and parts of the body to be protected are not recognized in case of non-observance.

- ▶ Do not conduct any repairs on the device components (sender, receiver).
  - ▶ Do not open the device components.
- 

### 9.2 Regular cleaning



#### **DANGER**

Risk of ineffectiveness of the protective device

Persons and parts of the body to be protected are not recognized in case of non-observance.

- ▶ Regularly check the degree of contamination on all components based on the application conditions.
  - ▶ Please observe the chapter "[Daily check](#)", Page 39.
- 

Depending on the ambient conditions of the safety light curtain, the front screens must be cleaned regularly and in the event of contamination. Static charges can cause dust particles to be attracted to the front screen. The weld spark guard and deflector mirror must be cleaned regularly and in the event of contamination.

---



#### **DANGER**

Risk of ineffectiveness of the protective device

Persons and parts of the body to be protected are not recognized in case of non-observance.

- ▶ Make sure that the optical properties of the front screens of the sender and receiver are not changed by:
    - beading water, mist, frost or ice formation. If necessary, remove any residues of this type or any other form of contamination and restart the receiver.
    - Scratches or damage. If necessary, replace the respective sender or receiver if its front screen is scratched or damaged.
  - ▶ Make sure that all reflective surfaces and objects maintain a minimum distance from the protective field.
  - ▶ Make sure that no dispersive media is found within the calculated minimum distance from the protective field.
-

**DANGER**

Risk of the machine starting unexpectedly

- ▶ Make sure that the dangerous state of the machine is (and remains) switched off while cleaning.
- ▶ While cleaning, the outputs of the safety light curtain are not allowed to have any effect on the machine.

**NOTE**

- ▶ Do not use aggressive cleaning agents.
- ▶ Do not use abrasive cleaning agents.
- ▶ We recommend anti-static cleaning agents.
- ▶ We recommend the use of anti-static plastic cleaner (SICK part number 5600006) and the SICK lens cloth (SICK part number 4003353).

How to clean the front screen

- ▶ Use a clean, soft brush to remove dust from the front screen.
- ▶ Then wipe the front screen with a clean, damp cloth.
- ▶ Check the position of sender and receiver after cleaning.
- ▶ Check the effectiveness of the protective device. Information on the testing procedure, see ["Daily check", Page 39](#).

### 9.3 Regular inspection

**DANGER**

Risk of ineffectiveness of the protective device

Persons and parts of the body to be protected are not recognized in case of non-observance.

- ▶ The checks must be carried out by qualified safety personnel or specially qualified and authorized personnel and must be recorded and documented to ensure that the tests can be reconstructed and retraced at any time.

- ▶ Check the machine following the inspection intervals specified in the national rules and regulations. This procedure ensures that any changes to the machine or manipulations of the protective device are detected after initial commissioning.
- ▶ Check the machine again according to the checklist in the appendix, see ["Checklist for initial commissioning and commissioning", Page 64](#):
  - If changes are made to the machine or protective devices (e.g. changes to the mechanical, electrical, optical connection)
  - If sender or receiver have been replaced

#### Safety signs, information labels

- ▶ Regularly check the information labels for the following points:
  - Presence
  - Readability
- ▶ Replace the information labels if missing, damaged or illegible.
- ▶ Please observe the chapter ["Attach information label", Page 32](#).

## 10 Troubleshooting

This chapter describes how you identify and remedy faults that interrupt the function of the safety light curtain.

### 10.1 Safety



**DANGER**

Risk of ineffectiveness of the protective device

Persons and parts of the body to be protected are not recognized in case of non-observance.

- ▶ Immediately put the machine out of operation if the behavior of the machine cannot be clearly identified.
- ▶ Immediately put the machine out of operation if you cannot clearly identify or allocate the fault and if you cannot safely remedy the fault.
- ▶ Secure the machine such that it cannot be switched on unintentionally.



**DANGER**

Risk of the machine starting unexpectedly

- ▶ Secure the machine such that it cannot be switched on unintentionally.



**NOTE**

If you cannot remedy a fault with the help of the information provided in this chapter, please contact your respective SICK subsidiary.

### 10.2 Fault indicators

In the event of a fault, the type of fault is indicated by the LED display on the sender or receiver.

Sender	PWR LED (yellow)	ERR LED (red)	Possible cause	Rectification
	○	○	No operating voltage or operating voltage is too low or internal fault	Check the power supply, see "Technical data", Page 47. Switch off the power supply and on again. If the fault persists, replace the sender, see "Ordering information", Page 52.
	○	☀	The voltage was too high when operating the sender.	Check the power supply, see "Technical data", Page 47. Replace the sender, see "Ordering information", Page 52.

Table 4: Fault indicator on the sender

PWR LED (yellow)	ERR LED (red)	Possible cause	Rectification
●	☉	Fault in the supply voltage	Check the voltage supply and power supply, see <a href="#">"Technical data"</a> , Page 47. Switch off the power supply and on again. If the fault persists, replace the defective components, see <a href="#">"Ordering information"</a> , Page 52.
☉	☉	The sender identified an internal fault.	Switch off the power supply and on again. If the fault persists, replace the sender, see <a href="#">"Ordering information"</a> , Page 52.

Table 4: Fault indicator on the sender

## Receiver

OSSD LED (red)	ERR LED (red)	LED 1 2 3 4 (blue)	Possible cause	Rectification
●	☉	☉○○○	An internal fault has occurred.	Switch off the power supply and on again. If the fault persists, replace the receiver, see <a href="#">"Ordering information"</a> , Page 52.
●	☉	○☉○○	Fault in the supply voltage	Check the voltage supply and power supply, see <a href="#">"Technical data"</a> , Page 47. Switch off the power supply and on again. If the fault persists, replace the defective components, see <a href="#">"Ordering information"</a> , Page 52.
●	☉	○○☉○	The receiver has recognized beams from several senders.	Check the distance to senders of the same type. Make sure that beams from another sender cannot hit the receiver, see <a href="#">"Protection against interference from systems in close proximity to each other"</a> , Page 20. Switch off the power supply and on again.
●	☉	○○○☉	A fault or unexpected state was identified on the OSSDs of the system connection (e. g. over voltage, short-circuit to HIGH or short-circuit to LOW, cross-circuit, permissible load capacity exceeded)	Check the system wiring for a fault. Make sure that the OSSDs have been wired correctly, see <a href="#">"Integration in electrical control"</a> , Page 20. Switch off the power supply and on again. If the fault persists, replace the defective components, see <a href="#">"Ordering information"</a> , Page 52.

Table 5: Fault indicator on the receiver

### 11 Decommissioning

#### 11.1 Protection of the environment

The safety light curtain has been designed to minimize its impact on the environment. It uses only minimum of power and natural resources.

- ▶ At work, always act in an environmentally responsible manner. For this reason, please note the following information on disposal.

#### 11.2 Disposal

Always dispose of serviceableness devices in compliance with local/national rules and regulations with respect to waste disposal.



#### NOTE

We would be pleased to be of assistance on the disposal of this device. Contact us.

---

## 12 Technical data

### 12.1 Data sheet

#### General system data

	Minimum	Typical	Maximum
Protective field height, depending on type	300 mm to 2100 mm, 150 mm steps		
Resolution (detection capability), depending on the type	14 mm or 30 mm		
Protective field range <sup>1)</sup>			
Resolution 14 mm	0 ... 7 m	0 ... 8 m	
Resolution 30 mm	0 ... 10 m	0 ... 12 m	
Protection class (EN 50178) <sup>2)</sup>	III		
Enclosure rating (EN 60529)	IP 65 IP 67		
Supply voltage $V_s$ on the device <sup>3) 4)</sup>	19.2 V	24 V	28.8 V
Residual ripple <sup>5)</sup>			±10%
Synchronization	Optical		
Model name (EN 61496-1)	Type 2		
Category (EN ISO 13849-1)	Category 2		
Performance level <sup>6)</sup> (EN ISO 13849-1)	PL c		
Safety Integrity Level <sup>6)</sup>	SIL1 (IEC 61508)		
SIL claim limit <sup>6)</sup>	SILCL1 (EN 62061)		
PFHd (mean probability of a dangerous failure per hour)	$3.1 \times 10^{-8}$		
$T_M$ (Mission Time)	20 years (EN ISO 13849-1)		
Safe state when a fault occurs	At least one OSSD is in the LOW state		
Power-up delay of sender and receiver before ready			2 s

Table 6: General system data

- 1) At a typical scanning range, there is a possibility that all four LEDs to indicate alignment quality do not light up even when alignment is good.
- 2) Safety extra-low voltage SELV/PELV
- 3) The external voltage supply must be capable of buffering brief power failures of 20 ms as specified in EN 60204-1. Suitable power supplies are available as accessories from SICK.
- 4) A fuse with max. 2A must be placed in the isolated 24V DC circuit of the device to limit the available power.
- 5) Within the limits of  $U_y$
- 6) For more detailed information on the exact configuration of your machine, please consult your respective SICK subsidiary.

Sender	Minimum	Typical	Maximum
Wavelength of sender		Near-infrared (NIR) - invisible	
Weight	Depending on the protective field height see "Table of weights", Page 50		

Table 7: Technical specifications, sender

Receiver	Minimum	Typical	Maximum
<b>Output signal switching devices (OSSDs)</b>	2 PNP semiconductors, short-circuit protected <sup>1)</sup> , cross-circuit monitored		
Response time	see "Response time", Page 49		
Power-down time	100 ms		
Power-up delay		3 × response time	
Switching voltage <sup>2)</sup> HIGH (U <sub>rms</sub> )	U <sub>V</sub> -2.25 V	24 V	U <sub>V</sub>
Switching voltage LOW <sup>2) 3)</sup>	0 V	0 V	2.0 V
Current-carrying capacity of the OSSDs			300 mA ea.
Load capacity			30 nF
Load inductance			2.2 h
<b>Test pulse data <sup>4)</sup></b>			
Test pulse range		300 μs	350 μs
Test pulse rate	3 <sup>1</sup> /s	5 <sup>1</sup> /s	10 <sup>1</sup> /s
<b>Permissible conductor resistance</b>			
between device and load <sup>5)</sup>			2,5 Ω
Supply cable <sup>6)</sup>			1 Ω

Table 8: Technical specifications, receiver

- 1) Applies to the voltage range between -30 V and +30 V.
- 2) Acc. IEC 61 131-2
- 3) The specified values are the switching voltage passed to the safety light curtain. If higher voltages are impressed from the outside, the maximum value of 2.0 V can be exceeded.
- 4) When active, the outputs are tested cyclically (brief LOW). When selecting the downstream controllers, make sure that the test signals do not result in deactivation when using the above parameters.
- 5) Make sure to limit the individual conductor resistance to the downstream controller to this value to ensure that a cross-circuit between the outputs is safely detected. (Also note EN 60204 Electrical Machine Equipment, Part 1: General Requirements.)
- 6) The supply cable must not be used to connect other loads with the exception of the sender.



**Operating data**

	Minimum	Typical	Maximum
Connection	M12, 5-pin		
Length of cable <sup>1)</sup> e.g. wire cross-section 0.34 mm <sup>2</sup> , copper cable e.g. wire cross-section 0.5 mm <sup>2</sup> , cop- per cable			50 m 15 m  30 m
Ambient operating temperature <sup>2) 3)</sup>	-30 °C		+55 °C
Air humidity (non-condensing)	15 %		95 %
Storage temperature	-30 °C		+70 °C
Housing cross section	31 mm × 34 mm plus bracket <a href="#">see "Dimensional draw-ings", Page 51</a>		
Vibration resistance <sup>4)</sup>	5 g, 10–55 Hz (EN 60068-2-6)		
Shock resistance <sup>5)</sup>	10 g, 16 ms (EN 60068-2-29)		

Table 9: Operating data

- 1) Maximum permissible conductor resistances must be observed.
- 2) The temperature difference between sender and receiver must not exceed 25 K.
- 3) The cable belonging to the device incl. the associated connection plug must not be flexibly mounted under -25 °C.
- 4) Test conditions per axis: 1 octave/minute, amplitude: 0.35 mm, 20 sweeps
- 5) Test conditions per axis: 500 shocks

## 12.2 Response time

The response time depends on the resolution and protective field height of the system. The safety light curtain is available with the resolution of 14 mm or 30 mm.

Protective field height [mm]	Response time [ms]	
	Resolution 14 mm	Resolution 30 mm
300	11	10
450	12	10
600	13	10
750	13	11
900	14	11
1050	15	11
1200	16	12
1350	17	12
1500	18	13
1650	19	13
1800	20	13
1950	21	14
2100	22	14

Table 10: Response time dependent on the protective field height

### 12.3 power consumption

Protective field height [mm]	Typical power consumption, sender [W]		Typical power consumption, receiver [W] <sup>1)</sup>	
	Resolution 14 mm	Resolution 30 mm	Resolution 14 mm	Resolution 30 mm
300	0,96	0,82	1,92	1,63
450	1,08	0,86	2,16	1,73
600	1,20	0,91	2,40	1,82
750	1,32	0,96	2,64	1,92
900	1,44	1,01	2,88	2,02
1050	1,56	1,06	3,12	2,11
1200	1,68	1,10	3,36	2,21
1350	1,80	1,15	3,60	2,30
1500	1,92	1,20	3,84	2,40
1650	2,04	1,25	4,08	2,50
1800	2,16	1,30	4,32	2,59
1950	2,28	1,34	4,56	2,69
2100	2,40	1,39	4,80	2,78

Table 11: Power consumption, sender and receiver

<sup>1)</sup> Power discharged again via the OSSDs depending on the connected OSSD load must be added to the table values.

### 12.4 Table of weights

Protective field height [mm]	Weight [g] <sup>1)</sup>	
	Sender	Receiver
300	290	300
450	430	440
600	570	580
750	700	710
900	840	850
1050	970	980
1200	1110	1120
1350	1240	1250
1500	1380	1390
1650	1510	1520
1800	1650	1660
1950	1790	1800
2100	1920	1930

Table 12: Weight of sender and receiver

<sup>1)</sup> Tolerance: ± 50g

### 12.5 Dimensional drawings

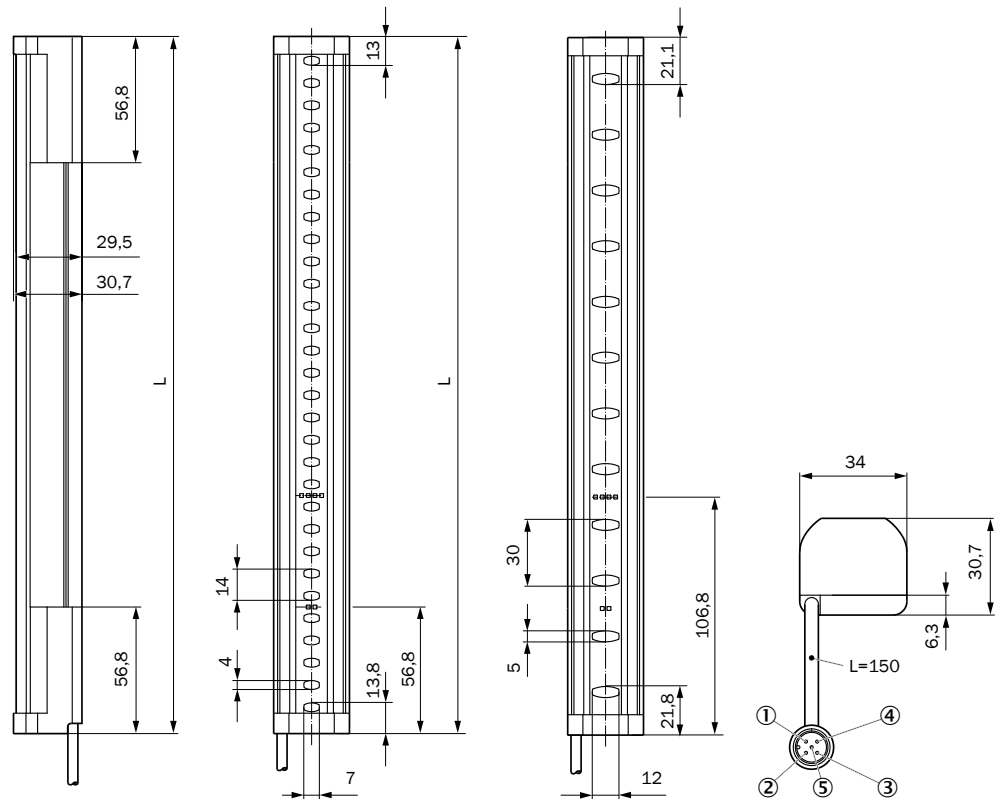

Figure 31: Dimensional drawing, sender and receiver

Protective field height, nominal [mm]	Protective field, effective = dimension L [mm] <sup>1</sup>
300	313
450	463
600	613
750	763
900	913
1050	1063
1200	1213
1350	1362
1500	1512
1650	1662
1800	1812
1950	1962
2100	2112

Table 13: Dimensions based on the protective field height, sender and receiver

<sup>1</sup> The effective protective field corresponds to the entire length of the housing. The test object defined in the standard IEC 61496-1 is recognized over the entire length of the housing. The limits of the protective field are identical to ends of the housing.

## 13 Ordering information

### 13.1 Scope of delivery

- Items supplied, sender**
- Sender
  - 2 ea. QuickFix bracket

- Items supplied, receiver**
- Receiver
  - 2 ea. QuickFix bracket
  - Test rod with diameter corresponding to the resolution of the safety light curtain
  - Label "Important Information"
  - Operating instructions on CD-ROM 2066639

### 13.2 Ordering information deTec2 Core

Protective field height [mm]	Ordering information deTec2 Core, resolution 14 mm <sup>1)</sup>			
	☛ Sender		☛ Receiver	
	Part number	Type code	Part number	Type code
300	1213163	C2C-SA03010A10000	1213188	C2C-EA03010A10000
450	1213189	C2C-SA04510A10000	1213190	C2C-EA04510A10000
600	1213191	C2C-SA06010A10000	1213192	C2C-EA06010A10000
750	1213193	C2C-SA07510A10000	1213194	C2C-EA07510A10000
900	1213195	C2C-SA09010A10000	1213196	C2C-EA09010A10000
1050	1213197	C2C-SA10510A10000	1213198	C2C-EA10510A10000
1200	1213183	C2C-SA12010A10000	1213199	C2C-EA12010A10000

Table 14: Ordering information deTec2 Core, resolution 14 mm

<sup>1)</sup> For other protective fields up to 2100 mm, contact your SICK subsidiary.

Protective field height [mm]	Ordering information deTec2 Core, resolution 30 mm			
	☛ Sender		☛ Receiver	
	Part number	Type code	Part number	Type code
300	1213200	C2C-SA03030A10000	1213184	C2C-EA03030A10000
450	1213202	C2C-SA04530A10000	1213203	C2C-EA04530A10000
600	1213204	C2C-SA06030A10000	1213205	C2C-EA06030A10000
750	1213206	C2C-SA07530A10000	1213207	C2C-EA07530A10000
900	1213208	C2C-SA09030A10000	1213209	C2C-EA09030A10000
1050	1213210	C2C-SA10530A10000	1213211	C2C-EA10530A10000
1200	1213212	C2C-SA12030A10000	1213213	C2C-EA12030A10000
1350	1213214	C2C-SA13530A10000	1213215	C2C-EA13530A10000
1500	1213216	C2C-SA15030A10000	1213217	C2C-EA15030A10000
1650	1213218	C2C-SA16530A10000	1213219	C2C-EA16530A10000
1800	1213220	C2C-SA18030A10000	1213221	C2C-EA18030A10000
1950	1213222	C2C-SA19530A10000	1213223	C2C-EA19530A10000
2100	1213201	C2C-SA21030A10000	1213164	C2C-EA21030A10000

Table 15: Ordering information deTec2 Core, resolution 30 mm

## 14 Accessories

### 14.1 Ordering information, accessories

#### Connectors

Part	Part number
<b>Connecting cable<sup>1)</sup> M12, 5-pin (0.34 mm<sup>2</sup>)</b>	
DOL-1205-G02MC socket straight with 2m cable, open end	6025906
DOL-1205-G05MC socket straight with 5m cable, open end	6025907
DOL-1205-G10MC socket straight with 10m cable, open end	6025908
DOL-1205-G20MC socket straight with 20m cable, open end	6050247
DOL-1205-G30MC socket straight with 30m cable, open end	6050248
DOL-1205-G02MC socket angled with 2m cable, open end	6025909
DOL-1205-G05MC socket angled with 5m cable, open end	6025910
DOL-1205-G10MC socket angled with 10m cable, open end	6025911
<b>Connection cable</b>	
DSL-1285GM25034KM1, connection cable, M12, 5-pin on M12, 8-pin	2070987
DSL-6187GM25034KM1, connection cable, M12, 5-pin on M26, 7-pin	2070988
DSL-6182GM25034KM1, connection cable, M12, 5-pin on M26, 12-pin	2070989
<b>Distribution list</b>	
DSC-1205T000025KM0, T distributor	6030664
<b>Terminal with resistance</b>	
Terminal with resistance, 2.15 k $\Omega$	2073807
<b>Power supplies</b>	
Output 24 V DC, 50 W (2,1 A), power supply NEC Class 2, SELV, PELV, input 120–240 V AC (PS50WE24V)	7028789
Output 24 V DC, 95 W (3,9 A), power supply NEC Class 2, SELV, PELV, input 100–120/220–240 V AC (PS95WE24V)	7028790

<sup>1)</sup> Ambient operating temperature: Up to -30 °C with fixed installation

#### Alignment aid

Part	Part number
Laser alignment aid AR60	1015741
Adapter	4070854

#### Cleaning agent

Part	Part number
Anti-static plastic cleaner	5600006
SICK lens cloth	4003353

**Bracket**

Part	Part number
BEF-3SHABPKU2, 2 ea. QuickFix bracket (included with delivery)	2066048
BEF-1SHABPKU4, 4 ea. FlexFix bracket	2066614
BEF-1SHAABBKU2, FlexFix bracket kit (2 x FlexFix bracket, 4 sliding nuts, 4 screws, 4 washers)	2073543
BEF-1SHABP004, replacement bracket (kit with 4 brackets)	2071021

**QuickFix bracket**

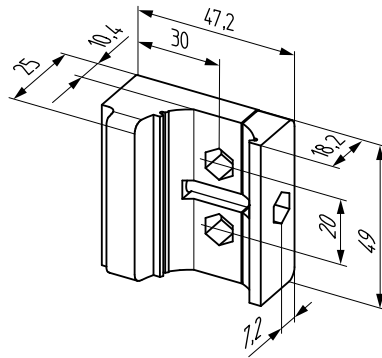

Figure 32: Dimensional drawing of the QuickFix bracket (2066048)

**FlexFix bracket**

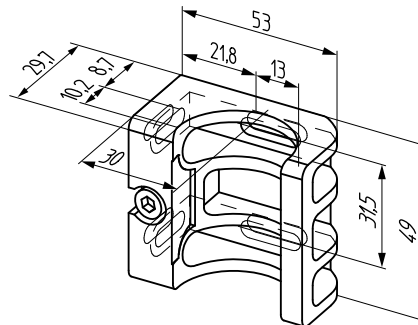

Figure 33: Dimensional drawing of the FlexFix bracket (2066614)

Replacement bracket

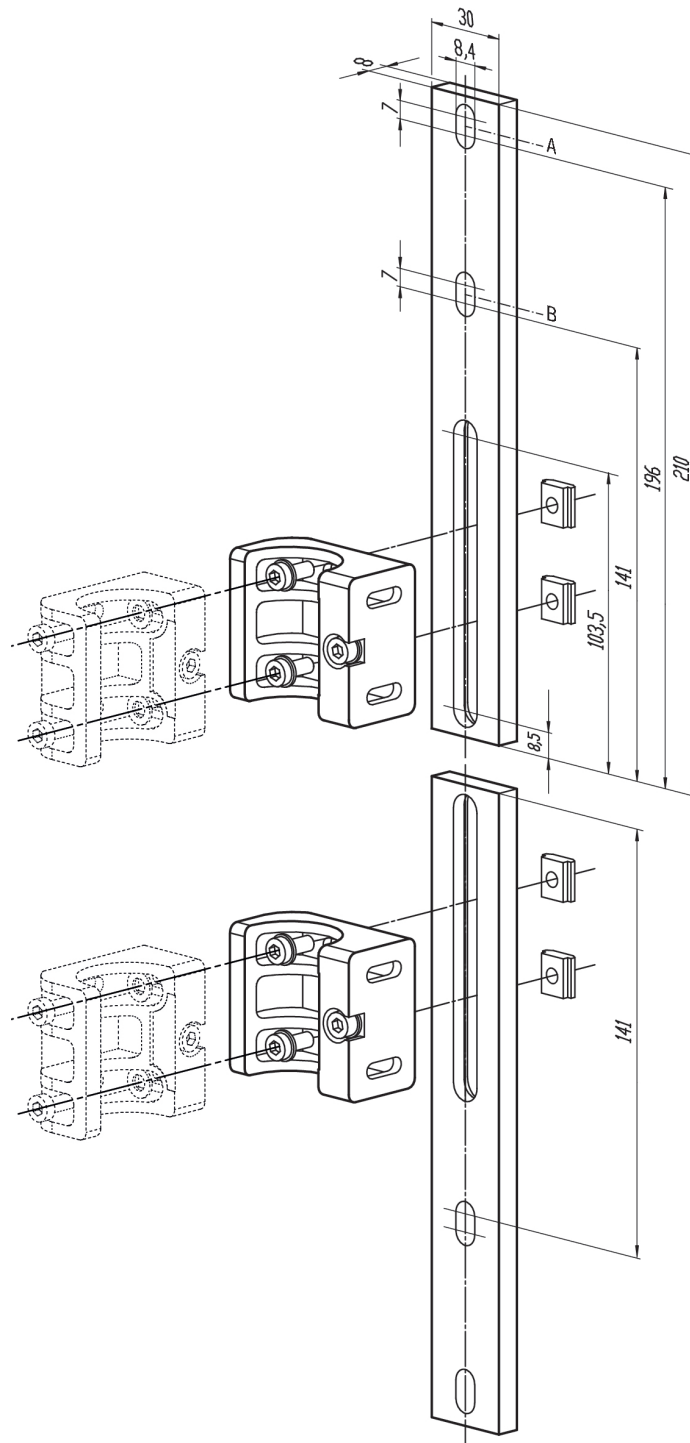

Figure 34: Dimensional drawing of the replacement bracket (2071021)

14.2 Weld spark guard

**Function and use** The weld spark guard can be used to protect the front screen of the safety light curtain. The weld spark guard reduces the scanning range of the system by 15 %.

Ordering information

Part	Part number
Weld spark guard	2069268

Mounting

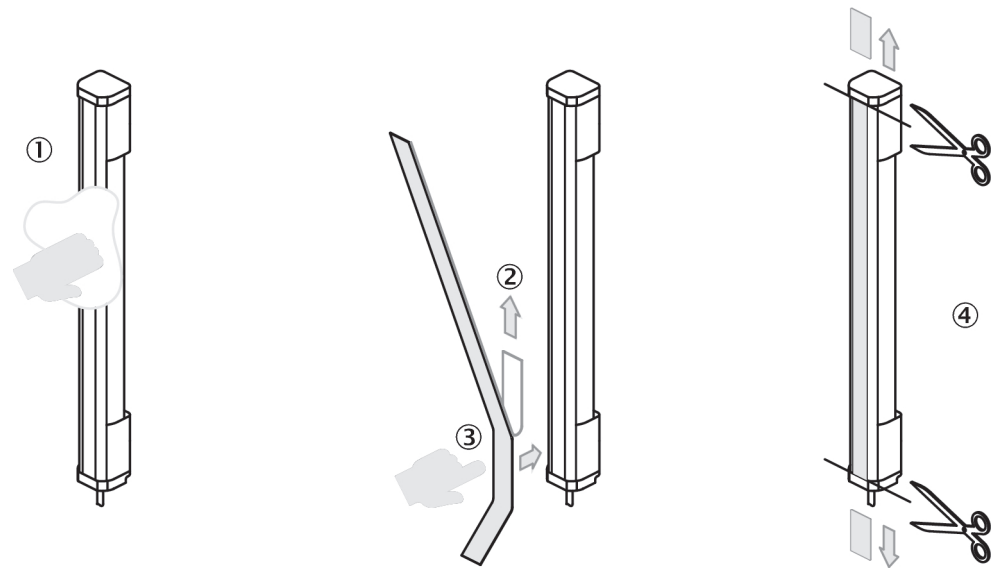

Figure 35: Mounting the weld spark guard

- ① Clean the front screen.
- ② Remove the carrier film
- ③ Mount the weld spark guard
- ④ Crop the excess length at the ends

### 14.3 Deflector mirror

**Function and use** Deflector mirrors can be used to shape the protective field to secure hazardous points from multiple sides using a single safety light curtain.



**DANGER**

Risk of ineffectiveness of the protective device

Persons and parts of the body to be protected are not recognized in case of non-observance.

- ▶ Only mount deflector mirrors to solid walls or machine components. The position of the deflector mirrors must not change after alignment.
- ▶ Do not use deflector mirrors if contamination, beading water, condensation or frost on the deflector mirrors is to be expected.
- ▶ Make sure that the deflector mirrors are free of contamination, beading water, condensation or frost at all times.



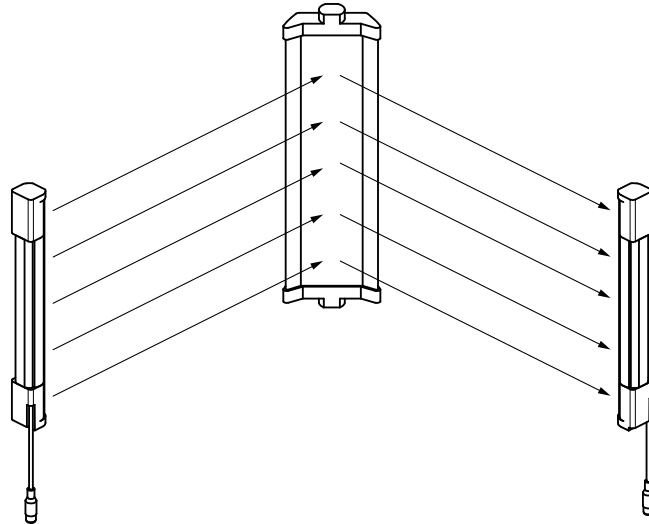

Figure 36: Example of use of deflector mirrors

### 14.3.1 Mounting

To mount the deflector mirrors, use the included swivel mount brackets.

### 14.3.2 Change in scanning range using deflector mirrors



#### NOTE

The use of deflector mirrors reduces the scanning range depending on the number of deflector mirrors in the protective field.

The information relates to 90° beam deflection per mirror and a protective field height of 900 mm.

Model name	Resolution	Scanning range, typical <sup>1)</sup>	Scanning range with 1 deflector mirror, typical <sup>1)</sup>	Scanning range with 2 deflector mirrors, typical <sup>1)</sup>
PNS75, PNS125	14 mm	8 m	7.2 m	6.4 m
PNS75, PNS125	30 mm	12 m	10.7 m	9.6 m

Table 16: Scanning range with and without 1 or 2 deflector mirrors

<sup>1)</sup> At a typical scanning range, there is a possibility that all four LEDs to indicate alignment quality do not light up even when alignment is good.

### 14.3.3 Deflector mirror PNS75 - ordering information

Mirror height S [mm]	Protective field height [mm]	Type number	Part number
340	300	PNS75-034	1019414
490	450	PNS75-049	1019415
640	600	PNS75-064	1019416
790	750	PNS75-079	1019417
940	900	PNS75-094	1019418
1090	1050	PNS75-109	1019419
1240	1200	PNS75-124	1019420

Table 17: Ordering information, deflector mirror PNS75

Mirror height S [mm]	Protective field height [mm]	Type number	Part number
1390	1350	PNS75-139	1019421
1540	1500	PNS75-154	1019422
1690	1650	PNS75-169	1019423
1840	1800	PNS75-184	1019424

Table 17: Ordering information, deflector mirror PNS75

14.3.4 Deflector mirror PSN125 - ordering information

Mirror height S [mm]	Protective field height [mm]	Type number	Part number
340	300	PNS125-034	1019425
490	450	PNS125-049	1019426
640	600	PNS125-064	1019427
790	750	PNS125-079	1019428
940	900	PNS125-094	1019429
1090	1050	PNS125-109	1019430
1240	1200	PNS125-124	1019431
1390	1350	PNS125-139	1019432
1540	1500	PNS125-154	1019433
1690	1650	PNS125-169	1019434
1840	1800	PNS125-184	1019435

Table 18: Ordering information, deflector mirror PSN125

14.4 Columns

Part	Part number
<b>Device columns</b>	
Column height 985 mm	2045490
Column height 1165 mm	2045641
Column height 1265 mm	2045642
Column height 1720 mm	2045643
Column height 2020 mm	2045644
Column height 2250 mm	2045645
Column height 2400 mm	2045646
<b>Mirror columns</b>	
Column height 1285 mm, mirror height 900 mm	1043453
Column height 1720 mm, mirror height 1350 mm	1043454
Column height 2000 mm, mirror height 1650 mm	1043455
Column height 2200 mm, mirror height 1800 mm	1043456

Table 19: Ordering information, columns

## 14.5 Test rods

Part	Part number
Test rod 14 mm	2022599
Test rod 30 mm	2022602
Test rod holder	2052249

Table 20: Ordering information, test rods

15 List of figures

Fig. 1. Sender and receiver..... 10

Fig. 2. Sender indicators..... 11

Fig. 3. Receiver indicators..... 12

Fig. 4. Hazardous point protection..... 13

Fig. 5. Access protection..... 13

Fig. 6. Hazardous area protection..... 14

Fig. 7. Minimum distance to hazardous point for orthogonal approach to protective field..... 17

Fig. 8. Representation of the accessibility of ESPE by reaching over. Left: Protective field that cannot be reached over. Right: Protective field that can be reached over..... 18

Fig. 9. Minimum distance to reflective surfaces..... 19

Fig. 10. Graph, minimum distance from reflective surfaces..... 19

Fig. 11. The direction of transmission of systems in close proximity to each other is reversed. The sender of the 2nd system is not affected by the beams 1st system..... 20

Fig. 12. Dual-channel and isolated connection of OSSD1 and OSSD2..... 21

Fig. 13. No potential difference between load and protective device..... 21

Fig. 14. Schematic representation of operation with restart interlock..... 22

Fig. 15. Connection diagram for UE48-2OS with restart interlock and external device monitoring..... 23

Fig. 16. Sender and receiver must not be installed at 180° rotated relative to each other..... 25

Fig. 17. Mount QuickFix bracket to a profile ..... 27

Fig. 18. Mount FlexFix bracket to a profile frame..... 28

Fig. 19. Inserting the safety light curtain in the FlexFix brackets..... 29

Fig. 20. Mount FlexFix bracket to a device column (accessory)..... 30

Fig. 21. Replacement bracket, installation version A..... 31

Fig. 22. Replacement bracket, installation version B..... 31

Fig. 23. Replacement bracket, installation version C..... 32

Fig. 24. Connection of OSSD1 and OSSD2..... 33

Fig. 25. No potential difference between load and protective device ..... 34

Fig. 26. Sender and receiver..... 34

Fig. 27. QuickFix bracket: adjust vertically..... 36

Fig. 28. FlexFix bracket: adjust vertically / rotate..... 37

Fig. 29. Daily checks of the protective device: Step 1..... 40

Fig. 30. Daily checks of the protective device: Step 2..... 41

Fig. 31. Dimensional drawing, sender and receiver..... 51

Fig. 32. Dimensional drawing of the QuickFix bracket (2066048)..... 54

Fig. 33. Dimensional drawing of the FlexFix bracket (2066614)..... 54

Fig. 34. Dimensional drawing of the replacement bracket (2071021)..... 55

Fig. 35. Mounting the weld spark guard..... 56

Fig. 36. Example of use of deflector mirrors..... 57

## 16 List of tables

Tab. 1.	Formula for calculating the minimum distance from reflective surfaces.....	19
Tab. 2.	Device connection pin assignment (M12, 5-pin).....	34
Tab. 3.	Blue LEDs to indicate the alignment quality.....	37
Tab. 4.	Fault indicator on the sender.....	44
Tab. 5.	Fault indicator on the receiver.....	45
Tab. 6.	General system data.....	47
Tab. 7.	Technical specifications, sender.....	48
Tab. 8.	Technical specifications, receiver.....	48
Tab. 9.	Operating data.....	49
Tab. 10.	Response time dependent on the protective field height.....	49
Tab. 11.	Power consumption, sender and receiver.....	50
Tab. 12.	Weight of sender and receiver .....	50
Tab. 13.	Dimensions based on the protective field height, sender and receiver.....	51
Tab. 14.	Ordering information deTec2 Core, resolution 14 mm.....	52
Tab. 15.	Ordering information deTec2 Core, resolution 30 mm.....	52
Tab. 16.	Scanning range with and without 1 or 2 deflector mirrors.....	57
Tab. 17.	Ordering information, deflector mirror PNS75.....	57
Tab. 18.	Ordering information, deflector mirror PSN125.....	58
Tab. 19.	Ordering information, columns.....	58
Tab. 20.	Ordering information, test rods.....	59

## 17 Appendix

## 17.1 Compliance with EC directives

## EC Declaration of Conformity, page 1

**SICK**

TYPE: deTec2	Ident-No.: 9200754
--------------	--------------------

<b>EC declaration of conformity</b>	en
The undersigned, representing the following manufacturer herewith declares that the product is in conformity with the provisions of the following EC directive(s) (including all applicable amendments), and that the respective standards and/or technical specifications have been applied.	
<b>EU-Konformitätserklärung</b>	de
Der Unterzeichner, der den nachstehenden Hersteller vertritt, erklärt hiermit, dass das Produkt in Übereinstimmung mit den Bestimmungen der nachstehenden EU-Richtlinie(n) (einschließlich aller zutreffenden Änderungen) ist, und dass die entsprechenden Normen und/oder technischen Spezifikationen zur Anwendung gelangt sind.	
<b>EO декларация за съответствие</b>	bg
Подписалият, който представя долупоменатия производител, обявява, че продуктът съответва на разпоредбите на долуизброените директиви на ЕО (включително на всички действащи изменения) и че отговаря на съответните норми и/или технически спецификации за приложение.	
<b>ES prohlášení o shodě</b>	cs
Niže podepsaný, zastupující následujícího výrobce, tímto prohlašuje, že výrobek je v souladu s ustanoveními následující(ch) směrnice (směrnic) ES (včetně všech platných změn) a že byly použity odpovídající normy a/nebo technické specifikace.	
<b>EF-overensstemmelseserklæring</b>	da
Undertegnede, der repræsenterer følgende producent erklærer hermed at produktet er i overens-stemmelse med bestemmelserne i følgende EF-direktiv(er) (inklusive alle gældende ændringer) og at alle tilsvarende standarder og/eller tekniske specifikationer er blevet anvendt.	
<b>ΕΕ-Δήλωση συμμόρφωσης</b>	el
Ο Υπογράφων, εκπροσωπών τον ακόλουθο κατασκευαστή δηλώνει με το παρόν έγγραφο ότι το προϊόν συμμορφώνεται με τους όρους της (των) ακόλουθης (-ών) Οδηγίας (-ών) της ΕΕ (συμπεριλαμβανομένων όλων των εφαρμοζόμενων τροποποιήσεων) και ότι έχουν εφαρμοστεί τα αντίστοιχα πρότυπα και/ή οι τεχνικές προδιαγραφές.	
<b>Declaración de conformidad CE</b>	es
El abajo firmante, en representación del fabricante indicado a continuación, declara que el producto es conforme con las disposiciones de la(s) siguiente(s) directiva(s) de la CE (incluyendo todas las modificaciones aplicables) y que las respectivas normas y/o especificaciones técnicas han sido aplicadas.	
<b>EÜ vastavusdeklaratsioon</b>	et
Allakirjutanu, kes esindab järgmist tootjat, kinnitab käesolevaga, et antud toode vastab järgneva(te) EÜ direktiivi(de) sätetele (kaasa arvatud kõikidele asjakohastele muudatustele) ja et on kohaldatud vastavaid nõudeid ja/lõi tehnilisi kirjeldusi.	
<b>EY-vaatimustenmukaisuusvakuutus</b>	fi
Allekirjoittanut, joka edustaa alla mainittua valmistajaa, vakuuttaa täten, että tuote on seuraavan (-ien) EU-direktiivin (-ien) vaatimusten mukainen (mukaan lukien kaikki sovellettavat muutokset) ja että vastaavia standardeja ja teknisiä erittelyjä on sovellettu.	
<b>Déclaration CE de conformité</b>	fr
Le soussigné, représentant le constructeur ci-après, déclare par la présente que le produit est conforme aux exigences de la (des) directive(s) CE suivantes (y compris tous les amendements applicables) et que les normes et/ou spécifications techniques correspondantes ont été appliquées.	
<b>EK megfeleléségi nyilatkozat</b>	hu
Alulírott, az alábbi gyártó képviselőtében ezennel kijelenti, hogy a termék megfelel az alábbi EK-irányelv(ek) követelményeinek (beleértve azok minden vonatkozó módosítását) és kijelenti hogy a megfelelő szabványokat és/vagy műszaki előírásokat alkalmazta.	
<b>EB-samræmisfyrirlýsing</b>	is
Undirritaður, fyrir hönd framleiðandans sem nefndur er hér að neðan, lýsir því hér með yfir að varan er í samræmi við ákvæði eftirtalinnna EB-tilskipana (að meðtöldum öllum breytingum sem við eiga) og að varan er í samræmi við viðeigandi staðla og/eða tækniforskriftir.	
<b>Dichiarazione CE di conformità</b>	it
Il sottoscritto, rappresentante il seguente costruttore dichiara qui di seguito che il prodotto risulta in conformità a quanto previsto dalla(e) seguente(i) direttiva(e) comunitaria(e) (comprese tutte le modifiche applicabili) e che sono state applicate tutte le relative norme e/o specifiche tecniche.	
<b>EB atitikties deklaracija</b>	lt
Pasirašiusysis, atstovaujantis šiam gamintojui deklaruoja, kad gaminys atitinka šios (-ių) EB direktyvos (-ų) reikalavimus (įskaitant visus taikytinus keitinius) ir kad buvo taikomi antrajame puslapyje nurodyti standartai ir (arba) techninės specifikacijos.	

**SICK**

<b>TYPE: deTec2</b>	Ident-No.: 9200754
---------------------	--------------------

<b>EK atbilstības deklarācija</b>	lv
Apakšā parakstījies persona, kas pārstāv zemāk minēto ražotāju ar šo deklarē, ka izstrādājums atbilst zemāk minētajai (-ām) EK direktīvai (-ām) (ieskaitot visus atbilstošos grozījumus) un ka izstrādājumam ir piemēroti attiecīgie standarti un/vai tehniskās specifikācijas.	
<b>EG-verklaring van overeenstemming</b>	nl
Ondergetekende, vertegenwoordiger van de volgende fabrikant, verklaart hiermee dat het product voldoet aan de bepalingen van de volgende EG-richtlijn(en) (inclusief alle van toepassing zijnde wijzigingen) en dat de overeenkomstige normen en/of technische specificaties zijn toegepast.	
<b>EF-samsvarserklæring</b>	no
Undertegnede, som representerer nedennævnte produsent, erklærer herved at produktet er i samsvar med bestemmelsene i følgende EU-direktiv(er) (inkludert alle relevante endringer) og at relevante normer og/eller tekniske spesifikasjoner er blitt anvendt.	
<b>Deklaracja zgodności WE</b>	pl
Niżej podpisany, reprezentujący następującego producenta niniejszym oświadczam, że wyrób jest zgodny z postanowieniami następujących dyrektyw WE (wraz z odpowiednimi poprawkami) oraz, że zastosowano odpowiednie normy i/lub specyfikacje techniczne.	
<b>Declaração CE de conformidade</b>	pt
O abaixo assinado, que representa o seguinte fabricante, declara deste modo que o produto está em conformidade com as disposições da(s) seguinte(s) directiva(s) CE (incluindo todas as alterações aplicáveis) e que foram aplicadas as respectivas normas e/ou especificações técnicas.	
<b>Declaratie de conformitate CE</b>	ro
Semnatarul, în calitate de reprezentant al producătorului numit mai jos, declară prin prezenta că produsul este în conformitate cu prevederile directivelor CE enumerate mai jos (inclusiv cu toate modificările aferente) și că s-au îndeplinit normele și/sau specificațiile tehnice corespunzătoare.	
<b>ES vyhlášení o zhode</b>	sk
Dolu podpísaný zástupca výrobcu týmto vyhlasuje, že výrobok je v súlade s ustanoveniami nasledujúcej (nasledujúcich) smernice (smerníc) ES (vrátane všetkých platných zmien) a že sa použili príslušné normy a/alebo technické špecifikácie.	
<b>Izjava ES o skladnosti</b>	sl
Podpisani predstavnik spodaj navedenega proizvajalca izjavljam, da je proizvod v skladu z določbami spodaj navedenih direktiv ES (vključno z vsemi ustreznimi spremembami) in da so bili uporabljeni ustrezni standardi in/ali tehnične specifikacije.	
<b>EG-försäkran om överensstämmelse</b>	sv
Undertecknad, som representerar nedanstående tillverkare, försäkras härmed att produkten överensstämmer med bestämmelserna i följande EU-direktiv (inklusive samtliga tillämpliga tillägg till dessa) och att relevanta standarder och/eller tekniska specifikationer har tillämpats.	
<b>AB-Uygunluk Beyanı</b>	tr
Aşağıdaki üreticiyi temsil eden imza sahibi böylelikle, ürünün aşağıdaki AB-Yönergesinin(lerin) direktifleri ile (tüm ilgili deęişiklikleri kapsayacak şekilde) uyumlu olduđunu ve ilgili normların ve/veya teknik spesifikasyonların uygulandıđını beyan eder.	

Directives used: MAS-DIRECTIVE 2006/42/EC  
EMC-DIRECTIVE 2004/108/EC

You can obtain the EC declaration of conformity with the standards used at: [www.sick.com](http://www.sick.com)

SICK AG  
Erwin-Sick-Straße 1  
D-79183 Waldkirch  
Germany

2014-01-14

Date

ppa Dr. Georg Plasberg  
Management Board  
(Industrial Safety Systems)  
authorized for technical documentation

ppa. Birgit Knobloch  
Division Manager Production  
(Industrial Safety Systems)

## 17.2 Checklist for initial commissioning and commissioning

### Checklist for manufacturers/installers installing electro-sensitive protective devices (ESPE)

The details on the items listed below must be available at the latest when the system is commissioned for the first time, depending, however, on the various applications the requirements of which must be reviewed by the manufacturer/installer.

This checklist should be retained and kept with the machine documentation to serve as reference during recurring tests.

This checklist does not replace the initial commissioning, nor the regular inspection by qualified safety personnel.

Have the safety rules and regulations been observed in compliance with the directives/standards applicable to the machine?	Yes <input type="checkbox"/> No <input type="checkbox"/>
Are the applied directives and standards listed in the declaration of conformity?	Yes <input type="checkbox"/> No <input type="checkbox"/>
Does protective device comply with the required PL/SILCL and PFHd in accordance with EN ISO 13849-1/EN 62061 and type acc. to EN 61496-1?	Yes <input type="checkbox"/> No <input type="checkbox"/>
Is the access to the hazardous area/hazardous point only possible through the protective field of the ESPE?	Yes <input type="checkbox"/> No <input type="checkbox"/>
Have appropriate measures been taken to prevent (mechanical point-of-operation guarding) or monitor unprotected presence in the hazardous area when protecting a hazardous area/hazardous point and have these been secured against removal?	Yes <input type="checkbox"/> No <input type="checkbox"/>
Are additional mechanical protective measures fitted and secured against manipulation which prevent reaching below, above or around the ESPE?	Yes <input type="checkbox"/> No <input type="checkbox"/>
Has the maximum shutdown and/or stopping time of the machine been measured, specified and documented (at the machine and/or in the machine documentation)?	Yes <input type="checkbox"/> No <input type="checkbox"/>
Has the ESPE been mounted such that the required minimum distance from the nearest hazardous point has been achieved?	Yes <input type="checkbox"/> No <input type="checkbox"/>
Are the ESPE devices properly mounted and secured against manipulation after adjustment?	Yes <input type="checkbox"/> No <input type="checkbox"/>
Are the required protective measures against electric shock in effect (protection class)?	Yes <input type="checkbox"/> No <input type="checkbox"/>
Is the control switch for resetting the protective devices (ESPE) or restarting the machine present and correctly installed?	Yes <input type="checkbox"/> No <input type="checkbox"/>
Are the outputs of the ESPE (OSSD) integrated according to required PL/SILCL compliant with EN ISO 13849-1/EN 62061 and does the integration correspond to the comply with the circuit diagrams?	Yes <input type="checkbox"/> No <input type="checkbox"/>
Has the protective function been checked in compliance with the test notes of this documentation?	Yes <input type="checkbox"/> No <input type="checkbox"/>
Are the given protective functions effective at every setting of the operating mode selector switch?	Yes <input type="checkbox"/> No <input type="checkbox"/>
Are the switching elements activated by the ESPE, e.g. contactors, valves, monitored?	Yes <input type="checkbox"/> No <input type="checkbox"/>
Is the ESPE effective over the entire period of the dangerous state?	Yes <input type="checkbox"/> No <input type="checkbox"/>
Once initiated, will a dangerous state be stopped when switching the ESPE on or off and when changing the operating mode, or when switching to another protective device?	Yes <input type="checkbox"/> No <input type="checkbox"/>
Has the "Important Information" label for the daily check been attached such that it is well visible for the operator?	Yes <input type="checkbox"/> No <input type="checkbox"/>









**Australia**

Phone +61 3 9457 0600  
1800 334 802 – tollfree  
E-Mail sales@sick.com.au

**Belgium/Luxembourg**

Phone +32 (0)2 466 55 66  
E-Mail info@sick.be

**Brasil**

Phone +55 11 3215-4900  
E-Mail sac@sick.com.br

**Canada**

Phone +1 905 771 14 44  
E-Mail information@sick.com

**Česká republika**

Phone +420 2 57 91 18 50  
E-Mail sick@sick.cz

**China**

Phone +86 4000 121 000  
E-Mail info.china@sick.net.cn  
Phone +852-2153 6300  
E-Mail ghk@sick.com.hk

**Danmark**

Phone +45 45 82 64 00  
E-Mail sick@sick.dk

**Deutschland**

Phone +49 211 5301-301  
E-Mail info@sick.de

**España**

Phone +34 93 480 31 00  
E-Mail info@sick.es

**France**

Phone +33 1 64 62 35 00  
E-Mail info@sick.fr

**Great Britain**

Phone +44 (0)1727 831121  
E-Mail info@sick.co.uk

**India**

Phone +91-22-4033 8333  
E-Mail info@sick-india.com

**Israel**

Phone +972-4-6881000  
E-Mail info@sick-sensors.com

**Italia**

Phone +39 02 27 43 41  
E-Mail info@sick.it

**Japan**

Phone +81 (0)3 3358 1341  
E-Mail support@sick.jp

**Magyarország**

Phone +36 1 371 2680  
E-Mail office@sick.hu

**Nederland**

Phone +31 (0)30 229 25 44  
E-Mail info@sick.nl

**Norge**

Phone +47 67 81 50 00  
E-Mail sick@sick.no

**Österreich**

Phone +43 (0)22 36 62 28 8-0  
E-Mail office@sick.at

**Polska**

Phone +48 22 837 40 50  
E-Mail info@sick.pl

**România**

Phone +40 356 171 120  
E-Mail office@sick.ro

**Russia**

Phone +7-495-775-05-30  
E-Mail info@sick.ru

**Schweiz**

Phone +41 41 619 29 39  
E-Mail contact@sick.ch

**Singapore**

Phone +65 6744 3732  
E-Mail sales.gsg@sick.com

**Slovenija**

Phone +386 (0)1-47 69 990  
E-Mail office@sick.si

**South Africa**

Phone +27 11 472 3733  
E-Mail info@sickautomation.co.za

**South Korea**

Phone +82 2 786 6321/4  
E-Mail info@sickkorea.net

**Suomi**

Phone +358-9-25 15 800  
E-Mail sick@sick.fi

**Sverige**

Phone +46 10 110 10 00  
E-Mail info@sick.se

**Taiwan**

Phone +886 2 2375-6288  
E-Mail sales@sick.com.tw

**Türkiye**

Phone +90 (216) 528 50 00  
E-Mail info@sick.com.tr

**United Arab Emirates**

Phone +971 (0) 4 88 65 878  
E-Mail info@sick.ae

**USA/México**

Phone +1(952) 941-6780  
1 (800) 325-7425 – tollfree  
E-Mail info@sickusa.com

More representatives and agencies  
at [www.sick.com](http://www.sick.com)