

4 3 2 1
 DRAWING MADE IN THIRD ANGLE PROJECTION
 THIS DRAWING IS UNPUBLISHED. RELEASED FOR PUBLICATION .19
 © COPYRIGHT 19 BY AMP INCORPORATED. ALL INTERNATIONAL RIGHTS RESERVED.

| LOC | DIST | REVISIONS | | | | |
|-----|------|-----------|-----|--------------------------|---------|-------|
| | | ZONE | LTR | DESCRIPTION | DATE | APPRO |
| G | 14 | | J | REVISED PER 0720-0230-93 | 2/25/94 | DAP |

METRIC
 DIMENSIONS LISTED IN mm [INCHES]

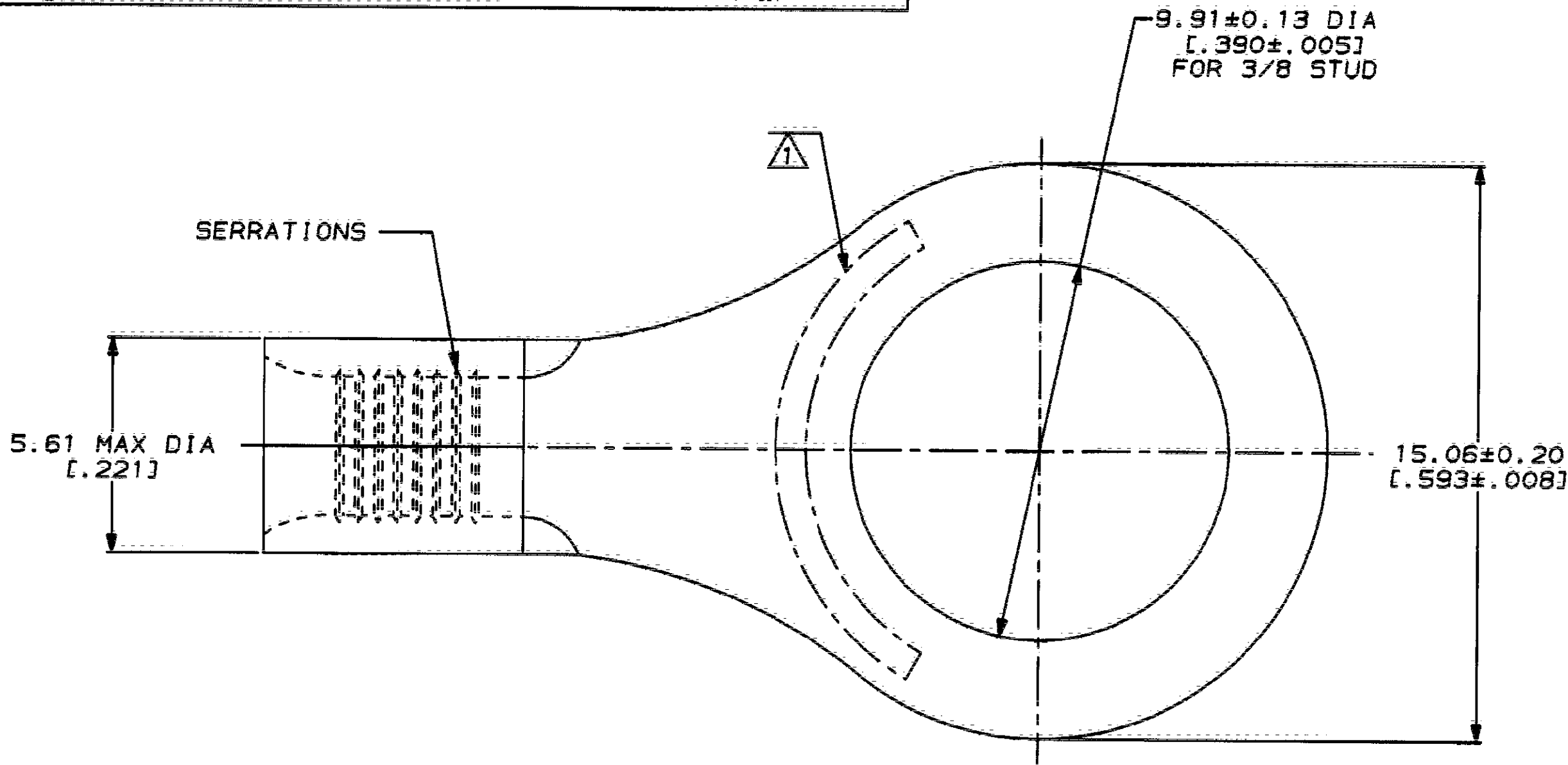

| | |
|----------------------------|----------------------------|
| AMP WIRE RANGE | UL E13288 Listed |
| 12-10 AWG STRANDED | 12-10 AWG STRANDED |
| LR7189 Certified | MILITARY P/N AND CLASS |
| NOT CERTIFIED | NOT APPLICABLE |

△ STAMP AMP 12-10* APPROX AS SHOWN

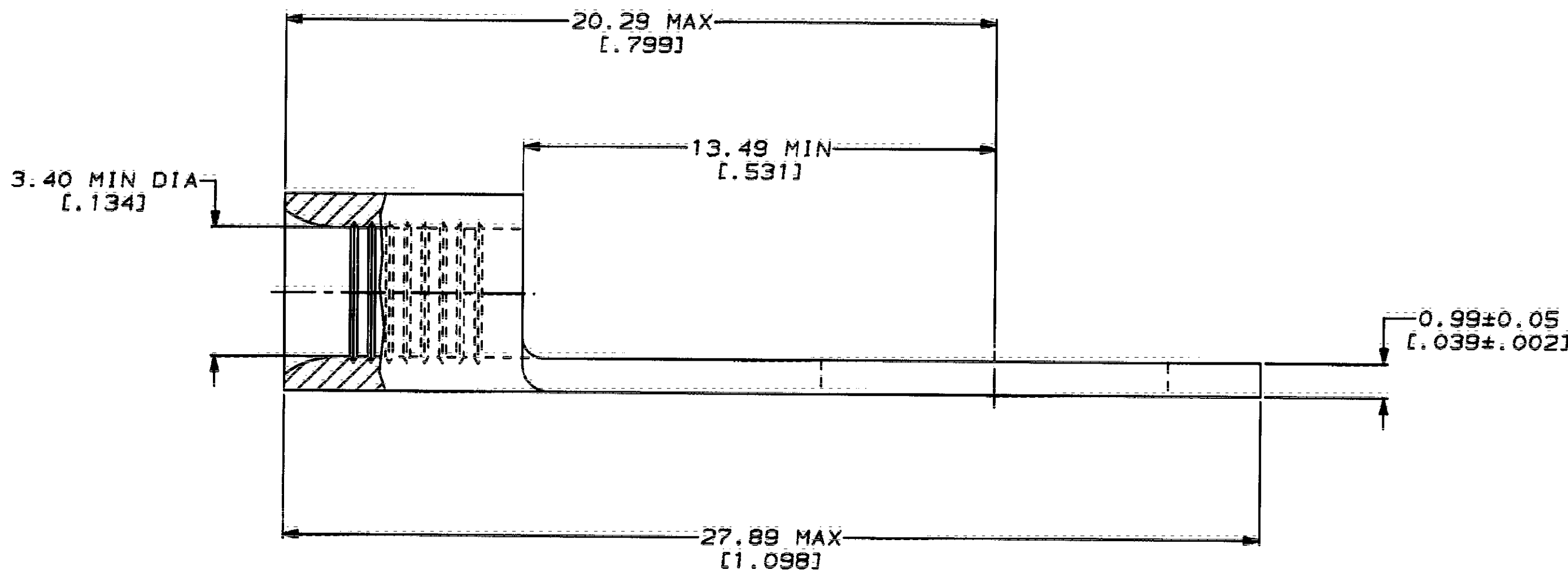

30972

PART NO

AMP INCORPORATED
CUSTOMER SERVICE SYSTEMS

MAX RECOMMENDED OPERATING
 TEMPERATURE:
 170°C MAX

DO NOT SCALE PRINT.
 UNLESS SPECIFIED
 DIMENSIONS IN mm [INCHES]
 TOLERANCES ON :
 2 PLC DEC ± -
 3 PLC DEC ± -
 ANGLES ± -

DR 2-9-93
 TA BRINKMAN

CHK 2-9-93
 DA PATTERSON

APPD 2-9-93
 DE MILLER

APPD 2-9-93
 JL HECKLEY

PRODUCT SPEC

APPLICATION SPEC

WEIGHT

AMP AMP Incorporated
 Harrisburg, PA 17105-3608

NAME
**TERMINAL, RING TONGUE,
 BUDGET**

VOLTAGE RATING:
 NOT APPLICABLE
 WIRE CROSS SECTIONAL AREA RANGE:
 2.62-6.64mm² [5,180-13,100] CIR MILS
 STRANDED

FINISH
 TIN PLATE
 0.00254[.000100] MIN
 THK PER MIL-T-10727

SIZE
 CAGE CODE
 DRAWING NO

SCALE 8:1
 00779
 C-30972
 SHEET 1 OF 1

THIS DRAWING IS A CONTROLLED DOCUMENT FOR
 AMP INCORPORATED. IT IS SUBJECT TO CHANGE
 AND THE CONTROLLING ENGINEERING ORGANIZATION
 SHOULD BE CONTACTED FOR THE LATEST REVISION.

Mouser Electronics

Authorized Distributor

Click to View Pricing, Inventory, Delivery & Lifecycle Information:

[TE Connectivity:](#)

[30972](#)