

5

4

3

2

1

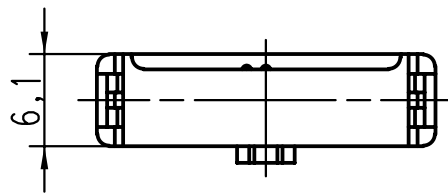
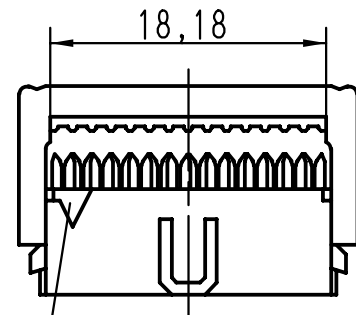
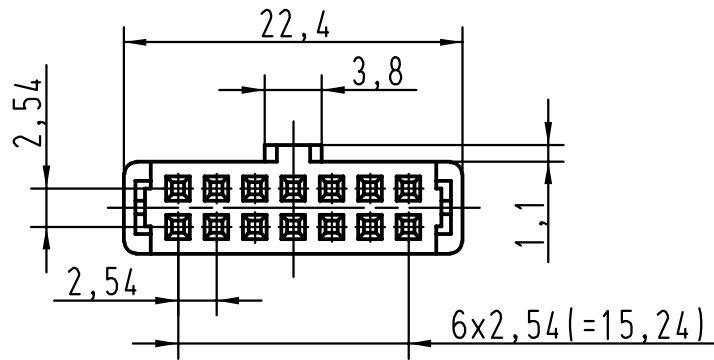

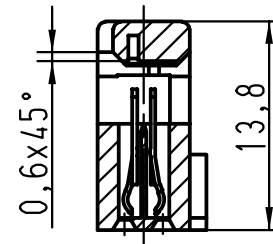

vorverrastet  
pre assembled

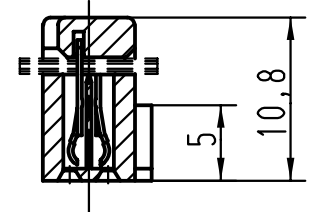

verrastet  
fitted  
assemble



- 1) Markierung erster Kontakt, Ader 1 des Flachkabels
- 1) Contact no.1, 1st contact wire of flat cable
- 1) Contact no.1, repère 1 du câble

		 All Dimensions in mm Original Size DIN A 4		Techn. Character.			Nicht tolerierte Masse/ Free size tolerances										
						Massstab/Scale  <b>2:1</b>		SEK 18 Female Connector 14 poles with central polarisation cover without cable stop									
09185145803		0,76 µm Au		Detail.						Dat.		Name					
09185146803		2		Insp.						01-FEB-00		JMV					
09185147803		3		Stand.													
Bestell-Nr. Part-No. Reference		Anforderungsstufe performance level Niveau de qualite		26570		01-FEB-00		JB		HARTING EURL F-95972 Paris				<b>TB 0918514X803</b>		Blatt/ page 1 / 1	
				Mod.		Dat.		Name									