

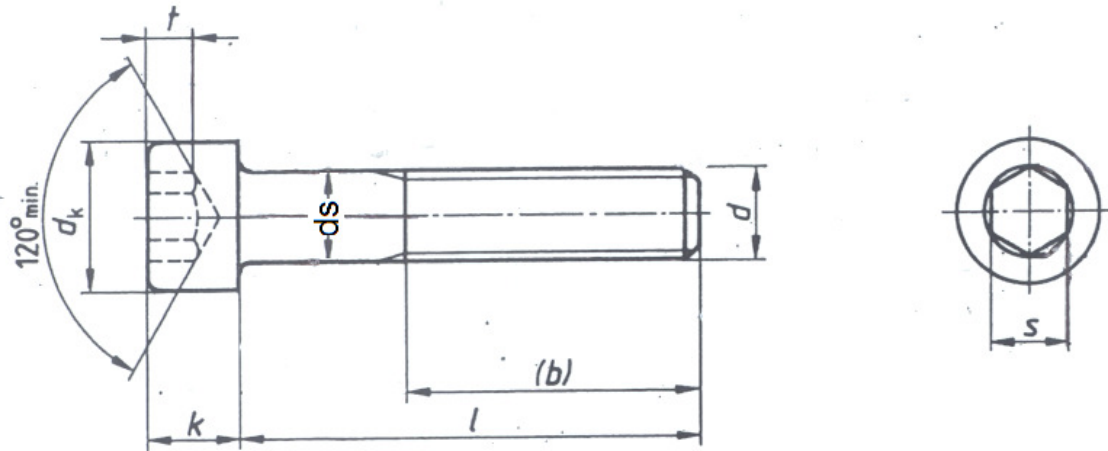

### Metric, Socket Head Cap Screws, Class 12.9, Black Oxide

The information below lists the required dimensional, chemical and physical characteristics of the products in this purchase order. If the order received does not meet these requirements, it may result in a supplier corrective action request, which could jeopardize your status as an approved vendor. Unless otherwise specified, all referenced consensus standards must be adhered to in their entirety.



Nominal Size (mm)	ds		dk		k		s			t
	Body Diameter		Head Diameter		Head Height		Socket Size			Key Engagement
	Max.	Min.	Max.	Min.	Max.	Min.	Nom.	Max.	Min.	Min.
M1.6	1.60	1.46	3.14	2.86	1.60	1.46	1.5	1.56	1.52	0.7
M2	2.00	1.86	3.98	3.62	2.00	1.86	1.5	1.56	1.52	1
M2.5	2.50	2.36	4.68	4.32	2.50	2.36	2	2.06	2.02	1.1
M3	3.00	2.86	5.68	5.32	3.00	2.86	2.5	2.58	2.52	1.3
M4	4.00	3.82	7.22	6.78	4.00	3.82	3	3.08	3.02	2
M5	5.00	4.82	8.72	8.28	5.00	4.82	4	4.095	4.02	2.5
M6	6.00	5.82	10.22	9.78	6.00	5.70	5	5.14	5.02	3
M8	8.00	7.78	13.27	12.73	8.00	7.64	6	6.14	6.02	4
M10	10.00	9.78	16.27	15.73	10.00	9.64	8	8.175	8.025	5
M12	12.00	11.73	18.27	17.73	12.00	11.57	10	10.175	10.025	6
M14	14.00	13.73	21.33	20.67	14.00	13.57	12	12.212	12.032	7
M16	16.00	15.73	24.33	23.67	16.00	15.57	14	14.212	14.032	8
M18 **	18.00	17.73	27.33	26.67	18.00	17.57	14	14.212	14.032	9
M20	20.00	19.67	30.33	29.67	20.00	19.48	17	17.23	17.05	10
M22 **	22.00	21.67	33.39	32.61	22.00	21.48	17	17.23	17.05	11
M24	24.00	23.67	36.39	35.61	24.00	23.48	19	19.275	19.065	12
M27 **	27.00	26.67	40.39	39.61	27.00	26.48	19	19.275	19.065	13.5
M30	30.00	29.67	45.39	44.61	30.00	29.48	22	22.275	22.065	15.5
M33 **	33.00	32.61	50.39	49.61	33.00	32.38	24	24.275	24.065	18
M36	36.00	35.61	54.46	53.54	36.00	35.38	27	27.275	27.065	19
M42	42.00	41.61	63.46	62.54	42.00	41.38	32	32.33	32.08	24

Page 2 of 2	<b>Product Standard</b>	REV-03
Date: March 23, 2015		HKI.M.SHCS.12.9.BO



### Specification Requirements:

- Dimensions: ISO 4762 \*\* DIN 912
- Threads: 5g6g
- Material & Mechanical Properties: ISO 898-1; Class 12.9
- Marking: Manufacturer's I.D. and 12.9
- Finish: Black Oxide (Thermal or Chemical)
- Manufacturer: Internationally Procured
- Material Test Reports: The MTR must have documented lot traceability, dimensional results, full chemical test results and full mechanical test results to the specification(s) above.