



MICROCHIP

**EVB-KSZ8563
Evaluation Board
User's Guide**

Note the following details of the code protection feature on Microchip devices:

- Microchip products meet the specification contained in their particular Microchip Data Sheet.
- Microchip believes that its family of products is one of the most secure families of its kind on the market today, when used in the intended manner and under normal conditions.
- There are dishonest and possibly illegal methods used to breach the code protection feature. All of these methods, to our knowledge, require using the Microchip products in a manner outside the operating specifications contained in Microchip's Data Sheets. Most likely, the person doing so is engaged in theft of intellectual property.
- Microchip is willing to work with the customer who is concerned about the integrity of their code.
- Neither Microchip nor any other semiconductor manufacturer can guarantee the security of their code. Code protection does not mean that we are guaranteeing the product as "unbreakable."

Code protection is constantly evolving. We at Microchip are committed to continuously improving the code protection features of our products. Attempts to break Microchip's code protection feature may be a violation of the Digital Millennium Copyright Act. If such acts allow unauthorized access to your software or other copyrighted work, you may have a right to sue for relief under that Act.

Information contained in this publication regarding device applications and the like is provided only for your convenience and may be superseded by updates. It is your responsibility to ensure that your application meets with your specifications. MICROCHIP MAKES NO REPRESENTATIONS OR WARRANTIES OF ANY KIND WHETHER EXPRESS OR IMPLIED, WRITTEN OR ORAL, STATUTORY OR OTHERWISE, RELATED TO THE INFORMATION, INCLUDING BUT NOT LIMITED TO ITS CONDITION, QUALITY, PERFORMANCE, MERCHANTABILITY OR FITNESS FOR PURPOSE. Microchip disclaims all liability arising from this information and its use. Use of Microchip devices in life support and/or safety applications is entirely at the buyer's risk, and the buyer agrees to defend, indemnify and hold harmless Microchip from any and all damages, claims, suits, or expenses resulting from such use. No licenses are conveyed, implicitly or otherwise, under any Microchip intellectual property rights unless otherwise stated.

Trademarks

The Microchip name and logo, the Microchip logo, AnyRate, AVR, AVR logo, AVR Freaks, BeaconThings, BitCloud, CryptoMemory, CryptoRF, dsPIC, FlashFlex, flexPWR, Helder, JukeBlox, KEELOQ, KEELOQ logo, Kleer, LANCheck, LINK MD, maXStylus, maXTouch, MediaLB, megaAVR, MOST, MOST logo, MPLAB, OptoLyzer, PIC, picoPower, PICSTART, PIC32 logo, Prochip Designer, QTouch, RightTouch, SAM-BA, SpyNIC, SST, SST Logo, SuperFlash, tinyAVR, UNI/O, and XMEGA are registered trademarks of Microchip Technology Incorporated in the U.S.A. and other countries.

ClockWorks, The Embedded Control Solutions Company, EtherSynch, Hyper Speed Control, HyperLight Load, IntelliMOS, mTouch, Precision Edge, and Quiet-Wire are registered trademarks of Microchip Technology Incorporated in the U.S.A.

Adjacent Key Suppression, AKS, Analog-for-the-Digital Age, Any Capacitor, AnyIn, AnyOut, BodyCom, chipKIT, chipKIT logo, CodeGuard, CryptoAuthentication, CryptoCompanion, CryptoController, dsPICDEM, dsPICDEM.net, Dynamic Average Matching, DAM, ECAN, EtherGREEN, In-Circuit Serial Programming, ICSP, Inter-Chip Connectivity, JitterBlocker, KlearNet, KlearNet logo, Mindi, MiWi, motorBench, MPASM, MPF, MPLAB Certified logo, MPLIB, MPLINK, MultiTRAK, NetDetach, Omniscient Code Generation, PICDEM, PICDEM.net, PICkit, PICtail, PureSilicon, QMatrix, RightTouch logo, REAL ICE, Ripple Blocker, SAM-ICE, Serial Quad I/O, SMART-I.S., SQI, SuperSwitcher, SuperSwitcher II, Total Endurance, TSHARC, USBCheck, VariSense, ViewSpan, WiperLock, Wireless DNA, and ZENA are trademarks of Microchip Technology Incorporated in the U.S.A. and other countries.

SQTP is a service mark of Microchip Technology Incorporated in the U.S.A.

Silicon Storage Technology is a registered trademark of Microchip Technology Inc. in other countries.

GestIC is a registered trademark of Microchip Technology Germany II GmbH & Co. KG, a subsidiary of Microchip Technology Inc., in other countries.

All other trademarks mentioned herein are property of their respective companies.

© 2018, Microchip Technology Incorporated, All Rights Reserved.

ISBN: 978-1-5224-3016-2

**QUALITY MANAGEMENT SYSTEM
CERTIFIED BY DNV
= ISO/TS 16949 =**

Microchip received ISO/TS-16949:2009 certification for its worldwide headquarters, design and wafer fabrication facilities in Chandler and Tempe, Arizona; Gresham, Oregon and design centers in California and India. The Company's quality system processes and procedures are for its PIC® MCUs and dsPIC® DSCs, KEELOQ® code hopping devices, Serial EEPROMs, microperipherals, nonvolatile memory and analog products. In addition, Microchip's quality system for the design and manufacture of development systems is ISO 9001:2000 certified.

Table of Contents

Preface	5
Introduction.....	5
Document Layout	5
Conventions Used in this Guide	6
The Microchip Web Site	7
Development Systems Customer Change Notification Service	7
Customer Support	7
Document Revision History	8
Chapter 1. Overview	
1.1 Introduction	9
1.2 References	10
Chapter 2. Board Details and Configuration	
2.1 Introduction	11
2.2 Power Source	11
2.2.1 Power Probe Points	11
2.2.2 Current Access Rework/Probe Points	11
2.3 Clock	11
2.4 Reset	12
2.4.1 Power-On Reset	12
2.4.2 Manual Reset	12
2.5 Board Features and Configuration	12
2.5.1 PHY Ports - Integrated Magnetic Jacks	15
2.5.2 PHY Ports - LEDs	15
2.5.3 Pin Strapping Configuration	15
2.5.4 GPIO Signal Headers	15
2.5.5 INTRP_N Output	16
2.5.6 PME_N Output	16
2.6 Using the EVB-KSZ8563	16
Appendix A. EVB-KSZ8563 Evaluation Board	
A.1 Introduction	19
Appendix B. EVB-KSZ8563 Schematics	
B.1 Introduction	21
Appendix C. EVB-KSZ8563 Bill of Materials (BOM)	
C.1 Introduction	25
Appendix D. EVB-KSZ8563 Silk Screen	
D.1 Introduction	29
Worldwide Sales and Service	32

NOTES:

Preface

NOTICE TO CUSTOMERS

All documentation becomes dated, and this manual is no exception. Microchip tools and documentation are constantly evolving to meet customer needs, so some actual dialogs and/or tool descriptions may differ from those in this document. Please refer to our web site (www.microchip.com) to obtain the latest documentation available.

Documents are identified with a “DS” number. This number is located on the bottom of each page, in front of the page number. The numbering convention for the DS number is “DSXXXXA”, where “XXXX” is the document number and “A” is the revision level of the document.

For the most up-to-date information on development tools, see the MPLAB® IDE online help. Select the Help menu, and then Topics to open a list of available online help files.

INTRODUCTION

This chapter contains general information that will be useful to know before using the KSZ8563. Items discussed in this chapter include:

- [Document Layout](#)
- [Conventions Used in this Guide](#)
- [The Microchip Web Site](#)
- [Development Systems Customer Change Notification Service](#)
- [Customer Support](#)
- [Document Revision History](#)

DOCUMENT LAYOUT

This document describes how to use the EVB-KSZ8563 Evaluation Board as a development tool for the KSZ8563, 3-Port Fast Ethernet Switch with RGMII Interface and IEEE 1588v2 / 802.1AS support.

- **Chapter 1. “Overview”** – This chapter provides a brief description of the EVB-KSZ8563 Evaluation Board.
- **Chapter 2. “Board Details and Configuration”** – This chapter includes instructions on how to get started with the EVB-KSZ8563 Evaluation Board.
- **Appendix A. “EVB-KSZ8563 Evaluation Board”** – This appendix shows the physical EVB-KSZ8563 Evaluation Board.
- **Appendix B. “EVB-KSZ8563 Schematics”** – This appendix shows the EVB-KSZ8563 Evaluation Board schematics.
- **Appendix C. “EVB-KSZ8563 Bill of Materials (BOM)”** – This appendix includes the EVB-KSZ8563 Evaluation Board Bill of Materials (BOM).
- **Appendix D. “EVB-KSZ8563 Silk Screen”** – This appendix includes the EVB-KSZ8563 Evaluation Board silk screen.

CONVENTIONS USED IN THIS GUIDE

This manual uses the following documentation conventions:

Description	Represents	Examples
Arial font:		
Italic characters	Referenced books	<i>MPLAB[®] IDE User's Guide</i>
	Emphasized text	...is the <i>only</i> compiler...
Initial caps	A window	the Output window
	A dialog	the Settings dialog
	A menu selection	select Enable Programmer
Quotes	A field name in a window or dialog	"Save project before build"
Underlined, italic text with right angle bracket	A menu path	<u><i>File>Save</i></u>
Bold characters	A dialog button	Click OK
	A tab	Click the Power tab
N'Rnnnn	A number in verilog format, where N is the total number of digits, R is the radix and n is a digit.	4'b0010, 2'hF1
Text in angle brackets < >	A key on the keyboard	Press <Enter>, <F1>
Courier New font:		
Plain Courier New	Sample source code	#define START
	Filenames	autoexec.bat
	File paths	c:\mcc18\h
	Keywords	_asm, _endasm, static
	Command-line options	-Opa+, -Opa-
	Bit values	0, 1
	Constants	0xFF, 'A'
Italic Courier New	A variable argument	<i>file.o</i> , where <i>file</i> can be any valid filename
Square brackets []	Optional arguments	mcc18 [options] <i>file</i> [options]
Curly brackets and pipe character: { }	Choice of mutually exclusive arguments; an OR selection	errorlevel {0 1}
Ellipses...	Replaces repeated text	var_name [, var_name...]
	Represents code supplied by user	void main (void) { ... }

THE MICROCHIP WEB SITE

Microchip provides online support via our web site at www.microchip.com. This web site is used as a means to make files and information easily available to customers. Accessible by using your favorite Internet browser, the web site contains the following information:

- **Product Support** – Data sheets and errata, application notes and sample programs, design resources, user's guides and hardware support documents, latest software releases and archived software
- **General Technical Support** – Frequently Asked Questions (FAQs), technical support requests, online discussion groups, Microchip consultant program member listing
- **Business of Microchip** – Product selector and ordering guides, latest Microchip press releases, listing of seminars and events, listings of Microchip sales offices, distributors and factory representatives

DEVELOPMENT SYSTEMS CUSTOMER CHANGE NOTIFICATION SERVICE

Microchip's customer notification service helps keep customers current on Microchip products. Subscribers will receive e-mail notification whenever there are changes, updates, revisions or errata related to a specified product family or development tool of interest.

To register, access the Microchip web site at www.microchip.com, click on Customer Change Notification and follow the registration instructions.

The Development Systems product group categories are:

- **Compilers** – The latest information on Microchip C compilers, assemblers, linkers and other language tools. These include all MPLAB C compilers; all MPLAB assemblers (including MPASM assembler); all MPLAB linkers (including MPLINK object linker); and all MPLAB librarians (including MPLIB object librarian).
- **Emulators** – The latest information on Microchip in-circuit emulators. This includes the MPLAB REAL ICE and MPLAB ICE 2000 in-circuit emulators.
- **In-Circuit Debuggers** – The latest information on the Microchip in-circuit debuggers. This includes MPLAB ICD 3 in-circuit debuggers and PICkit 3 debug express.
- **MPLAB IDE** – The latest information on Microchip MPLAB IDE, the Windows Integrated Development Environment for development systems tools. This list is focused on the MPLAB IDE, MPLAB IDE Project Manager, MPLAB Editor and MPLAB SIM simulator, as well as general editing and debugging features.
- **Programmers** – The latest information on Microchip programmers. These include production programmers such as MPLAB REAL ICE in-circuit emulator, MPLAB ICD 3 in-circuit debugger and MPLAB PM3 device programmers. Also included are nonproduction development programmers such as PICSTART Plus and PIC-kit 2 and 3.

CUSTOMER SUPPORT

Users of Microchip products can receive assistance through several channels:

- Distributor or Representative
- Local Sales Office
- Field Application Engineer (FAE)
- Technical Support

EVB-KSZ8563 Evaluation Board User's Guide

Customers should contact their distributor, representative or field application engineer (FAE) for support. Local sales offices are also available to help customers. A listing of sales offices and locations is included in the back of this document.

Technical support is available through the web site at:

<http://www.microchip.com/support>

DOCUMENT REVISION HISTORY

Revisions	Section/Figure/Entry	Correction
DS50002755A (05-10-18)	Initial release.	

Chapter 1. Overview

1.1 INTRODUCTION

The EVB-KSZ8563 evaluation board is a plug-in card that interfaces directly with a mating Microchip host processor/controller board, such as the SAMA5D3-EDS Board. It features the KSZ8563, a highly-integrated networking device that incorporates a layer-2+ managed Fast Ethernet switch, two 10BASE-T/100BASE-TX physical layer transceivers (PHYs) and associated MAC units, and one MAC port configured as the RGMII interface. The board's two PHY ports are connected to RJ45 Ethernet jacks with integrated magnetics, and the RGMII MAC interface is brought out to a high-speed multi-pin (HS) connector.

As a set, the EVB-KSZ8563 and SAMA5D3-EDS Board provide a highly-flexible platform to allow evaluation of basic KSZ8563 PHY/Switch features using static control-status registers (CSRs) to develop firmware of advanced KSZ8563 MAC/Switch features, such as IEEE1588 PTP, AVB, and RSTP/MSTP that require interaction with upper network layers.

The scope of this document is meant to describe the EVB-KSZ8563 evaluation board setup and its user interface features. A simplified block diagram of the board is shown in [Figure 1-1](#).

FIGURE 1-1: EVB-KSZ8563 FUNCTIONAL BLOCK DIAGRAM

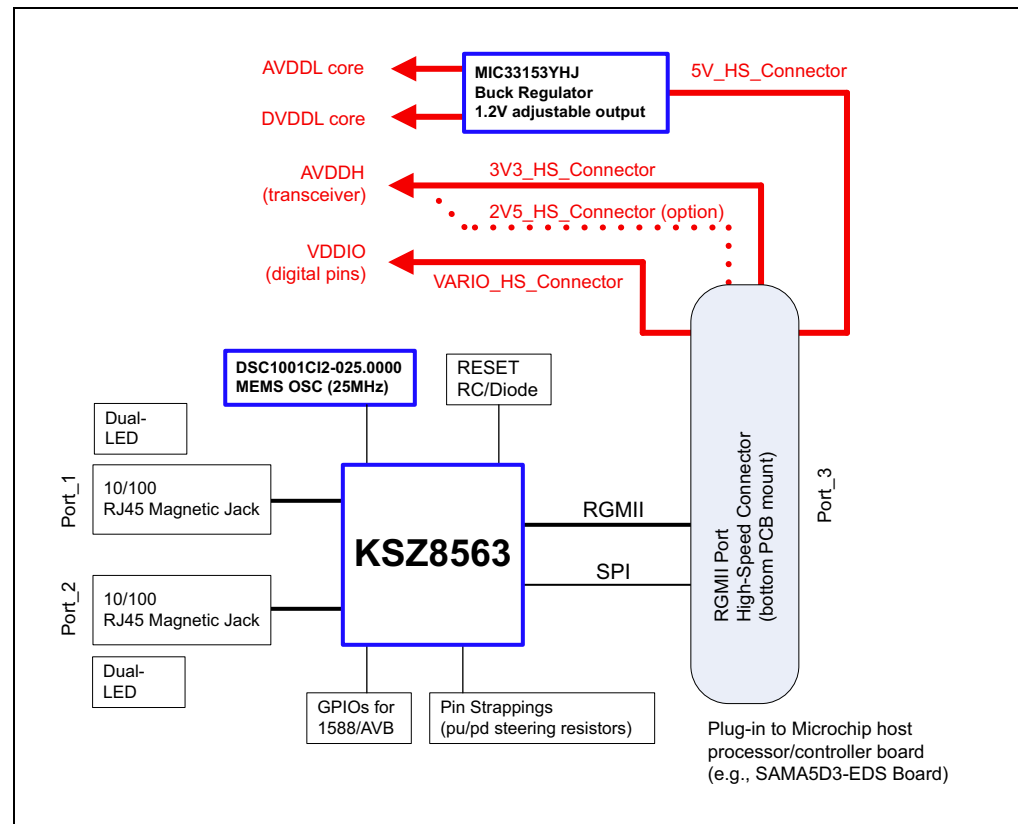

1.2 REFERENCES

Concepts and materials available in the following documents may be helpful when reading this document. Visit www.microchip.com for the latest documentation.

- *KSZ8563 Data Sheet*
- *EVB-KSZ8563 Schematics*
- *SAMA5D3-EDS Schematics*
- *SAMA5D3-EDS Board User's Guide*
- *MIC33153YHJ Data Sheet*
- *DSC1001 Data Sheet*

Chapter 2. Board Details and Configuration

2.1 INTRODUCTION

The EVB-KSZ8563 is designed as a plug-in card to interface directly with a mating Microchip host processor or controller board, such as the SAMA5D3-EDS Board, that supplies full power and provides full register access and configuration via IBA, SPI, or I²C bus management.

2.2 POWER SOURCE

The EVB-KSZ8563 is completely bus-powered from its mating Microchip host processor or controller board. Input power is delivered via the high-speed multi-pin (HS) connector.

Refer to [Figure 2-3](#) and board schematics in [Appendix B. “EVB-KSZ8563 Schematics”](#) for details.

2.2.1 Power Probe Points

The power probe points along with the ground test points are shown in [Figure 2-2](#).

2.2.2 Current Access Rework/Probe Points

The EVB-KSZ8563 design is not intended to perform current measurements on the device. If needed, the current access points to measure the current consumption of the KSZ8563 power rails are across the following series ferrite beads to the board powers.

- DVDDL: FB2
- AVDDL: FB3
- VDDIO: FB6
- AVDDH: FB4 for 3.3V (default populate); FB1 for 2.5V (default not populate)

Note: Populate either FB4 only or FB1 only. If 2.5V AVDDH is desired, FB4 should be 'do not populate' (DNP) and FB1 should be populated.

Remove the above ferrite beads and place the current probes in series across the power probe points ([Section 2.2.1 “Power Probe Points”](#)) that are joined by the ferrite beads. See also [Appendix B. “EVB-KSZ8563 Schematics”](#).

Board LED components are connected to the VDDIO power rail, and thus the measured current is higher than the amount consumed by only the KSZ8563 device.

2.3 CLOCK

The EVB-KSZ8563 utilizes the on-board Microchip DSC1001CI2-025.0000 clock chip, a 25-MHz MEMS oscillator, as the input reference clock to the KSZ8563 device. Refer to [Figure 2-1](#) and board schematics in [Appendix B. “EVB-KSZ8563 Schematics”](#) for details.

2.4 RESET

2.4.1 Power-On Reset

The discrete RC/Diode (R12, C8, D3) circuit provides power-on reset to the KSZ8563 device.

2.4.2 Manual Reset

The SW1 reset button can be pressed and released to provide manual reset to the KSZ8563 device after power-up. Refer to [Figure 2-1](#) and board schematics in [Appendix B. "EVB-KSZ8563 Schematics"](#) for details.

2.5 BOARD FEATURES AND CONFIGURATION

The following sub-sections describe the board features and configuration settings.

[Figure 2-1](#) displays the top view of the EVB-KSZ8563 with key features, jumpers, and headers highlighted in red, and with Microchip components highlighted in blue.

FIGURE 2-1: EVB-KSZ8563 TOP VIEW WITH CALLOUTS

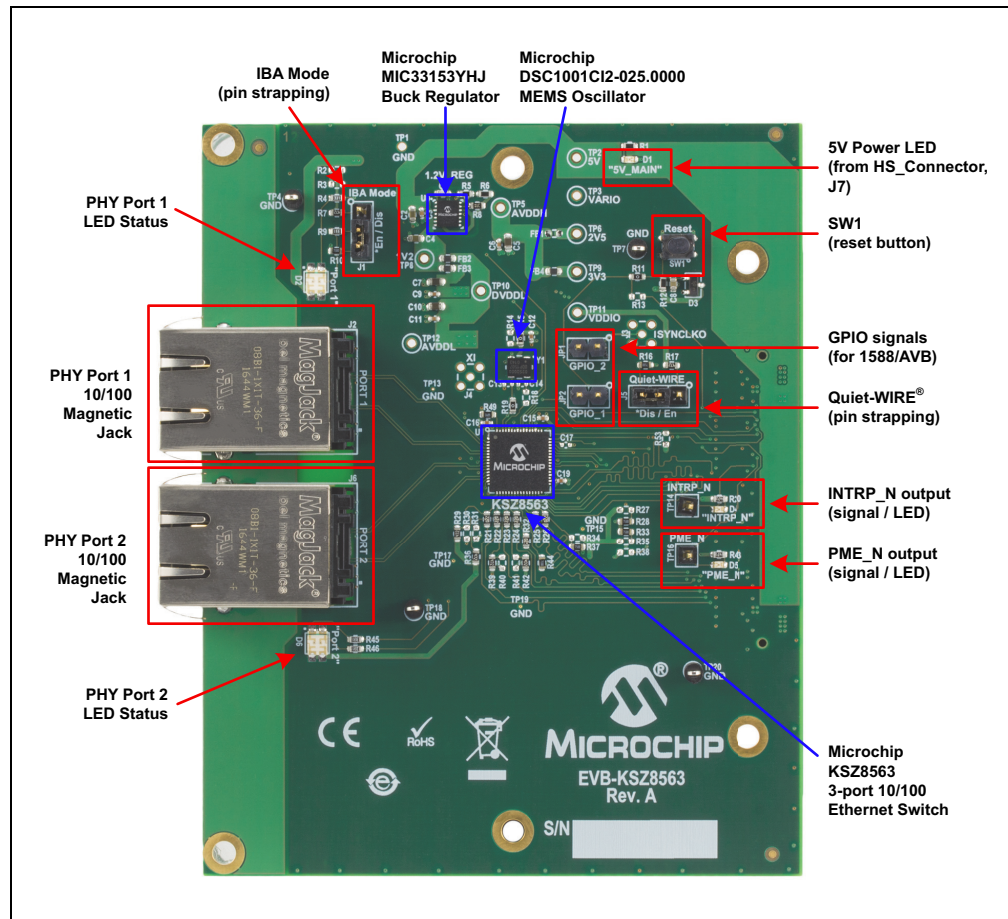

Board Details and Configuration

Figure 2-2 displays the power probe points along with the ground test points.

FIGURE 2-2: EVB-KSZ8563 POWER/GROUND CALLOUTS

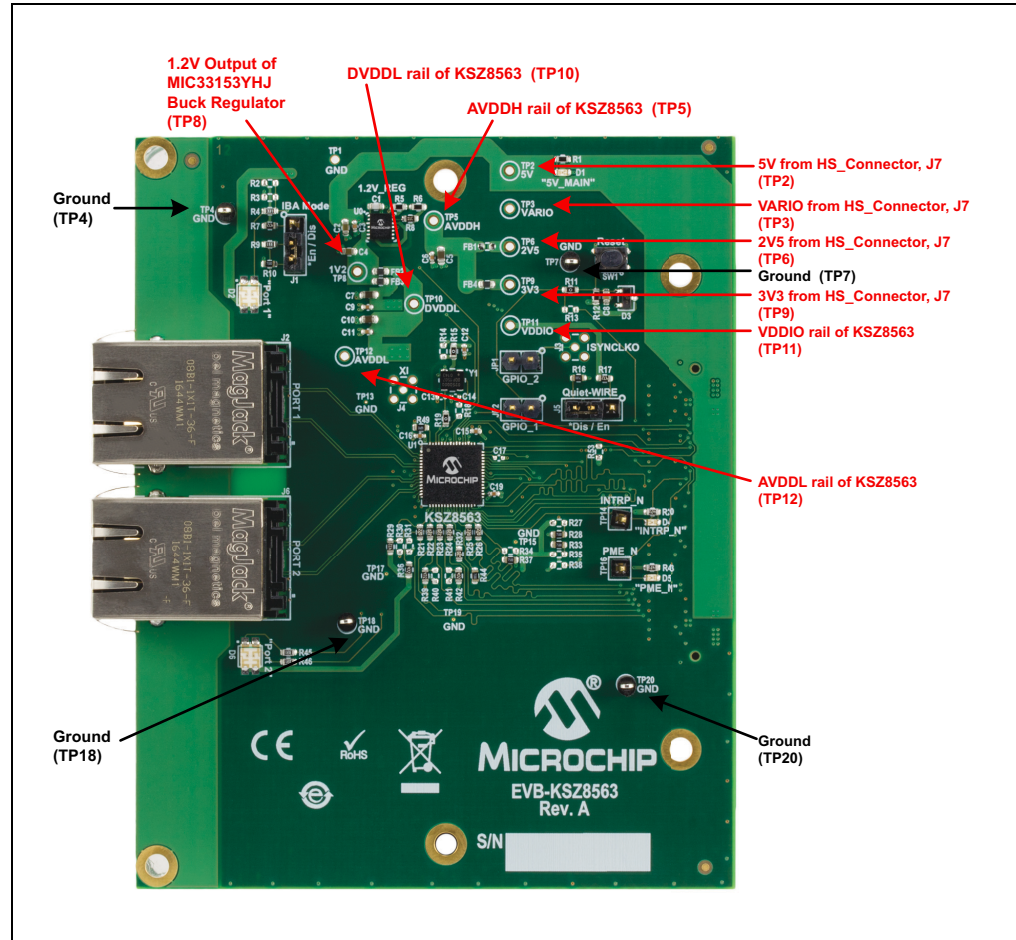
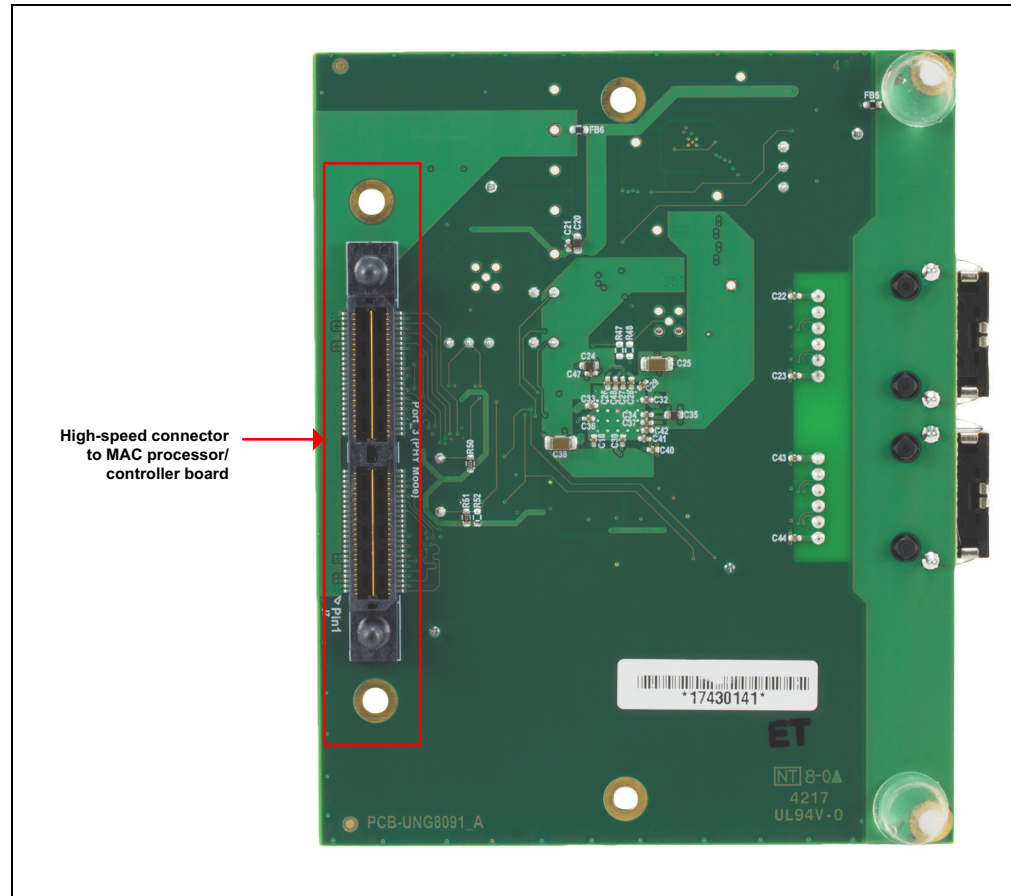

Figure 2-3 displays the bottom view of the EVB-KSZ8563 with the HS connector (J7) (highlighted in red) that plugs directly into a mating Microchip MAC processor or controller board.

FIGURE 2-3: EVB-KSZ8563 BOTTOM VIEW WITH CALLOUT



Board Details and Configuration

2.5.1 PHY Ports - Integrated Magnetic Jacks

PHY ports 1 and 2 (J2 and J6) support 10BASE-T/100BASE-TX with both Auto-Negotiation and Auto MDI/MDI-X enabled as the power-up defaults.

2.5.2 PHY Ports - LEDs

Two Dual-LEDs (D2 and D6) provide the link status for PHY ports 1 and 2, respectively. The LED descriptions are listed in [Table 2-1](#).

TABLE 2-1: PHY PORTS - LED DESCRIPTION

LED	LED Color	Description
D2, D6	Red	Solid Color: 100-Mbps Link Blinking: Activity (RX, TX)
	Orange	Solid Color: 10-Mbps Link Blinking: Activity (RX, TX)
	Off	Link off

2.5.3 Pin Strapping Configuration

As the power-up or reset defaults, the KSZ8563 device is configured via internal or external pull-up/down resistors to the following settings:

- **PHY Ports 1 and 2:** Auto-Negotiation enabled and Energy-Efficient Ethernet (EEE) enabled
- **MAC Port 3:** RGMII Mode at 1000-Mbps speed
- **Start Switch:** The switch forwards the packets immediately after hardware reset.
- **Management:** SPI Slave mode

The In-band Management Access (IBA) Mode and Quiet-Wire[®] pin strappings can be enabled or disabled using the 3-pin jumpers in [Table 2-2](#). Set the desired jumper settings prior to board power-up, hardware reset, or both.

TABLE 2-2: PIN STRAPPING JUMPERS

Jumper	Label	Description	Close Pins 1-2	Close Pins 2-3
J1	IBA Mode	IBA provides full register read and write access via any one of the three data ports. When enabled by pin strapping, IBA defaults to PHY port 1. SPI or I ² C management access is required to enable IBA for MAC port 3 or PHY port 2.	Disable	Enable (default)
J5	Quiet-Wire	Quiet-Wire filtering is implemented on-chip to enhance 100BASE-TX EMC performance by reducing both conducted and radiated emissions from the TXP/M signal differential pair.	Enable	Disable (default)

Refer to the board schematics in [Appendix B. “EVB-KSZ8563 Schematics”](#) and the *KSZ8563 Data Sheet* for further details on the pin strappings.

2.5.4 GPIO Signal Headers

[Table 2-3](#) shows the GPIO signals that support the IEEE 1588 Precision Time Protocol (PTP).

TABLE 2-3: GPIO SIGNAL HEADERS

Header	Label	Description	Pin 1	Pin 2
JP1	GPIO_2	The GPIO_2 pin is configurable to implement IEEE1588 event trigger outputs and time stamp capture inputs to support real-time application requirements.	No Connect	GPIO_2 (KSZ8563 pin 41)
JP2	GPIO_1	The GPIO_1 pin is configurable to implement IEEE1588 event trigger outputs and time stamp capture inputs to support real-time application requirements.	Ground	GPIO_1 (KSZ8563 pin 40)

Refer to the board schematics in [Appendix B. “EVB-KSZ8563 Schematics”](#) and the *KSZ8563 Data Sheet* for further details and usage on the GPIO signal pins.

2.5.5 INTRP_N Output

The INTRP_N output at test point TP14 provides the interrupt output from the KSZ8563 device. By default, it is active low and drives low to turn on D4 when asserted.

Refer to board schematics in [Appendix B. “EVB-KSZ8563 Schematics”](#) and *KSZ8563 Data Sheet* for further details and usage on the INTRP_N signal.

2.5.6 PME_N Output

The PME_N output at test point TP16 provides the Power Management Event (PME) interrupt output for Wake-on-LAN (WoL) from the KSZ8563 device. By default, it is active low and drives low to turn on D5 when asserted.

Refer to the board schematics in [Appendix B. “EVB-KSZ8563 Schematics”](#) and the *KSZ8563 Data Sheet* for further details and usage on the PME_N signal.

2.6 USING THE EVB-KSZ8563

The EVB-KSZ8563 plugs in directly to a mating Microchip host controller or processor board, such as the SAMA5D3-EDS Board, that delivers full power and provides full register access and configuration via IBA, SPI, or I²C bus management.

Together, the EVB-KSZ8563 and the SAMA5D3-EDS enable Ethernet traffic switching across all three data ports of the KSZ8563 device with RGMII MAC port 3 connecting to the SAMA5D3 processor and PHY ports 1 and 2 connecting via copper Ethernet cable (CAT-5 UTP or better) to external Ethernet devices.

All KSZ8563 registers are accessible via IBA, SPI, or I²C bus management from the SAMA5D3-EDS Board, enabling full evaluation and firmware development for all KSZ8563 MAC/Switch features and interaction with upper network layers.

Refer to SAMA5D3-EDS Board documentation on its usage.

[Figure 2-4](#) shows the EVB-KSZ8563 connected to the SAMA5D3-EDS Board.

Board Details and Configuration

FIGURE 2-4: EVB-KSZ8563/SAMA5D3-EDS EVALUATION AND FIRMWARE DEVELOPMENT PLATFORM

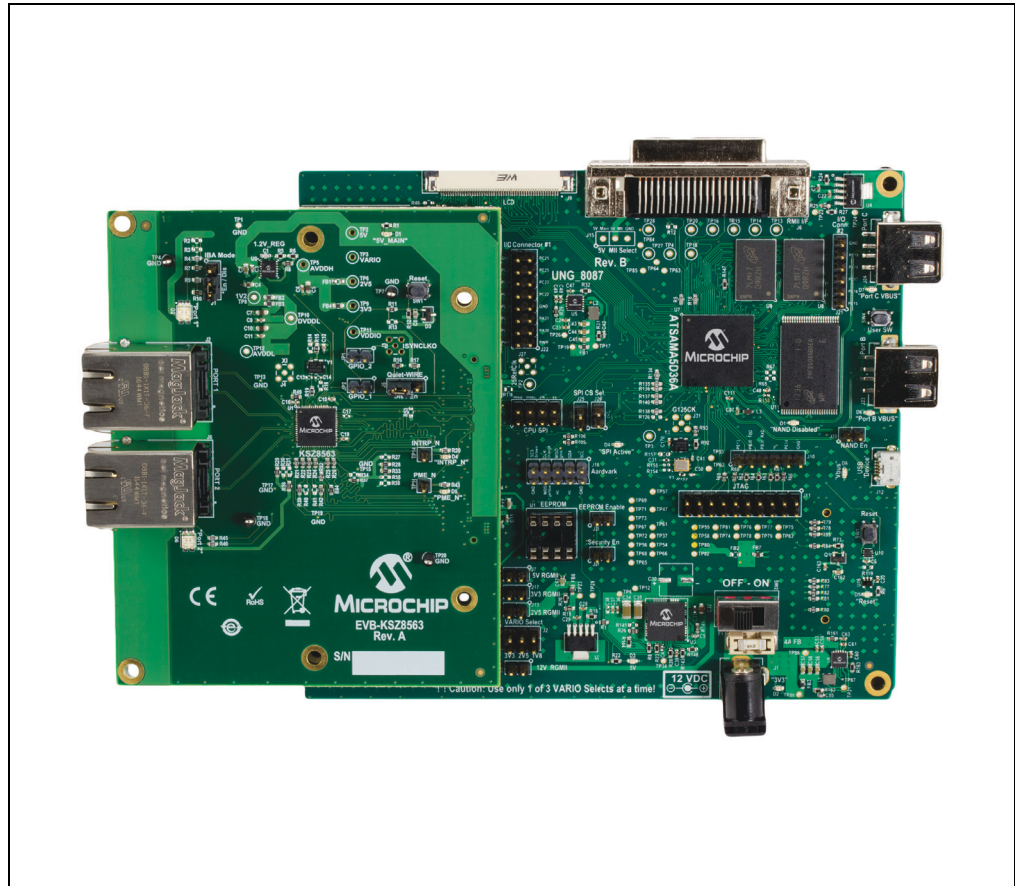

NOTES:

Appendix A. EVB-KSZ8563 Evaluation Board

A.1 INTRODUCTION

This appendix shows the EVB-KSZ8563 evaluation board.

FIGURE A-1: EVB-KSZ8563 EVALUATION BOARD (TOP VIEW)

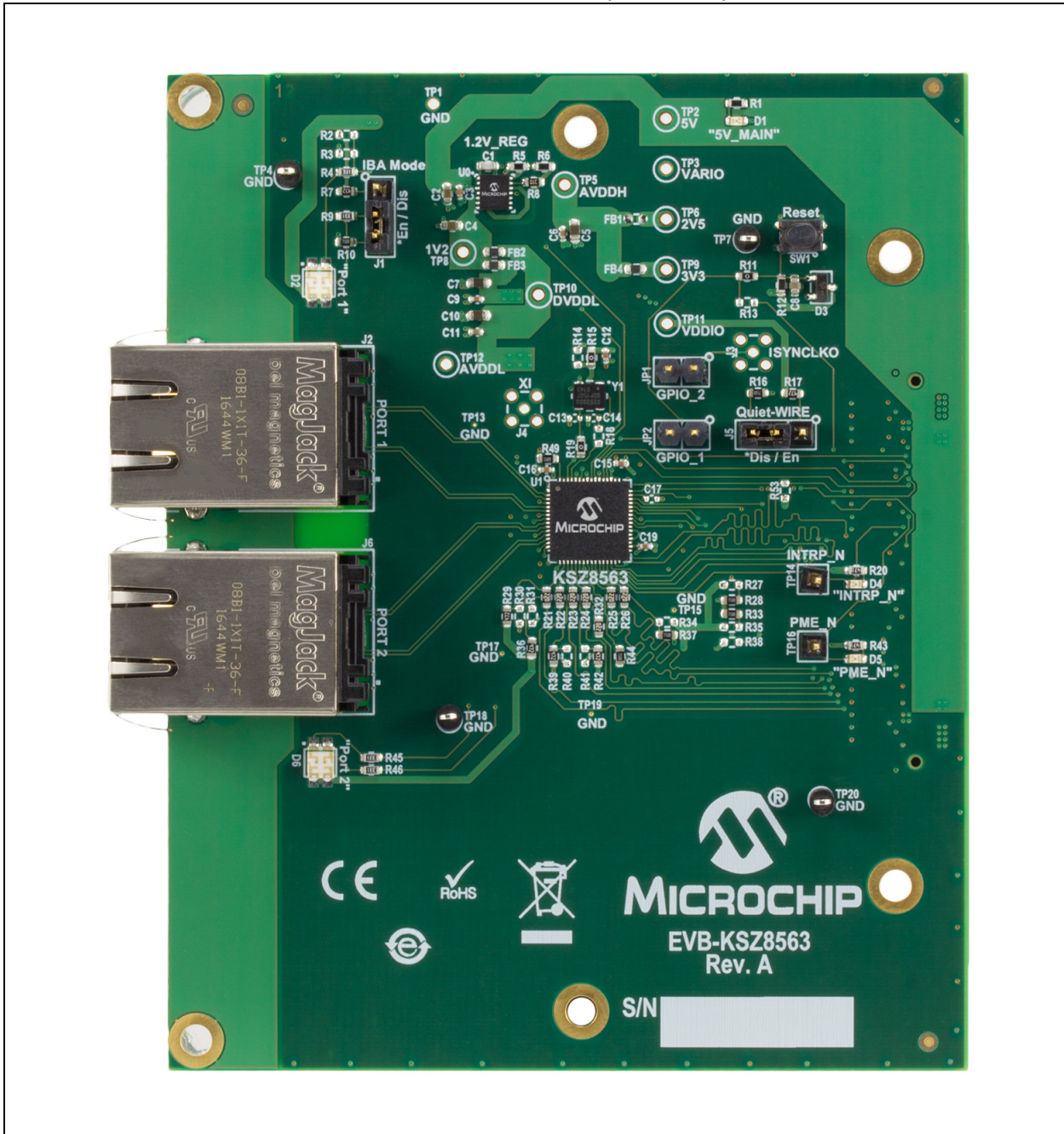
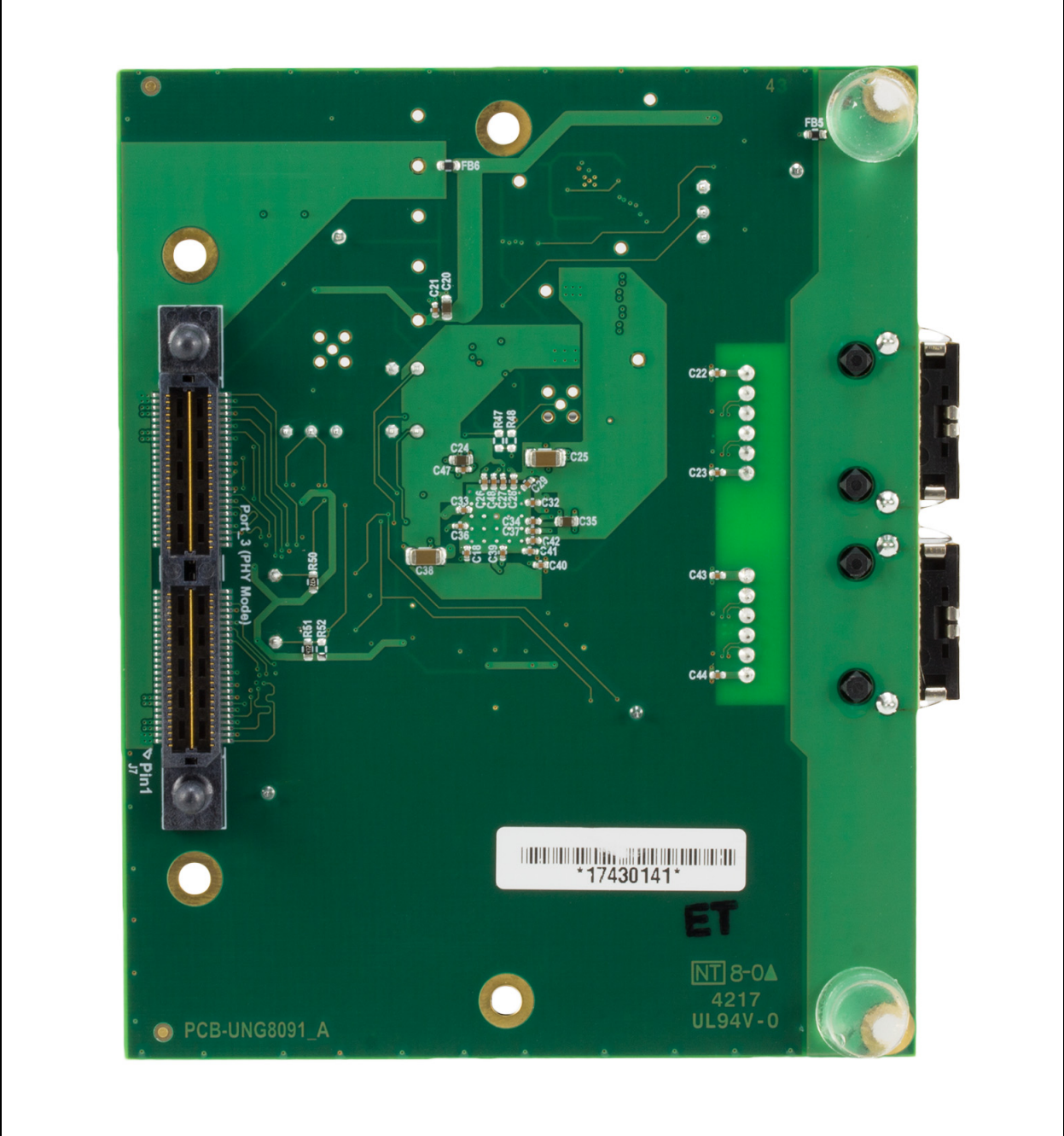

FIGURE A-2: EVB-KSZ8563 EVALUATION BOARD (BOTTOM VIEW)





Appendix B. EVB-KSZ8563 Schematics

B.1 INTRODUCTION

This appendix includes the EVB-KSZ8563 schematics.

FIGURE B-1: EVB-KS28563 SCHEMATICS - KS28563 DEVICE, PIN STRAPPING, CLOCK, AND RESET

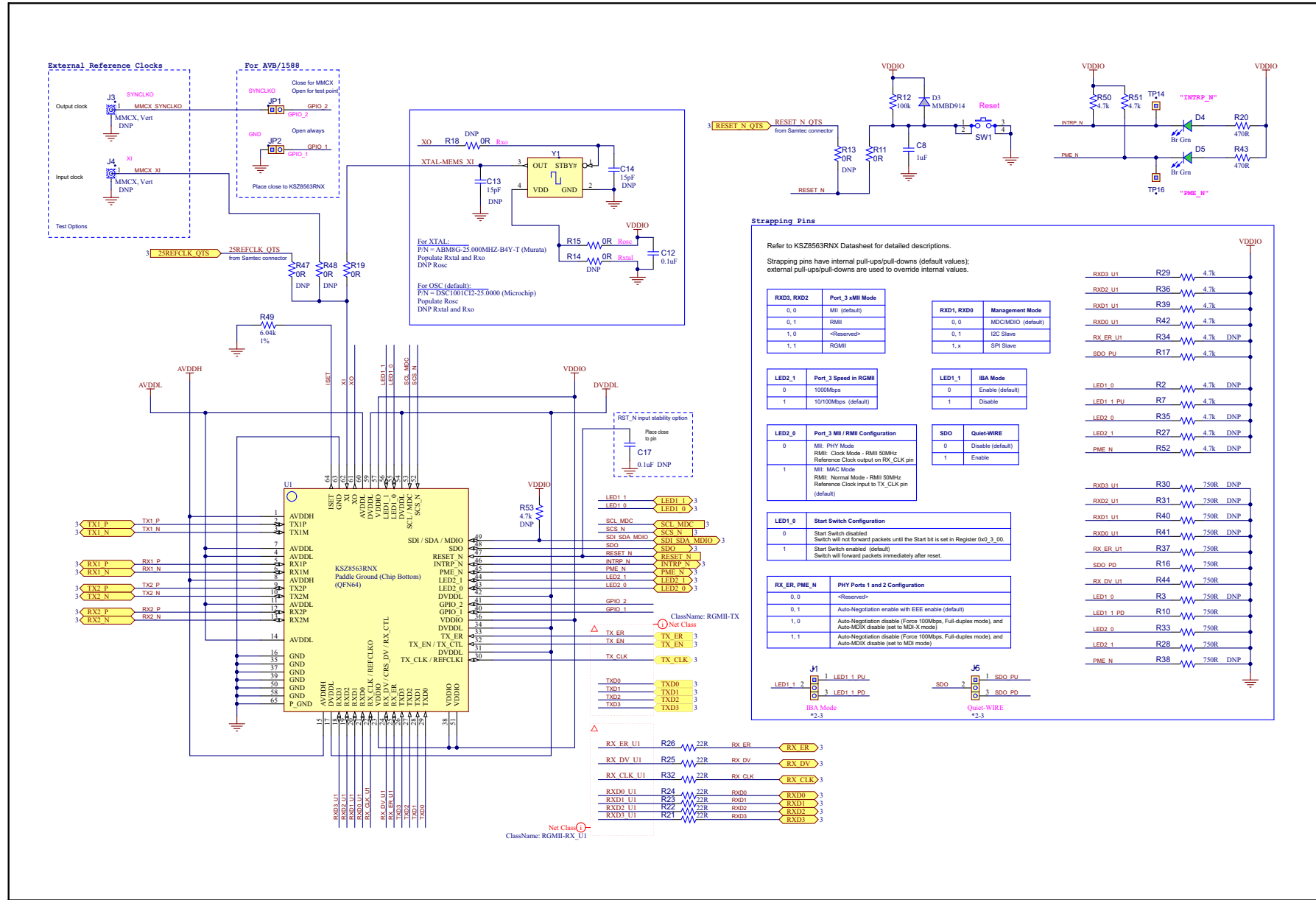
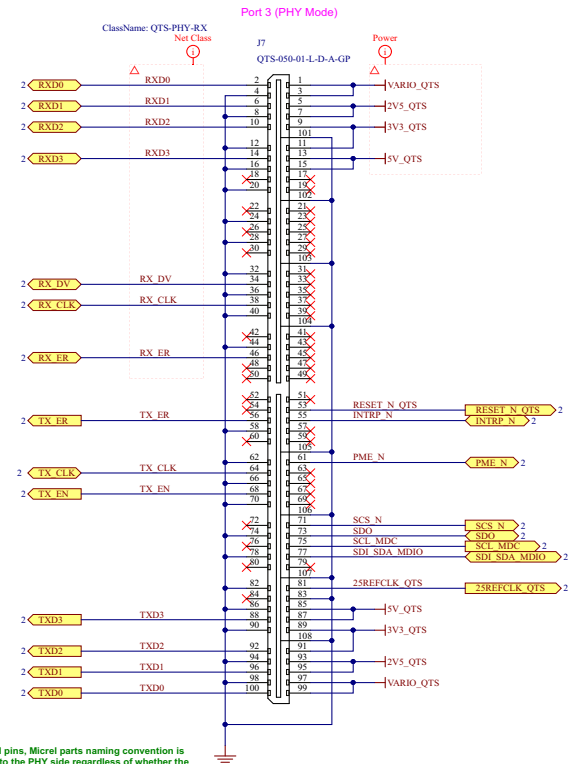
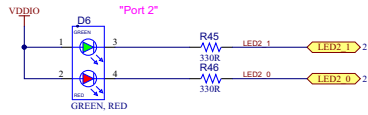
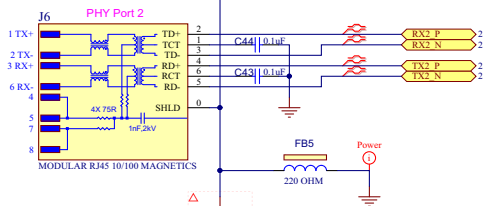
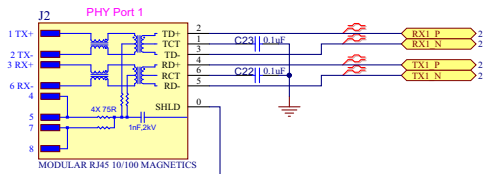
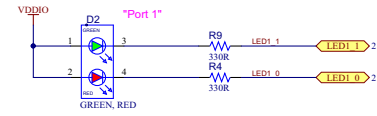

FIGURE B-2: EVB-KSZ8563 SCHEMATICS - PORTS 1, 2 PHYS; PORT 3 MAC - MII/RMII/RGMII CONNECTOR



PCB Layout Constraint:
Match trace lengths between the KSZ8563RNX device and the Samtec connectors for each of the following Class Name groupings:
* RGMII-RX_U1 + QTS-PHY-RX
* RGMII-TX

For the xMII pins, Micrel parts naming convention is referenced to the PHY side regardless of whether the switch is in MAC mode or PHY mode. That is, "TX" named pins are inputs and "RX" named pins are outputs for MAC mode and PHY mode.

Tri-color Dual-LED Mode
(power-up default setting)

Pins (LEDx_1, LEDx_0)	Description	Dual-LED Color
[0, 1]	-Reserved (not used)-	Green
[1, 0] [1, toggling]	Solid Color : 100M Link Blinking : Activity (RX, TX)	Red
[0, 0] [toggling, toggling]	Solid Color : 10M Link Blinking : Activity (RX, TX)	Orange
[1, 1]	Link off	<<off>>

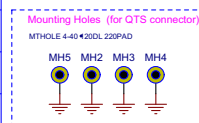
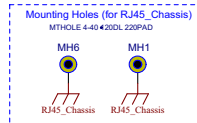

PHY Mode
MII / RMII / RGMII Port
TOP VIEW - component placement side pin-outs
(mount on Bottom Side of Board)

FIGURE B-3: EVB-KSZ8563 SCHEMATICS - BOARD POWER I/O AND REGULATORS

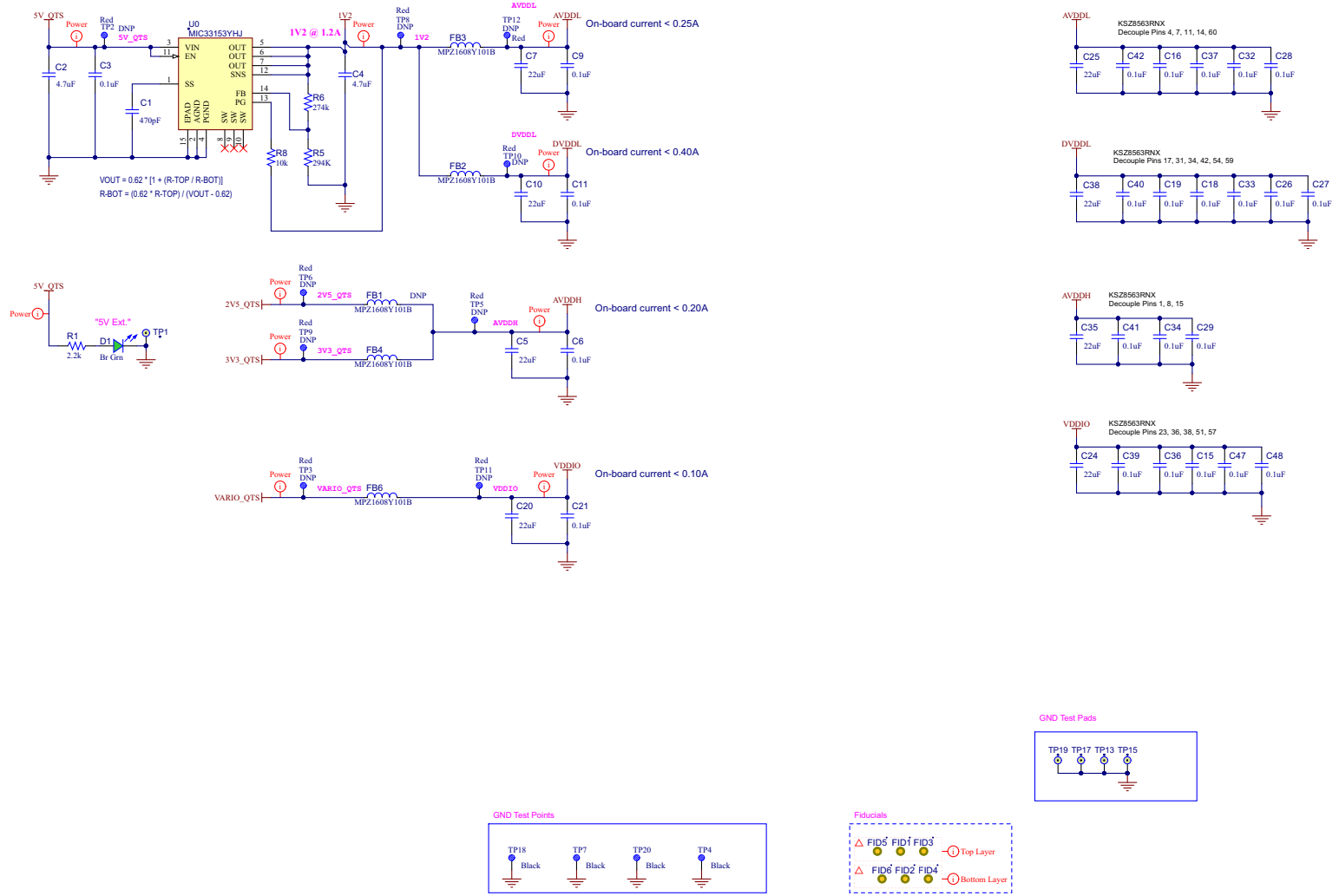



Appendix C. EVB-KSZ8563 Bill of Materials (BOM)

C.1 INTRODUCTION

This appendix includes the EVB-KSZ8563 Bill of Materials (BOM).

FIGURE C-1: BILL OF MATERIALS

Item	Qty	Reference	Description	Populated	Manufacturer	Manufacturer Part Number
1	2	C13, C14	CAP CER 15 pF 50V 5% NP0 SMD 0402	YES	Murata	GRM1555C1H150JA01D
2	1	C1	CAP CER 470 pF 25V 5% NP0 SMD 0603	YES	AVX	06033A471JAT2A
3	2	C2, C4	CAP CER 4.7 uF 10V 10% X5R SMD 0603	YES	KEMET	C0603C475K8PACTU
4	22	C3, C6, C9, C11, C15, C16, C18, C19, C21, C26, C27, C28, C29, C32, C33, C34, C36, C37, C39, C40, C41, C42	CAP CER 0.1 uF 50V 10% X7R SMD 0402	YES	TDK Corporation	C1005X7R1H104K050BB
5	6	C5, C7, C10, C20, C24, C35	CAP CER 22 uF 10V 20% X5R SMD 0603	YES	TDK Corporation	C1608X5R1A226M080AC
6	1	C8	CAP CER 1 uF 16V 10% X5R SMD 0603	YES	AVX	0603YD105KAT2A
7	7	C12, C22, C23, C43, C44, C47, C48	CAP CER 0.1 uF 50V 10% X7R SMD 0402	YES	TDK Corporation	C1005X7R1H104K050BB
8	2	C25, C38	CAP CER 22 uF 10V 20% X5R SMD 1206	YES	Taiyo Yuden	LMK316BJ226ML-T
9	3	D1, D4, D5	LED, Bright Green, 0603	YES	Lite-On	LTST-C191KGKT
10	2	D2, D6	DIO LED BI GREEN, RED 2V 30 mA 1210	YES	Lite-On	LTST-C155KGJRK
11	1	D3	DIO RECT MMBD914LT1G 1V 10 mA 100V SMD SOT-23-3	YES	ON Semiconductor	MMBD914LT1G
12	4	FB2, FB3, FB4, FB6	FERRITE CHIP 100 OHM 2A 0603	YES	TDK Corporation	MPZ1608Y101B
13	1	FB5	FERRITE 500 mA 220R SMD 0603	YES	Murata Electronics North America	BLM18AG221SN1D
14	2	J1, J5	HDR 3POS 100" SGL GOLD	YES	Samtec Inc.	TSW-103-07-G-S
15	2	J2, J6	CON MODULAR RJ45 MAGJACK TH R/A, NO LED	YES	Bel Fuse Inc.	08B1-1X1T-36-F
16	2	JP1, JP2	CON HDR-2.54 MALE 1x2 GOLD 5.84 MH TH VERT	YES	FCI	68000-236HLF
17	1	R1	RES TKF 2.2k 1% 1/10W SMD 0603	YES	Panasonic	ERJ-3EKF2201V
18	4	R4, R9, R45, R46	RES TKF 330R 5% 1/10W SMD 0603	YES	Panasonic Electronic Components	ERJ-3GEYJ331V
19	1	R5	RES TKF 294K 1% 1/10W SMD 0603	YES	Panasonic Electronic Components	ERJ-3EKF2943V
20	1	R6	RES TKF 274K 1% 1/10W SMD 0603	YES	Panasonic Electronic Components	ERJ-3EKF2743V
21	8	R7, R17, R29, R36, R39, R42, R50, R51	RES TKF 4.7k 5% 1/10W SMD 0603	YES	Yageo	RC0603JR-074K7L
22	1	R8	RES TKF 10k 5% 1/10W SMD 0603	YES	Panasonic	ERJ-3GEYJ103V
23	6	R10, R16, R28, R33, R37, R44	RES TKF 750R 1% 1/10W SMD 0603	YES	Vishay	CRCW0603750RFKEA
24	4	R11, R14, R18, R19	RES TKF 0R 1/10W SMD 0603	YES	NIC Components	NRC06Z0TRF
25	1	R12	RES TKF 100k 1% 1/10W SMD 0603	YES	Panasonic	ERJ-3EKF1003V
26	2	R20, R43	RES TKF 470R 5% 1/10W SMD 0603	YES	Panasonic	ERJ-3GEYJ471V
27	7	R21, R22, R23, R24, R25, R26, R32	RES TKF 22R 1% 1/10W SMD 0603	YES	Yageo	RC0603FR-0722RL
28	1	R49	RES TKF 6.04k 1% 1/10W SMD 0603	YES	Yageo	9T06031A6041FBHFT
29	1	SW1	Switch, Tactile, SPST, 50 mA, 16VDC, J-lead, 4.2 x 3.2 mm, PTS810, NO	YES	C&K	PTS810 SJM 250 SMTR LFS
30	4	TP4, TP7, TP18, TP20	TEST POINT PC MINI 0.040"D BLACK	YES	Keystone Electronics	5001
31	2	TP14, TP16	CON HDR-2.54 MALE 1x1 GOLD 5.84 MH TH VERT	YES	Samtec	TSW-101-07-G-S

Item	Qty	Reference	Description	Populated	Manufacturer	Manufacturer Part Number
32	1	U1	KSZ8563RNX 3-Port 10/100 Ethernet Switch with AVB/1588	YES	Microchip Technology	KSZ8563RNX
33	1	U0	IC, 2.7V to 5.5V input, 1.2A, Synchronous 4MHz Buck Regulator with adjustable output	YES	Microchip Technology	MIC33153YHJ
34	1	J7	SAMTEC - QTS-050-01-L-D-A-GP -0.635 mm DOUBLE ROW HS SOCKET ASSEMBLY	YES	SAMTEC	QTS-050-01-L-D-A-GP
35	1	Y1	CRYSTAL 25 MHz 10 pF SMD ABM8G	YES	Abracon LLC	ABM8G-25.000MHZ-4Y-T3
36	0	C13, C14	CAP CER 15 pF 50V 5% NP0 SMD 0402	NO	Murata	GRM1555C1H150JA01D
37	0	C17	CAP CER 0.1 uF 50V 10% X7R SMD 0402	NO	TDK Corporation	C1005X7R1H104K050BB
38	0	FB1	FERRITE CHIP 100 OHM 2A 0603	NO	TDK Corporation	MPZ1608Y101B
39	0	J3, J4	CONN MMCX JACK STR 50 OHM PCB	NO	Cinch Connectivity Solutions Johnson	135-3701-211
40	0	R2, R27, R34, R35, R52, R53	RES TKF 4.7k 5% 1/10W SMD 0603	NO	Yageo	RC0603JR-074K7L
41	0	R3, R30, R31, R38, R40, R41	RES TKF 750R 1% 1/10W SMD 0603	NO	Vishay	CRCW0603750RFKEA
42	0	R13, R15, R47, R48	RES TKF 0R 1/10W SMD 0603	NO	NIC Components	NRC06Z0TRF
43	0	TP2, TP3, TP5, TP6, TP8, TP9, TP10, TP11, TP12	TEST POINT PC MINI 0.040"D RED	NO	Keystone Electronics	5000

NOTES:

Appendix D. EVB-KSZ8563 Silk Screen

D.1 INTRODUCTION

This appendix shows the EVB-KSZ8563 top and bottom silk screen images.

FIGURE D-1: EVB-KSZ8563 TOP SILK SCREEN

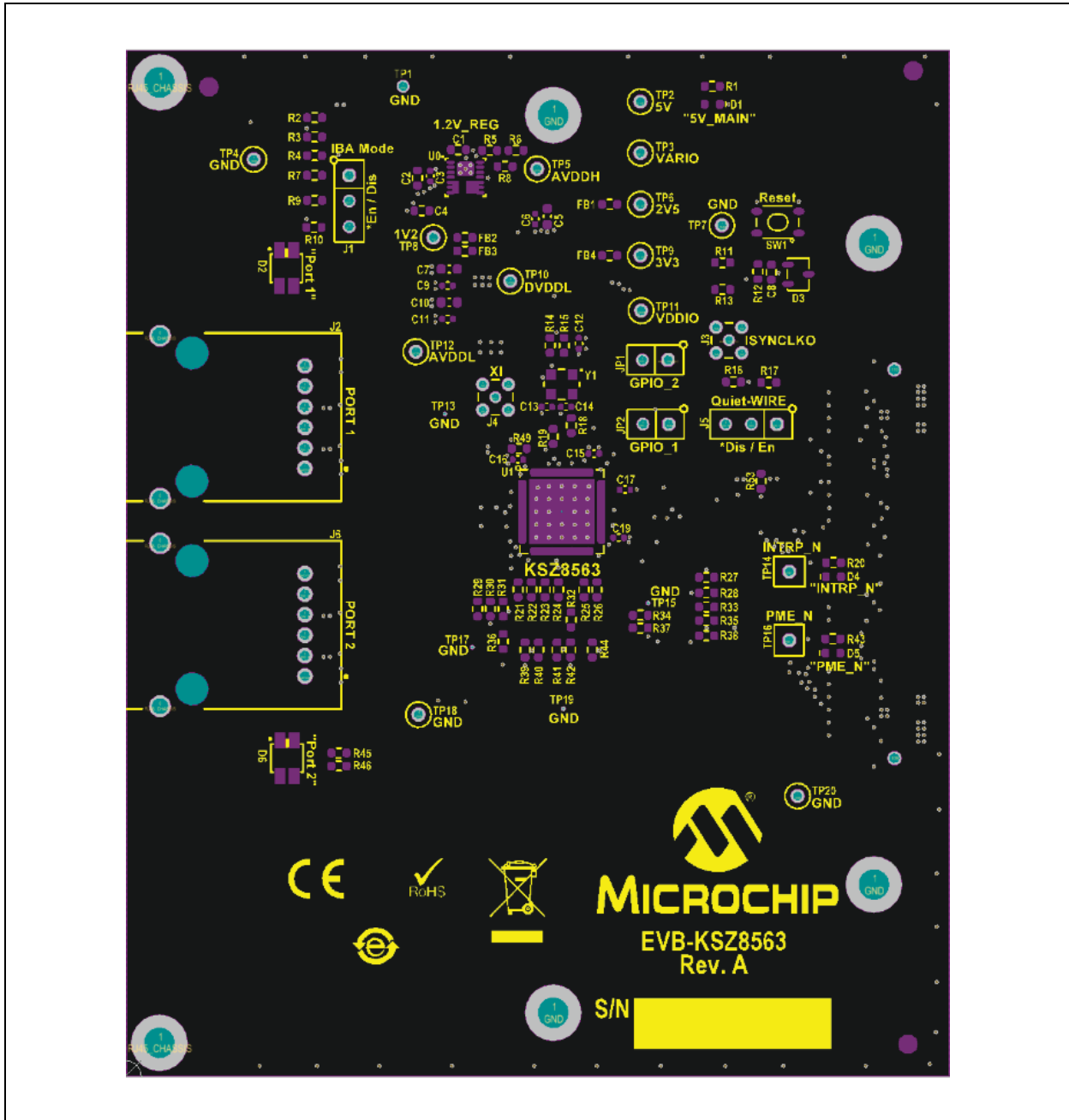
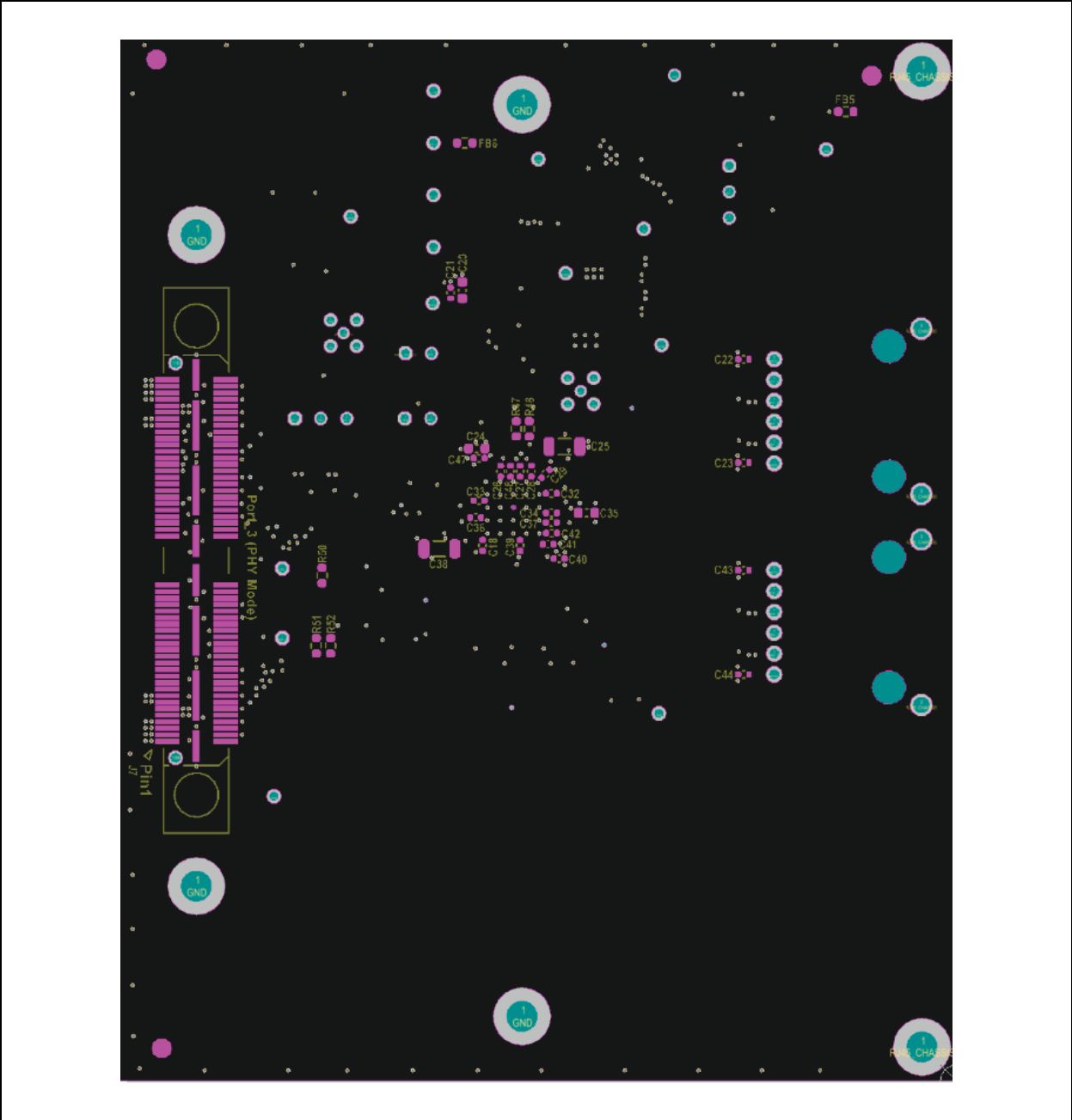

FIGURE D-2: EVB-KSZ8563 BOTTOM SILK SCREEN



NOTES:



MICROCHIP

Worldwide Sales and Service

AMERICAS

Corporate Office
2355 West Chandler Blvd.
Chandler, AZ 85224-6199
Tel: 480-792-7200
Fax: 480-792-7277
Technical Support:
<http://www.microchip.com/support>
Web Address:
www.microchip.com

Atlanta

Duluth, GA
Tel: 678-957-9614
Fax: 678-957-1455

Austin, TX

Tel: 512-257-3370

Boston

Westborough, MA
Tel: 774-760-0087
Fax: 774-760-0088

Chicago

Itasca, IL
Tel: 630-285-0071
Fax: 630-285-0075

Dallas

Addison, TX
Tel: 972-818-7423
Fax: 972-818-2924

Detroit

Novi, MI
Tel: 248-848-4000

Houston, TX

Tel: 281-894-5983

Indianapolis

Noblesville, IN
Tel: 317-773-8323
Fax: 317-773-5453
Tel: 317-536-2380

Los Angeles

Mission Viejo, CA
Tel: 949-462-9523
Fax: 949-462-9608
Tel: 951-273-7800

Raleigh, NC

Tel: 919-844-7510

New York, NY

Tel: 631-435-6000

San Jose, CA

Tel: 408-735-9110
Tel: 408-436-4270

Canada - Toronto

Tel: 905-695-1980
Fax: 905-695-2078

ASIA/PACIFIC

Australia - Sydney
Tel: 61-2-9868-6733

China - Beijing
Tel: 86-10-8569-7000

China - Chengdu
Tel: 86-28-8665-5511

China - Chongqing
Tel: 86-23-8980-9588

China - Dongguan
Tel: 86-769-8702-9880

China - Guangzhou
Tel: 86-20-8755-8029

China - Hangzhou
Tel: 86-571-8792-8115

China - Hong Kong SAR
Tel: 852-2943-5100

China - Nanjing
Tel: 86-25-8473-2460

China - Qingdao
Tel: 86-532-8502-7355

China - Shanghai
Tel: 86-21-3326-8000

China - Shenyang
Tel: 86-24-2334-2829

China - Shenzhen
Tel: 86-755-8864-2200

China - Suzhou
Tel: 86-186-6233-1526

China - Wuhan
Tel: 86-27-5980-5300

China - Xian
Tel: 86-29-8833-7252

China - Xiamen
Tel: 86-592-2388138

China - Zhuhai
Tel: 86-756-3210040

ASIA/PACIFIC

India - Bangalore
Tel: 91-80-3090-4444

India - New Delhi
Tel: 91-11-4160-8631

India - Pune
Tel: 91-20-4121-0141

Japan - Osaka
Tel: 81-6-6152-7160

Japan - Tokyo
Tel: 81-3-6880-3770

Korea - Daegu
Tel: 82-53-744-4301

Korea - Seoul
Tel: 82-2-554-7200

Malaysia - Kuala Lumpur
Tel: 60-3-7651-7906

Malaysia - Penang
Tel: 60-4-227-8870

Philippines - Manila
Tel: 63-2-634-9065

Singapore
Tel: 65-6334-8870

Taiwan - Hsin Chu
Tel: 886-3-577-8366

Taiwan - Kaohsiung
Tel: 886-7-213-7830

Taiwan - Taipei
Tel: 886-2-2508-8600

Thailand - Bangkok
Tel: 66-2-694-1351

Vietnam - Ho Chi Minh
Tel: 84-28-5448-2100

EUROPE

Austria - Wels
Tel: 43-7242-2244-39
Fax: 43-7242-2244-393

Denmark - Copenhagen
Tel: 45-4450-2828
Fax: 45-4485-2829

Finland - Espoo
Tel: 358-9-4520-820

France - Paris
Tel: 33-1-69-53-63-20
Fax: 33-1-69-30-90-79

Germany - Garching
Tel: 49-8931-9700

Germany - Haan
Tel: 49-2129-3766400

Germany - Heilbronn
Tel: 49-7131-67-3636

Germany - Karlsruhe
Tel: 49-721-625370

Germany - Munich
Tel: 49-89-627-144-0
Fax: 49-89-627-144-44

Germany - Rosenheim
Tel: 49-8031-354-560

Israel - Ra'anana
Tel: 972-9-744-7705

Italy - Milan
Tel: 39-0331-742611
Fax: 39-0331-466781

Italy - Padova
Tel: 39-049-7625286

Netherlands - Drunen
Tel: 31-416-690399
Fax: 31-416-690340

Norway - Trondheim
Tel: 47-7289-7561

Poland - Warsaw
Tel: 48-22-3325737

Romania - Bucharest
Tel: 40-21-407-87-50

Spain - Madrid
Tel: 34-91-708-08-90
Fax: 34-91-708-08-91

Sweden - Gothenberg
Tel: 46-31-704-60-40

Sweden - Stockholm
Tel: 46-8-5090-4654

UK - Wokingham
Tel: 44-118-921-5800
Fax: 44-118-921-5820

Mouser Electronics

Authorized Distributor

Click to View Pricing, Inventory, Delivery & Lifecycle Information:

[Microchip:](#)

[EVB-KSZ8563](#)