

1

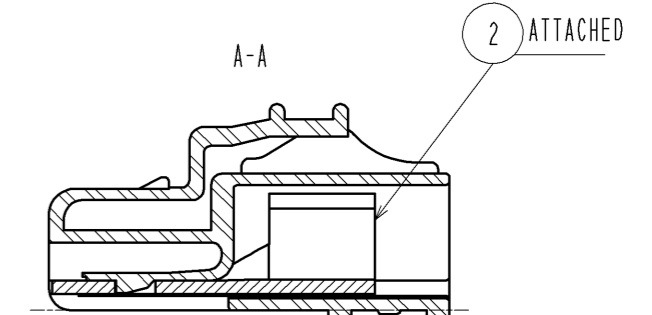

5 REF. No. ② IS EXPOSED.

PARTS NO. ②

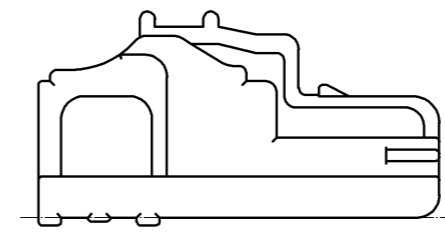
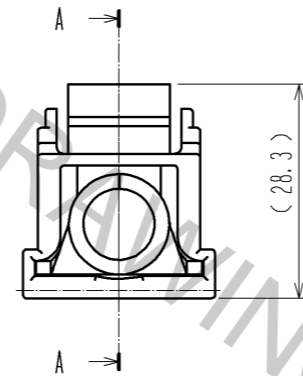
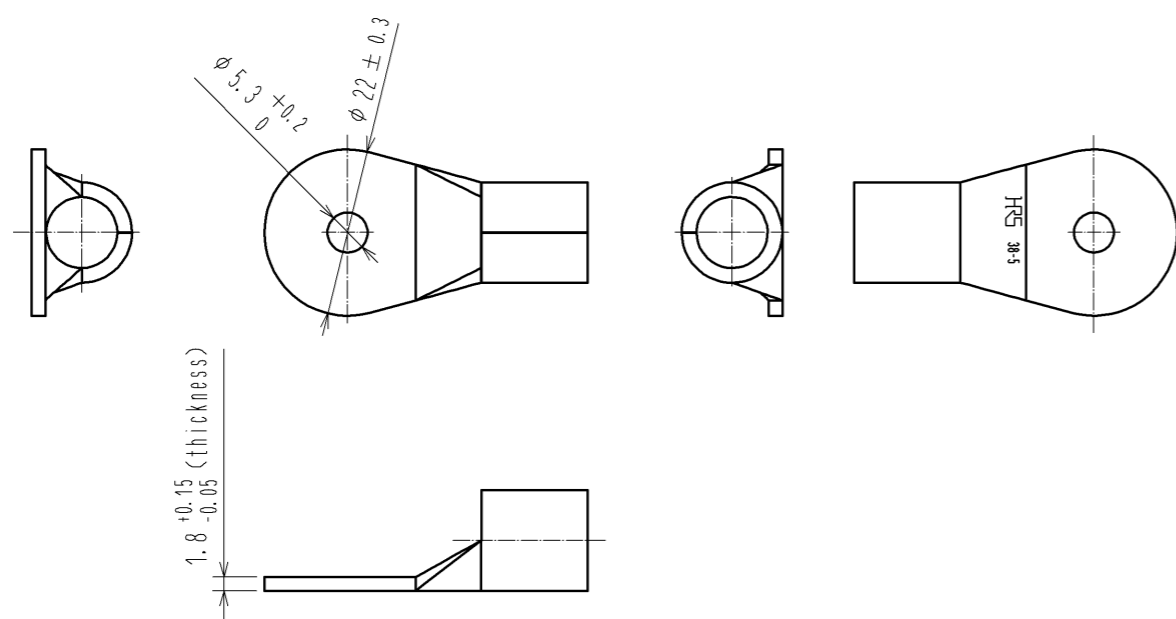

NOTES 1 APPLICABLE CRIMPING TOOL:

- JIS C9711 IZUMISEIKI CO., LTD. 9H-60 OR REC 150F.
  - ⚠ WARNING 2 THE CONNECTOR IS NOT HOT PLUGABLE.
  - 3 REFER TO ASSEMBLY PROCEDURE MANUAL (ETAD-C0294).
  - 4 REFER TO HANDLING PROCEDURE MANUAL (ETAD-C0307).
  - ⚠ WARNING 5 KEEP YOUR FINGERS AND OTHER CONDUCTORS FROM COMING IN CONTACT WITH REF. No. ② IN ELECTRICALLY CHARGED CONDITIONS IN ORDER TO AVOID ELECTRICAL SHOCK AND SHORT-CIRCUIT.
  - ⚠ WARNING 6 MAKE SURE THAT THE CONNECTOR IS INSERTED TO THE END AND LOCKED WHEN MATED. CONFIRM THAT THE CONNECTOR IS NOT UNINTENTIONALLY RELEASED BY PULLING THE CABLE WITH LIGHT FORCE TO PREVENT INCOMPLETE MATING CONDITION.
  - 7 CRIMP TERMINALS AS SHOWN BELOW ARE ALSO APPLICABLE. ⚠ 1 NICHIFU CO., LTD. R 38-5. JST CO., LTD. 38-5.
- ATTENTIONS PRIOR TO USE :
- DIMENSIONS SHALL SATISFY THAT OF IN REF. No. 2, AND NO DEFORMATION OR CONTAMINATION IS OBSERVED.
  - CONTACT RESISTANCE MUST BE BELOW THE STANDARD VALUE.
  - USE ONLY TIN PLATING TERMINAL.
- ⚠ WARNING • EVALUATE PRIOR TO USE, AS TIN PLATING CONDITION COULD AFFECT THE PERFORMANCE.

1	PBT	UL94V-0 (BLACK)	2	COPPER ALLOY	TIN PLATING 1μm min.		
NO.	MATERIAL	FINISH . REMARKS	NO.	MATERIAL	FINISH . REMARKS		
UNITS mm		SCALE 1 : 1	COUNT 1	DESCRIPTION OF REVISIONS DIS-C-003173	DESIGNED KN. IKEHARA	CHECKED HY. KOBAYASHI	DATE 13. 09. 11
<b>HRS</b> HIROSE ELECTRIC CO., LTD.		APPROVED : SU. OBARA	13. 06. 15	DRAWING NO. EDC3-118254-00			
		CHECKED : HY. KOBAYASHI	13. 06. 14	PART NO. EF1-38P-1PCD			
		DESIGNED : HS. KAWASHIMA	13. 06. 14	CODE NO. CL142-0012-0-00			
		DRAWN : KN. IKEHARA	13. 06. 13			1/1	