



# LM111-LM211-LM311

## Adjustable 0.6V Open Collector Shunt Voltage Reference

- Maximum input current: 150nA
- Maximum offset current: 20nA
- Differential input voltage range:  $\pm 30V$
- Power consumption: 135mW at  $\pm 15V$
- Supply voltage: +5V to  $\pm 15V$
- Output current: 50mA

### Description

The LM111, LM211, LM311 are voltage comparators that have low input currents.

They are also designed to operate over a wide range of supply voltages : from standard  $\pm 15V$  operational amplifier supplies down to the single +5V supply used for IC logic.

Their output is compatible with RTL-DTL and TTL as well as MOS circuits and can switch voltages up to +50V at outputs currents as high as 50mA.

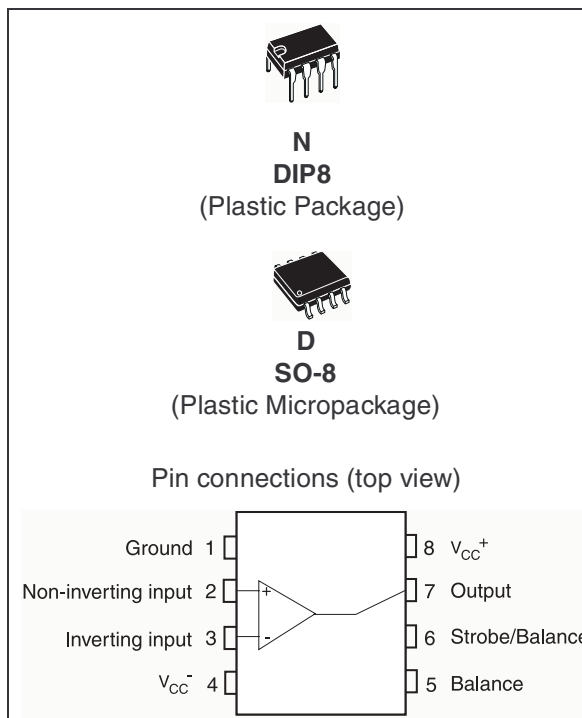

### Order Codes

Part Number	Temperature Range	Package	Packing	Marking
LM211N	-40°C, +105°C	DIP8	Tube	LM211N
LM211D/DT		SO-8	Tube or Tape & Reel	211
LM311N	0°C, +70°C	DIP8	Tube	LM311
LM311D/DT		SO-8	Tube or Tape & Reel	311

# 1 Absolute Maximum Ratings & Operating Conditions

**Table 1. Absolute maximum ratings (AMR)**

Symbol	Parameter	Value	Unit
$V_{CC}$	Supply Voltage	36	V
$V_{id}$	Differential Input Voltage	$\pm 30$	V
$V_i$	Input Voltage <sup>(1)</sup>	$\pm 15$	V
$V_{(1-4)}$	Ground to Negative Supply Voltage	30	V
$V_{(7-4)}$	Output to Negative Supply Voltage		
	LM111-LM211 LM311	50 40	V
	Output Short-Circuit Duration	10	s
	Voltage at strobe pin	$V_{CC}^+ - 5$	V
$P_d$	Power Dissipation <sup>(2)</sup>		
	<b>DIP8</b> <b>SO-8</b>	1250 710	mW
$T_j$	Junction Temperature	+150	°C
$T_{stg}$	Storage Temperature Range	-65 to +150	°C

1. This rating applies for  $\pm 15V$  supplies. The positive input voltage limit is 30V above the negative. The negative input voltage is equal to the negative supply voltage or 30V below the positive supply, whichever is less.
2.  $P_d$  is calculated with  $T_{amb} = +25^\circ C$ ,  $T_j = +150^\circ C$  and  $R_{thja} = 100^\circ C/W$  for DIP8 package =  $175^\circ C/W$  for SO-8 package

**Table 2. Operating conditions**

Symbol	Parameter	Value	Unit
$V_{CC}$	Supply Voltage	5 to $\pm 15$	V
$T_{oper}$	Operating Free-Air Temperature range		
	LM111	-55 to +125	°C
	LM211	-40 to +105	
	LM311	0 to +70	

## 2 Typical Application Schematic

Figure 1. Schematic diagram

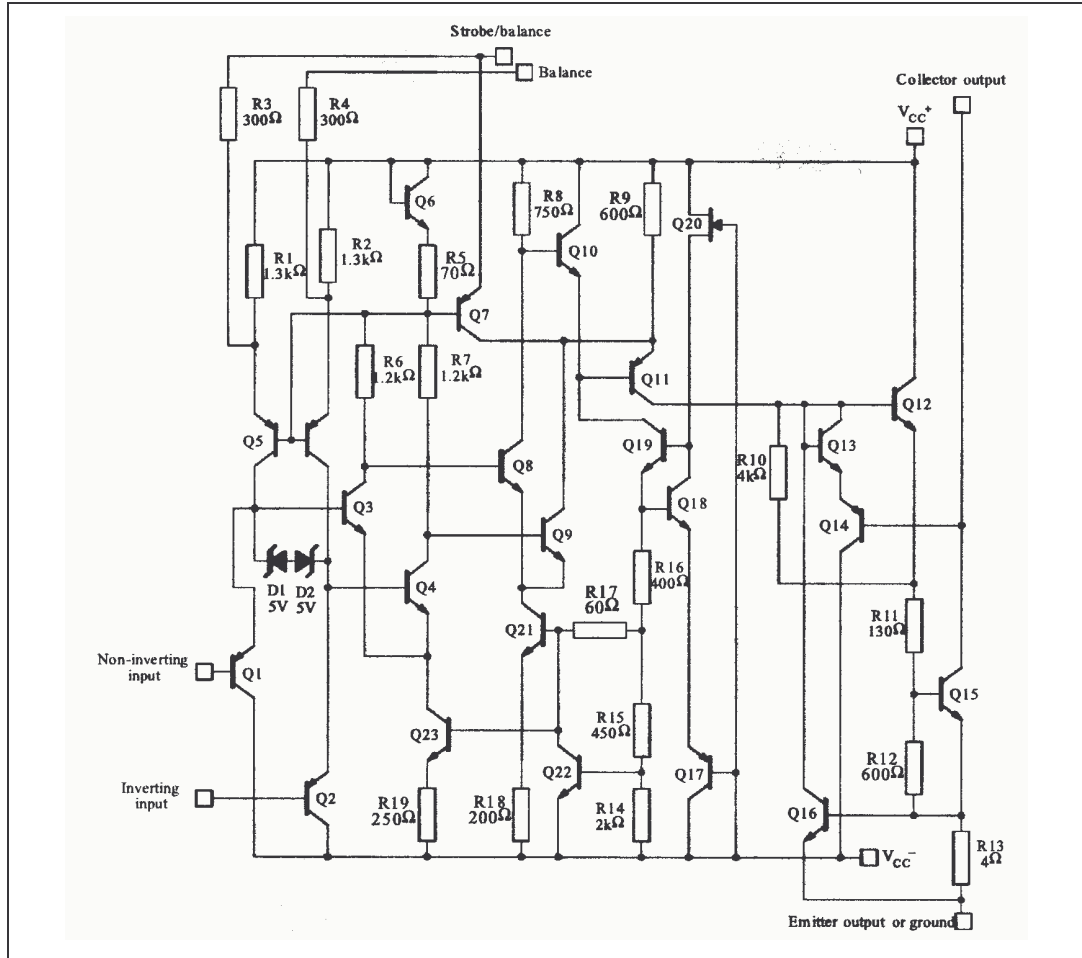

### 3 Electrical Characteristics

Table 3.  $V_{CC}^+ = \pm 15V$ ,  $T_{amb} = +25^\circ C$  (unless otherwise specified)

Symbol	Parameter	Conditions	LM111 - LM211			LM311			Unit
			Min.	Typ.	Max.	Min.	Typ.	Max.	
$V_{io}$	Input Offset Voltage <sup>(1)</sup>	$R_S \leq 50k\Omega$ $T_{amb} = +25^\circ C$ $T_{min} \leq T_{amb} \leq T_{max}$		0.7	3 4		2	7.5 10	mV
$I_{io}$	Input Offset Current see note 1)	$T_{amb} = +25^\circ C$ $T_{min} \leq T_{amb} \leq T_{max}$		4	10 20		6	50 70	nA
$I_{ib}$	Input Bias Current (see note 1)	$T_{amb} = +25^\circ C$ $T_{min} \leq T_{amb} \leq T_{max}$		60	100 150		100	250 300	nA
$A_{vd}$	Large Signal Voltage Gain		40	200		40	200		V/mV
$I_{CC}^+$ $I_{CC}^-$	Supply Currents	Positive Negative		5.1 4.1	6 5		5.1 4.1	7.5 5	mA
$V_{icm}$	Input Common Mode Voltage Range	$T_{min} \leq T_{amb} \leq T_{max}$	-14.5	+13.8 -14.7	+13	-14.5	+13.8 -14.7	+13	V
$V_{OL}$	Low Level Output Voltage	$T_{amb} = +25^\circ C$ , $I_O = 50mA$ , $V_i \leq -5mV$		0.75	1.5				V
		$T_{amb} = +25^\circ C$ , $I_O = 50mA$ , $V_i \leq -10mV$					0.75	1.5	
		$T_{min} \leq T_{amb} \leq T_{max}$ $V_{CC}^+ \geq +4.5V$ , $V_{CC}^- = 0$ $I_O = 8mA$ , $V_i \leq -6mV$		0.23	0.4				
		$T_{min} \leq T_{amb} \leq T_{max}$ $V_{CC}^+ \geq +4.5V$ , $V_{CC}^- = 0$ $I_O = 8mA$ , $V_i \leq -10mV$					0.23	0.4	
$I_{OH}$	High Level Output Current	$T_{amb} = +25^\circ C$ $V_i \geq +5mV$ , $V_o = +35V$		0.2	10				nA
		$T_{amb} = +25^\circ C$ $V_i \geq +10mV$ , $V_o = +35V$					0.2	50	nA
		$T_{min} \leq T_{amb} \leq T_{max}$ $V_i \geq +5mV$ , $V_o = +35V$		0.1	0.5				$\mu A$
<b>Istrobe</b>	Strobe Current			3			3		mA
<b>t<sub>re</sub></b>	Response Time <sup>(2)</sup>			200			200		ns

1. The offset voltage, offset current and bias current specifications apply for any supply voltage from a single +5V supply up to  $\pm 15V$  supplies. The offset voltages and offset currents given are the maximum values required to drive the output down to +1V or up to +14V with a 1mA load current. Thus, these parameters define an error band and take into account the worst-case of voltage gain and input impedance.

2. The response time specified (see definitions) is for a 100mV input step with 5mV overdrive.

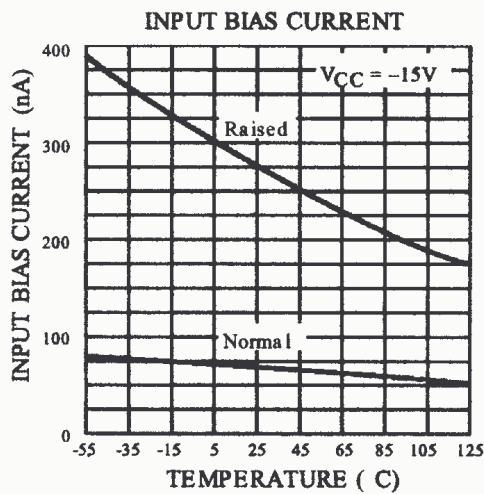
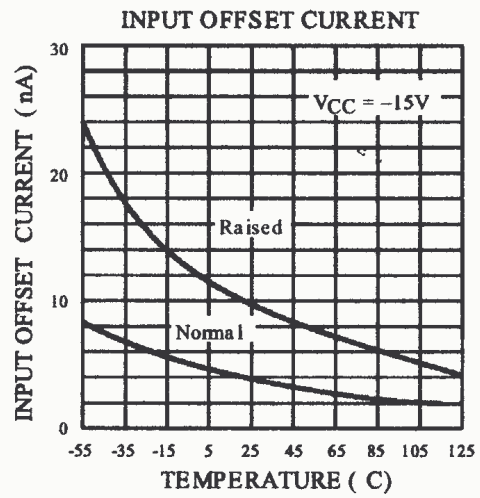
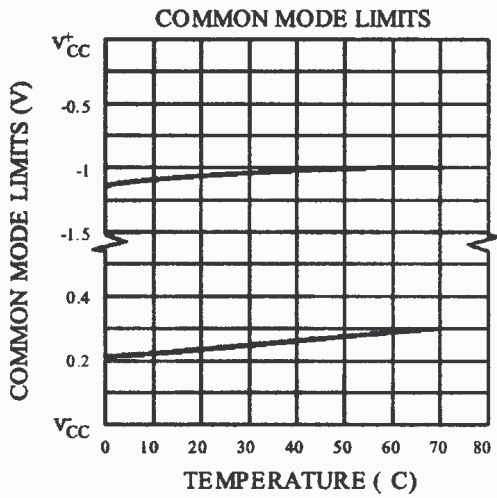
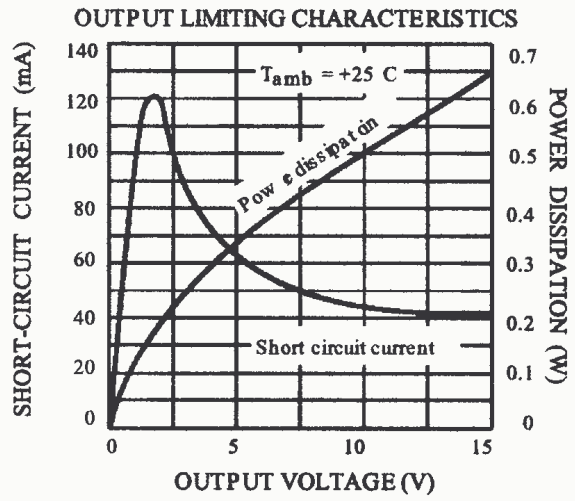
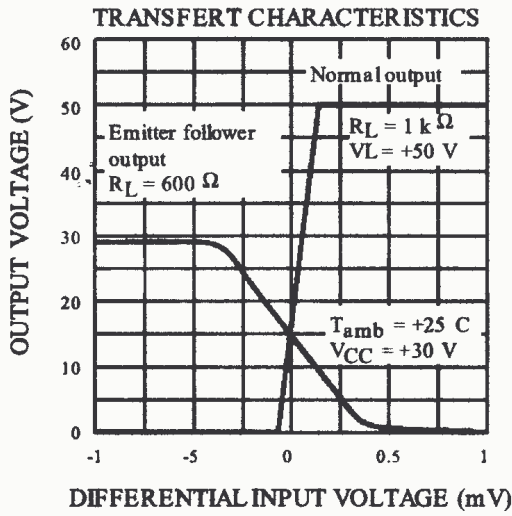

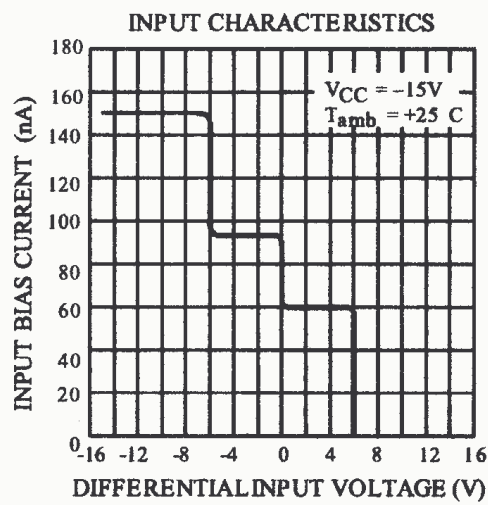
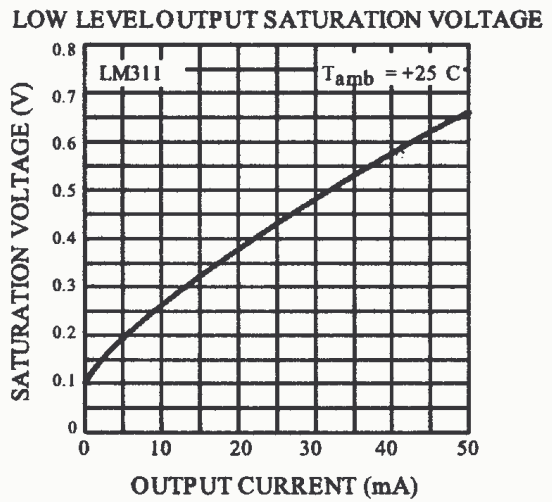
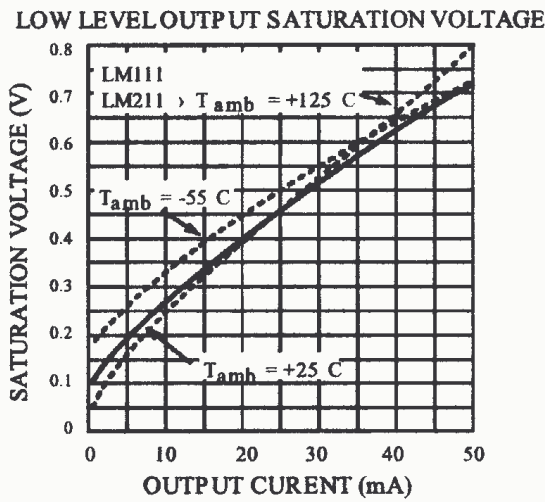
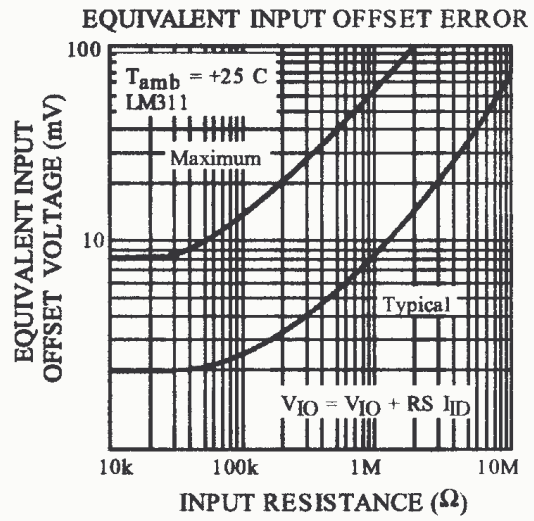
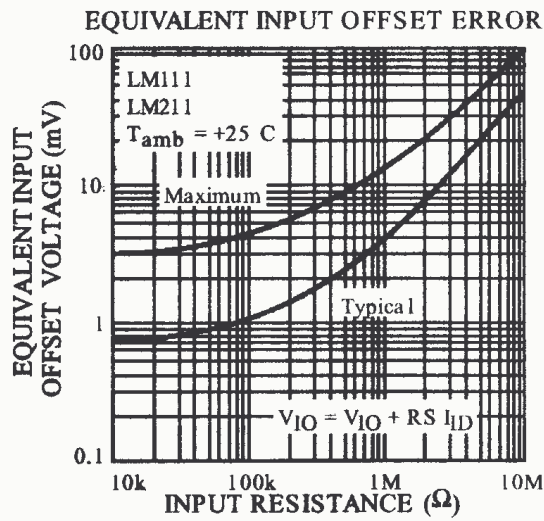

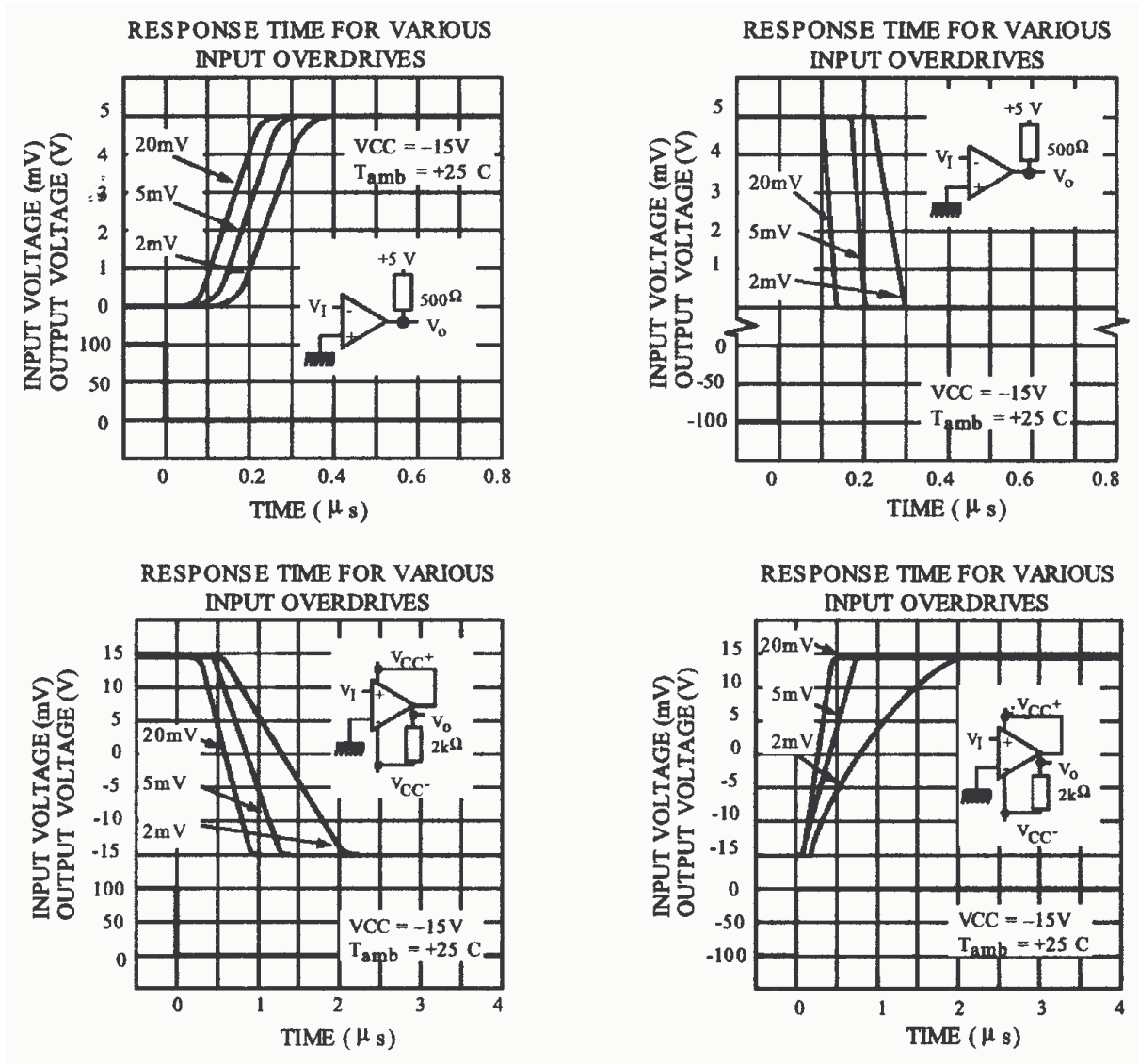

TYPICAL APPLICATIONS

CRYSTAL OSCILLATOR

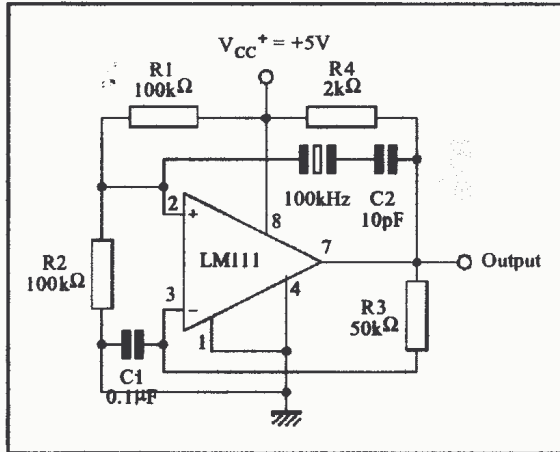

LOW VOLTAGE ADJUSTABLE REFERENCE SUPPLY

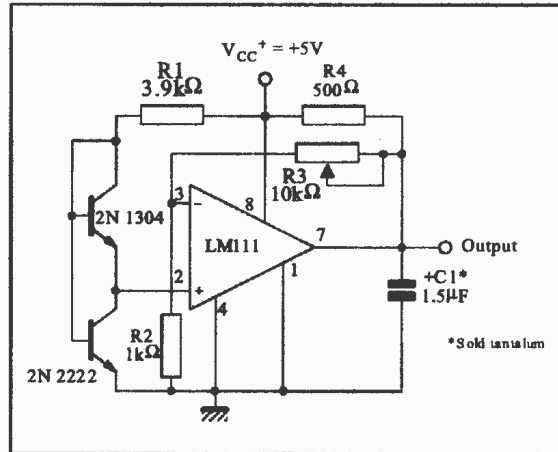

100kHz FREE RUNNING MULTIVIBRATOR

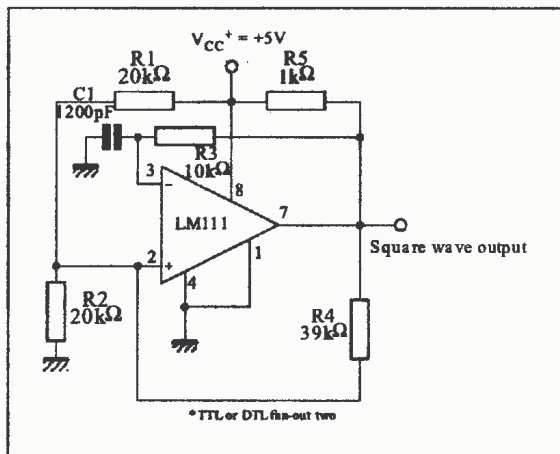

TTL INTERFACE WITH HIGH LEVEL LOGIC

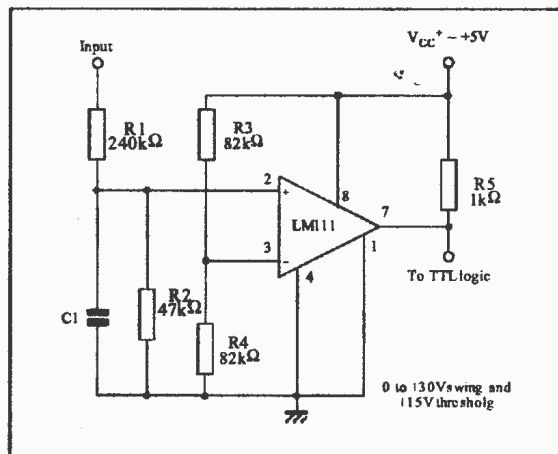

AUXILIARY CIRCUITS

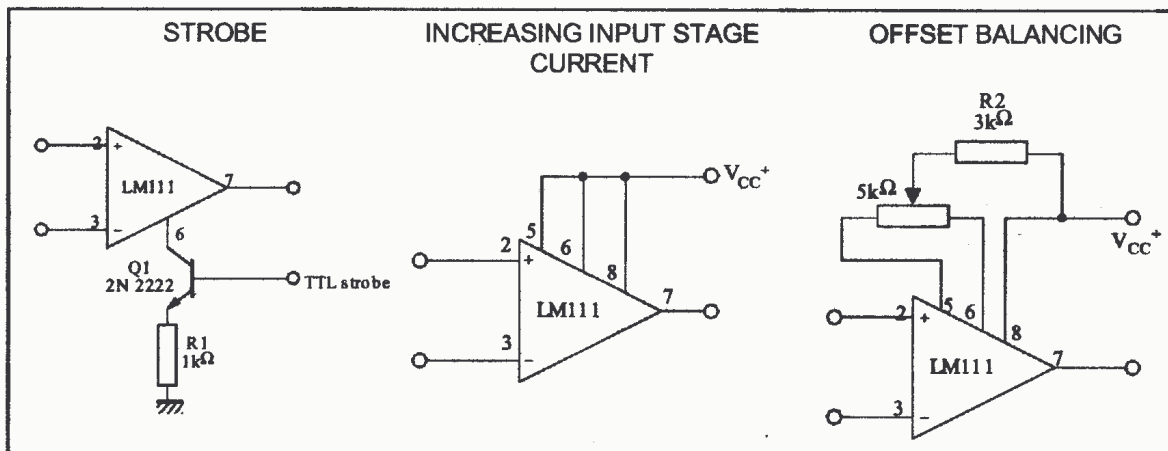



## 4 Package Mechanical Data

In order to meet environmental requirements, ST offers these devices in ECOPACK® packages. These packages have a Lead-free second level interconnect. The category of second level interconnect is marked on the package and on the inner box label, in compliance with JEDEC Standard JESD97. The maximum ratings related to soldering conditions are also marked on the inner box label. ECOPACK is an ST trademark. ECOPACK specifications are available at: [www.st.com](http://www.st.com).

### 4.1 DIP8 Package

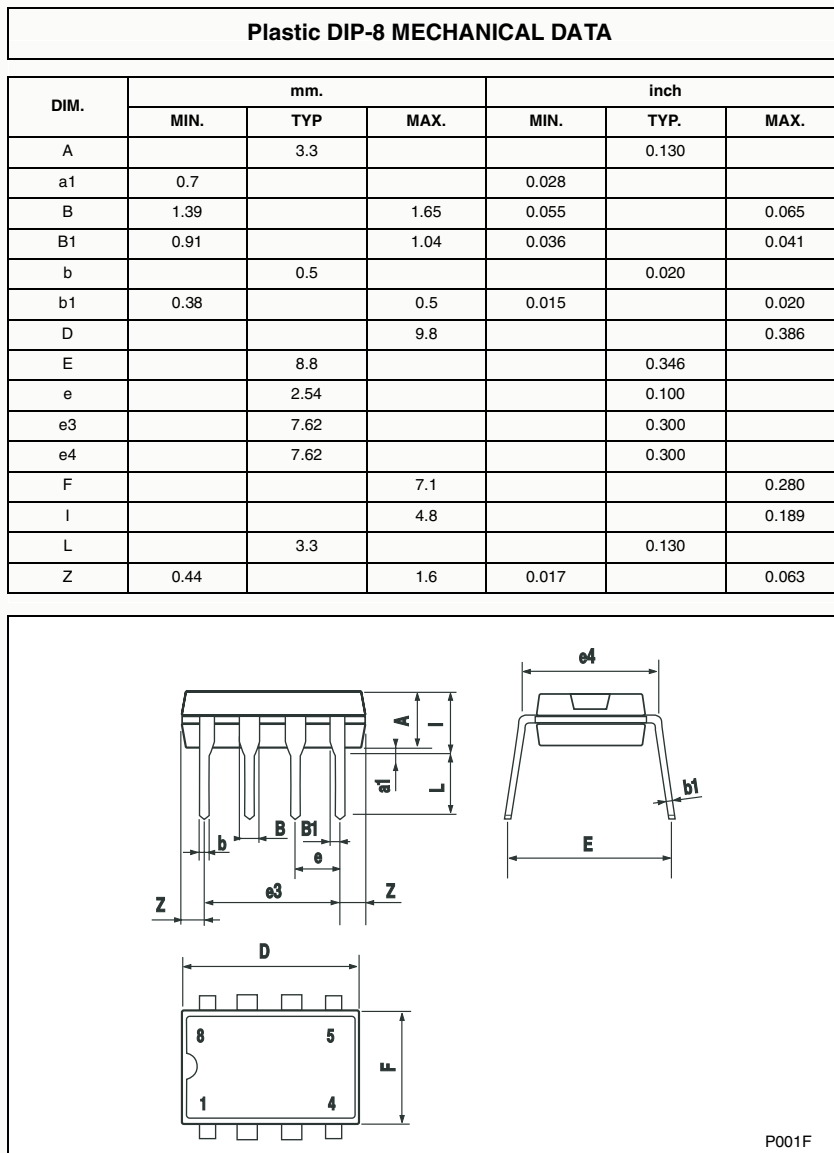

## 4.2 SO-8 Package

SO-8 MECHANICAL DATA						
DIM.	mm.			inch		
	MIN.	TYP.	MAX.	MIN.	TYP.	MAX.
A	1.35		1.75	0.053		0.069
A1	0.10		0.25	0.04		0.010
A2	1.10		1.65	0.043		0.065
B	0.33		0.51	0.013		0.020
C	0.19		0.25	0.007		0.010
D	4.80		5.00	0.189		0.197
E	3.80		4.00	0.150		0.157
e		1.27			0.050	
H	5.80		6.20	0.228		0.244
h	0.25		0.50	0.010		0.020
L	0.40		1.27	0.016		0.050
k	g <sup>+</sup> (max.)					
ddd			0.1			0.04

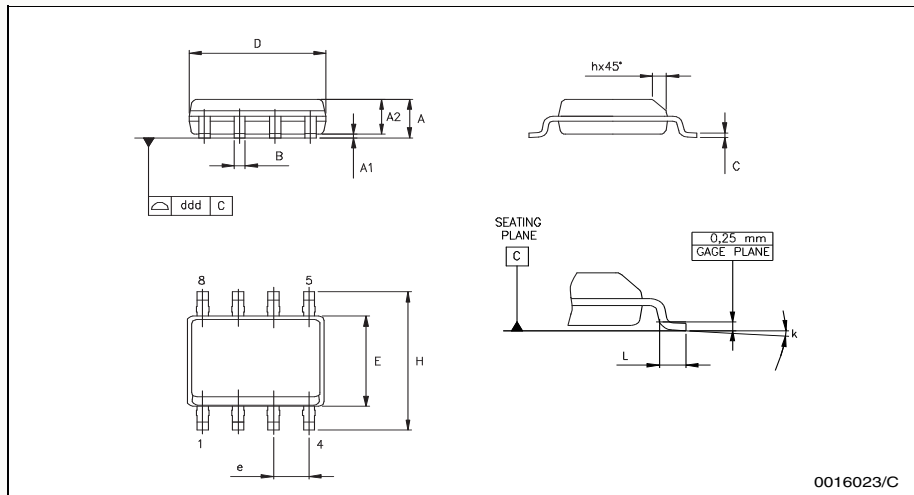

0016023/C

## 5 Revision history

**Table 4. Document revision history**

Date	Revision	Changes
June 2002	1	– Initial release.
Jan. 2006	2	– <i>Table 3. on page 4</i> updated. – Formatting changes throughout.
March 2006	3	– Pin connections updated on page 1.

**Please Read Carefully:**

Information in this document is provided solely in connection with ST products. STMicroelectronics NV and its subsidiaries ("ST") reserve the right to make changes, corrections, modifications or improvements, to this document, and the products and services described herein at any time, without notice.

All ST products are sold pursuant to ST's terms and conditions of sale.

Purchasers are solely responsible for the choice, selection and use of the ST products and services described herein, and ST assumes no liability whatsoever relating to the choice, selection or use of the ST products and services described herein.

No license, express or implied, by estoppel or otherwise, to any intellectual property rights is granted under this document. If any part of this document refers to any third party products or services it shall not be deemed a license grant by ST for the use of such third party products or services, or any intellectual property contained therein or considered as a warranty covering the use in any manner whatsoever of such third party products or services or any intellectual property contained therein.

**UNLESS OTHERWISE SET FORTH IN ST'S TERMS AND CONDITIONS OF SALE ST DISCLAIMS ANY EXPRESS OR IMPLIED WARRANTY WITH RESPECT TO THE USE AND/OR SALE OF ST PRODUCTS INCLUDING WITHOUT LIMITATION IMPLIED WARRANTIES OF MERCHANTABILITY, FITNESS FOR A PARTICULAR PURPOSE (AND THEIR EQUIVALENTS UNDER THE LAWS OF ANY JURISDICTION), OR INFRINGEMENT OF ANY PATENT, COPYRIGHT OR OTHER INTELLECTUAL PROPERTY RIGHT.**

**UNLESS EXPRESSLY APPROVED IN WRITING BY AN AUTHORIZE REPRESENTATIVE OF ST, ST PRODUCTS ARE NOT DESIGNED, AUTHORIZED OR WARRANTED FOR USE IN MILITARY, AIR CRAFT, SPACE, LIFE SAVING, OR LIFE SUSTAINING APPLICATIONS, NOR IN PRODUCTS OR SYSTEMS, WHERE FAILURE OR MALFUNCTION MAY RESULT IN PERSONAL INJURY, DEATH, OR SEVERE PROPERTY OR ENVIRONMENTAL DAMAGE.**

Resale of ST products with provisions different from the statements and/or technical features set forth in this document shall immediately void any warranty granted by ST for the ST product or service described herein and shall not create or extend in any manner whatsoever, any liability of ST.

ST and the ST logo are trademarks or registered trademarks of ST in various countries.

Information in this document supersedes and replaces all information previously supplied.

The ST logo is a registered trademark of STMicroelectronics. All other names are the property of their respective owners.

© 2006 STMicroelectronics - All rights reserved

STMicroelectronics group of companies

Australia - Belgium - Brazil - Canada - China - Czech Republic - Finland - France - Germany - Hong Kong - India - Israel - Italy - Japan - Malaysia - Malta - Morocco - Singapore - Spain - Sweden - Switzerland - United Kingdom - United States of America

[www.st.com](http://www.st.com)