

LOC		DIST		REVISIONS				
AD	00	P	LTR	DESCRIPTION	DATE	DWN	APVD	
		A1		REV PER ECO-11-004917	12MAR2011	RK	HMR	
		A2		REV PER ECR-17-018762	27DEC2017	ML	SZ	

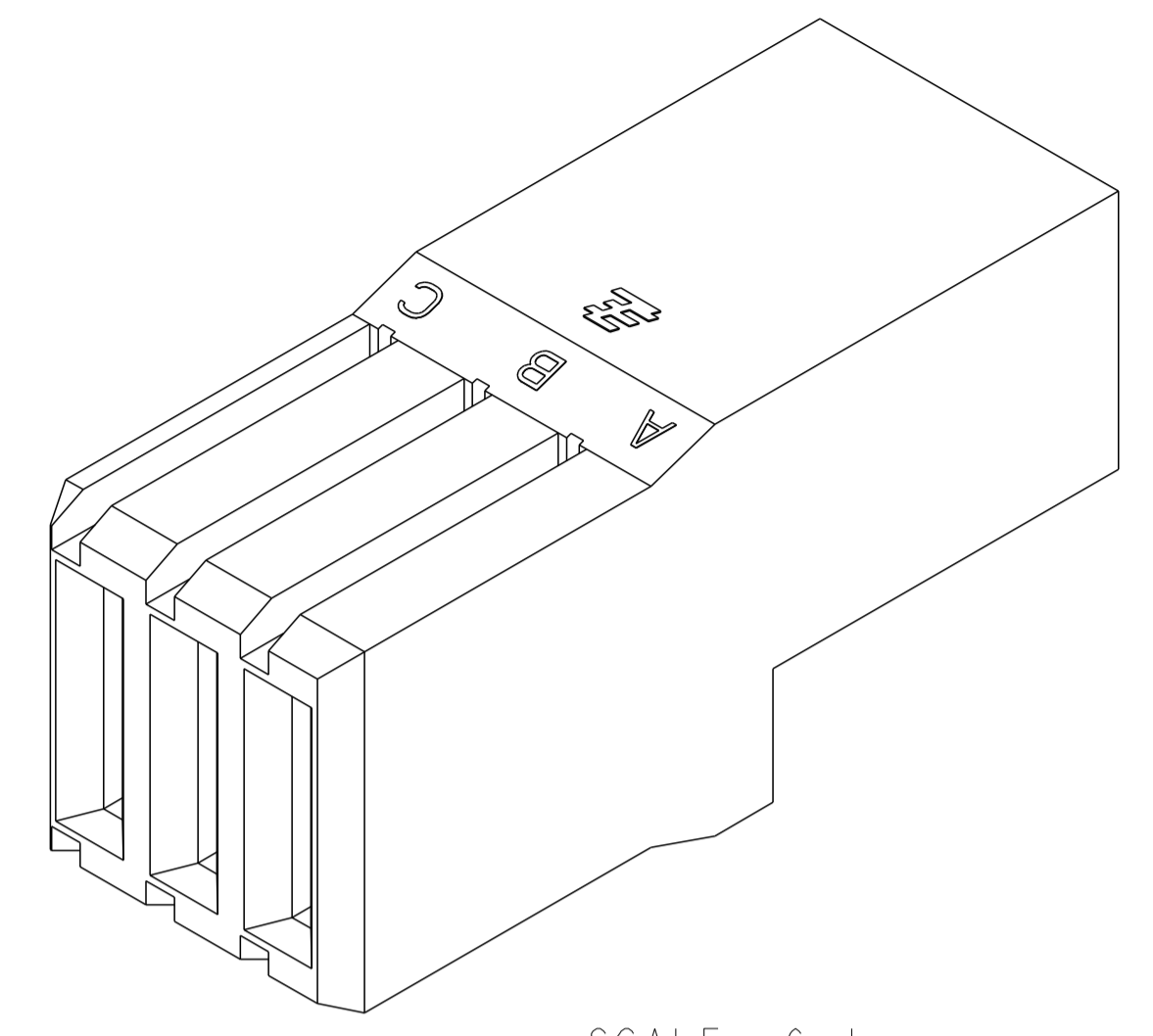

SCALE 6:1

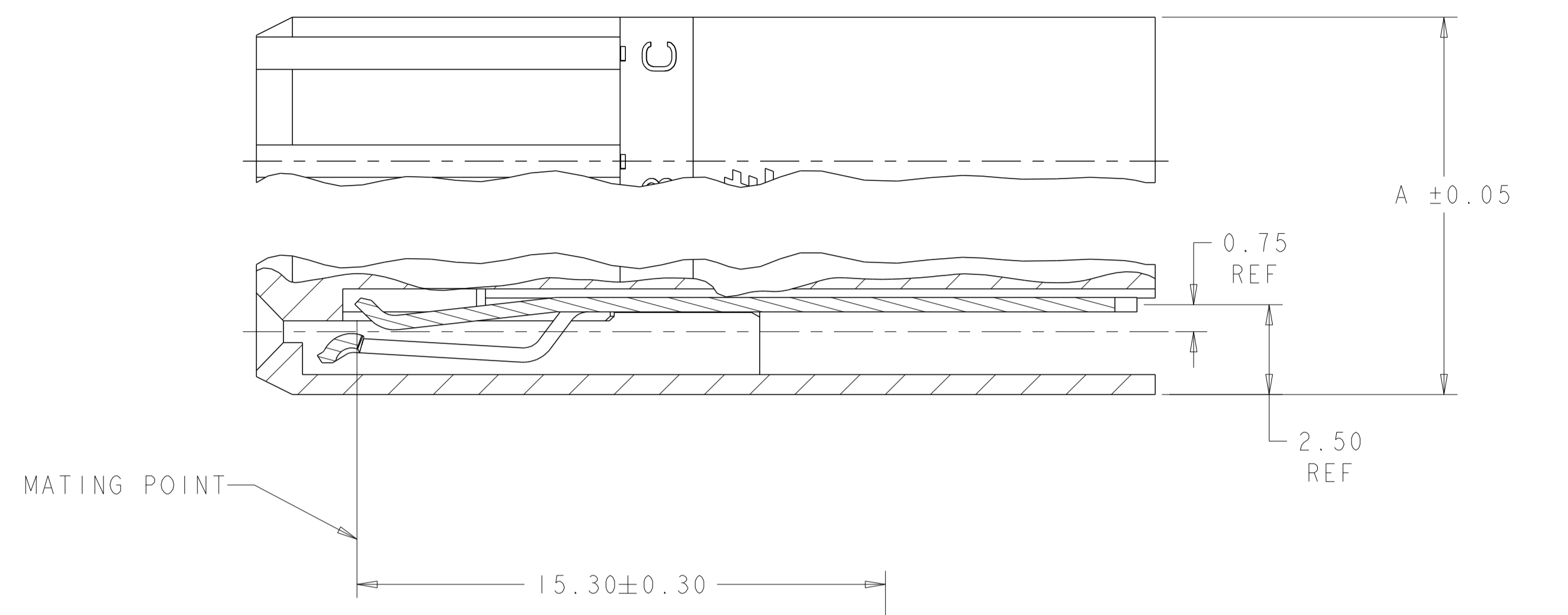
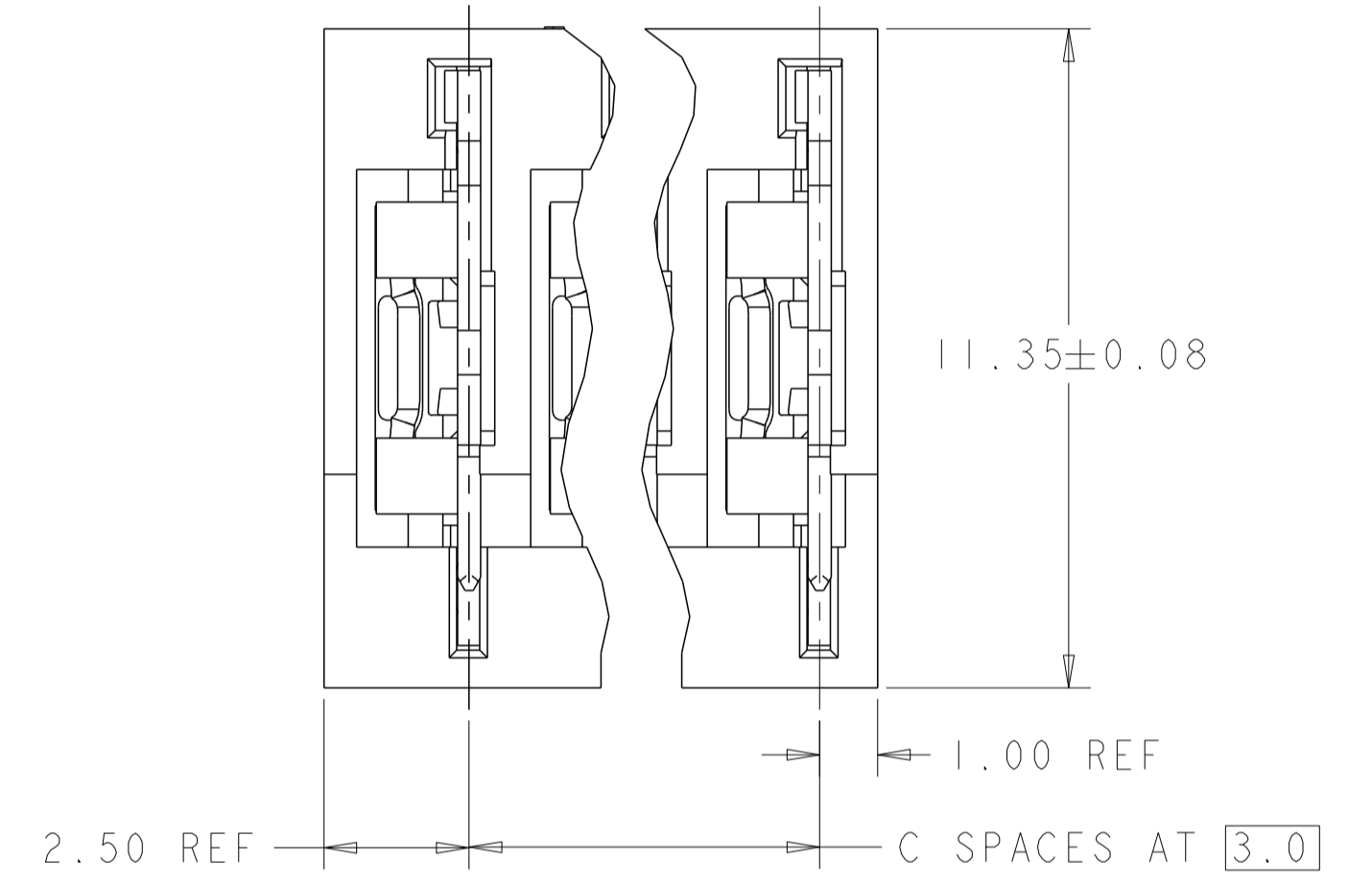
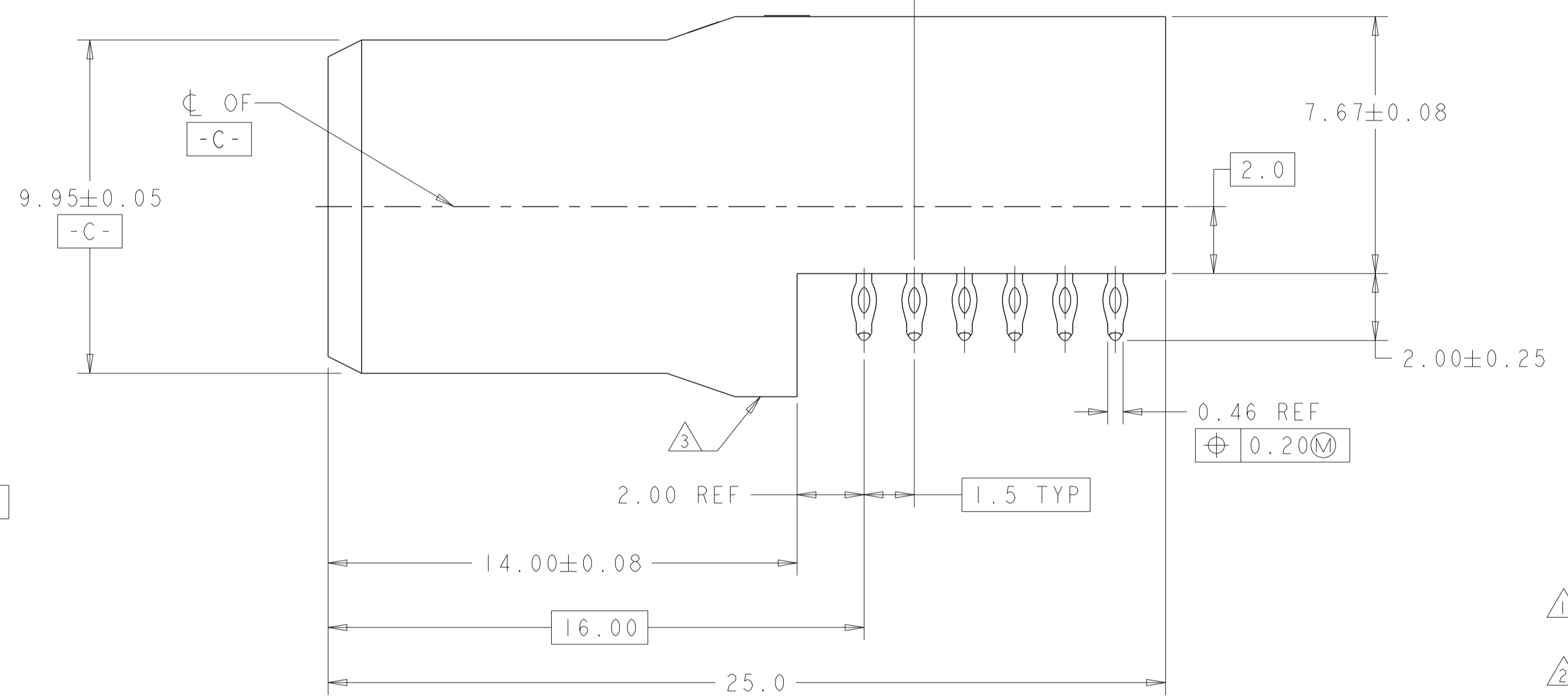
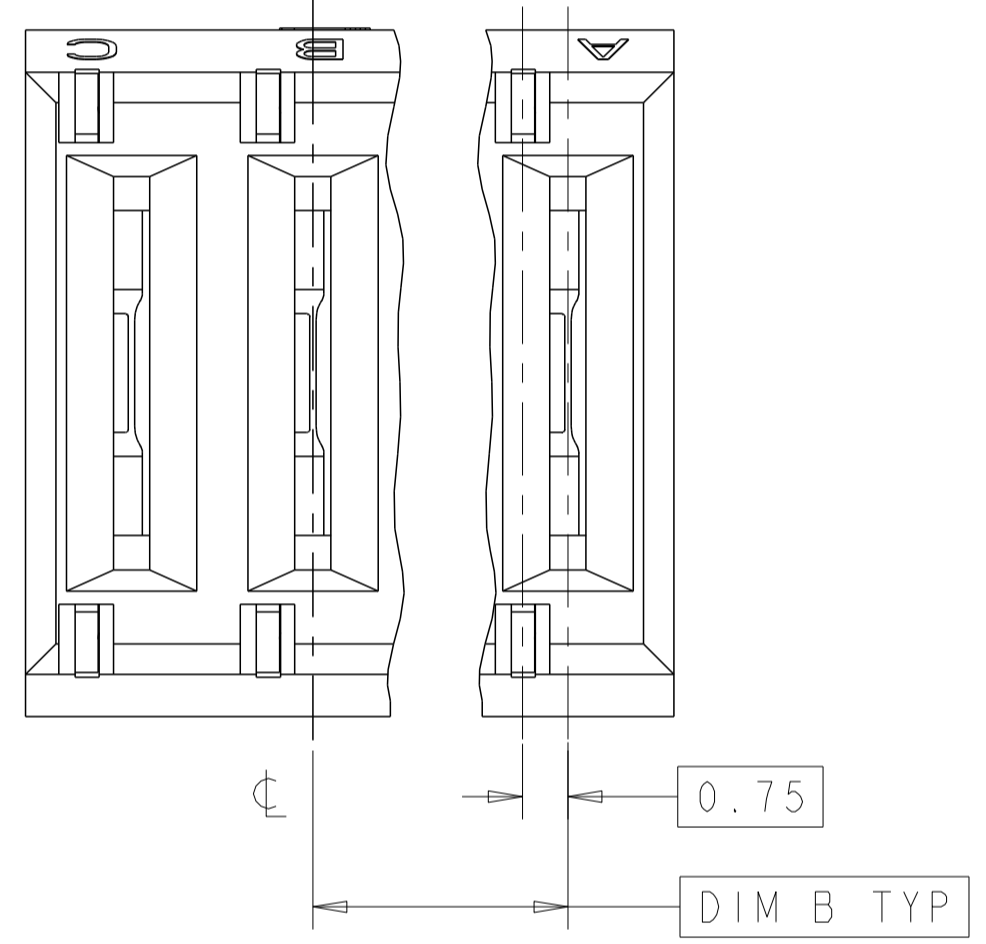

- △ HOUSING: POLYESTER, GRAY.
CONTACT: HIGH CURRENT COPPER ALLOY.
- △ CONTACT MATING AREA: 1.27µm MIN GOLD PLATE,
COMPLIANT PIN AREA: 0.5µm MIN MATTE TIN PLATE,
ALL OVER 1.27µm MIN NICKEL UNDERPLATE.
- △ DATE CODE THIS APPROXIMATE AREA.
- △ REFERENCE APPLICATION SPEC 114-1103 FOR RECOMMENDED
PLATED THRU HOLE DIAMETER & PLATING THICKNESSES.

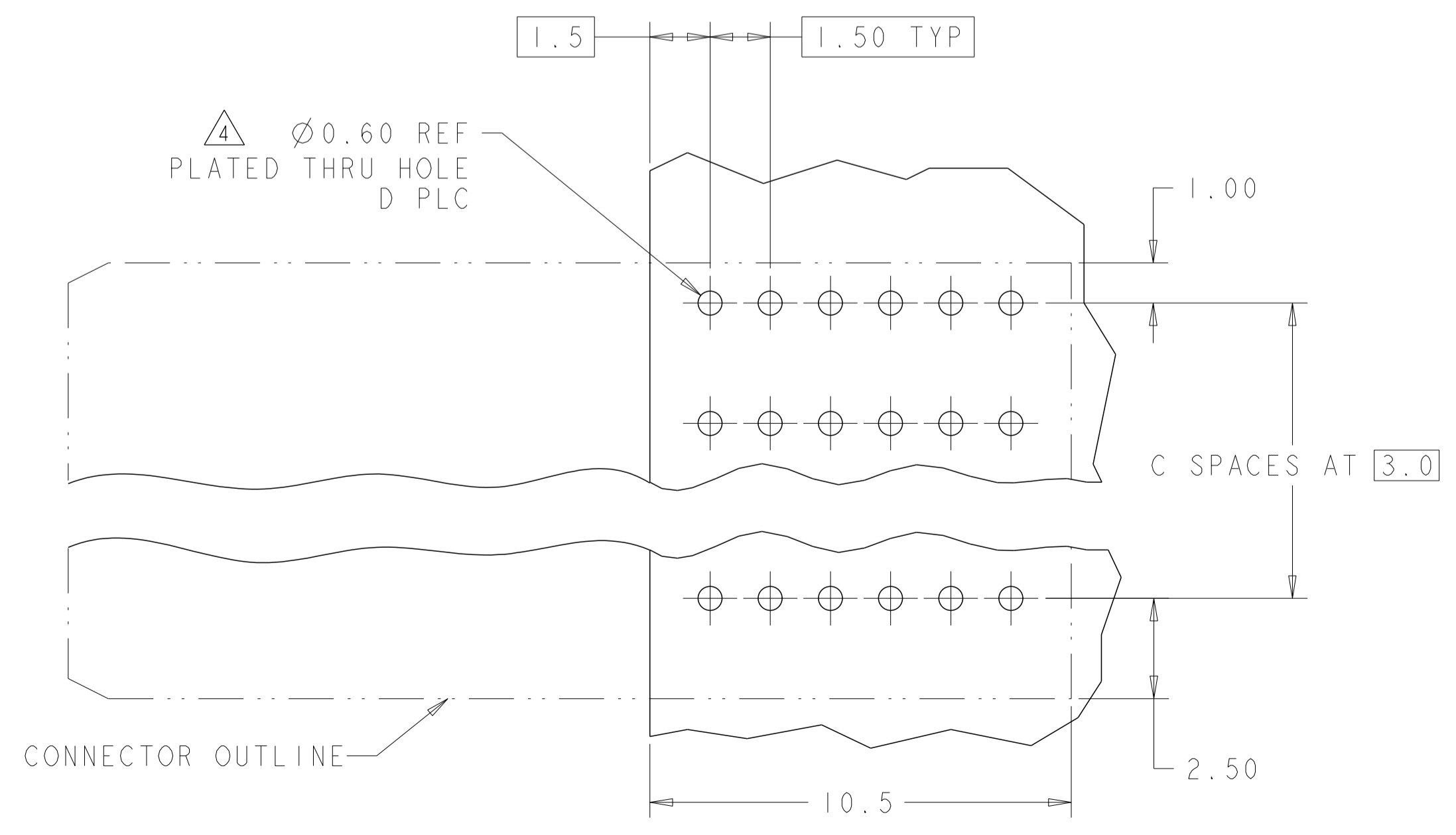

RECOMMENDED PCB HOLE LAYOUT

54	8	12.0	27.50	9	120943-7
48	7	10.5	24.50	8	120943-6
42	6	9.0	21.50	7	120943-5
36	5	7.5	18.50	6	120943-4
30	4	6.0	15.50	5	120943-3
24	3	4.5	12.50	4	120943-2
18	2	3.0	9.50	3	120943-1
D	C	B	A	POSN	PART NUMBER

THIS DRAWING IS A CONTROLLED DOCUMENT. DWN: B. CARBO 16JUN2005
 CHK: R. PATTERSON 16JUN2005
 APVD: R. PATTERSON 16JUN2005

STE TE Connectivity

ASSEMBLY, RIGHT ANGLE, RECEPTACLE, UNIVERSAL POWER MODULE

SIZE: CAGE CODE: DRAWING NO: 108-1651
 APPLICATION SPEC: 114-1103
 WEIGHT: -

MATERIAL: FINISH: CUSTOMER DRAWING

SCALE: 8:1 SHEET 1 OF 1 REV: A2

Mouser Electronics

Authorized Distributor

Click to View Pricing, Inventory, Delivery & Lifecycle Information:

[TE Connectivity:](#)

[120943-4](#)