

Principal Applications

Designed for transfer, demand/delivery, filtration, high flow booster, carbonation, beverage dispense & continuous reverse osmosis application

Features

New multi-chamber technology with patented valve design
overcomes vibration and hydraulic pulsation

Self-priming

Whisper Quiet

Energy efficient

AC and DC motor options

Alternative bypass pressures

Optional mounting orientation

Dry running without damage

Compatible with standard fittings

Corrosion and chemically resistant versions

AD550 Voltage Options

230V 1Ph 50/60Hz

110V 1Ph 50/60Hz

Drawings not to scale
 Dimensions in millimetres

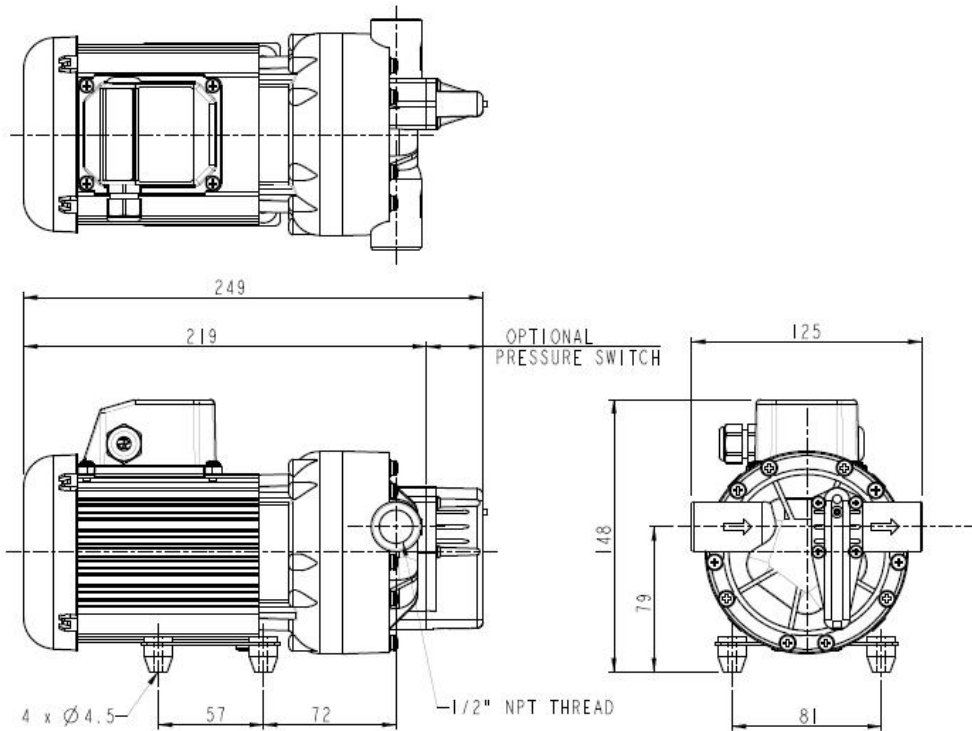

Specification

Model	Overall height (mm)	Overall length (mm)	Overall width (mm)	Weight (kg)	Max body pressure (bar)	Max capacity (l/min)	Max head (m)	Temp range (degC)	*Max specific gravity	Motor output (watts)
AD550	148	249	125	3.2	15	10	28	0-60	1.2	33

*Assuming maximum viscosity of 30cp. Refer to Totton Pumps for higher viscosities and specific gravities

Performance

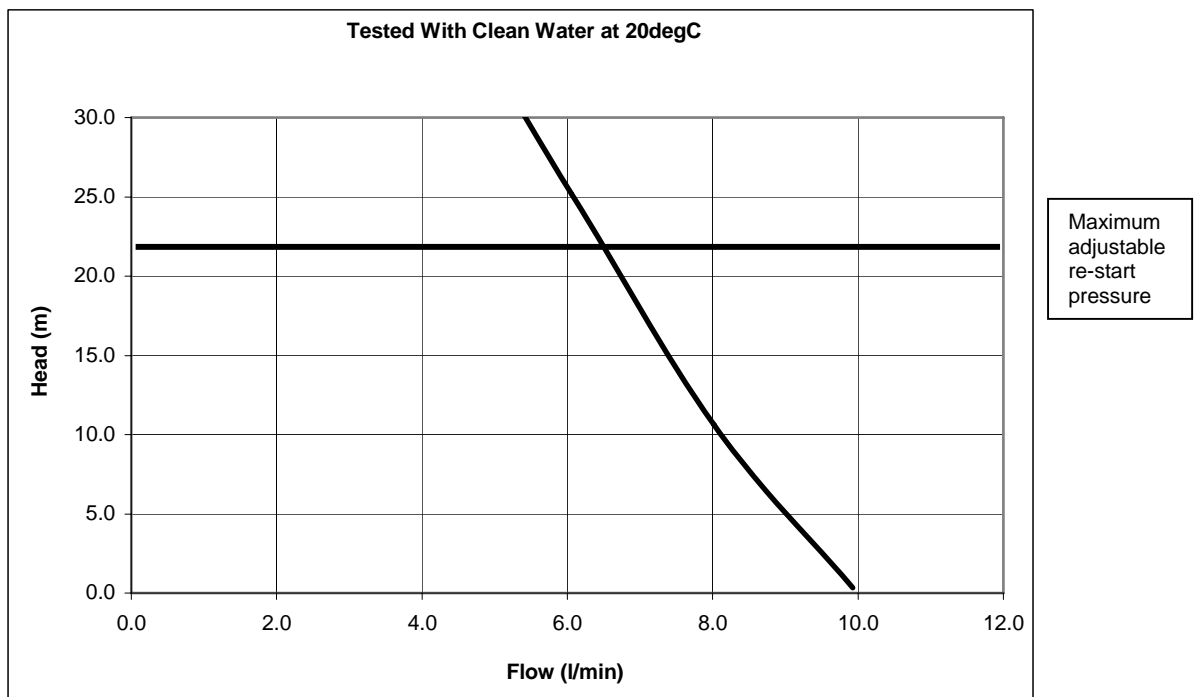

NOTE: These diaphragm pumps are designed for use with clean fluids.
 Solids will cause reduced performance and damage the pump.
 Abrasives will reduce pump life & invalidate the warranty.
 AD pumps are self-priming and can run dry for limited periods.
 The company reserves the right to change specifications.

Part List

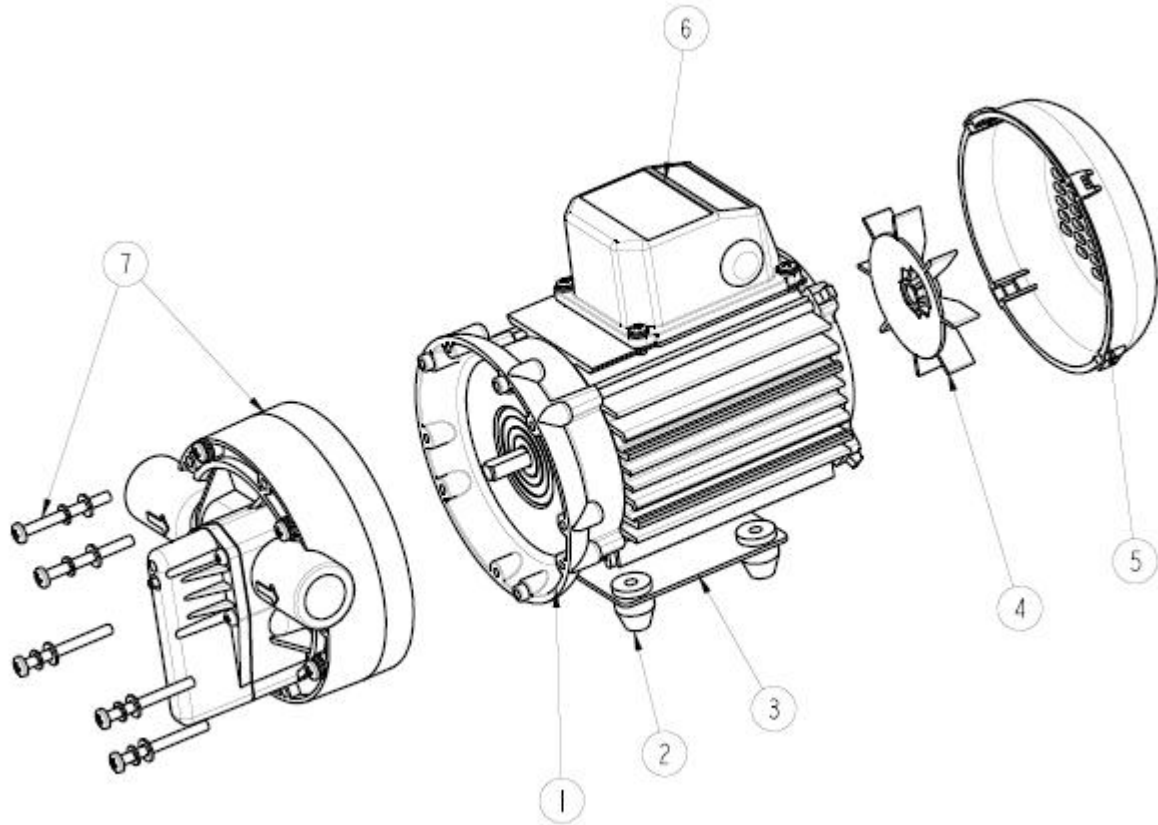

Item Number	Description	Quantity	Part Number	
1	Motor	1	116886 (230V)	116887 (110V)
2	Rubber Foot	1	022272	
3	Mounting Foot	1	036335	
4	Fan	1	001577	
5	Fan Cowl	1	036003 (2 Series Motor)	036085 (4 Series Motor)
6	Terminal Box	1	016153 (2 Series Motor)	036078 (4 Series Motor)
7	Pump Head	1	022873 (40psi Pressure Switch)	

Totton Pumps Ltd.

Tel: +44 (0)23 8066 6685

Fax: +44 (0)23 8066 6880

Email: info@totton-pumps.com

Web: www.totton-pumps.co.uk