

Streamline Series Vector Network Analyzer (B-models)

P937xB 2-port Up to 44 GHz

P938xB 4-port Up to 20 GHz

P500xB 2-port Up to 53 GHz

P502xB 4-port Up to 53 GHz / 6-port Up to 20 GHz

Compact form. Zero compromise.



Table of Contents

Keysight Streamline Series VNA	4
P93xxB and P50xxB Configurations	5
Test set options.....	6
Application software.....	6
Calibration option	9
Training options	9
Additional hardware	9
Accessories.....	10
Test cables.....	12
Measurement Application Software	13
Automatic fixture removal (S97007B).....	13
Time domain analysis (S97010B).....	13
Enhanced time domain analysis with TDR (S97011B).....	13
Real time S-parameter and power measurement uncertainty (S97015B).....	14
Basic Pulsed-RF measurements lite (S970240B/S970241B)	14
Basic Pulsed-RF measurements (S970250B/S970251B).....	14
Noise figure measurements with vector correction (S97029B)	15
Scalar mixer/converter measurements (S97082B).....	16
Vector and scalar mixer/converter measurements (S97083B).....	16
Embedded LO capability (S97084B)	16
Gain compression measurements (S97086B).....	17
Source phase control (S97088B).....	17
Differential and I/Q device measurements (S97089B)	17
Spectrum analysis (S97090xB)	18
True-mode stimulus (S97460B).....	18
Multiple instrument measurements (S97551B)	18
Multiport calibration assistant (S97552B)	19
Multiport calibrated measurements with switch instruments (S97553B)	19
Material measurements	20
N1930xB Physical Layer Test System (PLTS) Software.....	20
Device Measurement eXpert (DMX) (S94601B)	20
Limit assistant (S94602B).....	20
Automated measurement expert (AMX)	20
PathWave Vector Signal Analysis (89600 VSA) Software	21
Vector Network Analyzer (VNA) simulator (S9405xB).....	21
Direct Receiver Access (DRA) Configurations.....	22

DRA configuration with high-power	22
Keysight Software Licensing Options Provide Flexibility and Support	23
Choose your term. Choose your type. Keep control of your budget.	23
License term	23
License type.....	23
KeysightCare Software Support Subscription provides peace of mind amid evolving technologies.....	23
Ordering Information	24
Cable and adapter sets.....	25
Calibration kits	26
For devices with 1.85 mm connectors	27
For devices with 2.4 mm connectors	28
For devices with K connectors (2.92 mm)	29
For devices with 3.5 mm or SMA connectors	30
For devices with Type-N connectors	34
For devices with 7 mm connectors	38
For devices with waveguide.....	38
Verification kits.....	40
Accessories.....	41
PC Requirements for VNA control	42
Literature Information.....	42
Web Resources.....	42

Keysight Streamline Series VNA

The freedom of portable network analysis doesn't have to mean a compromise in performance. The B-models of the Keysight Streamline Series VNAs unlock the full performance of the network analyzer hardware with fast measurements over Thunderbolt 3 connections to your host PC. Gain confidence in your measurements with best-in-class performance offering fast, reliable, and repeatable results. Explore the complete characterization of your devices with a rich portfolio of software applications that transform the compact network analyzer into a complete RF measurement solution.



The P50xxB Series offers the performance required for testing passive components, amplifiers, mixers or frequency converters. The vector network analyzer (VNA) provides best-in-class key specifications such as dynamic range, measurement speed, trace noise and temperature stability. Choose from 2- or 4-port models up to 53 GHz, or 6-port models up to 20 GHz.

The P93xxB Series provides excellent performance in general-purpose network analysis for passive components. With software applications like enhanced time domain analysis with TDR and automatic fixture removal, you can easily characterize passive components with the same performance of a benchtop setup. Choose from 2-port models up to 44 GHz or 4-port models up to 20 GHz.

The Streamline Series utilizes the same measurement science as other Keysight VNAs such as the PNA, ENA and PXI VNA. A common software platform makes it easy to choose the right level of performance to match budget and measurement needs. This commonality guarantees measurement consistency, repeatability, and a common remote-programming interface across multiple instruments in R&D and manufacturing.

This configuration guide describes standard configurations, options, accessories, and compatible peripherals for the P93xxB and P50xxB Keysight Streamline Series vector network analyzer (VNA).

P93xxB and P50xxB Configurations

Model ¹	Description	Test port connectors
P937xB Series		
P9370B	9 kHz to 4.5 GHz, 2-port	3.5 mm (f)
P9371B	9 kHz to 6.5 GHz, 2-port	3.5 mm (f)
P9372B	9 kHz to 9 GHz, 2-port	3.5 mm (f)
P9373B	9 kHz to 14 GHz, 2-port	3.5 mm (f)
P9374B	9 kHz to 20 GHz, 2-port	3.5 mm (f)
P9375B	100 kHz to 26.5 GHz, 2-port	3.5 mm (f)
P9377B	100 kHz to 44 GHz, 2-port	2.4 mm (f)
P938xB Series		
P9382B	9 kHz to 9 GHz, 4-port	3.5 mm (f)
P9384B	9 kHz to 20 GHz, 4-port	3.5 mm (f)
P500xB Series		
P5000B	9 kHz to 4.5 GHz, 2-port	3.5 mm (f)
P5001B	9 kHz to 6.5 GHz, 2-port	3.5 mm (f)
P5002B	9 kHz to 9 GHz, 2-port	3.5 mm (f)
P5003B	9 kHz to 14 GHz, 2-port	3.5 mm (f)
P5004B	9 kHz to 20 GHz, 2-port	3.5 mm (f)
P5005B	100 kHz to 26.5 GHz, 2-port	3.5 mm (f)
P5006B	100 kHz to 32 GHz, 2-port	2.4 mm (f)
P5007B	100 kHz to 44 GHz, 2-port	2.4 mm (f)
P5008B	100 kHz to 53 GHz, 2-port	1.85 mm (f)
P502xB Series		
P5020B	9 kHz to 4.5 GHz, 4 or 6-port	3.5 mm (f)
P5021B	9 kHz to 6.5 GHz, 4 or 6-port	3.5 mm (f)
P5022B	9 kHz to 9 GHz, 4 or 6-port	3.5 mm (f)
P5023B	9 kHz to 14 GHz, 4 or 6-port	3.5 mm (f)
P5024B	9 kHz to 20 GHz, 4 or 6-port	3.5 mm (f)
P5025B	100 kHz to 26.5 GHz, 4-port	3.5 mm (f)
P5026B	100 kHz to 32 GHz, 4-port	2.4 mm (f)
P5027B	100 kHz to 44 GHz, 4-port	2.4 mm (f)
P5028B	100 kHz to 53 GHz, 4-port	1.85 mm (f)

1. The B-models of Keysight Streamline Series VNAs include: Thunderbolt 3 cable assembly for connection with a host PC (800-mm, P/N: 8121-3588), power supply (external AC-DC adapter, P/N: 0950-6128 for P937xB/P500xB, or P/N: 0950-6166 for P938xB/P502xB), and power cord.

Test set options

Choose one of the frequency models, and one test set option for the P500xB or P502xB Series. Option 200 indicates two test ports, option 40x indicates four test ports and option 600 indicates six test ports. To add options to a product, order the corresponding item number (ex. P5000B-200).

Option number	2-port	4-port	6-port	Additional information
Option 200	X			Not available with P937xB, P938xB or P502xB Series.
Option 400		X		Not available with P937xB, P938xB or P500xB Series.
Option 402		X		Adds internal second source. Not available with P937xB, P938xB or P500xB Series.
Option 600			X	Not available with P937xB, P938xB or P500xB Series.

Application software

Description ^{1,2}	For P937xB, P938xB Series	For P500xB, P502xB Series	Additional information
Automatic fixture removal	S97007B	S97007B	
Time domain analysis	S97010B	S97010B	
Enhanced time domain analysis with TDR	S97011B	S97011B	Includes all capabilities of S97010B.
Real-time S-parameter and power measurement uncertainty	N/A	S97015B	Displays the measurement uncertainty dynamically (real-time) on the measurement trace.
Basic pulsed-RF measurements lite, up to 20 GHz ³	N/A	S970240B	Available with P5000B to P5004B, or P5020B to P5024B. Subset of S970250B.
Basic pulsed-RF measurements lite, up to 53 GHz ³	N/A	S970241B	Available with P5005B to P5008B, or P5025B to P5028B. Subset of S970251B.
Basic pulsed-RF measurements, up to 20 GHz ³	N/A	S970250B	Available with P5000B to P5004B, or P5020B to P5024B.
Basic pulsed-RF measurements, up to 53 GHz ³	N/A	S970251B	Available with P5005B to P5008B, or P5025B to P5028B.
Noise figure measurements with vector correction	N/A	S97029B	Standard receivers are used.
Scalar mixer/converter measurements ⁴	S97082B	S97082B	Provides SMC measurement class.
Vector and scalar mixer/ converter measurements ⁴	N/A	S97083B	Provides SMC + phase measurement class. Provides vector mixer characterization.
Embedded-LO capability ⁴	N/A	S97084B	
Gain-compression measurements ⁴	N/A	S97086B	
Source phase control	N/A	S97088B	Requires option 402 (internal second source option) or multiple instrument measurements with S97551B.
Differential and I/Q device measurements ⁴	N/A	S97089B	Requires option 402 (internal second source option) or multiple instrument measurements with S97551B.
Spectrum analysis, up to 4.5 GHz ^{4,5}	N/A	S970900B	Available with P5000B or P5020B.

Spectrum analysis, up to 6.5 GHz ^{4,5}	N/A	S970901B	Available with P5001B or P5021B.
Spectrum analysis, up to 9 GHz ^{4,5}	N/A	S970902B	Available with P5002B or P5022B.
Spectrum analysis, up to 14 GHz ^{4,5}	N/A	S970903B	Available with P5003B or P5023B.
Spectrum analysis, up to 20 GHz ^{4,5}	N/A	S970904B	Available with P5004B or P5024B.
Spectrum analysis, up to 26.5 GHz ^{4,5}	N/A	S970905B	Available with P5005B or P5025B.
Spectrum analysis, up to 32 GHz ^{4,5}	N/A	S970906B	Available with P5006B or P5026B.
Spectrum analysis, up to 44 GHz ^{4,5}	N/A	S970907B	Available with P5007B or P5027B.
Spectrum analysis, up to 44 GHz ^{4,5}	N/A	S970908B	Available with P5008B or P5028B.
True-mode stimulus	N/A	S97460B	Requires option 402 or multiple instruments measurements with S97551B.
Multiple instruments measurements	S97551B	S97551B	Provides multipoint calibrated measurements using two Streamline Series VNAs ^{6,7,8}
Multipoint calibration assistant	S97552B	S97552B	Provides a tool to flexibly define cal sets of multipoint measurements. Requires one ECal module.
Multipoint calibrated measurements with switch instruments	S97553B	S97553B	Provides multipoint calibrated measurements using P9164A/B or P9165A/B USB Solid-State Switch matrix ⁹
Vector Network Analyzer (VNA) simulator - Standard	S94050B	S94050B	Runs on your PC and simulates standard S-parameter measurement class of Keysight's VNAs.
Vector Network Analyzer (VNA) simulator - Advanced	S94051B	S94051B	Runs on your PC and simulates VNA functions including advanced features of S97xxxB software ¹⁰
Device measurement expert (DMX)	S94601B	S94601B	Assists the users in setting up measurements automatically with customizable templates.
Limit assistant	S94602B	S94602B	Allows to acquire the data from the VNA, and easily generate limit masks for production tests.
Automated measurement expert (AMX)	S94701A S94702A KS8400A	S94701A S94702A KS8400A	A smart software solution for automated S-parameter measurements with the Streamline Series VNA. Order each software model and install in a host PC.

1. S97xxxB and S97xxxB offer the same functionalities.
2. Refer to "Keysight Software Licensing Options Provide Flexibility and Support" for more detail about S97xxxB licenses.
3. Enables internal pulse generators and pulse modulators on the analyzer's source(s). Hardware options are not needed for pulsed-RF measurements.
4. Provides frequency offset mode (FOM) to independently set the frequency of internal source(s) and receivers, and to configure external sources using External Device Configuration.
5. Enables spectrum analysis and vector signal analysis using the VNA's receivers. PathWave Vector Signal Analysis (89600 VSA) software is required for vector signal analysis. Hardware options are not needed for spectrum analysis or vector signal analysis.
6. When configuring a multipoint VNA using multiple Streamline Series VNAs, the Y1701A is recommended for each additional multipoint interconnection.
7. P937xB and P938xB, or P500xB and P502xB can be combined in multipoint configurations. P93xxxB and P50xxxB Series cannot be combined.
8. A 4-port ECal module (i.e. N4431/32/33D) is recommended for multipoint measurements ($n > 4$).
9. Only the 4-port ECal modules (i.e. N4431/32/33D) are supported for calibration with S97553B.
10. Features of S97007B, S97552B and S97553B are not supported with the S94051B.

P93xxB option

VNA activation software option (option 001) enables basic VNA functionalities of P937xB and P938xB. It ensures compatibility with newly added features and keeps your instrument up to date.

1. Option 001 for P937xB and P938xB (ex. P9370B-001) installs node-locked, perpetual license of S9724xB-1FP in P937xB (x = 0 to 5, or 7) or S9725xB-1FP in P938xB (x = 2 or 4). This option is mandatory at the time of purchase of P937xB and P938xB Streamline Series VNA.

P50xxB software

S9720xB/S9721xB software improves measurement performance of P500xB and P502xB (ex. dynamic range, noise floor, max output power or cycle time) compared to the performance of P937xB and P938xB.

S9722xB/S9723xB software enables basic VNA functionalities of P500xB and P502xB. The software ensures compatibility with newly added features and keeps your instrument up to date.

Description	P500xB	P502xB
High-performance enabling software ¹	S9720xB	S9721xB
VNA activation software ¹	S9722xB	S9723xB

1. S972xxB software includes node-locked, perpetual license and one-year support subscription. It is mandatory at the time of purchase of P500xB or P502xB Streamline Series VNA (x = 0 to 8).

Performance comparison between P50xxB and P93xxB ^{1,2}

Performance		P50xxB	P93xxB
Dynamic range (10 Hz IFBW)	4 GHz	140 dB	115 dB
	20 GHz	126 dB	105 dB
Noise floor (10 Hz IFBW)	4 GHz	-130 dBm	-107 dBm
	20 GHz	-122 dBm	-101 dBm
Max output power	4 GHz	+10 dBm	+8 dBm
	20 GHz	+4 dBm	+4 dBm
IF bandwidth		1 Hz to 15 MHz	1 Hz to 700 kHz
Cycle time (2-port cal, 0.8 to 1 GHz. Typical)	201 points	1.8 ms (1 MHz IFBW)	15 ms (700 kHz IFBW)
	401 points	2.5 ms (1 MHz IFBW)	28 ms (700 kHz IFBW)

1. Refer to data sheet ([3121-1235.EN](#)) for more details about the difference in performance/specifications between P50xxB and P93xxB.

2. Refer to VNA selection guide ([5989-7603EN](#)) for the comparison of P50xxB and P50xxA, or P93xxB and P937xA.

Calibration option

Option number	Description	Additional information
Option 1A7	ISO 17025 compliant calibration	Provides a complete set of measurements which test the unit to manufacturer's published specifications. Includes calibration label, ISO 17025 calibration certificate and data report, and measurement uncertainties and guardbands on all customer specifications. Conforms to ISO 17025 and ISO 9001.

Training options

Description	For P937xB, P938xB Series	For P500xB, P502xB Series	Additional information
Included - instrument care and operations starter training	N/A	PS-S40-01	Provides startup training service that reduces complexity associated with initial setup and enables users to get to measurements fast. Recommended topics are product overview, system setup and initial measurements. Can be delivered remotely or on-site.
Optional - technology and measurement science standard training	N/A	PS-S40-02	Provides customized technology and measurement science training. Enable users to get deeper insights into the VNA measurement theory and applications. Recommended topics are VNA theory and applications. Can be delivered on-site or in Keysight office.
Optional - premium functional and customer specific application training	N/A	PS-S40-03	Provides an integrated training experience that fits to the users' needs on applications or workflow. Custom topics based on the user needs. Discuss the training needs with the Keysight sales representative.

Additional hardware

Model number	Description	Additional information
P9164A	Solid-state switch matrix module, 2x16 full crossbar, 300 kHz to 6.5 GHz	S97553B application software is required for multipoint calibrated measurements.
P9164B	Solid-state switch matrix module, 2x16 full crossbar, 300 kHz to 9 GHz	
P9165A	Solid-state switch matrix module, 2x8 full crossbar, 300 kHz to 6.5 GHz	
P9165B	Solid-state switch matrix module, 2x8 full crossbar, 300 kHz to 9 GHz	

Accessories

Description	For P937xB or P500xB Series	For P938xB or P502xB Series	Additional information
Rack mount kit	Y1700A-001	Y1700A-002	Order Option 001 for 2-port VNA (P937xB or P500xB Series). Order Option 002 for 4 or 6-port VNA (P938xB or P502xB Series).
Multiple USB instruments configuration kit	Y1701A-002 or 003	Y1701A-002 or 003	Includes interconnect cables for configurations using two VNAs ¹ . Add one kit for each additional VNA.
	Y1701A-101	Y1701A-202	Includes latch kit for connecting two instruments ² .
	Y1701A-302	Y1701A-303 or 304	Includes interconnect cables for multiport configurations in a rack ³ . Add one kit for each additional VNA.
	Y1701A-400 or 401	Y1701A-400 or 401	Includes Thunderbolt 3 cable assembly with USB Type-C connectors for connection with a host PC. ⁴
Hard transit case	Y1710A	Y1710A	
PXI adapter module ^{5,6}	Y1731A-001	Y1731A-001	Includes one PXI module to enable coaxial connections with control signals of Streamline Series VNA. Equipped with twelve SMB connectors. Includes 2 flexible control cables (500 mm and 175 mm) for connection with a control port of the VNA.
SMB (f) to MCX (m) cable assembly	Y1730A-800 or 801	Y1730A-800 or 801	For connection with 10 MHz external reference ports (Ref In/Ref Out) on the front panel of Streamline Series VNA ⁷ . Option 800 includes one 300-mm cable and option 801 includes one 1000-mm cable.
BNC (f) to MCX (m) cable assembly	Y1730A-810	Y1730A-810	For connection with 10 MHz external reference ports (Ref In/Ref Out) on the front panel of Streamline Series VNA ⁷ .

1. Order Y1701A Option 002 for P93xxB or P50xxB Series up to 20 GHz. Order Y1701A Option 003 for greater than 20 GHz models.

2. If 2-port VNA (ex. P500xB) and 4- or 6-port VNA (ex. P502xB) are connected for a multiport VNA, order Y1701A Option 102 latch kit for connecting 1-slot to 2-slot instruments.

3. Order Y1701A Option 302 for 2-port VNA (P937xB or P500xB Series). Order Option 303 for P938xB or P502xB-400/600 up to 20 GHz. Order option 304 for P502xB-400 (above 20 GHz) or P502xB-402 (all models).

4. Y1701A Option 400 includes one 500-mm cable (P/N: 8121-3587) and one retainer (P/N: P5000-29001). Option 401 includes one 800-mm cable (P/N: 8121-3588) and one retainer (P/N: P5000-29001).

5. Y1731A does not require power supply. PXI chassis is not needed for the operation.

6. Order Y1731A Option 800 (BNC (m) to SMB (f) cable assembly, 1000 mm) for connection with BNC connectors on external peripherals (ex. pulse generators)

7. Using 10 MHz reference ports (10 MHz In/Out) on the rear panel of Streamline Series VNA is not supported.



Figure 1. Rack mount kit for Keysight Streamline Series products (Y1700A option 001)



Figure 2. Transit case for Keysight Streamline Series products (Y1710A)



Interconnect cables
(Y1701A option 002)

Figure 3. Multiple instruments configuration kit (Y1701A)

Test cables

Option number	Description	Additional information
Y1740A-100	Cable Assembly, 3.5 mm (m) to 3.5 mm (m), 26.5 GHz, 36 inch	
Y1740A-200	Cable Assembly, 2.92 mm (m) to 2.92 mm (m), 40 GHz, 36 inch	
Y1740A-300	Cable Assembly, 2.4 mm (m) to 2.4 mm (m), 50 GHz, 36 inch	
Y1740A-310	Cable Assembly, 2.4 mm (m) to 2.92 mm (m), 40 GHz, 36 inch	
Y1740A-400	Cable Assembly, 1.85 mm (m) to 1.85 mm (m), 67 GHz, 1 m	

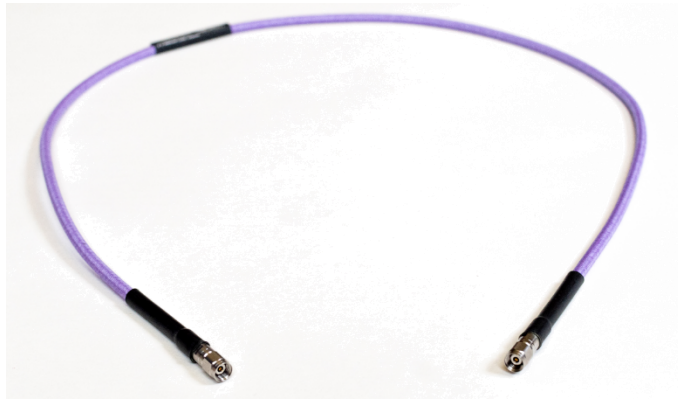

Figure 4. Cable assembly with 2.4-mm male connectors (Y1740A-300)

Measurement Application Software

Solid black series name indicates the feature is available on that series, while gray series name with strikethrough indicates the feature is not available with that series. For example:

P50xxB Series: Available with P500xB or P502xB Series

~~P93xxB Series~~: Not available with P937xB or P938xB Series

Automatic fixture removal (S97007B)

P93xxB Series

P50xxB Series

Many devices do not have coaxial connectors and are put in fixtures in order to measure them in a coaxial environment. Accurately removing the effects of the fixture is required to get a good measurement of the device under test (DUT). This application adds a powerful application wizard to guide you through characterizing a fixture and removing it from the measurement. Devices can be single-ended or differential. Files can be saved in a variety of formats for later use in ENA, PNA, PXI VNA, Streamline Series VNA, ADS, and PLTS.

Time domain analysis (S97010B)

P93xxB Series

P50xxB Series

This application enables the analyzer to view reflection and transmission responses in time or distance. Use time domain to tune filters, gate out the response of fixtures and cables, characterize the impedance of transmission lines and more.

Enhanced time domain analysis with TDR (S97011B)

P93xxB Series

P50xxB Series

This application enables the analyzer to perform enhanced time domain analysis for high-speed data applications. All functionality of the S97010B are included (TDR/TDT mode). In addition, the S97011B enables more detailed measurements and evaluations, such as eye-diagram/mask modes, without adding PLTS software. Jitters and/or emphasis/equalization capabilities enables simulation of real-world signals and environment. S97011B covers up to 53 GHz bandwidth with 8.42 psec rise time. Full calibration is available and automatic deskew ensures easy removal of fixture and probe effects. To get the best accuracy, mechanical calibration kits or ECal with DC option (i.e. N443xD or N469xD with Option 0DC) are recommended.

Real time S-parameter and power measurement uncertainty (S97015B)

P93xxB Series

P50xxB Series

This application provides uncertainties for both S-parameter and power measurements on the P50xxB. The real-time display of the uncertainty associated with power and S-parameter traces increases the confidence in the reproducibility of measurements. This allows users to implement pass/fail tests easily because now the instrument quantifies the gray region that is in between a full pass or a full fail, apply more realistic limit lines which can increase the production yield and reduce the defect percentage on the finished products. This application easily establishes a metric to quantify the quality of the measurement process, so your company's quality control procedures are simplified. It includes the uncertainty information for most Keysight calibration kits and provides national metrology institute traceability through Keysight's calibration kits. This application also helps you to include uncertainty information for your product's specifications and data sheets.

Basic Pulsed-RF measurements lite (S970240B/S970241B)

P93xxB Series

P50xxB Series

This application enables internal pulse generators of P500xB or P502xB Series that can be used to control the internal pulse modulators, and it provides an integrated pulse application that uses the wideband-detection method.

The pulse application provides an easy way to set up point-in-pulse measurements with pulse width as narrow as 50 us, and pulse-profile measurements with 1 us minimum timing resolution. Using the built-in pulse modulators, the P50xxB Series VNAs are complete pulsed-RF measurement solutions, eliminating the need for external test sets and pulse generators. S97024xB also controls external pulse generators and modulators and can synchronize to external master pulses. Y1731A I/O Adapter Module is recommended to access pulse signals with SMB connectors if using external master pulses or external pulse modulators.

S970240B is available with P50xxB up to 20 GHz (20 GHz models or less), and S970241B is available for P50xxB greater than 20 GHz. Hardware options are not needed for pulsed-RF measurements with P50xxB.

S97024xB is a subset of S97025xB, so they should not be installed together.

Basic Pulsed-RF measurements (S970250B/S970251B)

P93xxB Series

P50xxB Series

This application enables internal pulse generators of P500xB or P502xB Series that can be used to control the internal pulse modulators, and it provides an integrated pulse application that uses the wideband-detection method.

The pulse application provides an easy way to set up point-in-pulse measurements with pulse width as narrow as 1 us, and pulse-profile measurements with 40 ns minimum timing resolution. Using the built-in pulse modulators, the P50xxB Series VNAs are complete pulsed-RF measurement solutions, eliminating the need for external test sets and pulse generators. S97025xB also controls external pulse generators and modulators and can synchronize to external master pulses. Y1731A I/O Adapter Module is recommended to access pulse signals with SMB connectors if using external master pulses or external pulse modulators.

S970250B is available with P50xxB up to 20 GHz (20 GHz models or less), and S970251B is available for P50xxB greater than 20 GHz. Hardware options are not needed for pulsed-RF measurements with P50xxB.

Noise figure measurements with vector correction (S97029B)

P93xxB Series

P50xxB Series

This software application enables high-accuracy noise figure and noise-power measurements of amplifiers, frequency converters, and mixers, utilizing Keysight's unique vector-source-correction technique that uses Keysight N469xD Series ECal module as a source-impedance tuner¹ to remove the effects of imperfect system-source match. This approach yields accuracy that surpasses that provided by the Y-factor method and other cold-source implementations, especially for in-fixture, on-wafer, and automated-test environments. S97029B controls N469xD Series ECal modules configured as impedance tuners for use with the P50xxB Series VNA.

A scalar-calibrated method is also available that offers less accuracy but is faster and does not require an impedance tuner. This method requires an external switch to isolate the P50xxB's source signal during noise figure measurements. A 50-ohm load must be connected to the DUT's input using the switch.

The instrument's standard receivers are used for noise figure measurements with the S97029B. An external preamplifier, filter(s) and switches are required for devices with < 30 dB of excess noise (gain plus noise figure in dB). Y1731A I/O Adapter Module is recommended for synchronized measurements using the P50xxB VNA and external switches. A typical block diagram of vector-calibrated noise figure measurements is shown.

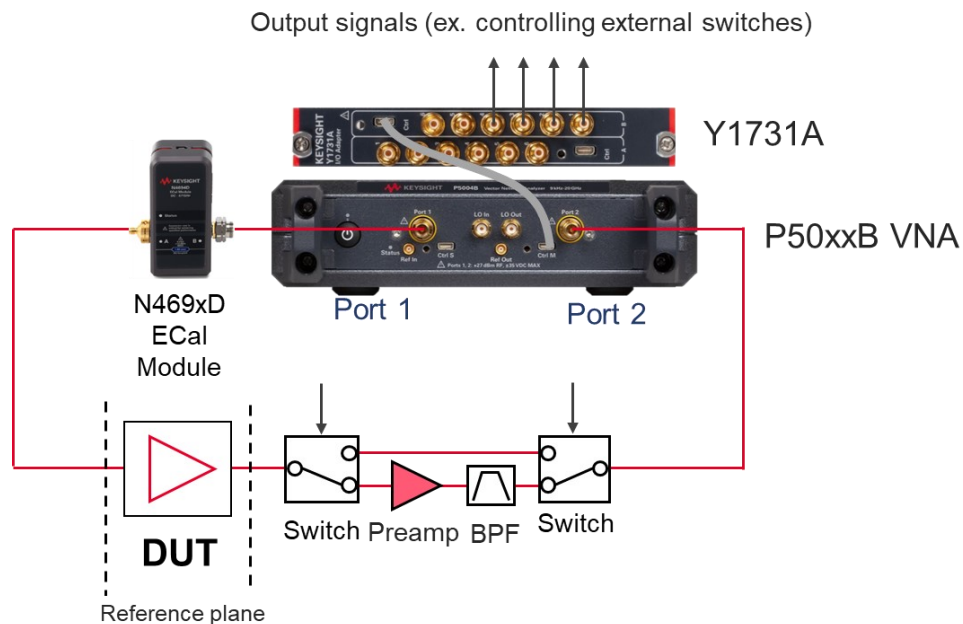

For calibration, a standard mechanical cal kit or ECal module is required for the S-parameter portion of the cal (an ECal used as a tuner cannot be shared for calibration). To calibrate a standard receiver for noise figure measurements, a power meter/sensor is required. A 346-series noise source (Keysight 346C or 346C-K01 recommended) can be used for noise calibration of the instrument's receiver, when a preamplifier is located before the receiver. All calibration accessories and external hardware must be ordered separately.

Noise figure measurements with the P50xxB are verified between 50 MHz and 45 GHz.

1. 8509x, N443xD or N755xA Series ECal modules are not supported.

Scalar mixer/converter measurements (S97082B)

P93xxB Series

P50xxB Series

The S97082B provides frequency offset mode (FOM) to set the frequency of the VNA's internal source(s) independently from where the receivers are tuned, and to configure external sources using External Device Configuration. This functionality is also included with S97029/083/084/086/089/S97090xB.

With a simple setup and calibration, this application delivers the highest accuracy for scalar conversion-loss/gain measurements by combining one-port and power-meter calibrations to remove mismatch errors. S97082B provides an intuitive and easy-to-use user interface for setting up mixer and converter measurements, with single or dual conversion stages. It can control external signal generators for use as LO signals. Supported external sources include the Keysight ESG, PSG, EXG, and MXG Series, as well as other SCPI-controlled signal generators.

S97082B is compatible with S97084B, which enables measurements of converters with internal LOs.

Vector and scalar mixer/converter measurements (S97083B)

P93xxB Series

P50xxB Series

This application includes the scalar mixer/converter plus phase (SMC+Phase) measurement class that provides fully calibrated conversion gain/loss, relative phase, and absolute group delay measurements of mixers and converters without the need for reference or calibration mixers. Eliminating the calibration mixer requires a U9391C/F/G comb generator¹ and an external DC power supply capable of sourcing +15 V and 300 mA for U9391C/F or 800 mA for U9391G. A macro-based series-reference-mixer version of VMC is also included for measuring the phase difference between multiple paths or devices, or for measuring phase shifts within the frequency-converting device. The macro also supports characterization of the calibration mixer that is supplied by the user.

SMC+Phase with the S97083B provides an intuitive and easy-to-use user interface for setting up mixer and converter measurements, with single or dual conversion stages. It can control the analyzer's built-in source(s) as well as external signal generators for use as LO signals. Supported external sources include the Keysight ESG, PSG, EXG, and MXG Series, as well as other SCPI-controlled signal generators. S97083B is a superset of S97082B, so they should not be installed together. S97083B is compatible with S97084B, which enables measurements of converters with internal LOs.

1. When a comb generator is used as a phase reference for calibration and the start frequency of the measurement is less than 630 MHz, a user-supplied calibration mixer is required.

Embedded LO capability (S97084B)

P93xxB Series

P50xxB Series

This application tunes the analyzer's receivers to the output frequency of the converter under test without the need for access to internal LOs or a common reference signal. S97084B is intended to work with S97082B and S97083B measurement applications.

Gain compression measurements (S97086B)

P93xxB Series

P50xxB Series

The gain compression application (GCA) provides input power, output power, gain, and phase at the compression point of an amplifier or frequency converters, over a specified frequency range. GCA's SMART Sweep is very fast and easy-to-use. GCA also includes a guided calibration that corrects for absolute power levels, frequency response, and mismatch errors.

Source phase control (S97088B)

P93xxB Series

P50xxB Series

This application allows users to set calibrated, arbitrary phase differences between two internal sources with the P502xB's option 402 (internal second source option), or multiple instrument measurements using two P50xxB VNAs with S97551B. The phase difference can be fixed or swept between two specified phase values. S97088B also controls the relative power level between the sources using the receiver-leveling feature. S97088B is targeted for active-load control, where the analyzer provides a precise, electronically settable impedance to the output port of a device, while gain and output power are measured. This capability can be combined with external load-pull software to create traditional load-pull power contours.

Differential and I/Q device measurements (S97089B)

P93xxB Series

P50xxB Series

This application combines source-phase control of multiple internal or external sources with frequency-offset mode, enabling simplified test of I/Q modulators/converters and differential mixers, and harmonic measurements of differential amplifiers. The phase difference between sources can be fixed (for example, at 90 or 180 degrees), or swept between two specified phase values. Providing accurate control of the relative phase between sources eliminates the need for hybrid couplers and baluns to create quadrature or differential signals. After achieving the desired phase alignment, the instrument's receivers can be tuned to all frequencies needed to characterize the DUT. On an I/Q modulator for example, measurements can be made of both the desired and suppressed conversion bands, along with LO leakage, harmonics and other spurious signals. Phase sweeps can be used to determine a DUT's phase imbalance versus frequency. Users can specify measurements with individual receivers or multiple receivers combined with a wide range of mathematical operators. Power measurements can employ match correction for increased accuracy. S97089B works on the P502xB with option 402 (internal second source option), or multiple instrument measurements using two P50xxB VNAs with S97551B.

Spectrum analysis (S97090xB)

P93xxB Series

P50xxB Series

The spectrum analyzer (SA) application adds high-performance microwave spectrum analysis to P50xxB VNAs. With fast stepped-FFT sweeps resulting from optimized data processing, the SA application provides quick spurious searches over broad frequency ranges. Simultaneous spectrum measurements can be done using test and reference receivers. This multi-channel SA can be used with the internal swept-signal generators for efficient measurements of spurious signals emanating from mixers and frequency converters. The SA application employs source-power and receiver-response calibration as well as fixture de-embedding, providing in-fixture and on-wafer spectrum measurements with the highest level of accuracy. Accurate and fast noise power ratio (NPR) measurement capability is also included in this software application. It provides the ability of setting up and controlling of external signal generator/arbitrary waveform generators and performing the calibration of the flatness of a wideband signal and distortion signals in notches and achieving very fast NPR measurements. Optional external attenuators should be connected to the VNA's test ports to avoid receiver compression when measuring large signals. The upper frequency range of the SA application is determined by the installed SA license or the stop frequency of the instrument, whichever is smaller. There are several frequency choices intended for standalone instruments: S970900B to 4.5 GHz, S970901B to 6.5 GHz, S970902B to 9 GHz, S970903B to 14 GHz, S970904B to 20 GHz, S970905B to 26.5 GHz, S970906B to 32 GHz, S970907B to 44 GHz, and S930908B to 53 GHz.

True-mode stimulus (S97460B)

P93xxB Series

P50xxB Series

The application provides mismatch-corrected true-mode (true differential mode and true common mode) stimulus and enables accurate balanced measurements under real operating conditions. It also provides balanced measurements with forward-only sweeps, reverse-only sweeps, and frequency or power sweeps with arbitrary phase and amplitude offsets.

S97460B works on the P502xB with option 402 (internal second source option), or multiple instrument measurements using two P50xxB VNAs with S97551B.

Multiple instrument measurements (S97551B)

P93xxB Series

P50xxB Series

Keysight Streamline Series VNA offers a capability to extend the number of ports for your measurements by using up to two VNA instruments. The instruments may be identified as one VNA by the firmware on an external host PC. At least one VNA instrument connected to your PC must have one S97551B license to maintain multiport capabilities with multiple instruments.

The frequency of the multiport array is determined by the lowest frequency instrument configured in the array. For example, a 6-port analyzer configuration using a P9372B (9 GHz) and a P9384B (20 GHz) would have a maximum frequency of 9 GHz when performing 6-port measurements. This behavior extends to other measurement application software (S97xxxB). A 4-port analyzer configuration using a P5002B (9 GHz) without SA software and P5004B (20 GHz) with S970904B (SA software up to 20 GHz) would have a maximum frequency of 9 GHz for S-parameter and SA measurements. In a multiport configuration, only one instrument must have a valid license of S97xxxB for these capabilities to function in multiport mode.

Each instrument is connected into the array with Keysight cables. A Y1701A Multiple USB instruments configuration kit must be ordered separately for connection of two 2-port VNA (P937xB or P500xB with Y1701A Option 002) or two 4- or 6-port VNA (P938xB or P502xB with Y1701A Option 002 or 003).

While all models of P937xB and P938xB, or P500xB and P502xB Series can be connected for multipoint configurations, P937xB (or P938xB) and P500xB (or P502xB) cannot be combined to configure a multipoint VNA due to hardware differences.



Figure 5. 4-port configuration using two P9377B VNAs (left), 6-port configuration using 2-port P9374B and 4-port P9384B (right).

Multipoint calibration assistant (S97552B)

P93xxB Series	P50xxB Series
---------------	---------------

This application software provides a tool to flexibly create and manage cal sets for multipoint measurements. For example, two cal sets with independent test ports can be combined as one cal set with a greater number of test ports. The software also offers a way to re-calibrate using a certain set of test ports to refresh the cal set.

At least one ECal module is required for the operation of S97552B.

Multipoint calibrated measurements with switch instruments (S97553B)

P93xxB Series	P50xxB Series
---------------	---------------

This application provides a macro which enables full multipoint error correction and measurement capabilities using external switch instruments such as the P9164A/B or P9165A/B USB Solid-state Switch Matrix. The software delivers an easy-to-use measurement wizard that simplifies measurement procedures and reduces the setup time of complicated multipoint measurements. Measured multipoint S-parameters are displayed in the VNA viewer.

Multipoint configurations using up to two Streamline Series VNAs and up to two switch matrices are supported.

Only the 4-port ECal modules (i.e. N4431/32/33D) are supported for multipoint calibration with the S97553B.

Material measurements

P93xxB Series

P50xxB Series

The Keysight N1500A materials measurement suite streamlines the process of measuring complex permittivity and permeability with a vector network analyzer. Various type of measurements, such as transmission line and free space, arch reflectivity, resonant cavity, and coaxial probe are available as options. The easy-to-use software guides the user through setup and measurement, instantly converting S-parameter network analyzer data into the data format of your choice and displaying the results within seconds. Results can be charted in a variety of formats: ϵ_r' , ϵ_r'' , tand, μ_r' , μ_r'' , tand μ , and Cole-Cole.

N1930xB Physical Layer Test System (PLTS) software

P93xxB Series

P50xxB Series

The PLTS software platform has become an industry standard for calibration, measurement, and analysis of linear passive interconnects such as cables, connectors, backplanes, and printed circuit boards. Utilizing either a vector network analyzer (VNA) or a time domain reflectometer (TDR), fast and accurate measurements can be obtained without in-depth knowledge of microwave measurement techniques. Refer to www.keysight.com/find/plts or the technical overview (literature number 5989-6841EN) for more details.

Device Measurement eXpert (DMX) (S94601B)

P93xxB Series

P50xxB Series

S94601B assists the users in setting up measurements automatically with customizable templates to use consistent measurement settings in different stages of design and test workflow. It supports various types of DUTs, and once the right DUT is selected, appropriate measurement parameters are listed, and the users can select the parameters of interest.

It provides intelligent algorithms that optimizes measurement setups based on instrument and DUT performance limitations and protects both the DUT and the instrument.

Limit assistant (S94602B)

P93xxB Series

P50xxB Series

S94602B allows the users to acquire the data from a VNA or data file in csv, s2p or prn format and easily generate limit masks for complex limit test conditions with an intuitive and convenient graphical interface for production test applications.

Automated measurement expert (AMX)

P93xxB Series

P50xxB Series

This software package is a smart software solution for automated S-parameter measurements with the Streamline Series VNA. The S94701A AMX test plan builder provides an interactive GUI which helps you edit your DUT test plans and generate test sequence files for the network analyzers. The S94702A and KS8400A software running on a host PC executes the test sequences according to the optimized test sequence files generated by the S94701A.

PathWave Vector Signal Analysis (89600 VSA) software

P93xxB Series

P50xxB Series

PathWave VSA software is a comprehensive set of tools for demodulation and vector signal analysis. Supporting P500xB or P502xB, the software provides the flexibility and sophisticated measurement tools essential to find and fix signal problems. The multi-channel measurement capability with the P50xxB VNA can configure, execute and display multiple measurements simultaneously to characterize numerous signals. Powerful display tools enable comparisons and correlation of results from different measurements.

S97090xB spectrum analysis software and PathWave Vector Signal Analysis (89600 VSA) software are required to enable vector signal analysis using the P50xxB. The maximum bandwidth of the P50xxB is 29 MHz. To synchronize to external vector signal generators, Y1730A-800/801/810 cables are recommended for connection with 10 MHz external reference ports (Ref In/Ref Out) of the P50xxB.

Refer to www.keysight.com/find/89600 to learn more about 89600 VSA software.

Vector Network Analyzer (VNA) simulator (S9405xB)

VNA simulator runs on your PC and simulates operations of Keysight's latest VNAs (PNA/ENA/PXI or Streamline Series VNA), eliminating the need for a VNA for your test program development. The simulator has standard and advanced versions. The standard version (S94050B) supports operations of standard S-parameter measurement class. The advanced version (S94051B) gives access to all advanced capabilities with S97xxxB software (ex. spectrum analysis) except S97007B, S97552B or S97553B software for Streamline Series VNAs.

S9405xB is available on subscription licenses only.

Direct Receiver Access (DRA) Configurations

Keysight Streamline Series VNAs support direct receiver access (DRA) configurations to flexibly set up test systems with optimized performance by integrating with external components¹ such as booster amplifiers, attenuators, or directional couplers. This function (included in the VNA firmware) combines three physical test ports of the Streamline Series VNA and defines them as a single logical port. You can perform measurements including calibration and post processing using the logical ports.

DRA configuration with high-power

One example using the DRA configuration is S-parameter measurements with high power. When you need an input level higher than the analyzer's source can provide, pre-amplifiers are necessary to boost the power level prior to the DUT. However, the reference signal is measured before the booster amplifier with a standard configuration of a 2-port VNA, and temperature drift or high reverse isolation of a booster amplifier will prevent accurate reflection measurements of the DUT's input.

A typical configuration for high-power measurements with the 4-port VNA is shown. A 4-port VNA (ex. P938xB or P502xB with Option 400/402), or a 4-port VNA² using two 2-port VNAs (ex. P937xB or P500xB with Option 200) are needed to setup the DRA configuration on port 1. Reflected and transmitted signals of the DUT are detected with all the logical receivers, and the VNA firmware provides measured high-power S-parameters.

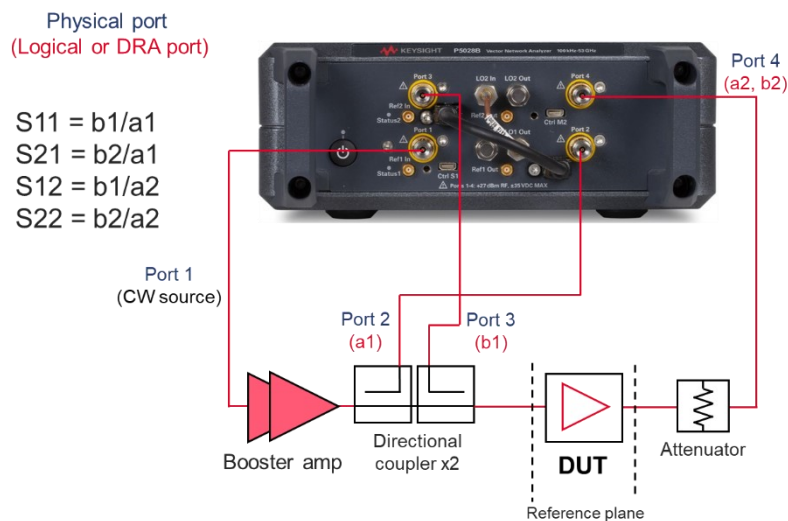

External components should be selected based on their high-power limits or frequency range specifications. Be sure that these components can handle the output power level of the booster amplifier.

1. External components are not included in Streamline Series VNA. Must be purchased separately.
2. The S97551B software is required to configure a multiport VNA with multiple Streamline Series VNAs.

Keysight Software Licensing Options Provide Flexibility and Support

Projects ramp up and down, teams grow and shrink, and projects move location. In such a dynamic environment, you need flexible licensing options that allow you to balance your project's requirements. Whether your software will be a staple for years to come or you have a short-term need for a leading-edge measurement application, Keysight's licensing puts you in charge.

Choose your term. Choose your type. Keep control of your budget.

- Select a node-locked license type.
- Select a subscription or perpetual license term, depending on how long you need to use the software.
- Each license is sold with a KeysightCare software support subscription which provides technical support with ensured response time, proactive software updates and enhancements.

Choose a license term and type that best suits your requirements from the table below.

License term

License term	Descriptions
Perpetual	Perpetual licenses can be used indefinitely.
Subscription	Licenses can be used through the term of the subscription (6, 12, 24, or 36 month)

License type

License type	Descriptions
Node locked ¹	License can be used on one specified instrument/computer.

1. Node-locked license is the only license type for S97xxxB.

KeysightCare Software Support Subscription provides peace of mind amid evolving technologies.

- Ensure your software is always current with the latest enhancements and measurement standards.
- Gain additional insight into your measurement problems with live access to our team of technical experts.
- Stay on schedule with fast turnaround times and priority escalations when you need support.

Subscription	Description
KeysightCare software support	Perpetual licenses are sold with a 12 (default), 24, 36, or 60-month software support subscription. Support subscriptions may be renewed for a fee after that.
	Software subscription licenses include a software support subscription through the term of the license.

Ordering Information

Step 1. Choose your software product.

Step 2. Choose your license term: perpetual or subscription.

Step 3. Choose your license type: node-locked.

Step 4. Depending on the license term, choose your subscription or support duration.

		License term			
Product	License type	Perpetual		Subscription	
S97xxxB ¹	Node-locked (fixed)	License		Support	License and support
		R-A5C-001-A	+	R-A6C-001-z	R-A4C-001-z
				z = Duration	z = Duration
				L 12 months (default)	F 6 months
				X 24 months	L 12 months
				Y 36 months	X 24 months
				Z 60 months	Y 36 months

1. For S97xxxB software, the fixed-perpetual with a 12-months, support subscription (R-A6C-001-L) is the only license type that can be ordered as part of the instrument and installed. The other license types for S97xxxB software must be ordered separately and installed from the web after the receipt of the instrument.

Measurement Accessories

A complete list of RF and microwave test accessories is available on our Web site: www.keysight.com/find/mta

Accessories are available in these connector types: 50 Ω Type-N, 3.5 mm, 7 mm, 2.4 mm, 2.92 mm, 1.85 mm, 1.0 mm, and waveguide. Test port cables and a calibration kit should be added for a complete measurement system. A verification kit is used to verify corrected system performance.

Cable and adapter sets

Keysight offers cables in the following types:

- Single cables in semi-rigid and flexible
- Cable sets in semi-rigid and flexible

There are also adapter sets available that protect the test port and convert the port to the desired connector interface. These kits contain:

- One male adapter
- One female adapter

To attain the best mechanical rigidity for device connection, use a single cable and the appropriate special adapter set. To attain the greatest flexibility for device connection, use a cable set.

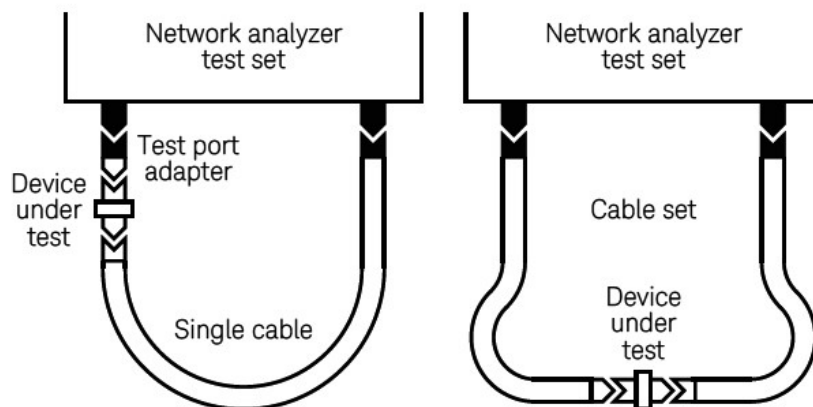

Calibration kits

Coaxial measurements

Mechanical calibration kits include standards, such as opens, shorts and loads, which are measured by the network analyzer for increased measurement accuracy.

Choose a calibration kit for each connector type to be used.

Economy, includes:

- Open standards (male and female)
- Short standards (male and female)
- Fixed-termination standards (male and female)

Standard, includes the devices in the economy kit and adds:

- Sliding load standards (male and female) or a series of offset shorts

Precision, includes the devices in the economy kit and adds:

- 50 Ω airline(s) for TRL calibration
- TRL adapters

Electronic calibration (ECal) kits replace mechanical calibration standards with one solid-state calibration module that is controlled by the network analyzer via USB, to present many different impedances to the test ports. A full two-port calibration can be performed quickly with a single connection. This technique reduces operator errors and connector wear and abrasion.

For more information about ECal modules, refer to the technical overview 5963-3743E (N4690, 85090, N4430 and N7550 Series).

Waveguide measurements

For waveguide measurements, Keysight offers mechanical calibration kits that include:

- Waveguide-to-coax adapters (X, P, K, R, Q, U, V)
- Precision waveguide section
- Flush short circuit
- Fixed terminations
- Straight section

For devices with 1.85 mm connectors

Mechanical calibration kit

85058B standard: DC to 67 GHz. Includes:

- 85058-60101 1.85 mm (m) short 5.4 mm
- 85058-60102 1.85 mm (m) short 6.3 mm
- 85058-60103 1.85 mm (m) short 7.12 mm
- 85058-60104 1.85 mm (m) short 7.6 mm
- 85058-60105 1.85 mm (f) short 5.4 mm
- 85058-60106 1.85 mm (f) short 6.3 mm
- 85058-60107 1.85 mm (f) short 7.12 mm
- 85058-60108 1.85 mm (f) short 7.6 mm
- 85058-60109 1.85 mm male open
- 85058-60110 1.85 mm female open
- 85058-60111 1.85 mm male load
- 85058-60112 1.85 mm female load
- 85058-60113 1.85 mm (m) to 1.85 mm (m) adapter
- 85058-60114 1.85 mm (f) to 1.85 mm (f) adapter
- 85058-60115 1.85 mm (m) to 1.85 mm (f) adapter

85058E economy: DC to 67 GHz. Includes:

- 85058-60101 1.85 mm (m) short 5.4 mm
- 85058-60105 1.85 mm (f) short 5.4 mm
- 85058-60109 1.85 mm male open
- 85058-60110 1.85 mm female open
- 85058-60123 1.85 mm male load
- 85058-60124 1.85 mm female load
- 85058-60113 1.85 mm (m) to 1.85 mm (m) adapter
- 85058-60114 1.85 mm (f) to 1.85 mm (f) adapter
- 85058-60115 1.85 mm (m) to 1.85 mm (f) adapter

Electronic calibration kits

N4694D Microwave ECal: DC or 10 MHz to 67 GHz, 2-ports. Includes:

Option F0F: Both connectors are 1.85 mm female on module

Option M0F: 1 female and 1 male 1.85 mm connector on module

Option M0M: Both connectors are 1.85 mm male on module

Option 0DC: DC to 67 GHz

Option 100: 10 MHz to 67 GHz

Option 00A adds:

85058-60113 1.85 mm (m) to 1.85 mm (m) adapter

85058-60114 1.85 mm (f) to 1.85 mm (f) adapter

For devices with 2.4 mm connectors

Mechanical calibration kit

85056A standard: DC to 50 GHz. Includes:

- 00901-60003 2.4 mm (m) fixed broadband load
- 00902-60004 2.4 mm (f) fixed broadband load
- 00915-60003 2.4 mm (m) sliding load
- 00915-60004 2.4 mm (f) sliding load
- 85056-60005 2.4 mm (m) to 2.4 mm (m) adapter
- 85056-60006 2.4 mm (f) to 2.4 mm (f) adapter
- 85056-60007 2.4 mm (m) to 2.4 mm (f) adapter
- 85056-60020 2.4 mm (m) short
- 85056-60021 2.4 mm (f) short
- 85056-60022 2.4 mm (m) open
- 85056-60023 2.4 mm (f) open

85056D economy: DC to 50 GHz. Includes:

- 00901-60003 2.4 mm (m) fixed broadband load
- 00902-60004 2.4 mm (f) fixed broadband load
- 85056-60005 2.4 mm (m) to 2.4 mm (m) adapter
- 85056-60006 2.4 mm (f) to 2.4 mm (f) adapter
- 85056-60007 2.4 mm (m) to 2.4 mm (f) adapter
- 85056-60020 2.4 mm (m) short
- 85056-60021 2.4 mm (f) short
- 85056-60022 2.4 mm (m) open
- 85056-60023 2.4 mm (f) open

Electronic calibration kits

N4693D ¹ Microwave ECal: DC or 10 MHz to 50 GHz, 2-ports. Includes:

Option F0F: Both connectors are 2.4 mm female on module

Option M0F: 1 female and 1 male 2.4 mm connector on module

Option M0M: Both connectors are 2.4 mm male on module

Option 0DC: DC to 50 GHz

Option 100: 10 MHz to 50 GHz

Option 00A adds:

85056-60005 2.4 mm (m) to 2.4 mm (m) adapter

85058-60006 2.4 mm (f) to 2.4 mm (f) adapter

For devices with K connectors (2.92 mm)

Electronic calibration kits

N4692D Microwave ECal: DC or 10 MHz to 40 GHz, 2-ports. Includes:

Option F0F: Both connectors are 2.92 mm female on module

Option M0F: 1 female and 1 male 2.92 mm connector on module

Option M0M: Both connectors are 2.92 mm male on module

Option 0DC: DC to 40 GHz

Option 100: 10 MHz to 40 GHz

Option 00A adds:

N4692-60021 2.92 mm (m) to 2.92 mm (m) adapter

N4692-60022 2.92 mm (f) to 2.92 mm (f) adapter

Adapters

11904A 2.4 mm (m) to 2.92 mm (m)

11904B 2.4 mm (f) to 2.92 mm (f)

11904C 2.4 mm (m) to 2.92 mm (f)

11904D 2.4 mm (f) to 2.92 mm (m)

11904S 2.4 mm to 2.92 mm:

Adapter set, contains 4 matched adapters

For devices with 3.5 mm or SMA connectors

Mechanical calibration kits

85033E economy: DC to 9 GHz. Includes:

- 85033-60016 3.5 mm (m) load
- 85033-60017 3.5 mm (f) load
- 85033-60018 3.5 mm (m) open
- 85033-60019 3.5 mm (f) open
- 85033-60020 3.5 mm (m) short
- 85033-60021 3.5 mm (f) short
- 8710-1761 torque wrench

Option 85033E-100 adds:

85027-60005 3.5 mm (f) to 3.5 mm (f) adapter

Option 85033E-200 adds:

85027-60007 3.5 mm (m) to 3.5 mm (m) adapter

Option 85033E-300 adds:

85027-60006 3.5 mm (m) to 3.5 mm (f) adapter

Option 85033E-400 adds:

- 1250-1744 3.5 mm (f) to 50 Ω Type-N (m) adapter
- 1250-1743 3.5 mm (m) to 50 Ω Type-N (m) adapter
- 1250-1745 3.5 mm (f) to 50 Ω Type-N (f) adapter
- 1250-1750 3.5 mm (m) to 50 Ω Type-N (f) adapter

Option 85033E-500 adds:

- 1250-1746 3.5 mm (m) to 7 mm adapter (two included)
- 1250-1747 3.5 mm (f) to 7 mm adapter (two included)

85052B standard: DC to 26.5 GHz. Includes:

- 00902-60003 3.5 mm (m) fixed load
- 00902-60004 3.5 mm (f) fixed load
- 00911-60019 3.5 mm (m) sliding load
- 00911-60020 3.5 mm (f) sliding load
- 85052-60006 3.5 mm (m) short
- 85052-60007 3.5 mm (f) short
- 85052-60008 3.5 mm (m) open
- 85052-60009 3.5 mm (f) open
- 85052-60012 3.5 mm (f) to 3.5 mm (f) adapter
- 85052-60013 3.5 mm (f) to 3.5 mm (m) adapter
- 85052-60014 3.5 mm (m) to 3.5 mm (m) adapter

85052C precision TRL: DC to 26.5 GHz. Includes:

- 00902-60003 3.5 mm (m) fixed load
- 00902-60004 3.5 mm (f) fixed load
- 85052-60006 3.5 mm (m) short
- 85052-60007 3.5 mm (f) short
- 85052-60008 3.5 mm (m) open
- 85052-60009 3.5 mm (f) open
- 85052-60032 3.5 mm (f) to 3.5 mm (f) adapter
- 85052-60033 3.5 mm (m) to 3.5 mm (m) adapter
- 85052-60034 3.5 mm (f) to 3.5 mm (m) adapter
- 85052-60035 3.5 mm short TRL line
- 85052-60036 3.5 mm long TRL line

85052D economy: DC to 26.5 GHz. Includes:

- 00902-60003 3.5 mm (m) fixed load
- 00902-60004 3.5 mm (f) fixed load
- 85052-60006 3.5 mm (m) short
- 85052-60007 3.5 mm (f) short
- 85052-60008 3.5 mm (m) open
- 85052-60009 3.5 mm (f) open
- 85052-60012 3.5 mm (f) to 3.5 mm (f) adapter
- 85052-60013 3.5 mm (f) to 3.5 mm (m) adapter
- 85052-60014 3.5 mm (m) to 3.5 mm (m) adapter

Electronic calibration (ECal) modules

85093C RF ECal: 300 kHz to 9 GHz, 2-ports. Standard module includes:

Option 00F: Both 3.5 mm connectors are female

Option 00M: Both 3.5 mm connectors are male

Option M0F: One female and one male connector, both 3.5 mm

Option 00A adds:

- 85052-60012 3.5 mm (f) to 3.5 mm (f) adapter
- 85052-60014 3.5 mm (m) to 3.5 mm (m) adapter

Option 150: Replaces standard storage container with a wooden box

85093C mixed-connector options

Port A Option			Port B Option		
Connector type	Female	Male	Connector type	Female	Male
3.5 mm	101	102	Type-N 50 Ω	203	204
			7-16	205	206

N4431B ECal: 300 kHz to 13.5 GHz, 4-ports

Connector type	Port A Option	Port B Option	Port C Option	Port D Option
Four 3.5 mm (f)	010			
Four Type-N 50 Ω (f)	020			
3.5 mm (f)	101	201	301	401
3.5 mm (m)	102	202	302	402
Type-N 50 Ω (f)	103	203	303	403
Type-N 50 Ω (m)	104	204	304	404
7-16 (f)	105	205	305	405
7-16 (m)	106	206	306	406

Option 150: Replaces standard storage container with a wooden box

N4431D Microwave ECal: DC to 13.5 GHz, 4 ports

Frequency option (mandatory)

Option 0DC: DC to 13.5 GHz

- Connector options

Option 010: 3.5 mm female connector on four ports on module

- Option 020: Type-N female connector on four ports on module

Connector Type	Port A Option	Port B Option	Port C Option	Port D Option
Four 3.5 mm (f)	010			
Four Type-N 50 Ω (f)	020			
3.5 mm (f)	101	201	301	401
3.5 mm (m)	102	202	302	402
Type-N 50 Ω (f)	103	203	303	403
Type-N 50 Ω (m)	104	204	304	404
7-16 (f)	105	205	305	405
7-16 (m)	106	206	306	406
4.3-10 (f)	107	207	307	407
4.3-10 (m)	108	208	308	408

N4433A ECal: 300 kHz to 20 GHz, 4-ports

Connector type	Port A Option	Port B Option	Port C Option	Port D Option
Four 3.5 mm (f)	010			
3.5 mm (f)	101	201	301	401
3.5 mm (m)	102	202	302	402

Option 150: Replaces standard storage container with a wooden box

N4433D ECal: DC/300 kHz to 26.5 GHz, 4-ports.

Frequency options

- Option 0DC: DC to 26.5 GHz
- Option 003: 300 kHz to 26.5 GHz

Connector Options:

- Option 010: 3.5 mm female connector on four ports on module

Connector Type	Port A Option	Port B Option	Port C Option	Port D Option
Four 3.5 mm (f)	010			
3.5 mm (f)	101	201	301	401
3.5 mm (m)	102	202	302	402

N4691D Microwave ECal, DC or 300 kHz to 26.5 GHz, 2-ports. Includes:

- Option F0F: Both 3.5 mm connectors are female
- Option M0F: One female and one male connector, both 3.5 mm
- Option M0M: Both 3.5 mm connectors are male
- Option 0DC: DC to 26.5 GHz
- Option 003: 300 kHz to 26.5 GHz
- Option 00A adds:
 - 85052-60012 3.5 mm (f) to 3.5 mm (f) adapter
 - 85052-60014 3.5 mm (m) to 3.5 mm (m) adapter

N755XA Series Economy ECal, 2-ports:

- N7550A DC to 4 GHz, 2-ports
- N7551A DC to 6.5 GHz, 2-ports
- N7552A DC to 9 GHz, 2-ports
- N7553A DC to 14 GHz, 2-ports
- N7554A DC to 18 GHz, 2-ports
- N7555A DC to 26.5 GHz, 2-ports

N755xA Series includes:

- Option 3FF: Both 3.5 mm connectors are female
- Option 3MF: One female and one male connector, both 3.5 mm
- Option 3MM: Both 3.5 mm connectors are male
- Option 150: Plastic storage box
- N7550X-151: 3.5 mm or 2.92 mm torque wrench

For devices with Type-N connectors

Mechanical calibration kits

85032F standard, DC to 9 GHz. Includes:

- 85032-60017 Type-N (m) fixed load
- 85032-60018 Type-N (f) fixed load
- 85032-60013 Type-N (m) open
- 85032-60014 Type-N (f) open
- 85032-60016 Type-N (m) short
- 85032-60015 Type-N (f) short

Option 85032F-100 adds:

- 85032-60021 Type-N (f) to Type-N (f) adapter

Option 85032F-200 adds:

- 85032-60019 Type-N (m) to Type-N (m) adapter

Option 85032F-300 adds:

- 85032-60020 Type-N (m) to Type-N (f) adapter

Option 85032F-500 adds:

- 85054-60001 Type-N (f) to 7 mm adapter (two included)
- 85054-60009 Type-N (m) to 7 mm adapter (two included)

85054B standard: DC to 18 GHz. Includes:

- 00909-60011 Type-N (m) fixed lowband load
- 00909-60012 Type-N (f) fixed lowband load
- 85054-60025 Type-N (m) short
- 85054-60026 Type-N (f) short
- 85054-60027 Type-N (m) open
- 85054-60028 Type-N (f) open
- 85054-60031 Type-N (f) to 7mm adapter
- 85054-60032 Type-N (m) to 7mm adapter
- 85054-60037 Type-N (f) to Type-N (f) adapter
- 85054-60038 Type-N (m) to Type-N (m) adapter
- 85054-80010 Type-N (f) sliding load
- 85054-80009 Type-N (m) sliding load
- 85054-60050 Type-N (f) connector gage
- 85054-60052 Type-N (f) gage master
- 85054-60051 Type-N (m) connector gage
- 85054-60053 Type-N (m) gage master

85054D economy: DC to 18 GHz. Includes:

- 85054-60025 Type-N (m) short
- 85054-60026 Type-N (f) short
- 85054-60027 Type-N (m) open
- 85054-60028 Type-N (f) open
- 85054-60031 Type-N (f) to 7mm adapter
- 85054-60032 Type-N (m) to 7mm adapter
- 85054-60037 Type-N (f) to Type-N (f) adapter
- 85054-60038 Type-N (m) to Type-N (m) adapter
- 85054-60046 Type-N (m) fixed load
- 85054-60047 Type-N (f) fixed load

Electronic calibration (ECal) modules

85092C RF ECal: 300 kHz to 9 GHz, 2 ports. Includes:

Option 00F: Both Type-N connectors are female

Option 00M: Both Type-N connectors are male

Option M0F: One female and one male connector, both Type-N

Option 00A adds:

85054-60037 Type-N (f) to Type-N (f) adapter

85054-60038 Type-N (m) to Type-N (m) adapter

N4431D ECal: DC to 13.5 GHz, 4-ports

Frequency option (mandatory)

- Option 0DC: DC to 13.5 GHz

Connector options

- Option 010: 3.5 mm female connector on four ports on module
- Option 020: Type-N female connector on four ports on module

Connector Type	Port A Option	Port B Option	Port C Option	Port D Option
Four 3.5 mm (f)	010			
Four Type-N 50 Ω (f)	020			
3.5 mm (f)	101	201	301	401
3.5 mm (m)	102	202	302	402
Type-N 50 Ω (f)	103	203	303	403
Type-N 50 Ω (m)	104	204	304	404
7-16 (f)	105	205	305	405
7-16 (m)	106	206	306	406
4.3-10 (f)	107	207	307	407
4.3-10 (m)	108	208	308	408

N4432A ECal: 300 kHz to 18 GHz, 4-ports

Connector type	Port A Option	Port B Option	Port C Option	Port D Option
Four Type-N 50 Ω (f)	020			
3.5 mm (f)	101	201	301	401
3.5 mm (m)	102	202	302	402
Type-N 50 Ω (f)	103	203	303	403
Type-N 50 Ω (m)	104	204	304	404

Option 150: Replaces standard storage container with a wooden box

N4432D ECal: DC or 300 kHz to 18 GHz, 4-ports

Frequency options

- Option 0DC: DC to 18 GHz
- Option 003: 300 kHz to 18 GHz

Connector options

- Option 020: Type-N female connector on four ports on module

Connector Type	Port A Option	Port B Option	Port C Option	Port D Option
Four Type-N 50 Ω (f)	020			
3.5 mm (f)	101	201	301	401
3.5 mm (m)	102	202	302	402
Type-N 50 Ω (f)	103	203	303	403
Type-N 50 Ω (m)	104	204	304	404

N4690D Microwave ECal, DC or 300 kHz to 18 GHz, 2-ports. Includes:

Option F0F: Both Type-N connectors are female

Option M0F: One female and one male connector, both Type-N connectors

Option M0M: Both Type-N connectors are male

Option 0DC: DC to 18 GHz

Option 003: 300 kHz to 18 GHz

Option 00A adds:

85054-60037 Type-N (f) to Type-N (f) adapter

85054-60038 Type-N (m) to Type-N (m) adapter

N755XA Series Economy ECal, 2-ports:

- N7550A DC to 4 GHz, 2-ports
- N7551A DC to 6.5 GHz, 2-ports
- N7552A DC to 9 GHz, 2-ports
- N7553A DC to 14 GHz, 2-ports
- N7554A DC to 18 GHz, 2-ports

N755xA Series includes:

- Option NFF: Both Type-N connectors are female
- Option NMF: One female and one male connector, both Type-N
- Option NMM: Both Type-N connectors are male
- Option 150: Plastic storage box
- N7550X-152: Type-N torque wrench

Adapter sets

11853A 50 Ω Type-N accessory kit. Includes:

- 1250-1472 Type-N (f) to Type-N (f) adapter (two included)
- 1250-1475 Type-N (m) to Type-N (m) adapter (two included)
- 11511A Type-N (f) short
- 11512A Type-N (m) short

11878A Type-N to 3.5 mm adapter kit. Includes:

- 1250-1744 3.5 mm (f) to 50 Ω Type-N (m) adapter
- 1250-1743 3.5 mm (m) to 50 Ω Type-N (m) adapter
- 1250-1745 3.5 mm (f) to 50 Ω Type-N (f) adapter
- 1250-1750 3.5 mm (m) to 50 Ω Type-N (f) adapter
- 11524A 7 mm to Type-N (f) adapter
- 11525A 7 mm to Type-N (m) adapter

For devices with 7 mm connectors

Mechanical calibration kits

85050B standard: DC to 18 GHz. Includes:

- 00909-60008 7 mm coax termination
- 85050-60006 7 mm fixed broadband load
- 85050-80007 7 mm short
- 85050-80010 7 mm open
- 85050-80011 7 mm sliding load

85050C precision TRL: DC to 18 GHz. Includes:

- 00909-60008 7 mm coax termination
- 85050-60003 7 mm to 7 mm airline
- 85050-60005 7 mm to 7 mm TRL adapter
- 85050-60006 7 mm fixed broadband load
- 85050-80008 7 mm short
- 85050-80009 7 mm short with collect
- 85050-80010 7 mm open

85050D economy: DC to 18 GHz. Includes:

- 85050-60006 7 mm fixed broadband load
- 85050-80007 7 mm short
- 85050-80010 7 mm open

For devices with waveguide

Mechanical calibration kits

X-Band

X11644A standard, WR-90: 8.2 to 12.4 GHz. Includes:

- 00896-60008 X-band standard section
- 00910-60003 X-band termination
- 11644-20018 X-band short
- 11644-20021 X-band shim
- X281C adapter (included in calibration kit): WR-90 to 7 mm

P Band

P11644A standard, WR-62: 12.4 to 18 GHz. Includes:

- 00896-60007 P-band standard section
- 00910-60002 P-band termination
- 11644-20017 P-band short
- 11644-20020 P-band shim
- P281C adapter (included in calibration kit): WR-62 to 7 mm

K Band

K11644A standard, WR-42: 18 to 26.5 GHz. Includes:

- 00896-60006 K-band standard section
- 00910-60001 K-band termination
- 11644-20016 K-band short
- 11644-20019 K-band shim
- K281C adapter (included in calibration kit): WR-42 to 3.5 mm (f) Option 012 WR-42 to 3.5 mm (m)

R Band

R11644A standard, WR-28: 26.5 to 40 GHz. Includes:

- 00914-20028 R-band termination
- 11644-20005 R-band short
- 11644-20003 R-band shim
- 11644-60001 R-band 10 cm straight waveguide
- 11644-60016 R-band 5 cm straight waveguide

Q Band

Q11644A standard, WR-22: 33 to 50 GHz. Includes:

- 11644-60005 Q-band termination
- 11644-20004 Q-band short
- 11644-20001 Q-band shim
- 11644-60002 Q-band 10 cm straight waveguide
- 11644-60017 Q-band 5 cm straight waveguide

U Band

U11644A standard, WR-19: 40 to 60 GHz. Includes:

- 11644-60006 U-band termination
- 11644-20004 U-band short
- 11644-20002 U-band shim
- 11644-60003 U-band 10 cm straight waveguide
- 11644-60018 U-band 5 cm straight waveguide

Verification kits

All Keysight verification kits include:

- Precision Z0 airline or match thru
- Mismatched airline or mismatch thru
- Fixed attenuators (except 85059V)
- Traceable measured data and uncertainties

85051B 45 MHz to 18 GHz 7 mm kit

Includes attenuators, airline and mismatch airline with data on a USB drive for use in confirming calibrated system performance, traceable to national standards. Test procedure is provided in the service manual.

85053B 300 kHz to 26.5 GHz 3.5 mm kit

Includes attenuators, airline and mismatch airline with data on a USB drive for use in confirming calibrated system performance, traceable to national standards. Test procedure is provided in the service manual.

85055A 300 kHz to 18 GHz Type-N kit

Includes attenuators, airline and mismatch airline with data on a USB drive for use in confirming calibrated system performance, traceable to national standards. Test procedure is provided in the service manual.

85057B 45 MHz to 50 GHz 2.4 mm kit

Includes attenuators, airline and mismatch airline with data on a USB drive for use in confirming calibrated system performance, traceable to national standards. Test procedure is provided in the service manual.

85058V 45 MHz to 67 GHz 1.85 mm kit

Includes attenuators, match thru and mismatch thru with data on a USB drive for use in confirming calibrated system performance, traceable to national standards. Test procedure is provided in the service manual.

Accessories

CalPod calibration refresh modules (8553xB/4xB)

P93xxB Series

P50xxB Series

CalPod calibration refresh modules allow in-situ calibration refreshes to be performed at the push of a button without removing the DUT or re-connecting calibration standards. CalPods are designed for any measurement situation where it is desirable to ensure that a valid calibration is present before recording measurement data. For example, they are useful for removing environmental effects such as cable movement and thermal-based changes of cables, connectors, and adapters, as well as connector and switch-matrix repeatability errors. The modules are especially useful in temperature, or thermal-vacuum chamber testing. CalPod modules are equipped with 2.92 mm connectors.

- 85530B 20 GHz ambient-temperature CalPod
- 85531B 20 GHz temperature-compensated CalPod
- 85532B 20 GHz thermal-vacuum compatible CalPod
- 85540B 40 GHz ambient-temperature CalPod
- 85541B 40 GHz temperature-compensated CalPod
- 85542B 40 GHz thermal-vacuum compatible CalPod
- 85523B CalPod controller (provides control for up to 4 CalPods)
- 85556A CalPod drive-cable splitter (allows control for up to 12 CalPods)
- 85554A CalPod drive cable extension (10-meter cascable extension cable)

PC Requirements for VNA Control

Requirement	
Operating systems	Windows 10 (64-bit only) Version 1909 or later
Available memory	4 GB minimum, 16 GB recommended
Available disk space	2 GB available disk space minimum
Display resolution	1024 X 768 minimum
Connection with VNA	Thunderbolt 3
Recommended CPU	Intel Core i7 10 th Generation or later

Literature Information

Keysight P93xxB and P50xxB Series Vector Network Analyzer – Data Sheet, [3121-1235.EN](#)

Keysight P93xxB Series Vector Network Analyzer - Technical Overview, [3121-1262.EN](#)

Keysight Vector Network Analyzer – Selection Guide, [5980-7603EN](#)

Electric Calibration (ECal) Modules – Technical Overview, [5963-7343E](#)

Web Resources

www.keysight.com/find/usb-vna

www.keysight.com/find/na

www.keysight.com/find/vnasoftware

www.keysight.com/find/ecal

Learn more at: www.keysight.com

For more information on Keysight Technologies' products, applications, or services, please contact your local Keysight office. The complete list is available at: www.keysight.com/find/contactus



Mouser Electronics

Authorized Distributor

Click to View Pricing, Inventory, Delivery & Lifecycle Information:

Keysight:

[P9370B/001](#) [P9371B/001](#) [P9372B/001](#) [P9373B/001](#) [P9374B/001](#) [P9375B/001](#) [Y1710A](#) [Y1740A-100](#) [Y1740A-200](#)
[Y1740A-300](#) [Y1740A-310](#) [Y1740A-400](#) [Y1701A-302](#) [Y1701A-303](#) [Y1701A-304](#) [Y1701A-400](#) [Y1701A-401](#)
[Y1701A-410](#) [Y1701A-001](#) [Y1701A-002](#) [Y1701A-003](#) [Y1701A-101](#) [Y1701A-102](#) [Y1701A-202](#) [S97082B/R-A5C-001-](#)
[A/R-A6C-001-L](#) [S97551B/R-A5C-001-A/R-A6C-001-L](#) [S97552B/R-A5C-001-A/R-A6C-001-L](#) [S97553B/R-A5C-001-A/R-](#)
[A6C-001-L](#) [Y1700A-001](#) [Y1700A-002](#) [P9377B/001](#) [P9382B/001](#) [P9384B/001](#) [S97007B/R-A5C-001-A/R-A6C-001-L](#)
[S97010B/R-A5C-001-A/R-A6C-001-L](#) [S97011B/R-A5C-001-A/R-A6C-001-L](#)