

XXS30B2AM12

Ultrasonic sensors XX, ultrasonic sensor, metal, cylindrical M30, straight, 2 m, 4...20 mA



Main

Range of product	Telemecanique Ultrasonic sensors XX
Sensor type	Ultrasonic sensor
Series name	General purpose
Sensor name	XXS
Sensor design	Cylindrical M30
Material	Metal
Type of output signal	Analogue
Wiring technique	5-wire
Analogue output function	4...20 mA
[Sd] sensing range	0.155...2 m

Complementary

Enclosure material	Nickel plated brass
Front material	Epoxy Rubber Resin
Function available	With synchronisation mode Software configurable
Blind zone	155 mm
Transmission frequency	120 kHz
Repeat accuracy	0.1 %
Deviation angle from 90° of object to be detected	-12...12 °
Current consumption	65 mA
Setting-up	Teach mode Configurator software
Maximum delay first up	250 ms
Maximum delay recovery	200 ms

Marking	CE
Threaded length	75.75 mm
Height	30 mm
Width	30 mm
Depth	102.15 mm
Product weight	0.19 kg

Environment

Standards	EN/IEC 60947-5-2 CSA C22.2 No 14 UL 508
Product certifications	cULus E2 EAC RCM Ecolab
Ambient air temperature for operation	-25...70 °C
Ambient air temperature for storage	-40...80 °C

Packing Units

Unit Type of Package 1	PCE
Number of Units in Package 1	1
Package 1 Weight	240 g
Package 1 Height	13 cm
Package 1 width	4.1 cm
Package 1 Length	9.5 cm

Offer Sustainability

Sustainable offer status	Green Premium product
REACH Regulation	REACH Declaration
EU RoHS Directive	Pro-active compliance (Product out of EU RoHS legal scope) EU RoHS Declaration
Mercury free	Yes
RoHS exemption information	Yes
Environmental Disclosure	Product Environmental Profile
California proposition 65	WARNING: This product can expose you to chemicals including: Diisononyl phthalate (DINP), which is known to the State of California to cause cancer, and Di-isodecyl phthalate (DIDP), which is known to the State of California to cause birth defects or other reproductive harm. For more information go to www.P65Warnings.ca.gov

Contractual warranty

Warranty	18 months
----------	-----------

Dimensions

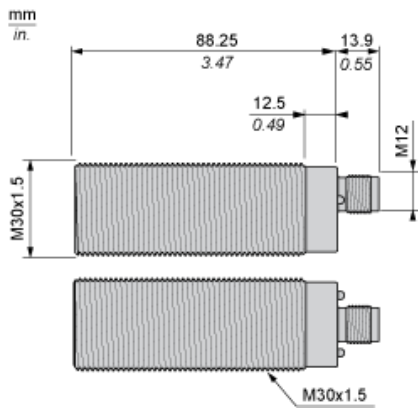

Connections

Connector Wiring

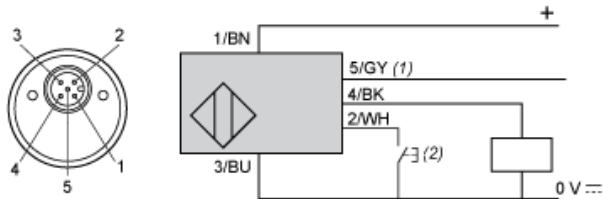

- (1) : Synchronization
(2) : External setting pushbutton or XXZPB100 remote teach pushbutton.

Pin number	Wire color	Description
1	BN: Brown	+12...24VDC
2	WH: White	Input teach
3	BU: Blue	0 VDC
4	BK: Black	Output
5	GY: Grey	Synchronization

Wiring Scheme. Analog Output



- (1) : Synchronization
4-20 mA For 12 VDC, load $\leq 250 \Omega$
For 24 VDC, load $\leq 850 \Omega$

Wiring for the Synchronization Function (Side by Side Application)

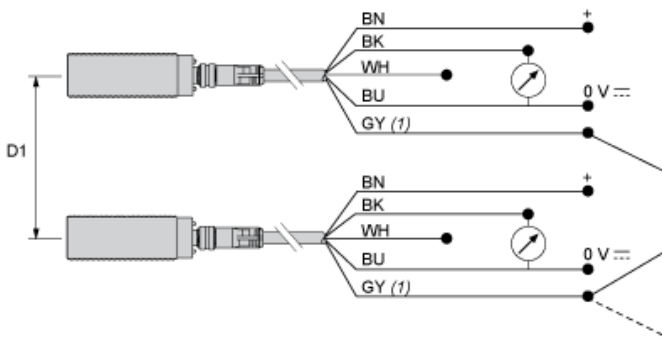

- (1) : Synchronization
D1: 1/8 Sn
BN: Brown
WH: White
BU: Blue
BK: Black
GY: Grey

NOTE: Up to 8 sensors can be synchronized to operate side by side by electrically connecting all pin no.5 (grey) wires together.

To synchronize more than 8 sensors, a PLC output can be used (the pins no.5 must be simultaneously driven by the rising edge of a pulse).

Performance Curves

Detection Curve with 100 x 100 mm / 3.94 x 3.94 inches Square Target

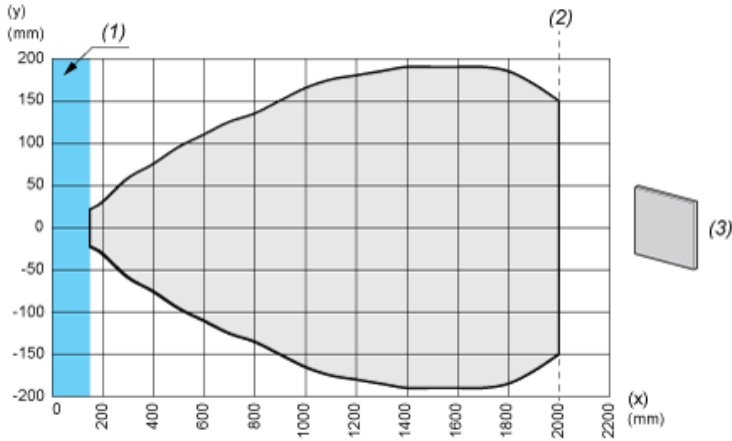

- (X) : Target distance
- (Y) : Detection limit
- (1) : Blind zone: 155 mm / 6.10 inches
- (2) : Sn max.
- (3) : 100 x 100 mm / 3.94 x 3.94 inches stainless steel plate

Detection Curve with Round Bar

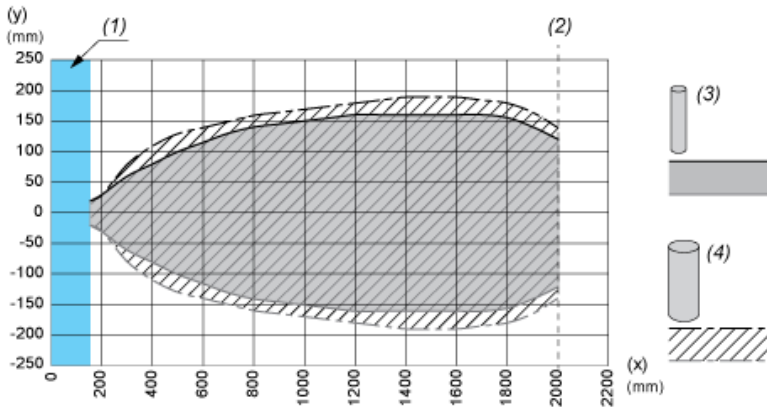

- (X) : Target distance
- (Y) : Detection limit
- (1) : Blind zone: 155 mm / 6.10 inches
- (2) : Sn max.
- (3) : Ø 10 mm / 0.394 inches stainless steel cylinder
- (4) : Ø 25 mm / 0.984 inches stainless steel cylinder