

PCB LAYOUT - COMPONENT VIEW

TECHNICAL CHARACTERISTICS

MATERIAL  
 INSULATOR MATERIAL: PBT  
 FLAMMABILITY RATING: UL94-V0  
 COLOR: BLACK  
 CONTACT MATERIAL: COPPER ALLOY  
 CONTACT TYPE: STAMPED  
 CONTACT PLATING: SELECTIVE GOLD  
 QUALITY CLASS: 500 MATING CYCLES

ENVIRONMENTAL  
 OPERATING TEMPERATURE: -25 °C UP TO 85 °C  
 COMPLIANCE: LEAD FREE AND ROHS

ELECTRICAL  
 CURRENT RATING: 1.5 A  
 WORKING VOLTAGE: 120 VAC  
 INSULATION RESISTANCE: >500 MΩ  
 DIELECTRIC WITHSTANDING VOLTAGE: 1 000 VAC/MIN  
 CONTACT RESISTANCE: 20 mΩ MAX

STANDARD  
 CERTIFIED: E324776

SOLDERING  
 JEDEC LEAD FREE WAVE SOLDERING PROCESS

PACKAGING  
 TRAY

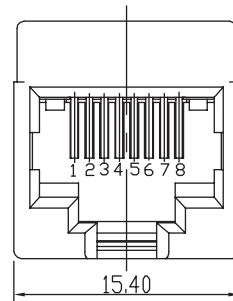
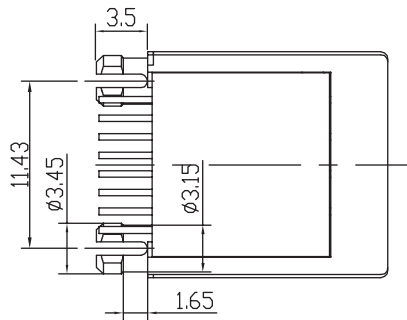
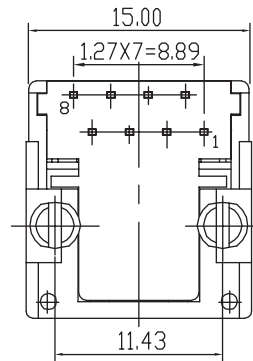
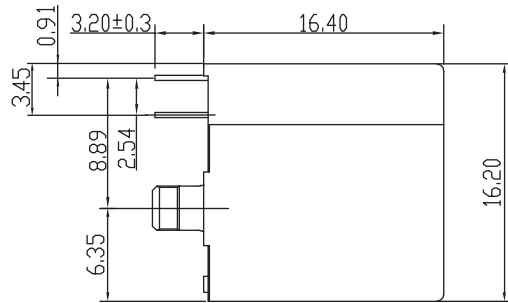

|                |           |             |    |
|----------------|-----------|-------------|----|
| RoHS Compliant |           |             |    |
|                |           |             |    |
|                |           |             |    |
|                |           |             |    |
|                |           |             |    |
| H              | 03-JAN-14 | TPK DWG ADD | QL |
| REV            | DATE      | FILE        | BY |

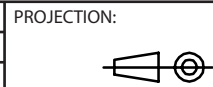

GENERAL TOLERANCE  
 .X = +/- 0.2  
 .XX = +/- 0.15



APPROVAL: RJ

UNIT: MM  
 SCALE:  
 SHEET: 1/1  
 DRAW:

DESCRIPTION: VERTICAL PLASTIC 8P8C MODULAR JACK  
 WERI PART NO: 615 008 138 021

SIZE  
**A4**

A

B

C

D

1

2

3

4

5



A

B

C

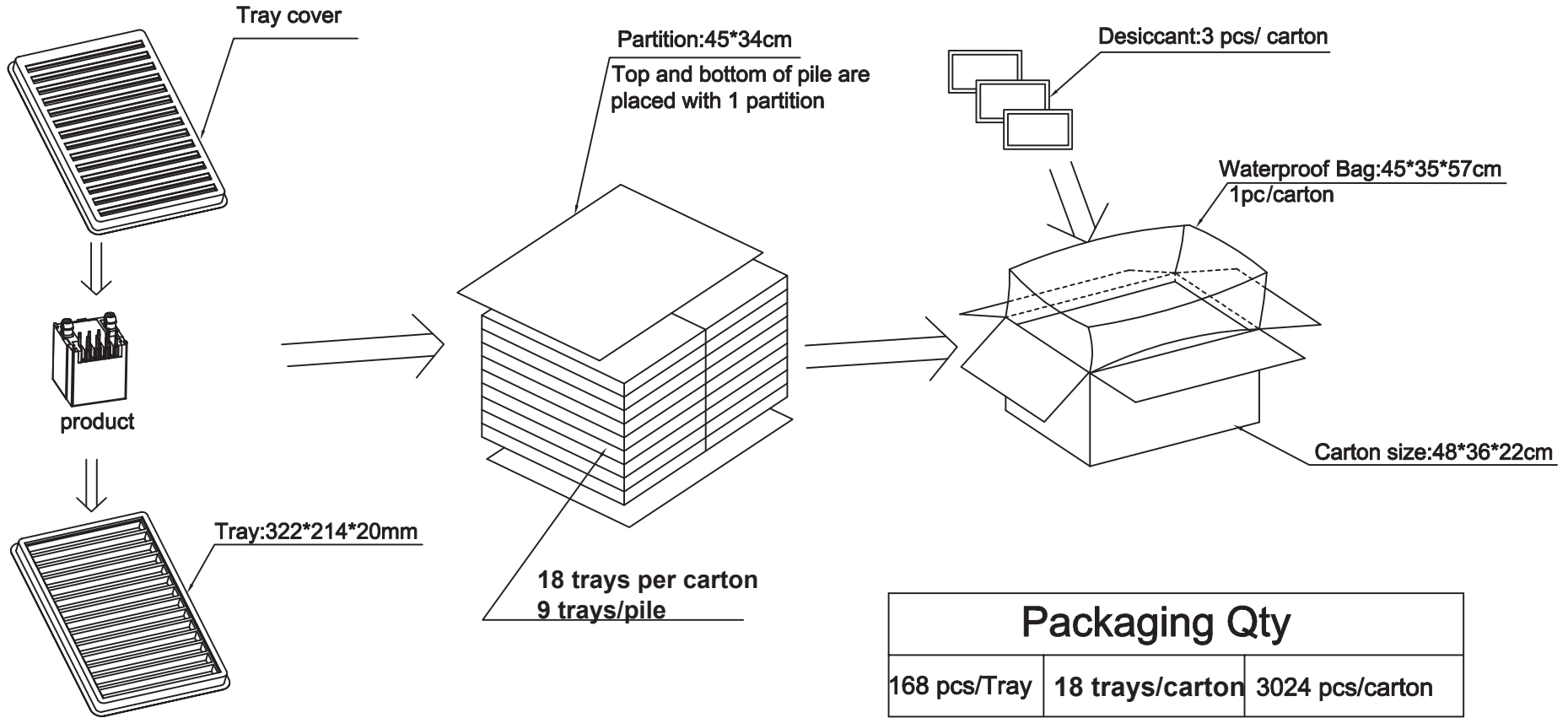
D

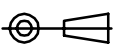

|                |      |      |              |  |   |   |   |                   |
|----------------|------|------|--------------|--|---|---|---|-------------------|
| RoHS Compliant |      |      |              | PROJECTION:<br> | GENERAL TOLERANCE<br>.X = +/- 0.2<br>.XX = +/- 0.15 |  | DESCRIPTION: VERTICAL PLASTIC 8P8C MODULAR JACK | SIZE<br><b>A4</b> |
| G              |      |      |              |  |   |   |   |                   |
| F              |      |      |              |  |   |   |   |                   |
| E              |      |      |              |  |   |   |   |                   |
| D              |      |      |              |  |   |   |   |                   |
| C              |      |      | APPROVAL: RJ | UNIT: MM   | WERI PART NO: 615 008 138 021                       |   |   |                   |
| B              |      |      |              | SCALE:   |   |   |   |                   |
| A              |      |      |              | SHEET: 1/1   |   |   |   |                   |
| REV            | DATE | FILE | BY           | DRAW:  |   |   |   |                   |

# Mouser Electronics

Authorized Distributor

Click to View Pricing, Inventory, Delivery & Lifecycle Information:

[Wurth Elektronik:](#)

[615008138021](#)