

KombiSIGN 71 / Terminal Element

**USB-Terminal element RM 5VDC BK**

Part No.:	640.840.00
Series:	KombiSIGN 71

**MECHANICAL DATA**

Length	70 mm
Width	70 mm
Height	41 mm
Diameter	70 mm
Materials	PA-GF
Housing colour	Black
Protection category	IP65
Connection	USB
Cable entry	Through hole
Cable entry maximum	d = 14 mm
Type of fixing	Tube mounting
Working temperature minimum	-20°C
Working temperature maximum	+50°C
Weight with packaging	185 g
Product weight	141 g

**ELECTRICAL DATA**

Operating voltage	5V (USB)
Operating voltage type	DC
Operating voltage tolerance	+/- 0%
Rated operational voltage	5 VDC
Rated operational current	500 mA
Protection class	Protection class 2
Pollution degree	3
Request to external PSU	SELV/PELV
Current carrying capacity	90mA
connectivity	USB

**OPTICAL DATA**

Service life optical	50,000 h maximum
----------------------	------------------

**APPROVAL DATA**

Conforms with CE	Yes
WEEE	Yes
Conforms with RED directive	No
Conforms with ATEX-directive	No
Conforms with CCC	No
Conforms with UL	No
Conforms with FCC	No



For additional installation and mounting information, refer to the appropriate user guide at [www.werma.com](http://www.werma.com). This printed copy is for information only and is subject to alteration.

KombiSIGN 71 / Terminal Element

**USB-Terminal element RM 5VDC BK**

Conforms with IC	No
EAC certificate available	Yes
Conforms with UKCA (Importer)	Yes (WERMA (UK) Ltd.)
Conforms with CMIM	No
Conforms with AS-I	No
ICAO Certification	No
Conforms with DNV	No
Conforms with RoHS CN	No
Conforms with VdS	No

**DRAWING**

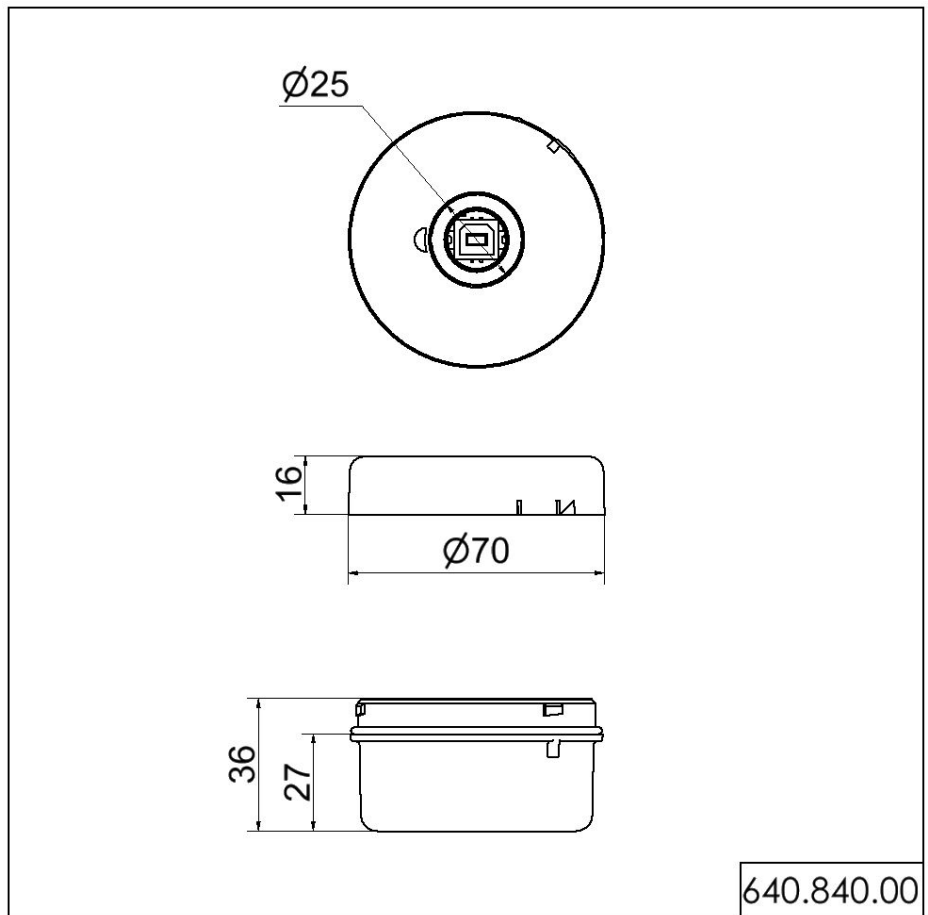

**!** For additional installation and mounting information, refer to the appropriate user guide at [www.werma.com](http://www.werma.com). This printed copy is for information only and is subject to alteration.