

Part Number: KPA-3010P3C

Features

- MECHANICALLY AND SPECTRALLY MATCHED TO THE KPA-3010 SERIES INFRARED EMITTING LED LAMP.
- WATER CLEAR LENS.
- PACKAGE : 2000PCS / REEL.
- MOISTURE SENSITIVITY LEVEL : LEVEL 3.
- RoHS COMPLIANT.

Description

Made with NPN silicon phototransistor chips.

Package Dimensions

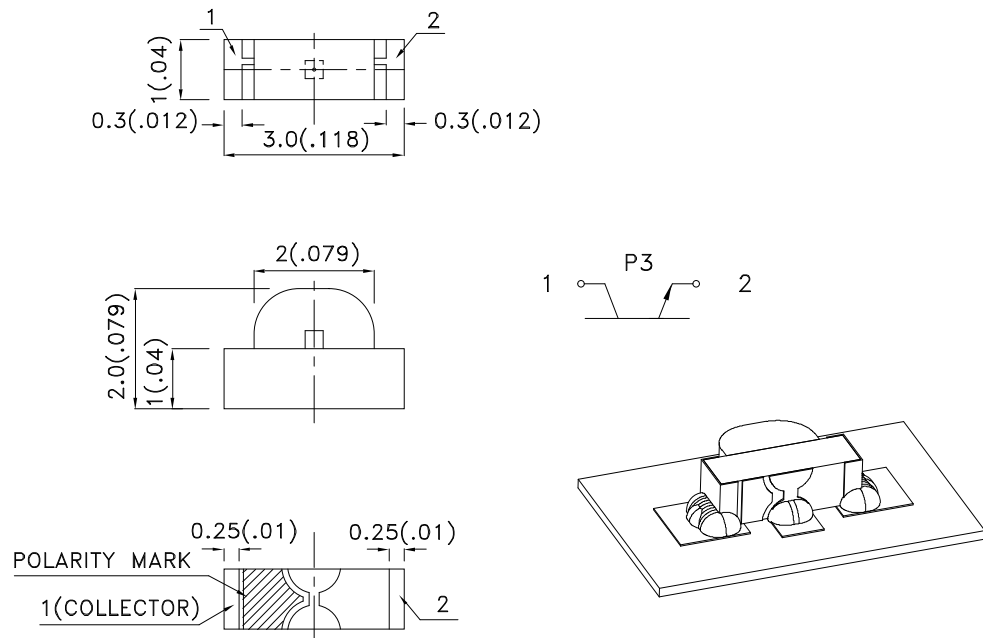

Notes:

1. All dimensions are in millimeters (inches).
2. Tolerance is $\pm 0.15(0.006")$ unless otherwise noted.
3. Specifications are subject to change without notice.
4. The device has a single mounting surface. The device must be mounted according to the specifications.

Electrical / Optical Characteristics at T_A=25°C

Symbol	Parameter	Min.	Typ.	Max.	Units	Test Conditions
V _{BR CEO}	Collector-to-Emitter Breakdown Voltage	30	-	-	V	I _C =100uA E _e =0mW/cm ²
V _{BR ECO}	Emitter-to-Collector Breakdown Voltage	5	-	-	V	I _E =100uA E _e =0mW/cm ²
V _{CE (SAT)}	Collector-to-Emitter Saturation Voltage	-	-	0.8	V	I _C =2mA E _e =20mW/cm ²
I _{CEO}	Collector Dark Current	-	-	100	nA	V _{CE} =10V E _e =0mW/cm ²
T _R	Rise Time (10% to 90%)	-	15	-	us	V _{CE} = 5V I _C =1mA R _L =1000Ω
T _F	Fall Time (90% to 10%)	-	15	-	us	
I _(ON)	On State Collector Current	0.1	0.3	-	mA	V _{CE} = 5V, E _e =1mW/cm ² , λ=940nm
2θ _{1/2}	Viewing Angle	-	120	-	deg	-

Absolute Maximum Ratings at T_A=25°C

Parameter	Max.Ratings
Collector-to-Emitter Breakdown Voltage	30V
Emitter-to-Collector Breakdown Voltage	5V
Power Dissipation at (or below) 25°C Free Air Temperature	100mW
Operating Temperature Range	-40°C ~ +85°C
Storage Temperature Range	-40°C ~ +85°C

KPA-3010P3C

Reflow Soldering Profile For Lead-free SMT Process.

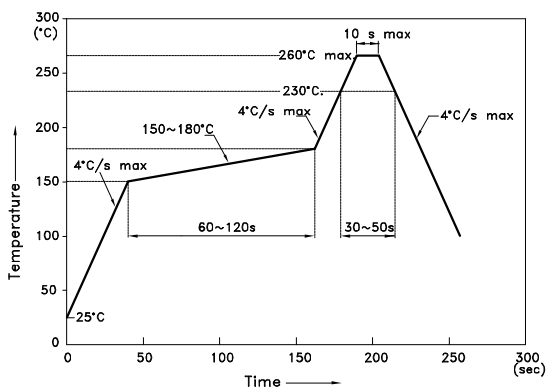

NOTES:

1. We recommend the reflow temperature 245°C(+/-5°C). The maximum soldering temperature should be limited to 260°C.
2. Don't cause stress to the epoxy resin while it is exposed to high temperature.
3. Number of reflow process shall be 2 times or less.

Recommended Soldering Pattern (Units : mm; Tolerance: ± 0.1)

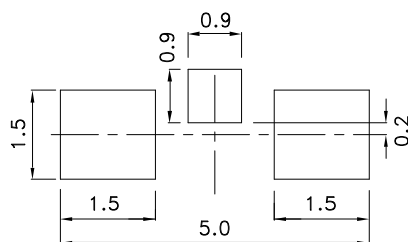

Tape Specifications (Units : mm)

