



PIC16F18446 Curiosity Nano

PIC16F18446 Curiosity Nano Hardware User Guide

Preface

The PIC16F18446 Curiosity Nano Evaluation Kit is a hardware platform to evaluate the PIC16F18446 microcontroller (MCU).

Supported by MPLAB® X IDE Integrated Development Environment (IDE), the kit provides easy access to the features of the PIC16F18446 to explore how to integrate the device into a custom design.

The Curiosity Nano series of evaluation kits include an on-board debugger. No external tools are necessary to program and debug the PIC16F18446.

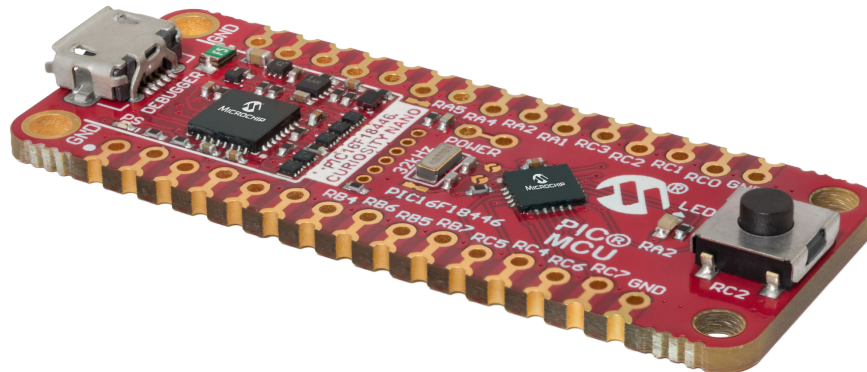

Table of Contents

| | |
|--|----|
| Preface..... | 1 |
| 1. Introduction..... | 4 |
| 1.1. Features..... | 4 |
| 1.2. Kit Overview..... | 4 |
| 2. Getting Started..... | 5 |
| 2.1. Curiosity Nano Quick Start MPLAB® Xpress..... | 5 |
| 2.2. Curiosity Nano Quick Start..... | 5 |
| 2.3. Design Documentation and Relevant Links..... | 5 |
| 3. Curiosity Nano..... | 7 |
| 3.1. On-board Debugger..... | 7 |
| 3.2. Curiosity Nano Standard Pinout..... | 10 |
| 3.3. Power Supply..... | 10 |
| 3.4. Target Current Measurement..... | 13 |
| 3.5. Disconnecting the On-Board Debugger..... | 14 |
| 4. Hardware User Guide..... | 16 |
| 4.1. Connectors..... | 16 |
| 4.2. Peripherals..... | 17 |
| 4.3. On-Board Debugger Implementation..... | 18 |
| 5. Hardware Revision History and Known Issues..... | 20 |
| 5.1. Identifying Product ID and Revision..... | 20 |
| 5.2. DAC pin limitations..... | 20 |
| 5.3. Revision 7..... | 20 |
| 5.4. Revision 5..... | 20 |
| 6. Document Revision History..... | 22 |
| 7. Appendix..... | 23 |
| 7.1. Schematic..... | 23 |
| 7.2. Assembly Drawing..... | 25 |
| 7.3. Curiosity Nano Base for Click boards™..... | 26 |
| 7.4. Connecting External Debuggers..... | 27 |
| The Microchip Website..... | 28 |
| Product Change Notification Service..... | 28 |
| Customer Support..... | 28 |
| Microchip Devices Code Protection Feature..... | 28 |
| Legal Notice..... | 28 |
| Trademarks..... | 29 |
| Quality Management System..... | 29 |

Worldwide Sales and Service.....30

1. Introduction

1.1 Features

- PIC16F18446-I/GZ Microcontroller
- One Yellow User LED
- One Mechanical User Switch
- One 32.768 kHz Crystal
- On-Board Debugger:
 - Board identification in MPLAB® X IDE
 - One green power and status LED
 - Programming and debugging
 - Virtual COM port (CDC)
 - One logic analyzer channel (DGI GPIO)
- USB Powered
- Adjustable Target Voltage:
 - MIC5353 LDO regulator controlled by the on-board debugger
 - 2.3 - 5.1 V output voltage (limited by USB input voltage)
 - 500 mA maximum output current (limited by ambient temperature and output voltage)

1.2 Kit Overview

The Microchip PIC16F18446 Curiosity Nano Evaluation Kit is a hardware platform to evaluate the PIC16F18446 microcontroller.

Figure 1-1. PIC16F18446 Curiosity Nano Evaluation Kit Overview

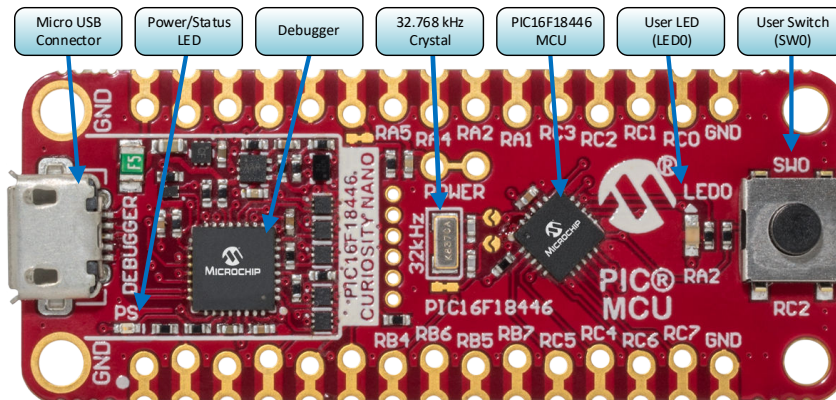

2. Getting Started

2.1 Curiosity Nano Quick Start MPLAB® Xpress

Steps to start exploring the Curiosity Nano platform with MPLAB Xpress:

1. Go to <https://mplabxpress.microchip.com>, and open MPLAB Xpress.
2. Create a new stand-alone project for PIC16F18446.
3. Use the MPLAB Xpress Code Configurator, or write your own code.
4. Compile and download your application HEX file.
5. Connect a USB cable (Standard-A to Micro-B or Micro-AB) between the PC and the debug USB port on the kit.
6. Copy the application HEX file into the *CURIOSITY* mass storage drive to program the application into the PIC16F18446.

To use advanced debug features of the Curiosity Nano kit, package the MPLAB Xpress project for MPLAB X IDE, and follow the quick start guide in the next section.

2.2 Curiosity Nano Quick Start

Steps to start exploring the Curiosity Nano platform:

1. Download MPLAB® X IDE.
2. Launch MPLAB® X IDE.
3. Connect a USB cable (Standard-A to Micro-B or Micro-AB) between the PC and the debug USB port on the kit.

When the Curiosity Nano kit is connected to your computer for the first time, the operating system will perform a driver software installation. The driver file supports both 32- and 64-bit versions of Microsoft® Windows® XP, Windows Vista®, Windows 7, Windows 8, and Windows 10. The drivers for the kit are included with MPLAB® X IDE.

Once the Curiosity Nano board is powered, the green status LED will be lit and MPLAB® X IDE will auto-detect which Curiosity Nano board is connected. MPLAB® X IDE will present relevant information like data sheets and kit documentation. The PIC16F18446 device is programmed and debugged by the on-board debugger and therefore no external programmer or debugger tool is required.

2.3 Design Documentation and Relevant Links

The following list contains links to the most relevant documents and software for the PIC16F18446 Curiosity Nano.

- [MPLAB® X IDE](#) - MPLAB® X IDE is a software program that runs on a PC (Windows®, Mac OS®, Linux®) to develop applications for Microchip microcontrollers and digital signal controllers. It is called an Integrated Development Environment (IDE) because it provides a single integrated “environment” to develop code for embedded microcontrollers.
- [MPLAB® Xpress Cloud-based IDE](#) - MPLAB® Xpress Cloud-Based IDE is an online development environment that contains the most popular features of our award-winning MPLAB X IDE. This simplified and distilled application is a faithful reproduction of our desktop-based program, which allows users to easily transition between the two environments.
- [MPLAB® Code Configurator](#) - MPLAB® Code Configurator (MCC) is a free software plug-in that provides a graphical interface to configure peripherals and functions specific to your application.
- [Microchip Sample Store](#) - Microchip sample store where you can order samples of devices.
- [Data Visualizer](#) - Data Visualizer is a program used for processing and visualizing data. The Data Visualizer can receive data from various sources such as the EDBG Data Gateway Interface found on Curiosity Nano and Xplained Pro boards and COM Ports.
- [PIC16F18446 Curiosity Nano website](#) - Kit information, latest user guide and design documentation.

PIC16F18446 Curiosity Nano

Getting Started

- [PIC16F18446 Curiosity Nano on microchipDIRECT](#) - Purchase this kit on microchipDIRECT.

3. Curiosity Nano

Curiosity Nano is an evaluation platform of small boards with access to most of the microcontrollers I/Os. The platform consists of a series of low pin count microcontroller (MCU) boards with on-board debuggers, which are integrated with MPLAB® X IDE. Each board is identified in the IDE, and relevant user guides, application notes, data sheets, and example code are easy to find. The on-board debugger features a Virtual COM port (CDC) for serial communication to a host PC, and a Data Gateway Interface (DGI) GPIO logic analyzer pin.

3.1 On-board Debugger

The PIC16F18446 Curiosity Nano contains an on-board debugger for programming and debugging. The on-board debugger is a composite USB device of several interfaces: A debugger, a mass storage device, a data gateway, and a Virtual COM port (CDC).

Together with MPLAB® X IDE, the on-board debugger can program and debug the PIC16F18446.

A Data Gateway Interface (DGI) is available for use with the logic analyzer channels for code instrumentation to visualize the program flow. DGI GPIOs can be graphed using the [Data Visualizer](#).

The Virtual COM port (CDC) is connected to a Universal Asynchronous Receiver/Transmitter (UART) on the PIC16F18446 and provides an easy way to communicate with the target application through terminal software.

The on-board debugger controls a Power and Status LED (marked PS) on the PIC16F18446 Curiosity Nano. The table below shows how the LED is controlled in different operation modes.

Table 3-1. On-Board Debugger LED Control

| Operation Mode | Status LED |
|------------------|---|
| Boot Loader mode | LED blink at 1 Hz during power-up. |
| Power-up | LED is ON. |
| Normal operation | LED is ON. |
| Programming | Activity indicator: The LED flashes slowly during programming/debugging. |
| Fault | The LED flashes fast if a power fault is detected. |
| Sleep/Off | LED is OFF. The on-board debugger is either in Sleep mode or powered down. This can occur if the kit is externally powered. |

3.1.1 Virtual COM Port (CDC)

The Virtual COM port (CDC) is a general purpose serial bridge between a host PC and a target device.

3.1.1.1 Overview

The on-board debugger implements a composite USB device that includes a standard Communications Device Class (CDC) interface, which appears on the host as a Virtual COM port. The CDC can be used to stream arbitrary data in both directions between the host and the target: All characters sent from the host will be sent through a UART on the CDC TX pin, and UART characters sent into the CDC RX pin will be sent back to the host through the Virtual COM port.

On Windows machines, the CDC will enumerate as *Curiosity Virtual COM Port* and appear in the Ports section of the Windows Device Manager. The COM port number can also be found there.

On Linux machines, the CDC will enumerate and appear as `/dev/ttyACM#`.

On MAC machines, the CDC will enumerate and appear as `/dev/tty.usbmodem#`. Depending on which terminal program is used, it will appear in the available list of modems as `usbmodem#`.



Info: On older Windows systems, a USB driver is required for CDC. This driver is included in MPLAB X IDE and Atmel Studio installations.

3.1.1.2 Limitations

Not all UART features are implemented in the on-board debugger CDC. The constraints are outlined here:

- **Baud rate:** Must be in the range 1200 bps to 500 kbps. Any baud rate outside this range will be set to the closest limit, without warning. Baud rate can be changed on-the-fly.
- **Character format:** Only 8-bit characters are supported.
- **Parity:** Can be odd, even, or none.
- **Hardware flow control:** Not supported.
- **Stop bits:** One or two bits are supported.

3.1.1.3 Signaling

During USB enumeration, the host OS will start both communication and data pipes of the CDC interface. At this point, it is possible to set and read back the baud rate and other UART parameters of the CDC, but data sending and receiving will not be enabled.

When a terminal connects on the host, it must assert the DTR signal. This is a virtual control signal implemented on the USB interface, but not in hardware in the on-board debugger. Asserting DTR from the host will indicate to the on-board debugger that a CDC session is active, will enable its level shifters (if available) and start the CDC data send and receive mechanisms.

Deasserting the DTR signal will not disable the level shifters but disable the receiver so no further data will be streamed to the host. Data packets that are already queued up for sending to the target will continue to be sent out, but no further data will be accepted.



Remember: Enable to set up your terminal emulator to assert the DTR signal. Without it, the on-board debugger will not send or receive any data through its UART.

3.1.1.4 Advanced Use

CDC Override Mode

In normal operation, the on-board debugger is a true UART bridge between the host and the device. However, under certain use cases, the on-board debugger can override the basic operating mode and use the CDC pins for other purposes.

Dropping a text file (with extension `.txt`) into the on-board debugger's mass storage drive can be used to send characters out of the CDC TX pin. The text file must start with the characters:

```
CMD:SEND_UART=
```

The maximum message length is 50 characters - all remaining data in the frame are ignored.

The default baud rate used in this mode is 9600 bps, but if the CDC is already active or has been configured, the baud rate last used still applies.

USB-Level Framing Considerations

Sending data from the host to the CDC can be done byte-wise or in blocks, which will be chunked into 64-byte USB frames. Each such frame will be queued up for sending to the CDC TX pin. Transferring a small amount of data per frame can be inefficient, particularly at low baud rates, since the on-board debugger buffers frames and not bytes. A maximum of 4 x 64-byte frames can be active at any time. The on-board debugger will throttle the incoming frames accordingly. Sending full 64-byte frames containing data is the most efficient.

When receiving data from the target, the on-board debugger will queue up the incoming bytes into 64-byte frames, which are sent to the USB queue for transmission to the host when they are full. Incomplete frames are also pushed to the USB queue at approximately 100 ms intervals, triggered by USB start-of-frame tokens. Up to 8 x 64-byte frames can be active at any time.

If the host, or the software running on it, fails to receive data fast enough, an overrun will occur. When this happens, the last-filled buffer frame will be recycled instead of being sent to the USB queue, and a full frame of data will be lost. To prevent this occurrence, the user must ensure that the CDC data pipe is being read continuously, or the incoming data rate must be reduced.

3.1.2 Mass Storage Disk

A simple way to program the target device is through drag and drop with `.hex` files.

3.1.2.1 Mass Storage Device

The on-board debugger implements a highly optimized variant of the FAT12 file system that has a number of limitations, partly due to the nature of FAT12 itself and optimizations made to fulfill its purpose for its embedded application.

The CURIOSITY drive is USB Chapter 9-compliant as a mass storage device but does not, in any way, fulfill the expectations of a general purpose mass storage device. This behavior is intentional.

The on-board debugger enumerates as a Curiosity Nano USB device that can be found in the disk drives section of the Windows device manager. The CURIOSITY drive appears in the file manager and claims the next available drive letter in the system.

The CURIOSITY drive contains approximately one MB of free space. This does not reflect the size of the target device's Flash in any way. When programming a `.hex` file, the binary data are encoded in ASCII with metadata providing a large overhead, so one MB is a trivially chosen value for disk size.

It is not possible to format the CURIOSITY drive. When programming a file to the target, the filename may appear in the disk directory listing. This is merely the operating system's view of the directory, which in reality, has not been updated. It is not possible to read out the file contents. Removing and replugging the kit will return the file system to its original state, but the target will still contain the application that has been previously programmed.

To erase the target device, copy a text file starting with "CMD:ERASE" onto the disk.

By default, the CURIOSITY drive contains several read-only files for generating icons as well as reporting status and linking to further information:

- `AUTORUN.ICO` - icon file for the Microchip logo
- `AUTORUN.INF` - system file required for Windows Explorer to show the icon file
- `KIT-INFO.HTM` - redirect to the development board website
- `KIT-INFO.TXT` - a text file containing details about the kit firmware, name, serial number, and device
- `STATUS.TXT` - a text file containing the programming status of the board



Info: `STATUS.TXT` is dynamically updated by the on-board debugger, the contents may be cached by the OS and therefore not reflect the correct status.

3.1.2.2 Configuration Words

Configuration Words (PIC® MCU Targets)

Configuration Word settings included in the project being programmed after program Flash is programmed. The debugger will *not* mask out any bits in the Configuration Words when writing them, but since it uses Low-Voltage Programming mode, it is unable to clear the LVP Configuration bit. If the incorrect clock source is selected, for example, and the board does not boot, it is always possible to perform a bulk erase (always done before programming) and restore the device to its default settings.

3.2 Curiosity Nano Standard Pinout

The twelve edge connections closest to the USB connector on Curiosity Nano kits have a standardized pinout. The program/debug pins have different functions depending on the target programming interface as shown in the table and figure below.

Table 3-2. Curiosity Nano Standard Pinout

| Debugger Signal | ICSP™ Target | Description |
|-----------------|--------------|-------------------------------|
| ID | - | ID line for extensions |
| CDC TX | UART RX | USB CDC TX line |
| CDC RX | UART TX | USB CDC RX line |
| DBG0 | ICSPDAT | Debug data line |
| DBG1 | ICSPCLK | Debug clock line/DGI GPIO |
| DBG2 | GPIO0 | DGI GPIO |
| DBG3 | MCLR | Reset line |
| NC | - | No connect |
| VBUS | - | VBUS voltage for external use |
| VOFF | - | Voltage Off input |
| VTG | - | Target voltage |
| GND | - | Common ground |

Figure 3-1. Curiosity Nano Standard Pinout

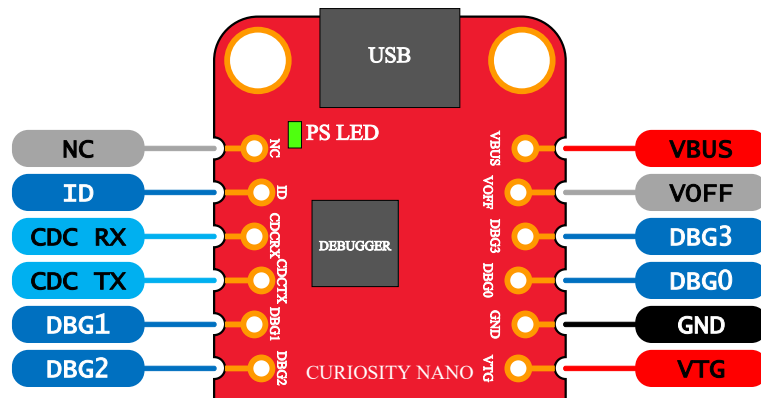

3.3 Power Supply

The kit is powered through the USB port and contains two LDO regulators, one to generate 3.3V for the on-board debugger, and an adjustable LDO regulator for the target microcontroller PIC16F18446 and its peripherals. The voltage from the USB connector can vary between 4.4V to 5.25V (according to the USB specification) and will limit the maximum voltage to the target. The figure below shows the entire power supply system on PIC16F18446 Curiosity Nano.

Figure 3-2. Power Supply Block Diagram

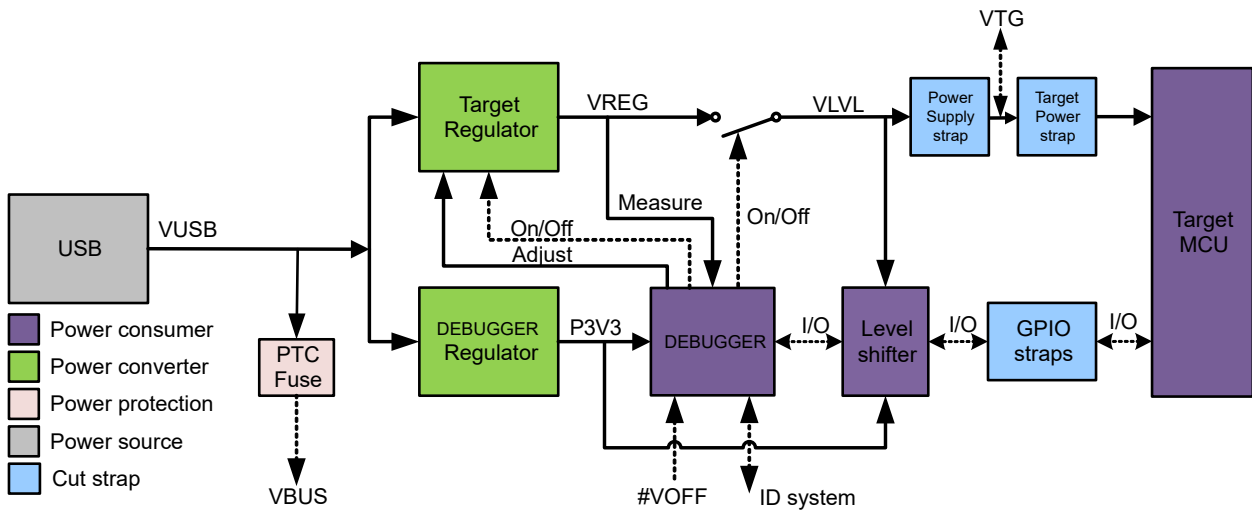

3.3.1 Target Regulator

The target voltage regulator is a MIC5353 variable output LDO. The on-board debugger can adjust the voltage output supplied to the kit target section by manipulating the MIC5353's feedback voltage. The hardware implementation is limited to an approximate voltage range from 1.7V to 5.1V. Additional output voltage limits are configured in the debugger firmware to ensure that the output voltage never exceeds the hardware limits of the PIC16F18446 microcontroller. The voltage limits configured in the on-board debugger on PIC16F18446 Curiosity Nano are 2.3 - 5.1 V.



Info: The target voltage is set to 3.3V in production. It can be changed through MPLAB X IDE project properties. Any change to the target voltage is persistent, even through a power toggle.

The MIC5353 supports a maximum current load of 500 mA. It is an LDO regulator in a small package, placed on a small printed circuit board (PCB), and the thermal shutdown condition can be reached at lower loads than 500 mA. The maximum current load depends on the input voltage, the selected output voltage, and the ambient temperature. The figure below shows the safe operating area for the regulator, with an input voltage of 5.1V and an ambient temperature of 23°C.

Figure 3-3. Target Regulator Safe Operation Area

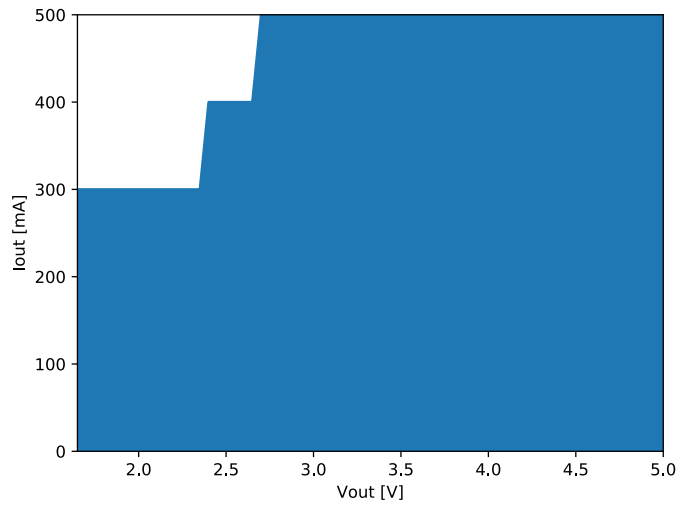

3.3.2 External Supply

PIC16F18446 Curiosity Nano can be powered by an external voltage instead of the on-board target regulator. When the Voltage Off (*VOFF*) pin is shorted to ground (*GND*) the on-board debugger firmware disables the target regulator, and it is safe to apply an external voltage to the VTG pin.



Applying an external voltage to the VTG pin without shorting *VOFF* to *GND* may cause permanent damage to the kit.



Absolute maximum external voltage is 5.5V for the on-board level shifters, and the standard operating condition of the PIC16F18446 is 2.3 - 5.5 V. Applying a higher voltage may cause permanent damage to the kit.

Programming, debugging, and data streaming are still possible with an external power supply: The debugger and signal level shifters will be powered from the USB cable. Both regulators, the debugger, and the level shifters are powered down when the USB cable is removed.

3.3.3 VBUS Output Pin

PIC16F18446 Curiosity Nano has a VBUS output pin which can be used to power external components that need a 5V supply. The VBUS output pin has a PTC fuse to protect the USB against short circuits. A side effect of the PTC fuse is a voltage drop on the VBUS output with higher current loads. The chart below shows the voltage versus the current load of the VBUS output.

Figure 3-4. VBUS Output Voltage vs. Current

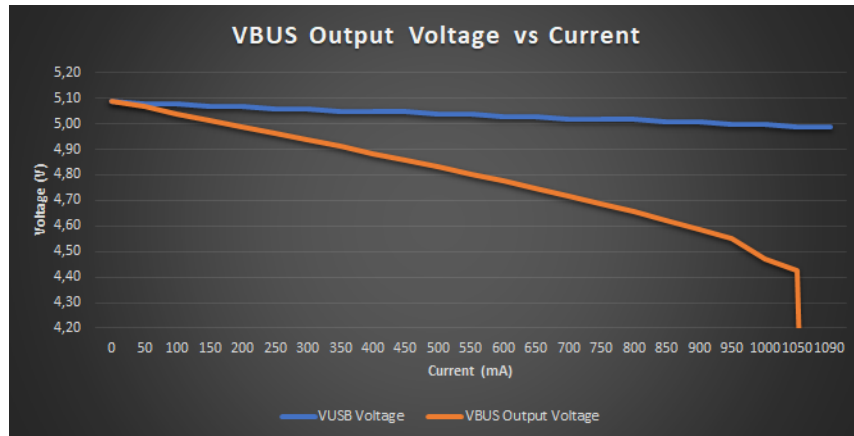

3.4 Target Current Measurement

Power to the PIC16F18446 is connected from the on-board power supply and VTG pin through a 100-mil pin header cut *Target Power strap* marked with “POWER” in silkscreen (J101). To measure the power consumption of the PIC16F18446 and other peripherals connected to the board, cut the *Target Power strap* and connect an ammeter over the strap.

Figure 3-5. Target Power Strap

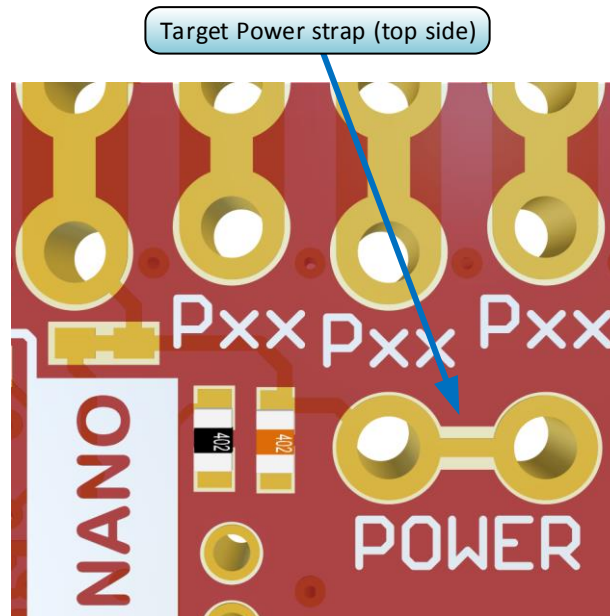

Tip: A 100-mil pin header can be soldered into the *Target Power strap* (J101) footprint for easy connection of an ammeter. Once the ammeter is not needed anymore, place a jumper-cap on the pin header.



Info: The on-board level shifters will draw a small amount of current even when they are not in use. A maximum of 10 μA can be drawn from the target power net, and an additional 2 μA can be drawn from each I/O pin connected to a level shifter for a total of 20 μA . Disconnect the on-board debugger and level shifters as described in Section 3.5 [Disconnecting the On-Board Debugger](#) and keep any I/O pin connected to a level shifter in tri-state to prevent leakage.

3.5 Disconnecting the On-Board Debugger

The block diagram below shows all connections between the debugger and the PIC16F18446 microcontroller. The rounded boxes represent connections to the board edge on PIC16F18446 Curiosity Nano. The signal names shown in [Figure 3-1](#) are printed in silkscreen on the bottom side of the board.

Figure 3-6. On-Board Debugger Connections to the PIC16F18446

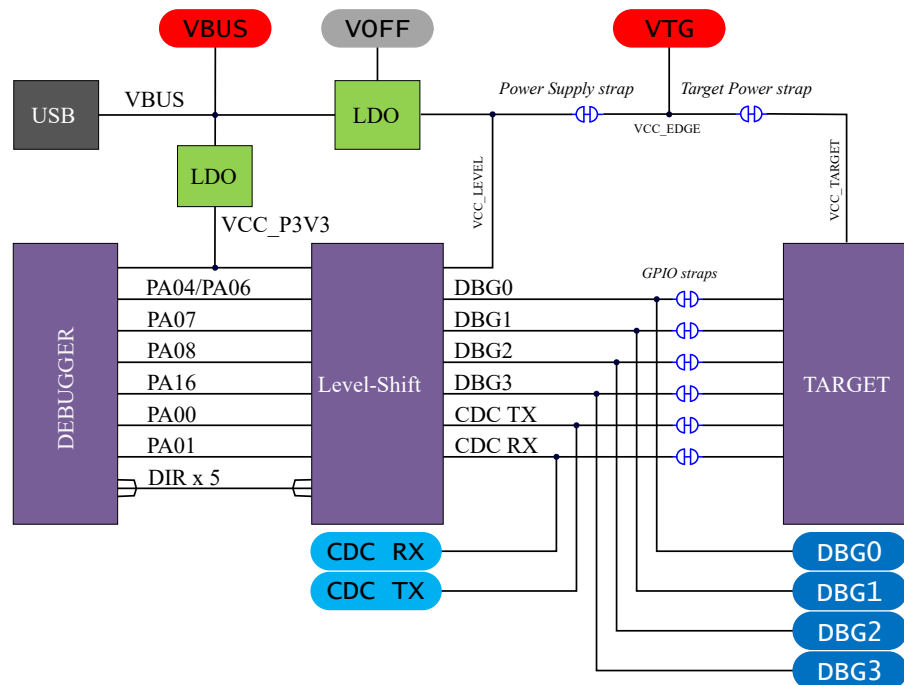

By cutting the *GPIO straps* with a sharp tool, as shown in [Figure 3-7](#), all I/Os connected between the debugger and the PIC16F18446 are completely disconnected. To completely disconnect the target regulator and level shifter power from the target, cut the *Power Supply strap* (J100) as shown in [Figure 3-7](#).



Info: Cutting the connections to the debugger will disable programming, debugging, data streaming, and the target power supply. The signals will also be disconnected from the board edge next to the on-board debugger section.



Tip: Solder in 0 Ω resistors across the footprints or short-circuit them with tin solder to reconnect any cut signals.

Figure 3-7. Kit Modifications

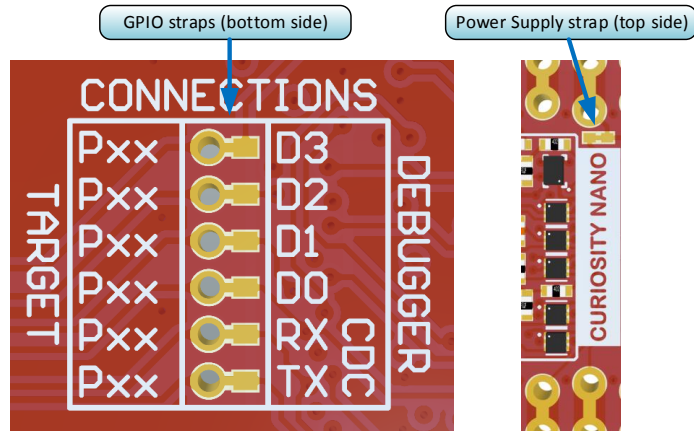

4. Hardware User Guide

4.1 Connectors

4.1.1 PIC16F18446 Curiosity Nano Pinout

All the PIC16F18446 I/O pins are accessible at the edge connectors on the board. The image below shows the kit pinout.

Figure 4-1. PIC16F18446 Curiosity Nano Pinout

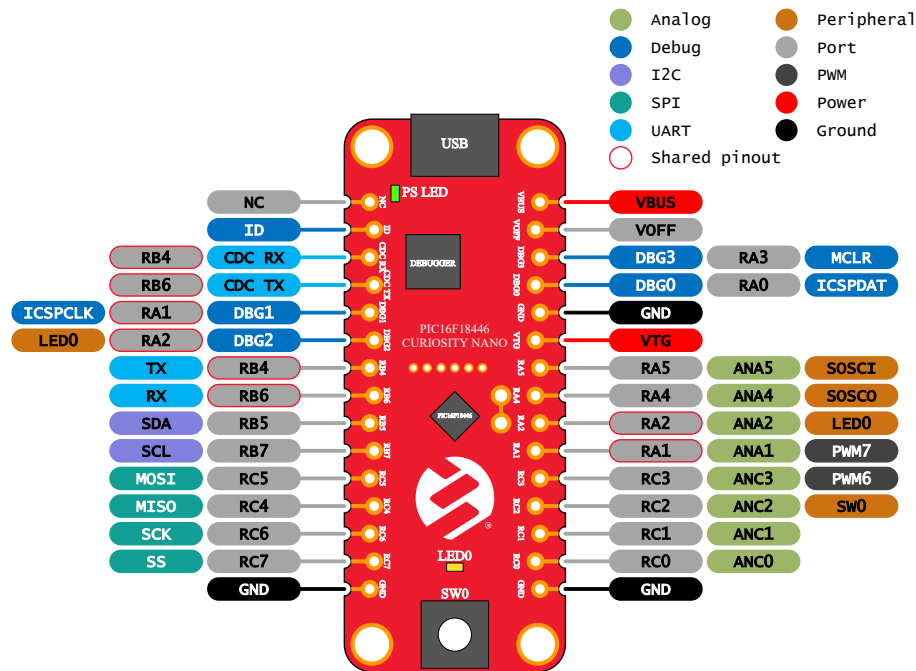

Info: Peripheral signals shown in the image above such as UART, I²C, SPI, ADC, PWM, and others are shown at specific pins to comply with the Curiosity Nano board standard. These signals can usually be routed to alternative pins using the Peripheral Pin Select (PPS) feature in the PIC16F18446.

4.1.2 Using Pin Headers

The edge connector footprint on PIC16F18446 Curiosity Nano has a staggered design where each of the holes is shifted 8 mil (~0.2 mm) off center. The hole shift allows the use of regular 100-mil pin headers on the kit without soldering. Once the pin headers are firmly in place, they can be used in normal applications like pin sockets and prototyping boards without any issues.



Tip: Start at one end of the pin header and gradually insert the header along the length of the board. Once all the pins are in place, use a flat surface to push them all the way in.



Tip: For applications where the pin headers will be used permanently, it is still recommended to solder them in place.



Important: Once the pin headers are in place, they are hard to remove by hand. Use a set of pliers and carefully remove the pin headers to avoid damage to the pin headers and PCB.

4.2 Peripherals

4.2.1 LED

There is one yellow user LED available on the PIC16F18446 Curiosity Nano kit that can be controlled by either GPIO or PWM. The LED can be activated by driving the connected I/O line to GND.

Table 4-1. LED Connection

| PIC16F18446 Pin | Function | Shared Functionality |
|-----------------|-------------|--------------------------------|
| RA2 | Yellow LED0 | Edge connector |

4.2.2 Mechanical Switch

The PIC16F18446 Curiosity Nano has one mechanical switch. This is a generic user-configurable switch. When the switch is pressed, it will drive the I/O line to ground (GND).



Tip: There is no externally connected pull-up resistor on the switch. To use the switch, make sure that an internal pull-up resistor is enabled on pin RC2.

Table 4-2. Mechanical Switch

| PIC16F18446 Pin | Description | Shared Functionality |
|-----------------|-------------------|--------------------------------|
| RC2 | User switch (SW0) | Edge connector |

4.2.3 Crystal

The PIC16F18446 Curiosity Nano board has a 32.768 kHz crystal mounted.

The crystal is not connected to the PIC16F18446 by default, as the GPIOs are routed out to the edge connector. To use the crystal, some hardware modifications are required. The two I/O lines routed to the edge connector should be disconnected to reduce the chance of contention to the crystal, and to remove excessive capacitance on the lines. This can be done by cutting the two straps on the bottom side of the board, marked RA4 and RA5 as shown in the figure below. Next, solder on a solder blob on each of the circular solder points next to the crystal on the top side of the board as shown in the figure below.

The 32.768 kHz crystal on PIC16F18446 Curiosity Nano is a Kyocera Corporation ST3215SB32768C0HPWBB 7 pF crystal.

The crystal has been formally tested and matched to the PIC16F18446 by Kyocera. The test report is available in the design documentation distributed with this document for PIC16F18446 Curiosity Nano.



Info: Kyocera Crystal Device Corporation crystals that are matched with specific products can be found on their website: http://prdct-search.kyocera.co.jp/crystal-ic/?p=en_search/

Table 4-3. Crystal Connections

| PIC16F18446 Pin | Function | Shared Functionality |
|-----------------|------------------------|----------------------|
| RA4 | SOSCO (Crystal output) | Edge connector |
| RA5 | SOSCI (Crystal input) | Edge connector |

Figure 4-2. Crystal Connection and Cut Straps

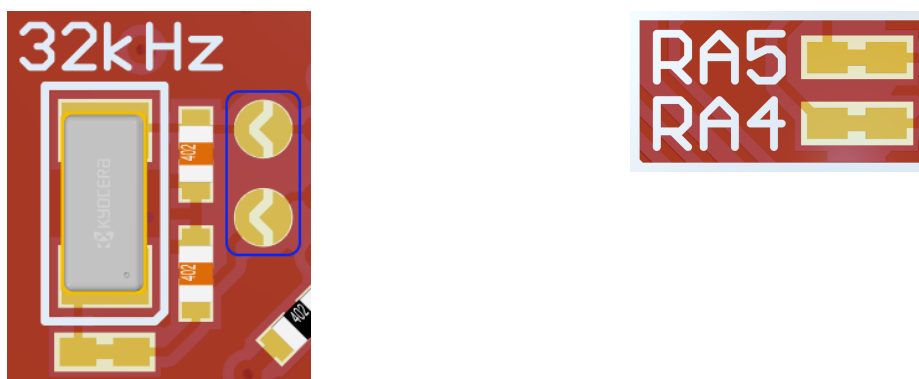

4.3 On-Board Debugger Implementation

PIC16F18446 Curiosity Nano features an on-board debugger that can be used to program and debug the PIC16F18446 using In-Circuit Serial Programming™ (ICSP™). The on-board debugger also includes a Virtual COM port (CDC) interface over UART and DGI GPIO. MPLAB® X IDE can be used as a front-end for the on-board debugger for programming and debugging. [Data Visualizer](#) can be used as a front-end for the CDC and DGI GPIO.

4.3.1 On-Board Debugger Connections

The table below shows the connections between the target and the debugger section. All connections between the target and the debugger are tri-stated as long as the debugger is not actively using the interface. Hence, there is little contamination of the signals the pins can be configured to anything the user wants.

For further information on how to use the capabilities of the on-board debugger, see Section 3. [Curiosity Nano](#).

Table 4-4. On-Board Debugger Connections

| PIC16F18446 Pin | Debugger Pin | Function | Shared Functionality |
|-----------------|--------------|-------------------------------|------------------------|
| RB6 | CDC TX | UART RX (PIC16F18446 RX line) | Edge connector |
| RB4 | CDC RX | UART TX (PIC16F18446 TX line) | Edge connector |
| RA0 | DBG0 | ICSP DAT | |
| RA1 | DBG1 | ICSP CLK | Edge connector |
| RA2 | DBG2 | GPIO | LED and Edge connector |
| RA3 | DBG3 | MCLR | |

PIC16F18446 Curiosity Nano

Hardware User Guide

.....continued

| PIC16F18446 Pin | Debugger Pin | Function | Shared Functionality |
|-----------------|--------------|----------------------------|----------------------|
| VCC_TARGET | VCC_LEVEL | 2.3 - 5.1 V Supply voltage | |
| GND | GND | Common ground | |

5. Hardware Revision History and Known Issues

This user guide provides the latest available revision of the kit. This section contains information about known issues, a revision history of older revisions, and how older revisions differ from the latest revision.

5.1 Identifying Product ID and Revision

The revision and product identifier of the PIC16F18446 Curiosity Nano can be found in two ways; either through MPLAB® X IDE or by looking at the sticker on the bottom side of the PCB.

By connecting a PIC16F18446 Curiosity Nano to a computer with MPLAB® X IDE running, an information window will pop up. The first six digits of the serial number, which is listed under kit details, contain the product identifier and revision.

The same information can be found on the sticker on the bottom side of the PCB. Most kits will print the identifier and revision in plain text as A09-nnnn\rr, where “nnnn” is the identifier and “rr” is the revision. The boards with limited space have a sticker with only a QR code, containing the product identifier, revision and the serial number.

The serial number string has the following format:

```
"nnnnrrssssssss"  
n = product identifier  
r = revision  
s = serial number
```

The product identifier for PIC16F18446 Curiosity Nano is A09-3120.

5.2 DAC pin limitations

The DAC output of the PIC16F18446 is on a shared pin with the ICSP clock signal. Due to the load introduced by the presence of pull-down resistor R204, required for debugging, the DAC output will not be as linear as the ideal output.

If a more linear response is desired, R204 can be removed. Be warned that this modification will render debugging unusable. Kit programming is not affected by this limitation, and can be done regardless of whether R204 is mounted.

5.3 Revision 7

Revision 7 improves the power supply circuit with PTC protection and the *Target Power strap* for current measurement.

The holes along the edge of the PCB are staggered for convenient use of pin headers without soldering.

5.4 Revision 5

Revision 5 is the initially released revision. [Figure 5-1](#) shows a top-down image of this revision alongside its assembly drawing.

This revision has a different power supply circuit than the one described in [Figure 3-2](#), in particular with regards to power protection used. Refer to [Figure 5-2](#) instead.

Revision 5 does not have the *Target Power strap* described in [3.4 Target Current Measurement](#), instead current can be measured across the *Power Suppl strap* as described in [3.5 Disconnecting the On-Board Debugger](#).

The holes along the edge connections are not staggered as described in [4.1.2 Using Pin Headers](#), and require soldering when mounting pin headers.

PIC16F18446 Curiosity Nano

Hardware Revision History and Known Issues

Figure 5-1. PIC16F18446 Curiosity Nano Revision 5 with assembly drawing

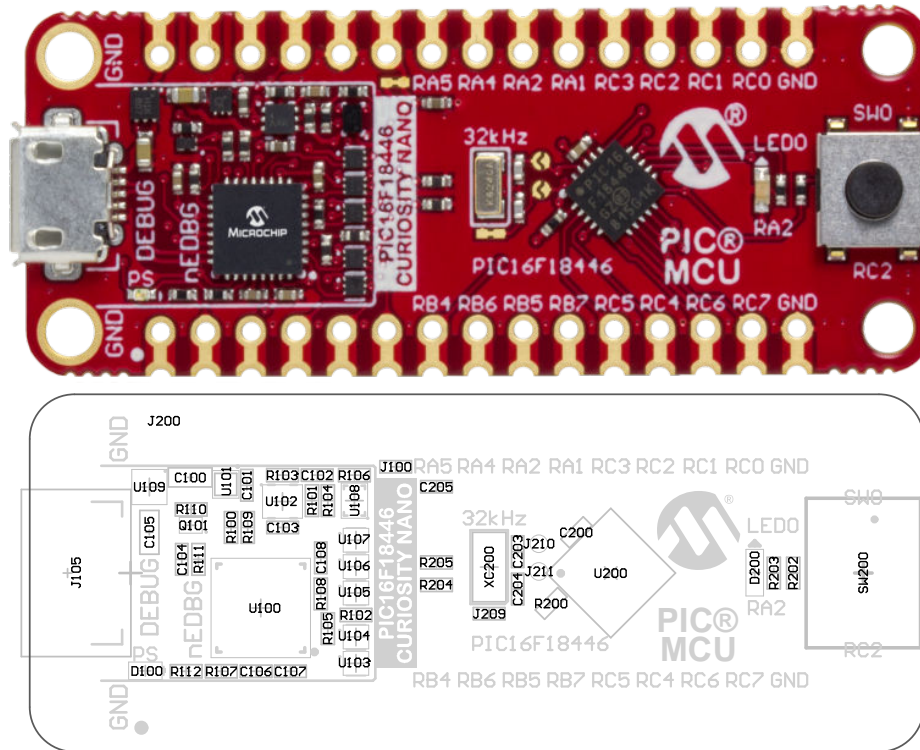
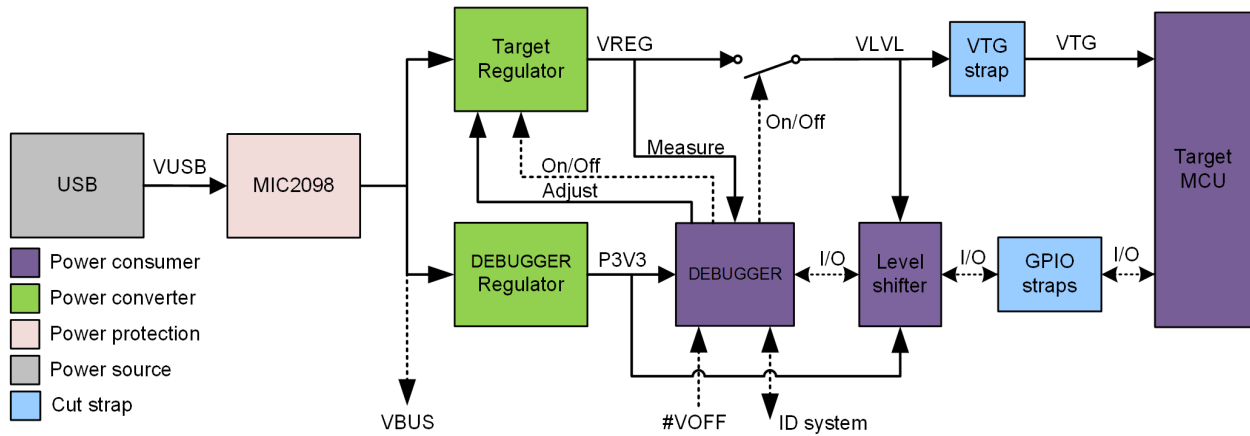

Figure 5-2. Power Supply Block Diagram for Revision 5 of the PIC16F18446 Curiosity Nano



6. Document Revision History

| Doc. rev. | Date | Comment |
|-----------|---------|----------------------------|
| B | 10/2019 | Added hardware revision 7. |
| A | 10/2018 | Initial document release. |

7.2 Assembly Drawing

Figure 7-2. PIC16F18446 Curiosity Nano Assembly Drawing Top

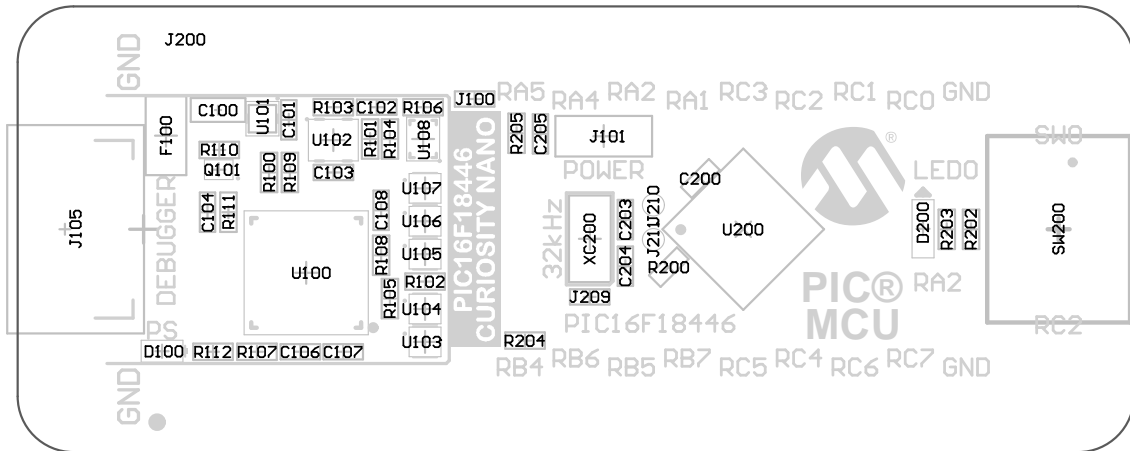
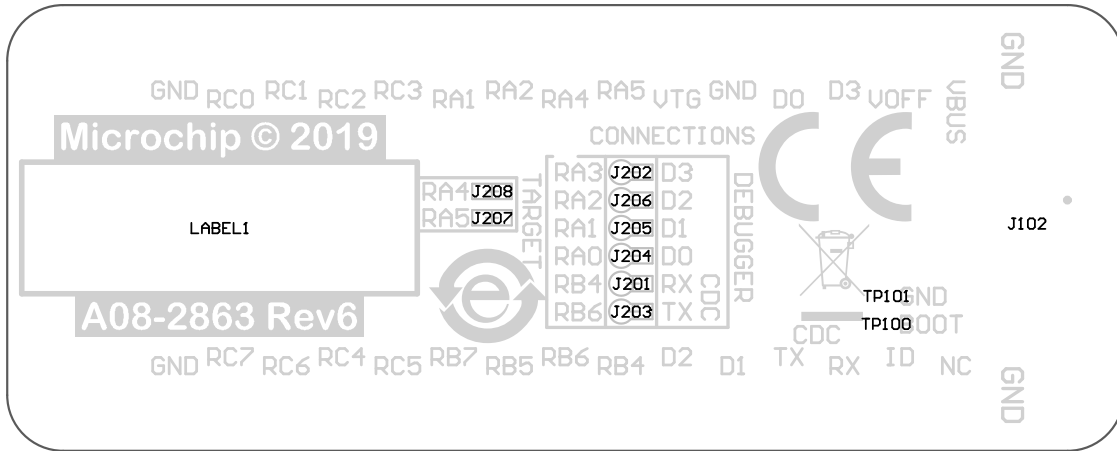
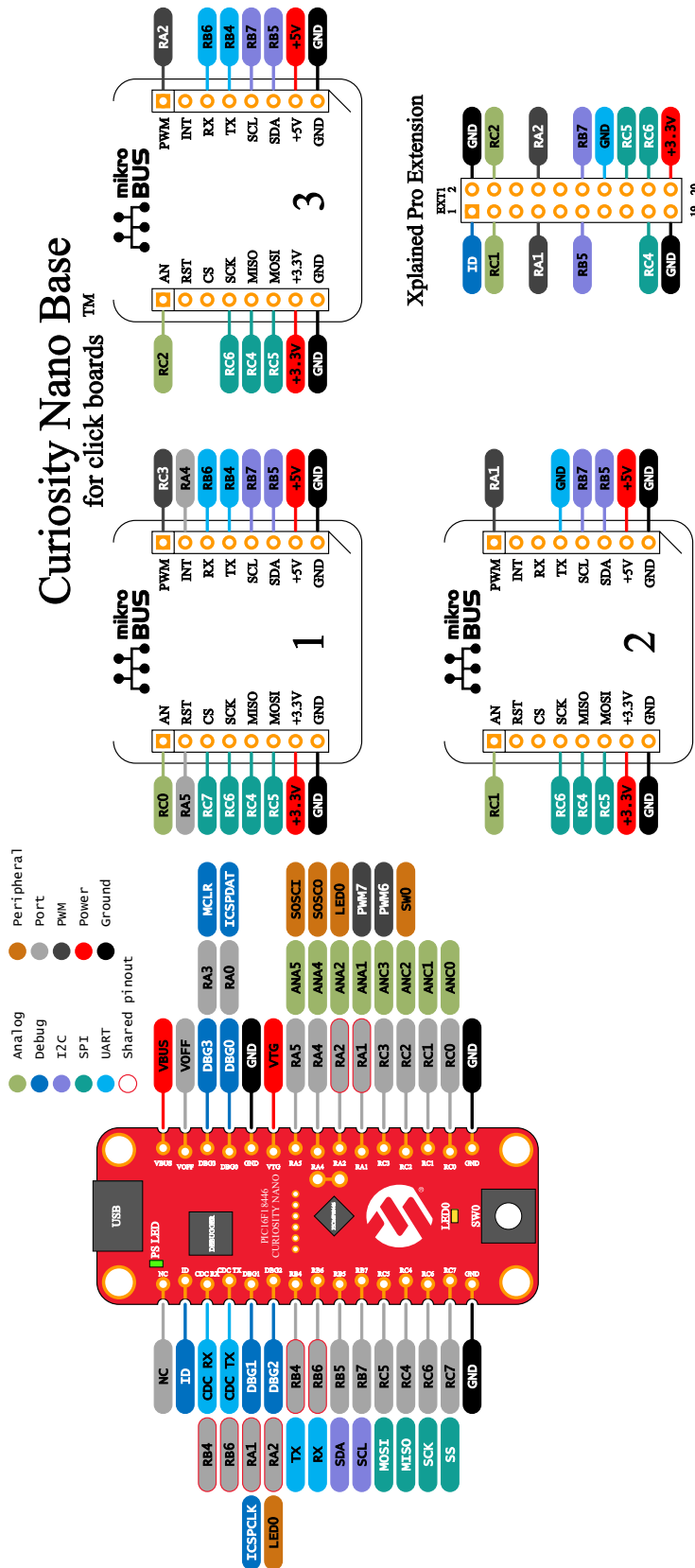

Figure 7-3. PIC16F18446 Curiosity Nano Assembly Drawing Bottom



7.3 Curiosity Nano Base for Click boards™

Figure 7-4. PIC16F18446 Curiosity Nano Pinout Mapping



7.4 Connecting External Debuggers

Even though there is an on-board debugger, external debuggers can be connected directly to the PIC16F18446 Curiosity Nano to program/debug the PIC16F18446. The on-board debugger keeps all the pins connected to the PIC16F18446 and board edge in tri-state when not actively used. Therefore, the on-board debugger will not interfere with any external debug tools.

Figure 7-5. Connecting the MPLAB PICKit™ 4 In-Circuit Debugger/Programmer to PIC16F18446 Curiosity Nano

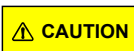
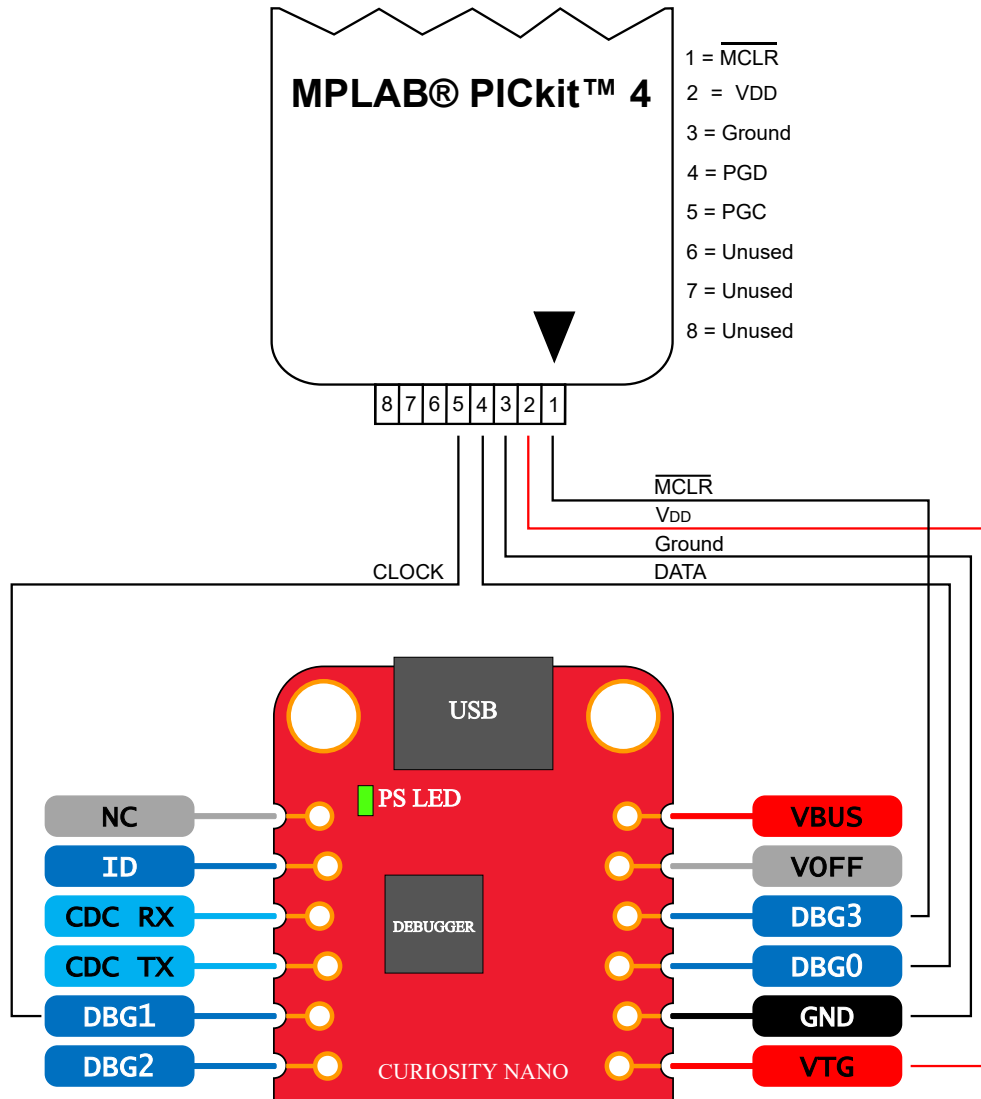

The MPLAB PICKit 4 In-circuit Debugger/Programmer is capable of delivering high voltage on the $\overline{\text{MCLR}}$ pin. R110 can be permanently damaged by the high voltage. If R110 is broken, the on-board debugger can not enter programming mode of the PIC16F18446, and will typically fail at reading the device ID.



To avoid contention between the external debugger and the on-board debugger, do not start any programming/debug operation with the on-board debugger through MPLAB® X IDE or mass storage programming while the external tool is active.

The Microchip Website

Microchip provides online support via our website at <http://www.microchip.com/>. This website is used to make files and information easily available to customers. Some of the content available includes:

- **Product Support** – Data sheets and errata, application notes and sample programs, design resources, user's guides and hardware support documents, latest software releases and archived software
- **General Technical Support** – Frequently Asked Questions (FAQs), technical support requests, online discussion groups, Microchip design partner program member listing
- **Business of Microchip** – Product selector and ordering guides, latest Microchip press releases, listing of seminars and events, listings of Microchip sales offices, distributors and factory representatives

Product Change Notification Service

Microchip's product change notification service helps keep customers current on Microchip products. Subscribers will receive email notification whenever there are changes, updates, revisions or errata related to a specified product family or development tool of interest.

To register, go to <http://www.microchip.com/pcn> and follow the registration instructions.

Customer Support

Users of Microchip products can receive assistance through several channels:

- Distributor or Representative
- Local Sales Office
- Embedded Solutions Engineer (ESE)
- Technical Support

Customers should contact their distributor, representative or ESE for support. Local sales offices are also available to help customers. A listing of sales offices and locations is included in this document.

Technical support is available through the website at: <http://www.microchip.com/support>

Microchip Devices Code Protection Feature

Note the following details of the code protection feature on Microchip devices:

- Microchip products meet the specification contained in their particular Microchip Data Sheet.
- Microchip believes that its family of products is one of the most secure families of its kind on the market today, when used in the intended manner and under normal conditions.
- There are dishonest and possibly illegal methods used to breach the code protection feature. All of these methods, to our knowledge, require using the Microchip products in a manner outside the operating specifications contained in Microchip's Data Sheets. Most likely, the person doing so is engaged in theft of intellectual property.
- Microchip is willing to work with the customer who is concerned about the integrity of their code.
- Neither Microchip nor any other semiconductor manufacturer can guarantee the security of their code. Code protection does not mean that we are guaranteeing the product as "unbreakable."

Code protection is constantly evolving. We at Microchip are committed to continuously improving the code protection features of our products. Attempts to break Microchip's code protection feature may be a violation of the Digital Millennium Copyright Act. If such acts allow unauthorized access to your software or other copyrighted work, you may have a right to sue for relief under that Act.

Legal Notice

Information contained in this publication regarding device applications and the like is provided only for your convenience and may be superseded by updates. It is your responsibility to ensure that your application meets with

your specifications. MICROCHIP MAKES NO REPRESENTATIONS OR WARRANTIES OF ANY KIND WHETHER EXPRESS OR IMPLIED, WRITTEN OR ORAL, STATUTORY OR OTHERWISE, RELATED TO THE INFORMATION, INCLUDING BUT NOT LIMITED TO ITS CONDITION, QUALITY, PERFORMANCE, MERCHANTABILITY OR FITNESS FOR PURPOSE. Microchip disclaims all liability arising from this information and its use. Use of Microchip devices in life support and/or safety applications is entirely at the buyer's risk, and the buyer agrees to defend, indemnify and hold harmless Microchip from any and all damages, claims, suits, or expenses resulting from such use. No licenses are conveyed, implicitly or otherwise, under any Microchip intellectual property rights unless otherwise stated.

Trademarks

The Microchip name and logo, the Microchip logo, Adaptec, AnyRate, AVR, AVR logo, AVR Freaks, BesTime, BitCloud, chipKIT, chipKIT logo, CryptoMemory, CryptoRF, dsPIC, FlashFlex, flexPWR, HELDO, IGLOO, JukeBlox, KeeLoq, Kleer, LANCheck, LinkMD, maXStylus, maXTouch, MediaLB, megaAVR, Microsemi, Microsemi logo, MOST, MOST logo, MPLAB, OptoLyzer, PackeTime, PIC, picoPower, PICSTART, PIC32 logo, PolarFire, Prochip Designer, QTouch, SAM-BA, SenGenuity, SpyNIC, SST, SST Logo, SuperFlash, Symmetricom, SyncServer, Tachyon, TempTrackr, TimeSource, tinyAVR, UNI/O, Vectron, and XMEGA are registered trademarks of Microchip Technology Incorporated in the U.S.A. and other countries.

APT, ClockWorks, The Embedded Control Solutions Company, EtherSynch, FlashTec, Hyper Speed Control, HyperLight Load, IntelliMOS, Libero, motorBench, mTouch, Powermite 3, Precision Edge, ProASIC, ProASIC Plus, ProASIC Plus logo, Quiet-Wire, SmartFusion, SyncWorld, Temux, TimeCesium, TimeHub, TimePictra, TimeProvider, Vite, WinPath, and ZL are registered trademarks of Microchip Technology Incorporated in the U.S.A.

Adjacent Key Suppression, AKS, Analog-for-the-Digital Age, Any Capacitor, AnyIn, AnyOut, BlueSky, BodyCom, CodeGuard, CryptoAuthentication, CryptoAutomotive, CryptoCompanion, CryptoController, dsPICDEM, dsPICDEM.net, Dynamic Average Matching, DAM, ECAN, EtherGREEN, In-Circuit Serial Programming, ICSP, INICnet, Inter-Chip Connectivity, JitterBlocker, KleerNet, KleerNet logo, memBrain, Mindi, MiWi, MPASM, MPF, MPLAB Certified logo, MPLIB, MPLINK, MultiTRAK, NetDetach, Omniscient Code Generation, PICDEM, PICDEM.net, PICkit, PICtail, PowerSmart, PureSilicon, QMatrix, REAL ICE, Ripple Blocker, SAM-ICE, Serial Quad I/O, SMART-I.S., SQI, SuperSwitcher, SuperSwitcher II, Total Endurance, TSHARC, USBCheck, VariSense, ViewSpan, WiperLock, Wireless DNA, and ZENA are trademarks of Microchip Technology Incorporated in the U.S.A. and other countries.

SQTP is a service mark of Microchip Technology Incorporated in the U.S.A.

The Adaptec logo, Frequency on Demand, Silicon Storage Technology, and Symmcom are registered trademarks of Microchip Technology Inc. in other countries.

GestIC is a registered trademark of Microchip Technology Germany II GmbH & Co. KG, a subsidiary of Microchip Technology Inc., in other countries.

All other trademarks mentioned herein are property of their respective companies.

© 2019, Microchip Technology Incorporated, Printed in the U.S.A., All Rights Reserved.

ISBN: 978-1-5224-5112-9

Quality Management System

For information regarding Microchip's Quality Management Systems, please visit <http://www.microchip.com/quality>.

Worldwide Sales and Service

| AMERICAS | ASIA/PACIFIC | ASIA/PACIFIC | EUROPE |
|---|---|--|---|
| <p>Corporate Office 2355 West Chandler Blvd. Chandler, AZ 85224-6199 Tel: 480-792-7200 Fax: 480-792-7277 Technical Support: http://www.microchip.com/support Web Address: http://www.microchip.com</p> <p>Atlanta Duluth, GA Tel: 678-957-9614 Fax: 678-957-1455</p> <p>Austin, TX Tel: 512-257-3370</p> <p>Boston Westborough, MA Tel: 774-760-0087 Fax: 774-760-0088</p> <p>Chicago Itasca, IL Tel: 630-285-0071 Fax: 630-285-0075</p> <p>Dallas Addison, TX Tel: 972-818-7423 Fax: 972-818-2924</p> <p>Detroit Novi, MI Tel: 248-848-4000</p> <p>Houston, TX Tel: 281-894-5983</p> <p>Indianapolis Noblesville, IN Tel: 317-773-8323 Fax: 317-773-5453 Tel: 317-536-2380</p> <p>Los Angeles Mission Viejo, CA Tel: 949-462-9523 Fax: 949-462-9608 Tel: 951-273-7800</p> <p>Raleigh, NC Tel: 919-844-7510</p> <p>New York, NY Tel: 631-435-6000</p> <p>San Jose, CA Tel: 408-735-9110 Tel: 408-436-4270</p> <p>Canada - Toronto Tel: 905-695-1980 Fax: 905-695-2078</p> | <p>Australia - Sydney Tel: 61-2-9868-6733</p> <p>China - Beijing Tel: 86-10-8569-7000</p> <p>China - Chengdu Tel: 86-28-8665-5511</p> <p>China - Chongqing Tel: 86-23-8980-9588</p> <p>China - Dongguan Tel: 86-769-8702-9880</p> <p>China - Guangzhou Tel: 86-20-8755-8029</p> <p>China - Hangzhou Tel: 86-571-8792-8115</p> <p>China - Hong Kong SAR Tel: 852-2943-5100</p> <p>China - Nanjing Tel: 86-25-8473-2460</p> <p>China - Qingdao Tel: 86-532-8502-7355</p> <p>China - Shanghai Tel: 86-21-3326-8000</p> <p>China - Shenyang Tel: 86-24-2334-2829</p> <p>China - Shenzhen Tel: 86-755-8864-2200</p> <p>China - Suzhou Tel: 86-186-6233-1526</p> <p>China - Wuhan Tel: 86-27-5980-5300</p> <p>China - Xian Tel: 86-29-8833-7252</p> <p>China - Xiamen Tel: 86-592-2388138</p> <p>China - Zhuhai Tel: 86-756-3210040</p> | <p>India - Bangalore Tel: 91-80-3090-4444</p> <p>India - New Delhi Tel: 91-11-4160-8631</p> <p>India - Pune Tel: 91-20-4121-0141</p> <p>Japan - Osaka Tel: 81-6-6152-7160</p> <p>Japan - Tokyo Tel: 81-3-6880-3770</p> <p>Korea - Daegu Tel: 82-53-744-4301</p> <p>Korea - Seoul Tel: 82-2-554-7200</p> <p>Malaysia - Kuala Lumpur Tel: 60-3-7651-7906</p> <p>Malaysia - Penang Tel: 60-4-227-8870</p> <p>Philippines - Manila Tel: 63-2-634-9065</p> <p>Singapore Tel: 65-6334-8870</p> <p>Taiwan - Hsin Chu Tel: 886-3-577-8366</p> <p>Taiwan - Kaohsiung Tel: 886-7-213-7830</p> <p>Taiwan - Taipei Tel: 886-2-2508-8600</p> <p>Thailand - Bangkok Tel: 66-2-694-1351</p> <p>Vietnam - Ho Chi Minh Tel: 84-28-5448-2100</p> | <p>Austria - Wels Tel: 43-7242-2244-39 Fax: 43-7242-2244-393</p> <p>Denmark - Copenhagen Tel: 45-4450-2828 Fax: 45-4485-2829</p> <p>Finland - Espoo Tel: 358-9-4520-820</p> <p>France - Paris Tel: 33-1-69-53-63-20 Fax: 33-1-69-30-90-79</p> <p>Germany - Garching Tel: 49-8931-9700</p> <p>Germany - Haan Tel: 49-2129-3766400</p> <p>Germany - Heilbronn Tel: 49-7131-72400</p> <p>Germany - Karlsruhe Tel: 49-721-625370</p> <p>Germany - Munich Tel: 49-89-627-144-0 Fax: 49-89-627-144-44</p> <p>Germany - Rosenheim Tel: 49-8031-354-560</p> <p>Israel - Ra'anana Tel: 972-9-744-7705</p> <p>Italy - Milan Tel: 39-0331-742611 Fax: 39-0331-466781</p> <p>Italy - Padova Tel: 39-049-7625286</p> <p>Netherlands - Drunen Tel: 31-416-690399 Fax: 31-416-690340</p> <p>Norway - Trondheim Tel: 47-72884388</p> <p>Poland - Warsaw Tel: 48-22-3325737</p> <p>Romania - Bucharest Tel: 40-21-407-87-50</p> <p>Spain - Madrid Tel: 34-91-708-08-90 Fax: 34-91-708-08-91</p> <p>Sweden - Gothenberg Tel: 46-31-704-60-40</p> <p>Sweden - Stockholm Tel: 46-8-5090-4654</p> <p>UK - Wokingham Tel: 44-118-921-5800 Fax: 44-118-921-5820</p> |