

Industrial smart sensor kit based on L6364W dual IO-Link device transceiver

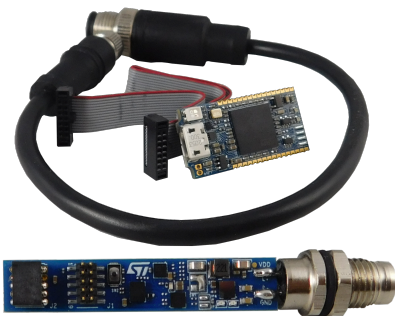

Features

- Kit content:
 - STEVAL-IOD004V1 (45.8 x 8.3 mm) main board with shape easy to be integrated in industrial sensors housing (not available for separate sale)
 - [STLINK-V3MINI](#) programmer and debugger tool
 - M8-M12 industrial connector adapter including a 20 cm cable
 - 14-pin flat cable
- Main board features:
 - Industrial sensor node based on [STM32G071EB](#) (mainstream Arm® Cortex®-M0+ RISC core MCU operating at up to 64 MHz frequency), [L6364W](#) (dual channel transceiver IC for SIO and IO-Link sensor applications), [IIS2MDC](#) (high accuracy, ultra-low-power, 3-axis digital output magnetometer) and [ISM330DHCX](#) (iNEMO inertial module with machine learning core, and finite state machine with digital output for industrial applications)
 - Runs an IO-Link v.1.1 demo-stack and MEMS control software, included in the companion package [STSW-IOD04K](#) together with the IODD file
 - Operating voltage range 7 to 32 V
 - Four-pole M8 industrial standard connector
 - [L6364W](#) embedded DC-DC converter provides 3.3 V supply for all on-board ICs
 - General-purpose LEDs for transmission, programming/debugging, warning, and status
 - Jumpers for CQ and DIO selection in independent or joint mode
 - Switch for transmission mode selection (transparent, single, or multioctet)
 - Reset button
 - 10-pin connector for sensor expansion options
 - SWD connector for debugging and programming capability
 - Protections against surge pulse (up to ± 3APK with 500 Ω coupling) and reverse polarity
 - EMC and EMI tested according to standard requirements
 - RoHS compliant

Product summary	
Industrial smart sensor kit based on L6364W dual IO-Link device transceiver	STEVAL-IOD04KT1
Software pack for STEVAL-IOD04KT1 with IO-Link stack v1.1, IODD, and control software for industrial sensors	STSW-IOD04K
Dual channel IO-Link device transceiver in CSP package	L6364W
Applications	Factory automation Industrial sensors

Description

The [STEVAL-IOD04KT1](#) is a reference design kit that exploits the features of the [L6364W](#) IO-Link dual-channel device transceiver.

The kit consists of the STEVAL-IOD004V1 main board (not available for sale), the [STLINK-V3MINI](#) programmer and debugger tool, a 14-pin flat cable, and an M8 to M12 standard industrial connector adapter.

The kit acts as a modern smart industrial sensor to be connected to a master IO-Link hub (or a suitable PLC interface).

The power supply for the MCU, sensors, and other logic devices derives from the DC-DC converter controller embedded in the [L6364W](#).

The on-board [STM32G071EB](#) microcontroller runs an IO-Link demo stack v.1.1, which controls the IO-Link communication, and the software code that manages the [L6364W](#) transceiver and the MEMS industrial sensors.

The tiny dimensions of the main board have been achieved thanks to the small sizes of the CSP package options of [L6364W](#) and [STM32G071EB](#).

Connect the main board to an IO-Link master via the adapter and the M8 connector included in the kit for normal operation. Connect the same board to the [STLINK-V3MINI](#) through the flat cable only if you want to program the [STM32G071EB](#) with a new firmware.

1 Solution overview

Target of this reference design are IO-Link based applications, i.e. smart industrial sensors featuring capabilities like easy configurability, remote monitoring, reduced wiring, advanced diagnostics and easy device replacement. To ensure the objective to be easily integrated in the field, the main board STEVAL-IOD004V1 has been designed with low ICs components count: with this in mind, smart sensing applications can benefit from the dual-channel transceiver L6364W, for example a robotic arm can be monitored (vibration, compensation) through the ISM330DHCX inertial module while the magnetic field can be detected through the IIS2MDC, providing a warning along the supplementary channel.

Figure 1. STEVAL-IOD004V1 functional block diagram

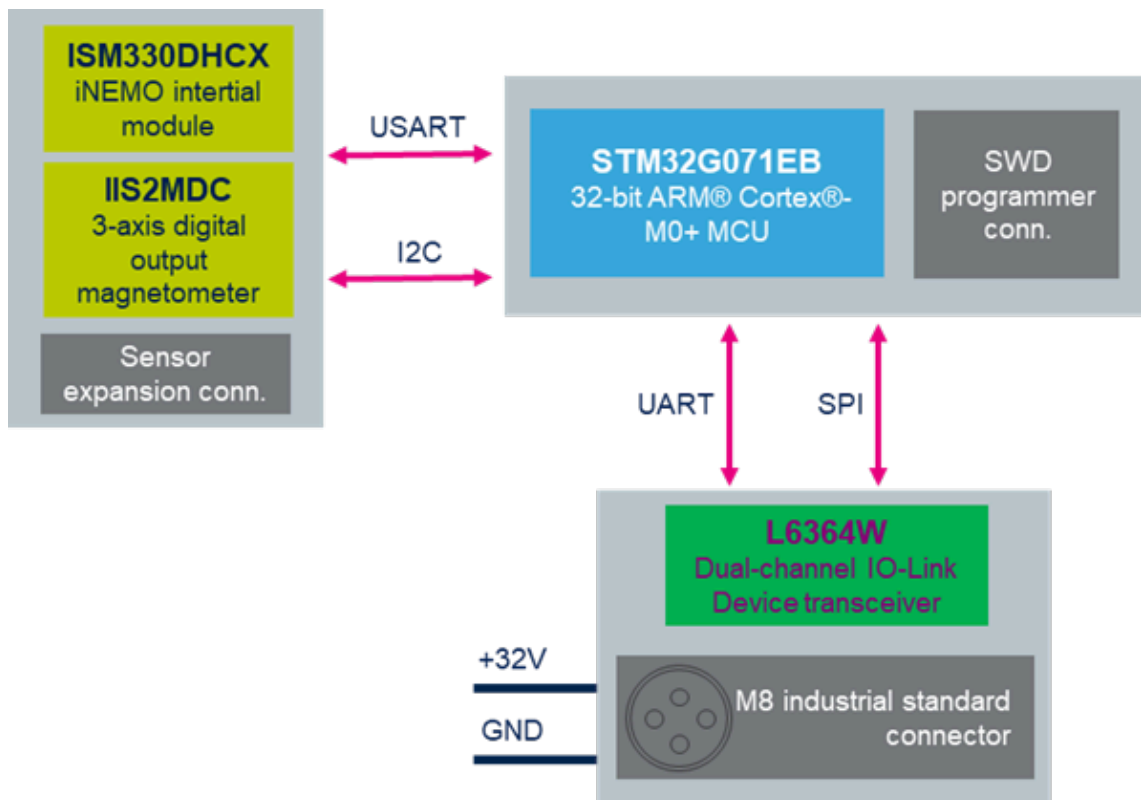

2 Schematic diagrams

Figure 2. STEVAL-IOD004V1 (main board) circuit schematic (1 of 4)

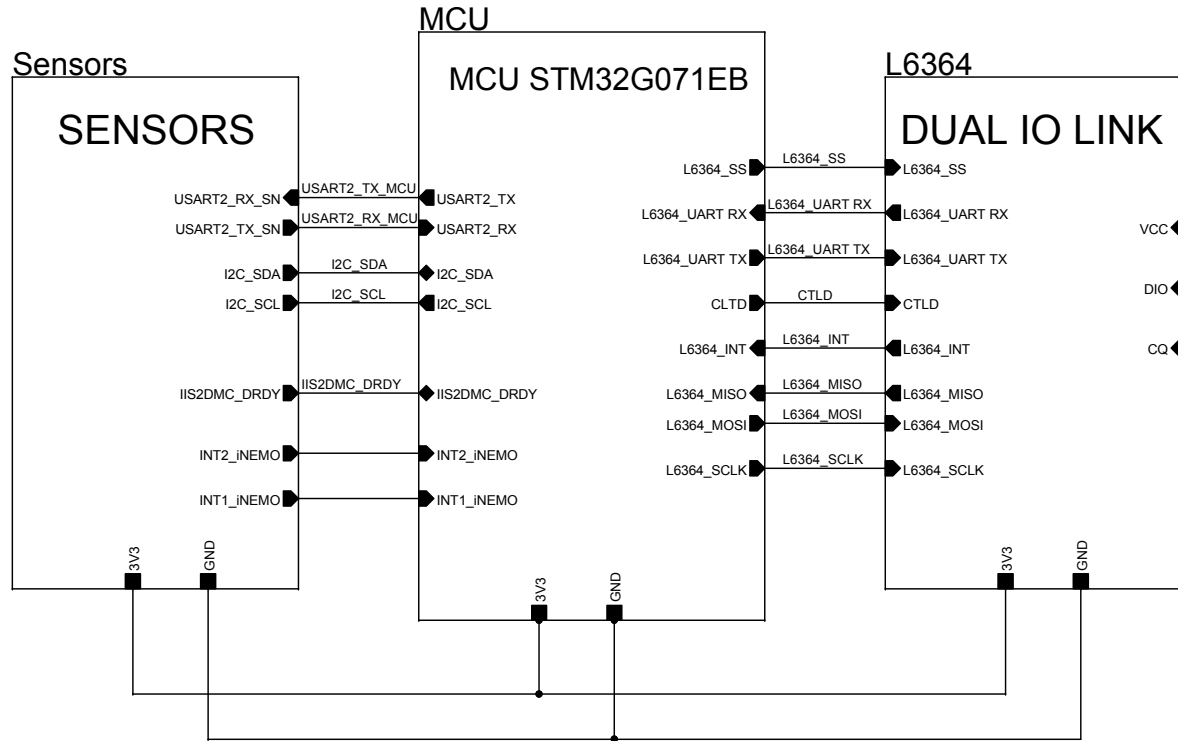

Figure 3. STEVAL-IOD004V1 (main board) circuit schematic (2 of 4)

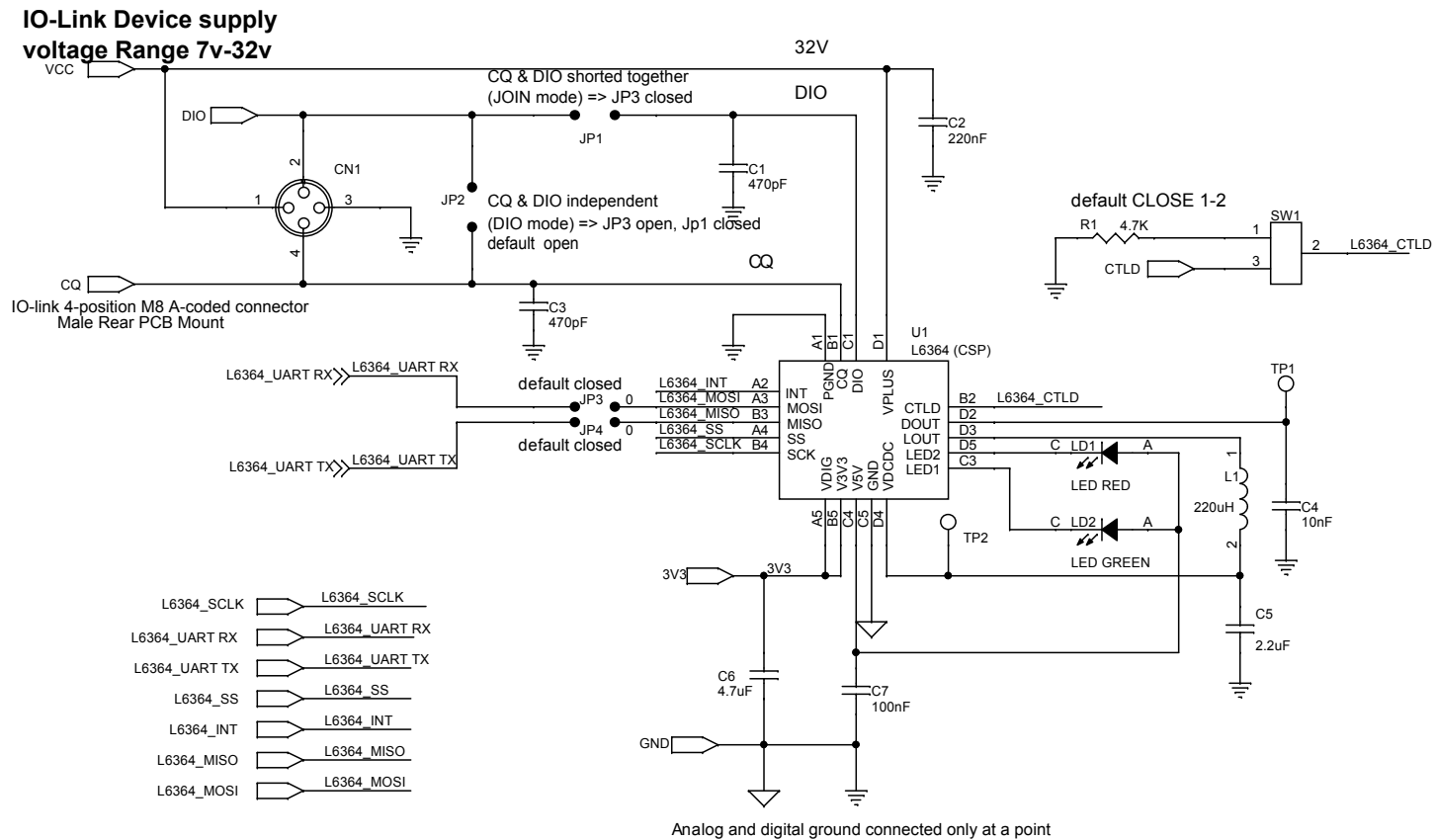

Figure 4. STEVAL-IOD004V1 (main board) circuit schematic (3 of 4)

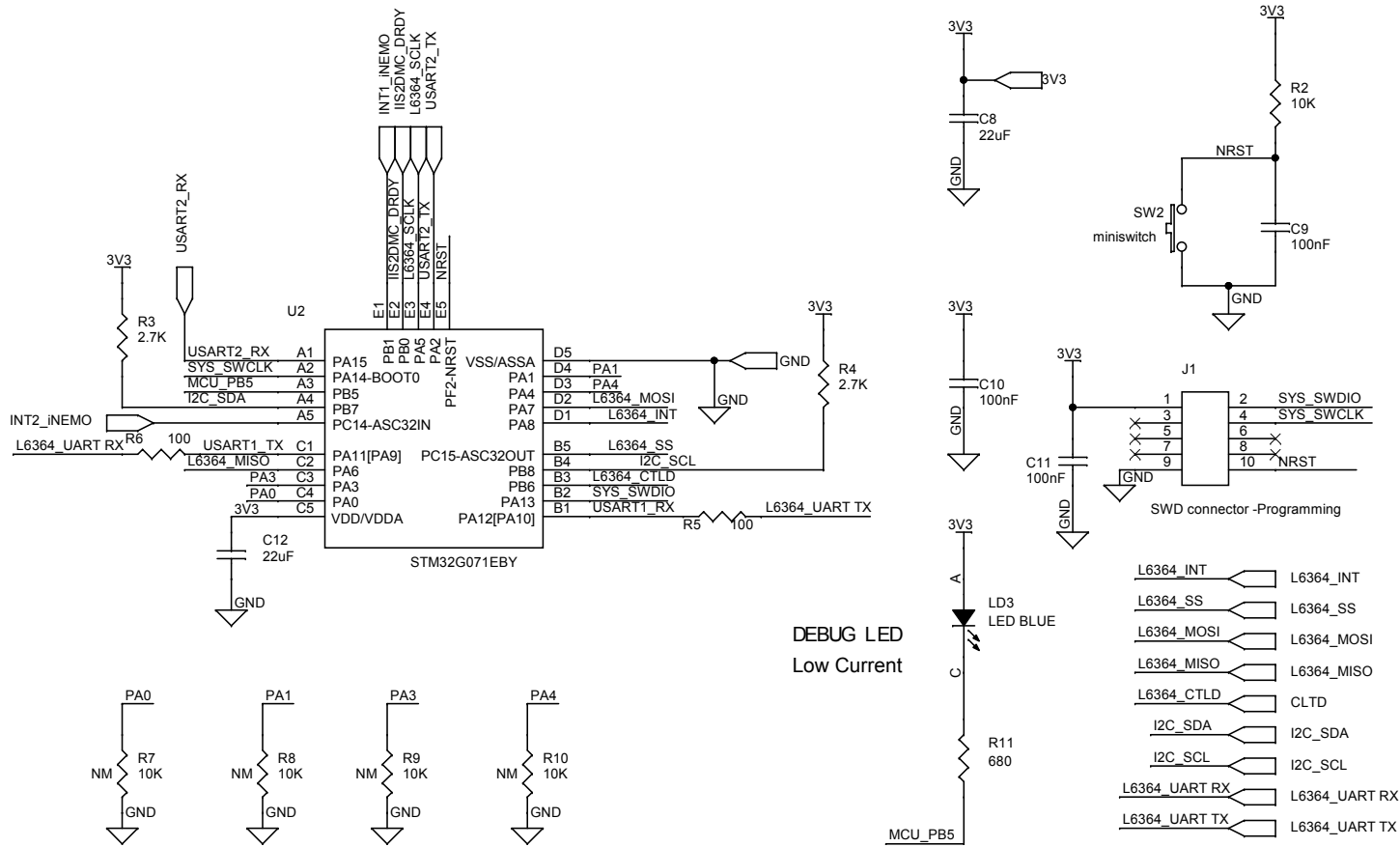
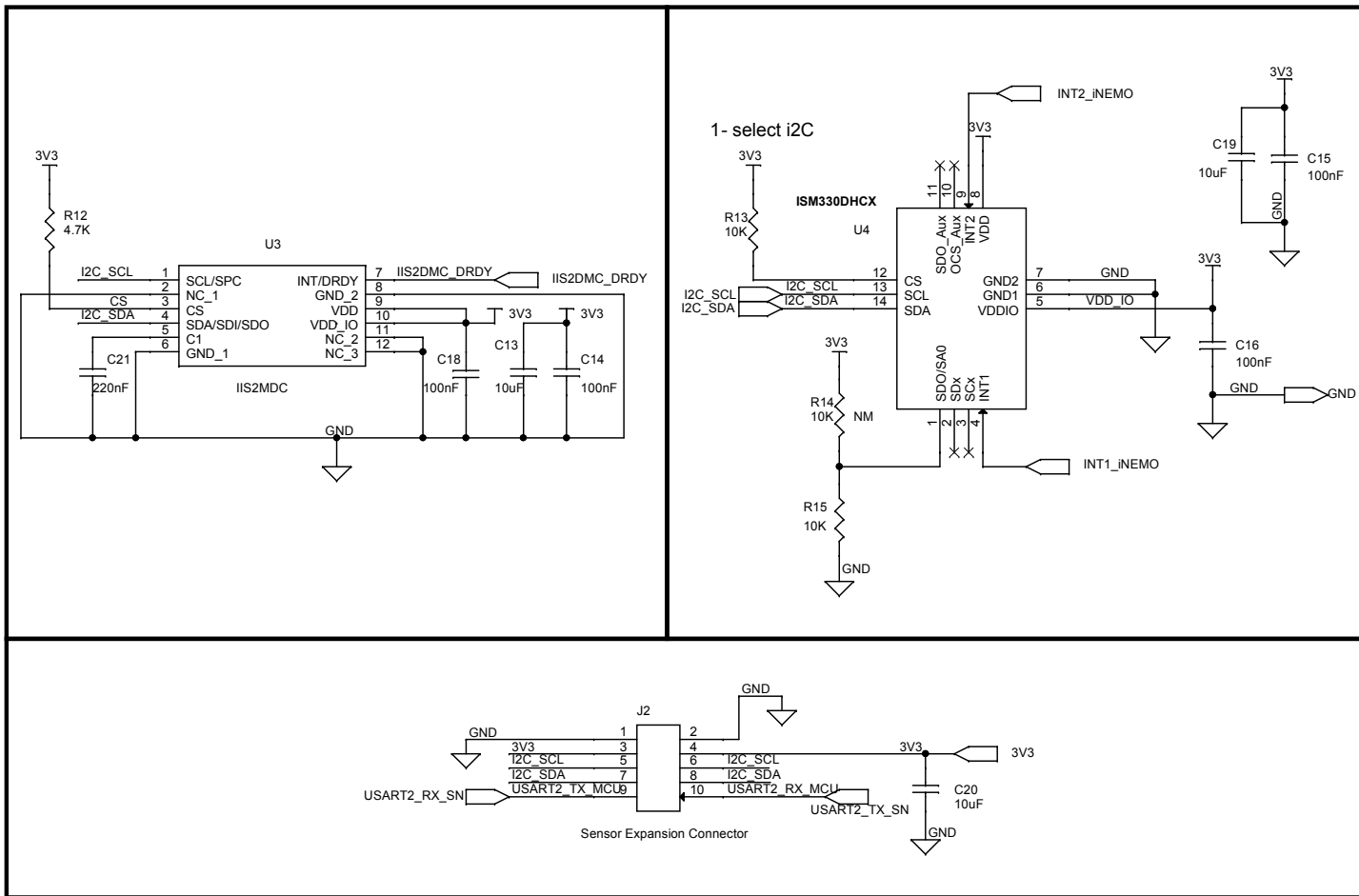

Figure 5. STEVAL-IOD004V1 (main board) circuit schematic (4 of 4)



3 Board versions

Table 1. STEVAL-IOD04KT1 versions

Finished good	Schematic diagrams	Bill of materials
STEVAL-IOD04KT1A ⁽¹⁾	STEVAL-IOD04KT1A schematic diagrams	STEVAL-IOD04KT1A bill of materials

1. This code identifies the STEVAL-IOD04KT1 evaluation board first version.

Revision history

Table 2. Document revision history

Date	Revision	Changes
27-Oct-2021	1	Initial release.

IMPORTANT NOTICE – PLEASE READ CAREFULLY

STMicroelectronics NV and its subsidiaries (“ST”) reserve the right to make changes, corrections, enhancements, modifications, and improvements to ST products and/or to this document at any time without notice. Purchasers should obtain the latest relevant information on ST products before placing orders. ST products are sold pursuant to ST’s terms and conditions of sale in place at the time of order acknowledgement.

Purchasers are solely responsible for the choice, selection, and use of ST products and ST assumes no liability for application assistance or the design of Purchasers’ products.

No license, express or implied, to any intellectual property right is granted by ST herein.

Resale of ST products with provisions different from the information set forth herein shall void any warranty granted by ST for such product.

ST and the ST logo are trademarks of ST. For additional information about ST trademarks, please refer to www.st.com/trademarks. All other product or service names are the property of their respective owners.

Information in this document supersedes and replaces information previously supplied in any prior versions of this document.

© 2021 STMicroelectronics – All rights reserved