

MLX90392

3D Magnetometer

Datasheet

Features and Benefits

- **3-axis** magnetometer device suitable for compass and position sensors applications
Triaxis→ Hall Technology
- Suitable for space constrained applications (only 2 x 2,5 x 0.4mm)
- Compatible with I2C FM+
- Low power application – Power down current of 1.5uA
- Supply voltage of 1.8V
- Ambient temperature range from -40degC to 85degC
- Digital Output
 - 16-bit Magnetic (XYZ)
 - 16-bit Temperature
- At runtime selectable modes
 - Single Measurement
 - Continuous Mode up to 1.4kHz (XYZ)
- RoHS Compliant & Green Package

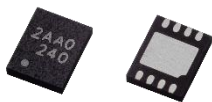

UTDFN-8

Application Examples

- Power tools - Screwdriver trigger
- Home security - door/ window opening detection
- Knobs for White goods
- PC peripheral – Mouse roller
- Gaming joystick
- Anti-tamper for energy metering

Description

The device, especially designed for micropower applications, measures magnetic fields along the 3 axis (X, Y being in a plane parallel to the surface of the die, Z being perpendicular to the surface). Those measurements and the IC temperature are converted into 16-bit words which are transferred upon request over I2C communication channel. The device transmits compensated raw measurement data.

The MLX90392 is available in 2 magnetic versions:

- +/-5mT range for Low noise applications
- +/-50mT range for position sensor applications

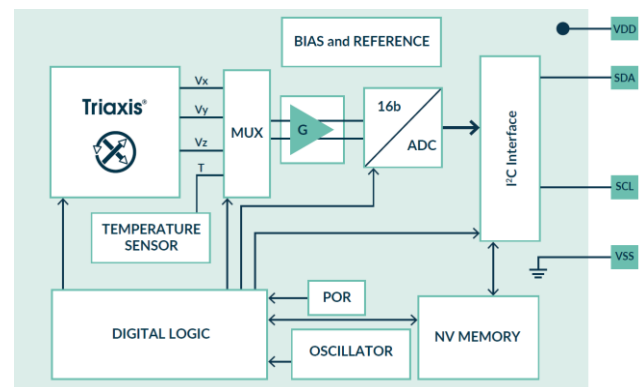

1. Ordering information

Ordering Code	Temperature	Package	Type	Output	Packing
MLX90392ELQ-AAA-010-RE	-40°C to 85°C	UTDFN-8 2x2.5	+/-5mT	I2C	Reel
MLX90392ELQ-AAA-011-RE	-40°C to 85°C	UTDFN-8 2x2.5	+/-50mT	I2C	Reel

Table 1 – Ordering codes

Legend:

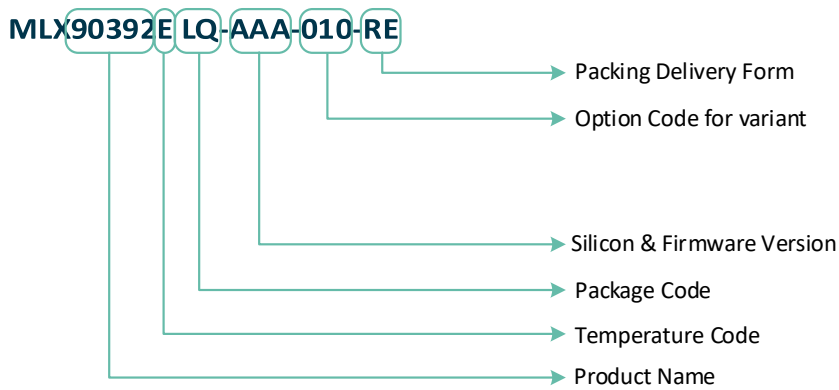

2. Contents

Contents

Features and Benefits.....	1
Application Examples	1
Description	1
1. Ordering information.....	2
2. Contents	3
3. Glossary of terms.....	5
4. Pins Description and Block diagram	6
4.1. Pins description	6
5. Block Diagram.....	6
6. Conditions and Specifications.....	7
6.1. Absolute Maximum Ratings (AMR)	7
6.2. Operating Conditions.....	7
6.2.1. General Operating Conditions	7
6.2.2. Electrical Operating Conditions	7
6.2.3. Magnetic Operating Conditions.....	7
6.2.4. I2C Timings Conditions	8
6.3. Electrical Specifications	9
6.4. Magnetic Specifications.....	10
6.5. Timing Specifications	12
6.6. Accuracy Specifications	14
7. Functional Description & Interfaces	15
7.1. Operating Modes.....	15
7.1.1. Single measurement mode.....	15
7.1.2. Continuous measurement Mode	17
7.1.3. Self-test Mode (recommended for version xxx - 010).....	20
7.1.4. Idle mode.....	22
7.2. Output protocol (I2C) description	22
7.2.1. Command implementation	22
7.3. Memory items description	24
7.3.1. Memory Structure	24
7.3.2. I/O registers description	24
7.4. Flowchart.....	29
7.5. Performance Graphs.....	30
7.5.1. Noise performance	30

7.5.1.1.1. Version 010 - Without temperature compensation	30
7.6. Temperature compensation	33
8. Application Information	34
8.1. Recommended Application Diagram	34
9. Package and Manufacturability information	34
9.1. ESD precaution	34
9.2. Package information	35
9.2.1. Dimensions	35
9.2.2. Sensing element placement	36
9.2.3. Marking	37
9.3. Standard information on soldering processes	37
10. References	38
10.1. List of figures	38
10.2. List of tables	38
11. Revision History	39
12. Disclaimer	40

3. Glossary of terms

Term	Description
NC	Not Connected
ADC	Analog-to-digital converter
LSB	Least significant bit
MSB	Most significant bit
Gauss (G)	Units for magnetic flux density – 1mT = 10G
RMS	Root mean square
POR	Power On reset
NV	Non-volatile
DSP	Digital signal processing

4. Pins Description and Block diagram

4.1. Pins description

Pin #	Name (I ² C)	Description
1	SDA	[I/O] Bus Data
2	VDD	[S] Supply
3	VSS	[S] Ground
4	SCL	[I] Bus clock
5	Not used	Not connected
6	Not used	Not connected
7	Not used	Not connected
8	Not used	Not connected

Table 2 – Pin description

5. Block Diagram

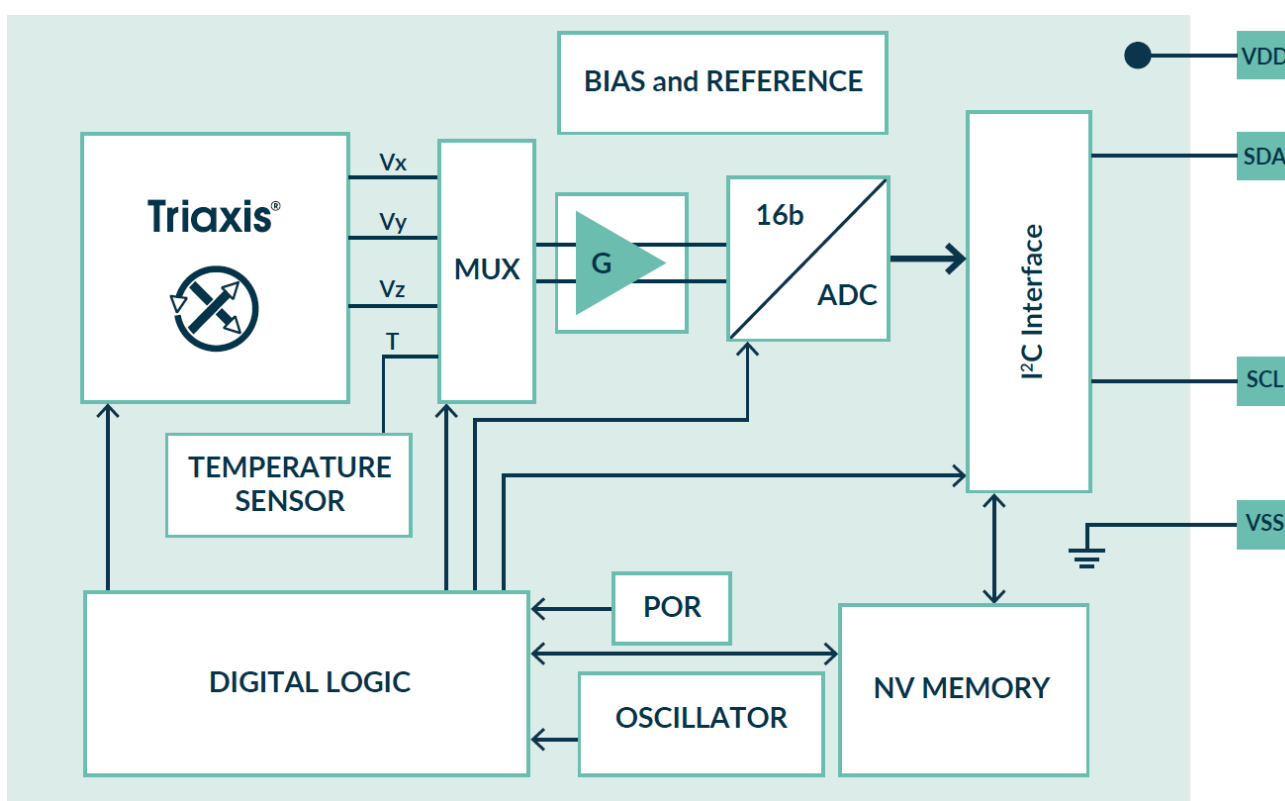

Figure 1: IC block diagram

6. Conditions and Specifications

6.1. Absolute Maximum Ratings (AMR)

Operating Characteristics, $T_A = -40^{\circ}\text{C}$ to 85°C (unless otherwise specified)

Parameter	Symbol	Min.	Typ.	Max.	Unit	Conditions
Supply Voltage	VS			2.3	V	<48h
Reverse voltage protection	V _{REV}			-0.3	V	Room temp, <48h
Output voltage	V _{SDA} , V _{SCL}			2.3	V	<48h
Reverse output voltage	V _{SDAREV}			-0.3	V	
Reverse clock output voltage	V _{SCLREV}			-0.3	V	
ESD HBM (all pins)					kV	
Operating Temperature	T _A	-40		+85	°C	
Junction Temperature	T _{JUNC}			+85	°C	
Storage Temperature	T _{storage}	-40		150	°C	
Thermal resistance	R _{thja}		230		K/W	Junction to ambient 1s0p board
			40		K/W	Junction to ambient multi layered pcb
Thermal resistance	R _{thjc}		3.4		K/W	Junction to case
Magnetic Flux density		-1		1	T	

Table 3– Absolute Maximum Ratings

Exceeding the absolute maximum ratings may cause permanent damage. Exposure to absolute maximum-rated conditions for extended periods may affect device reliability.

6.2. Operating Conditions

6.2.1. General Operating Conditions

Parameter	Symbol	Min.	Typ.	Max.	Unit	Conditions
Operating Temperature	T _A	-40		+85	°C	
Storage Temperature	T _{storage}	-40		150	°C	

Table 4 – General operating conditions

6.2.2. Electrical Operating Conditions

Parameter	Symbol	Min.	Typ.	Max.	Unit	Conditions
Supply Voltage	VS	1.65	1.8	1.95	V	

Table 5 – Electrical Operating conditions

6.2.3. Magnetic Operating Conditions

Parameter	Symbol	Min.	Typ.	Max.	Unit	Conditions
Magnetic Flux density		-5		5	mT	version XXX-010
Magnetic Flux density		-50		50	mT	version XXX-011

Table 6 – Magnetic Operating conditions

6.2.4. I2C Timings Conditions

Electrical Parameter	Symbol	I ² C Standard Mode		I ² C Fast Mode Plus		Unit
		Min.	Max.	Min.	Max.	
SCL Clock Frequency	f (SCL)	0	100	0	1000	kHz
SCL Clock Low Time	t _w (SCLL)	4.7		0.5		μs
SCL Clock High Time	t _w (SCLH)	4		0.26		μs
SDA Setup Time	t _{su} (SDA)	250		50		ns
SDA Data Hold Time	t _h (SDA)	0	3.45	0	0.45	μs
START Condition Hold Time	t _h (ST)	4		0.26		μs
REPEATED START Condition Setup Time	t _{su} (SR)	4.7		0.26		μs
STOP Condition Setup Time	t _{su} (SP)	4		0.26		μs
Bus Free Time Between STOP and START Condition	t _w (SP:ST)	4.7		0.5		μs

Table 7: General I²C Timing Specification

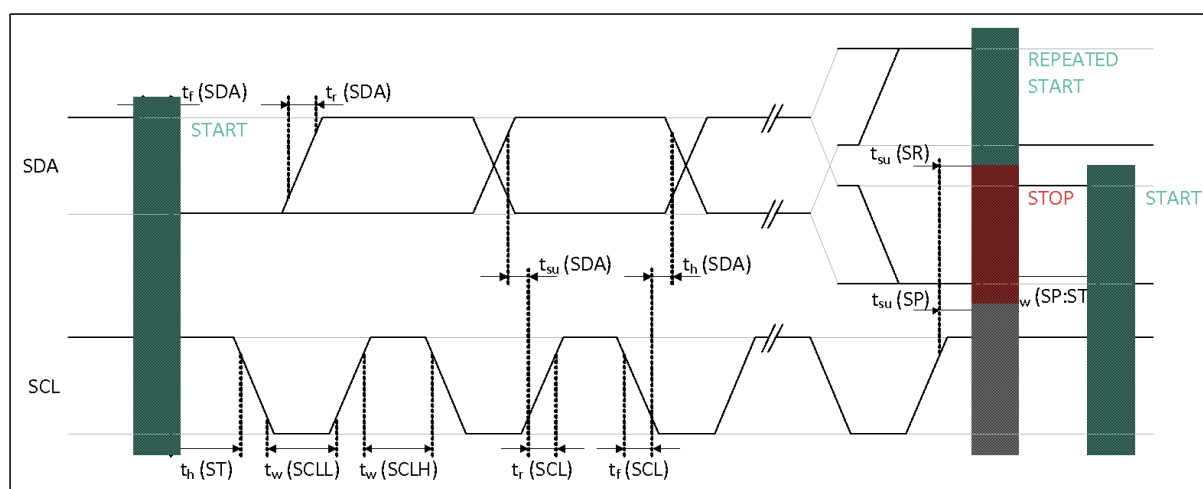

Figure 2: I²C Timing Diagram

6.3. Electrical Specifications

Operating Characteristics, $T_A = -40^{\circ}\text{C}$ to 85°C (unless otherwise specified)

Parameter	Symbol	Min.	Typ.	Max.	Unit	Conditions
Power On Reset (rising edge)	V_{POR_LH}	1.44	1.5	1.55	V	
Power On Reset (falling edge)	V_{POR_HL}	1.35	1.4	1.45	V	
Conversion Current	$I_{DD,CONVXY}$	2.2	2.7	3.5	mA	XY axis - Version 010
	$I_{DD,CONVZ}$	2.7	3.6	5.2	mA	Z axis - Version -010
Conversion Current	$I_{DD,CONVXY}$	1.4	1.8	2.7	mA	XY axis - Version 011
	$I_{DD,CONVZ}$	1.9	2.8	4.3	mA	Z axis - Version -011
Conversion current	$I_{DD,CONVT}$	0.6	0.73	0.85	mA	Temperature
Counting state current	$I_{DD,CNT}$	6	11	16	μA	
Idle current	$I_{DD,IDLE}$	0.4	1.5	3	μA	
Average current	$I_{DD,AVG100-0}$	1.8	2.3	3.2	mA	Version xxx-010 Continuous mode XYZT, OSR_HALL=1 DIG_FILTXY=4 DIG_FILTZ=5 DIG_FILT_TEMP=1 OSR_TEMP=1 Temp Comp enabled
100Hz refresh						
Average current	$I_{DD,AVG100-1}$	1.2	1.7	2.7	mA	VersionXXX-011 Continuous mode XYZT, OSR_HALL=1 DIG_FILTXY=4 DIG_FILTZ=5 DIG_FILT_TEMP=1 OSR_TEMP=1 Temp Comp enabled
100Hz refresh						
Average current	$I_{DD,AVG100-1}$	0.7	0.95	1.5	mA	Version xxx-011 Continuous mode XYZT, OSR_HALL=1 DIG_FILTXY=3 DIG_FILTZ=4 DIG_FILT_TEMP=1 OSR_TEMP=1 Temp Comp enabled
100Hz refresh						
Average current	$I_{DD,AVG200-0}$	1.8	2.45	3.5	mA	Version xxx-010 Continuous mode XYZT, OSR_HALL=1 DIG_FILTXY=3 DIG_FILTZ=4 DIG_FILT_TEMP=1 OSR_TEMP=1 Temp Comp enabled
200Hz refresh						
Average current	$I_{DD,AVG200-1}$	1.3	1.85	2.8	mA	Version xxx-011 Continuous mode XYZT, OSR_HALL=1 DIG_FILTXY=3 DIG_FILTZ=4 DIG_FILT_TEMP=1 OSR_TEMP=1 Temp Comp enabled
200Hz refresh						

Parameter	Symbol	Min.	Typ.	Max.	Unit	Conditions
Temperature sensor resolution ⁽¹⁾	TRES	48	50	52	LSB16/°C	
Temperature sensor accuracy	TLIN	-3		3	°C	+/-3sigma
Input Level High ⁽²⁾	VIH	56	59	63	%VDD	SDA, SCL
Input Level Low ⁽²⁾	VIL	43	48	54	%VDD	SDA, SCL
Input Level Hysteresis	VIHYST	5	11	17	%VDD	SDA, SCL
Input Capacitance ⁽²⁾	Cin		5	10	pF	SDA, SCL
Output Level Low	VOL		0.5	1	%VDD	SDA (Static, 1mA load)
Output on resistance	Rdson	5	8	14	ohms	+/-3sigma
Output leakage current			0.1	0.3	uA	
ESD HBM				2	kV	All pins
ESD CDM				0.5	kV	All pins

Table 8 – Electrical Operating conditions

6.4. Magnetic Specifications

Operating Characteristics, T_A = -40°C to 85°C (unless otherwise specified)

Parameter	Symbol	Min.	Typ.	Max.	Unit	Conditions
XY Magnetic sensitivity	SENS _{XY}	0.135	0.15	0.165	μT/LSB	version xxx-010 version xxx-011 room temperature
		1.33	1.5	1.67		
Z Magnetic Sensitivity	SENS _Z	0.135	0.15	0.165	μT/LSB	version xxx-010 version xxx-011 room temperature
		1.33	1.5	1.67		
Magnetic measurement range	B _{RANGE}	±4421	±4912	±5403	μT	version xxx-010 version xxx-011 room temperature
		±43560	±49128	±54696		
RMS Noise	N _{XYZ}		2.2	2.4	μTrms	version xxx-010 with temperature compensation – 5ms conv time (DIG_FILTXY=3 DIG_FILTZ=4, OSR_HALL=1), room temperature
RMS Noise	N _{XYZ}		1.5	1.7	μTrms	version xxx-010 without temperature compensation 5ms conv time (DIG_FILTXY=3 DIG_FILTZ=4, OSR_HALL=1), room temperature

¹ The data format is 2's complement with 0 lsb corresponding to 0degC

² This specification relates to the sensor and not the I2C bus

Parameter	Symbol	Min.	Typ.	Max.	Unit	Conditions
RMS Noise	N_{XYZ}		11	12	μTrms	version xxx-011 without temperature compensation – 5ms conv time (DIG_FILTXY=3 DIG_FILTZ=4, OSR_HALL=1), room temperature
RMS Noise	N_{XYZ}		20	21	μTrms	version xxx-011 with temperature compensation - 5ms conv time (DIG_FILTXY=3 DIG_FILTZ=4, OSR_HALL=1), room temperature
Sensitivity drift	SENS_{THD}	-10		10	%	vs. $T_a=35\text{degC}$
Hysteresis	B_h	200			μT	

Table 9 – Magnetic Specifications

6.5. Timing Specifications

Operating Characteristics, $T_A = -40^{\circ}\text{C}$ to 85°C (unless otherwise specified)

Parameter	Symbol	Min.	Typ.	Max.	Unit	Conditions
Output refresh rate ⁽³⁾	Fr1	10	100	700	Hz	With temperature compensation ⁽⁴⁾
	Fr2			1400	Hz	Without temperature compensation ⁽⁴⁾
Oscillator trimming accuracy	TOSC_TRIM	-5	0.5	5	%	
Oscillator Thermal drift	TOSC_THD	-5	0	5	%	
Magnetic axis conversion time ⁽⁵⁾	T _{CONVM}	105	111	117	μs	Time per axis DIG_FILT=0, OSR=0
	T _{CONVM}	202	213	224	μs	Time per axis DIG_FILT=0, OSR=1
	T _{CONVM}	912	960	1008	μs	Time per axis DIG_FILT=3, OSR=1
	T _{CONVM}	13.1	13.8	14.5	ms	Time per axis DIG_FILT=7, OSR=1
Start up time	TStartup		0.15	1.2	ms	Reset to idle mode
	TDSP	360	380	400	μs	with temp compensation enabled ⁽³⁾
DSP Time		220	235	250	μs	with temp compensation disabled ⁽³⁾

Table 10 – Timing specifications

³ Fr1 and Fr2 are defined as the period between two set of measurements. It is relevant for the Continuous measurement mode and is defined by the parameter MODE[3:0]. TREFRESH is adjustable with the following settings: 10Hz, 20Hz, 50Hz, 100Hz, 200Hz, 500Hz and 1.4kHz. The default value in the non-volatile memory is 100Hz.

⁴ The temperature compensation can be enabled or disabled by the user.

⁵ This conversion time is defined as the time to acquire a single axis of the magnetic flux density. When measuring XYZ, they are obtained through time-multiplexing. The conversion time is programmable through DIG_FILT for magnetic and temperature conversion. The total conversion time is obtained by summing up the magnetic & temperature conversion time.

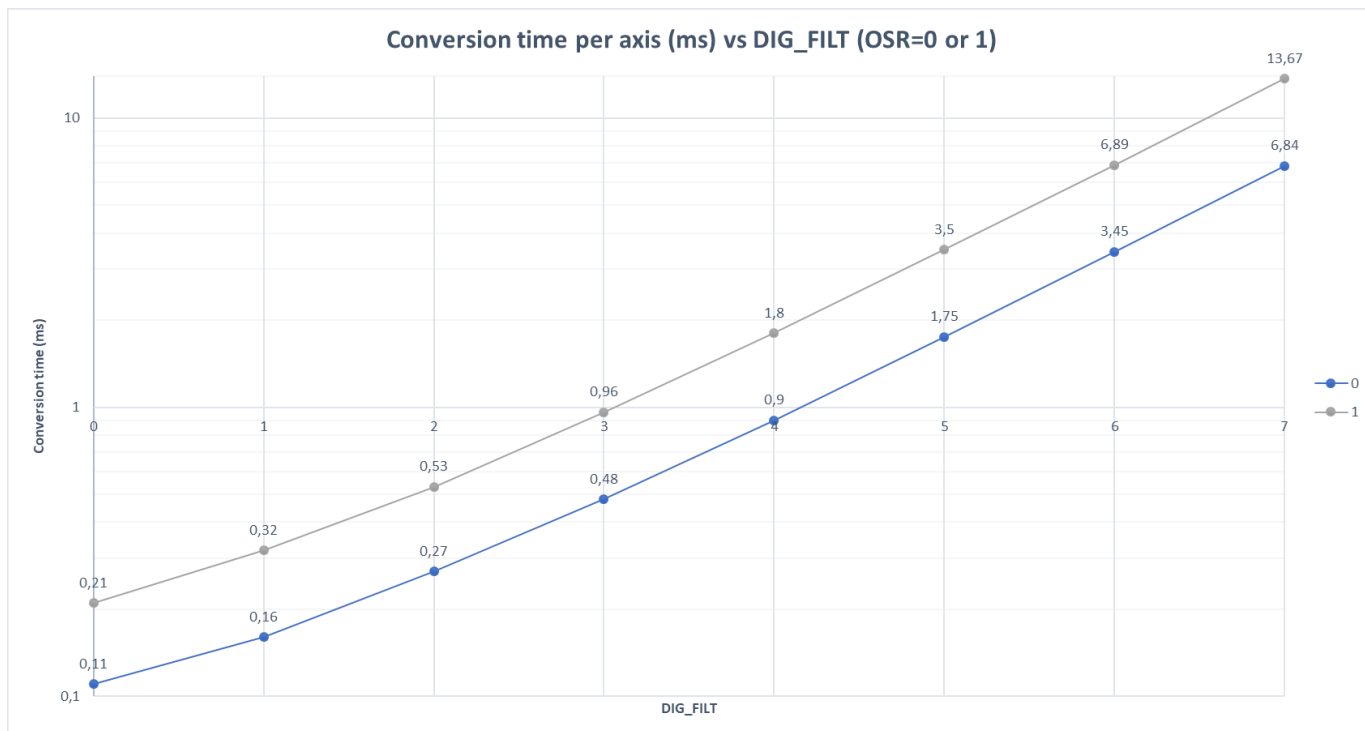

Figure 3: Conversion time

The above graph can be expressed with the following formula:

$$T_{\text{conv}}(\text{DIG_FILT}) = \frac{\text{OSR}}{F_{\text{clk}}} \cdot (2^{\text{DIG_FILT}+2} + 4) \quad F_{\text{clk}} = 2.4\text{MHz} \quad \text{typical}$$

6.6. Accuracy Specifications

Operating Characteristics, $T_A = -40^{\circ}\text{C}$ to 85°C (unless otherwise specified). All specifications in this chapter are given with +/- 3 sigma.

Parameter	Symbol	Min.	Typ.	Max.	Unit	Conditions
Resolution ⁽⁶⁾			16		bits	XYZ
Offset ⁽⁷⁾	O _{FFSX}	-1100	-200	700	LSB ₁₆	Version xxx-010 Output at 0Gauss. Room temperature
	O _{FFSY}	-1100	-200	700		
	O _{FFSZ}	-300	300	900		
Offset thermal drift X-axis		-840		1030	LSB ₁₆	Version xxx-010 vs. 35degC
Offset thermal drift Y-axis		-750		870		
Offset thermal drift Z-axis		-440		470		
Offset ⁽⁷⁾	O _{FFSX}	-150	40	220	LSB ₁₆	Version xxx- 011 Output at 0Gauss. Room temperature
	O _{FFSY}	-330	-130	70		
	O _{FFSZ}	-340	80	500		
Offset thermal drift X-axis		-120		90	LSB ₁₆	Version xxx-011 vs. 35degC
Offset thermal drift Y-axis		-100		120		
Offset thermal drift Z-axis		-220		190		
Mismatch on the raw signals X, Y and Z	S _{MISMXY}	-5	-1	2	%	Version xxx-010
	S _{MISMXZ}	-5	-2	1		
	S _{MISMYZ}	-3	-1	1		
Parameter	Symbol	Min.	Typ.	Max	Units	Conditions
Thermal drift of sensitivity mismatch		-110		225	ppm/°C	Version xxx-010
Mismatch on the raw signals X, Y and Z	S _{MISMXY}	-3	1	5	%	Version xxx-011
	S _{MISMXZ}	7	10	13		
	S _{MISMYZ}	6	9	11		
Thermal drift of sensitivity mismatch		-140		265	ppm/°C	Version xxx-011
Cross-axis sensitivity ⁽⁸⁾	S _{XYi}	-1.8	0.5	2.6	%	Version xxx-010 (guaranteed by characterization / not by final testing)
	S _{YXi}	-2.7	-0.7	1.3		
	S _{XZi}	-8.0	-3.2	1.8		
	S _{ZXi}	-5.0	-0.2	4.5		
	S _{YZi}	-5.7	0.5	6.6		
	S _{ZYi}	-4.8	0.9	3		
Cross-axis sensitivity ⁽⁸⁾	S _{XYi}	-1.5	0.2	1.9	%	Version xxx-011 (guaranteed by characterization / not by final testing)
	S _{YXi}	-1.7	0.0	1.8		
	S _{XZi}	-1.3	4.9	12.4		
	S _{ZXi}	-3.0	1.0	5.6		
	S _{YZi}	-9.6	-6.3	-4.1		
	S _{ZYi}	-3.3	-1.6	-0.5		

Table 11 – Accuracy specifications

⁶ The data format is 2's complement, further explanation can be found on chapter 7.1.2.6, Table 12

⁷ Value of measurement data register on shipment test without applying magnetic field on purpose

⁸ The cross axis sensitivity is measured by applying a force field on one axis and measured on another axis. For instance, S_{XYi} means that a field was applied along X axis and measured along Y axis.

7. Functional Description & Interfaces

7.1. Operating Modes

MLX90392 has the following Application modes

1. Idle mode
2. Single measurement mode
3. Continuous measurement mode (10Hz, 20Hz, 50Hz, 100Hz, 200Hz, 500Hz, 700Hz and 1.4kHz)
4. Self-test mode

Operating Mode	Start of Mode	End of Mode (Return to IDLE)	Measurement Data
Single measurement	Command to enter mode 1 or 9	Measurement finished	(T)XYZ
Continuous mode	Command to enter mode 2, 3, 4, 5, 10, 11, 12, 13	Transition to other mode	(T)XYZ
Idle Mode	Power up or command to enter mode 0, 7, 8, 15	Transition to other mode	-
Self-test Mode	Command to enter mode 6 and 14 from Idle	Measurement finished	Z

7.1.1. Single measurement mode

When the *Single measurement mode* is set, a magnetic measurement is started. After a measurement and when the signal processing is finished, the measurement data is stored to the data registers (**X**, **Y** and **Z**). After this, the sensor will go to the *Idle mode* automatically.

While going to the *Idle mode*, **MODE[3:0]** bits turns to 0. At the same time, **DRDY** bit (Data Ready) in **STAT1** register turns to Low.

When any of measurement data register (**X**, **Y** and **Z**) is read, **DRDY** bit turns to Low. It remains High when switching from *Idle mode* to another mode.

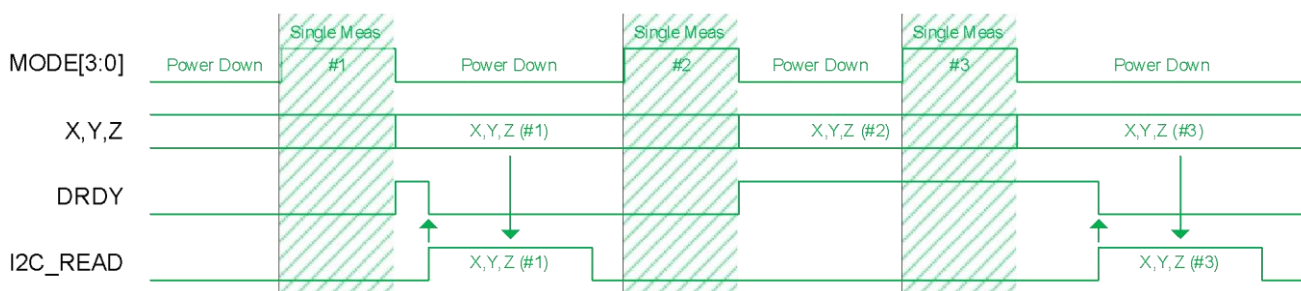

Figure 4: Single measurement mode when data is read out of measurement period

When the sensor is measuring, the data registers (X, Y and Z) keep the previous data. Therefore, it is possible to read out data even during measurement periods.

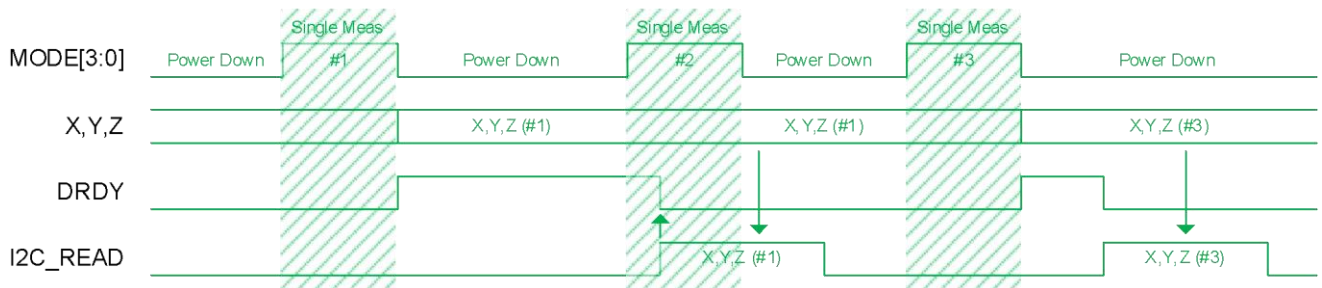

Figure 5: Single measurement mode when data read started during measurement period

7.1.2. Continuous measurement Mode

When the "Continuous measurement" mode is set, the measurement starts periodically. After measurement and signal processing is finished, the measurement data is stored to the data registers (**X**, **Y**, and **Z**). Almost all internal blocks are disabled ("Counting" power state).

After a measurement period, **the device** wakes up automatically from "Counting" power state and starts a new measurement.

The Continuous measurement mode ends when "Idle" mode (**MODE[3:0]** bits = 0) is set. If the measurement period is changed while **the device** is already configured in "Continuous measurement" mode, a new measurement starts.

STAT1 and measurement data registers (**X**, **Y** and **Z**) will not be initialized by this.

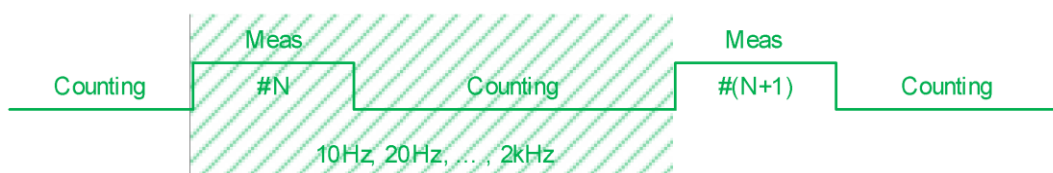

Figure 6: Continuous measurement mode

7.1.2.1. Data Ready

When the measurement data is stored and ready to be read, the **DRDY** bit (Data ready) in **STAT** register is set to High. When a measurement is performed correctly, the device sets the Data Ready bit before going back to "Counting" power state.

7.1.2.2. Normal Read Sequence

The stored measurement data is protected during the data reading. There is no update of the data during this time. Consequently, the following sequence should be followed:

1. **Check if the Data is Ready or not** by polling **DRDY** bit of **STAT1** register
 - a. **DRDY**: Data Ready. The Data is ready when set High.
2. Reading of the **STAT1** register will not trigger the protection.
3. **Read measurement data** - When **any of** the measurement data register (**X**, **Y**, or **Z**) is read, the device enables the protection as soon as the register is copied into the I2C sending register. When data reading starts, **DRDY (Data ready)** bit turns Low.
4. **Read STAT2 register (required for data consistency - provides information on overflow and data skip)**

When this read sequence is followed and there is no attempted I2C read during measurement, reading of **STAT2** sets the **DOR** bit to low (see I/O registers description for reference).

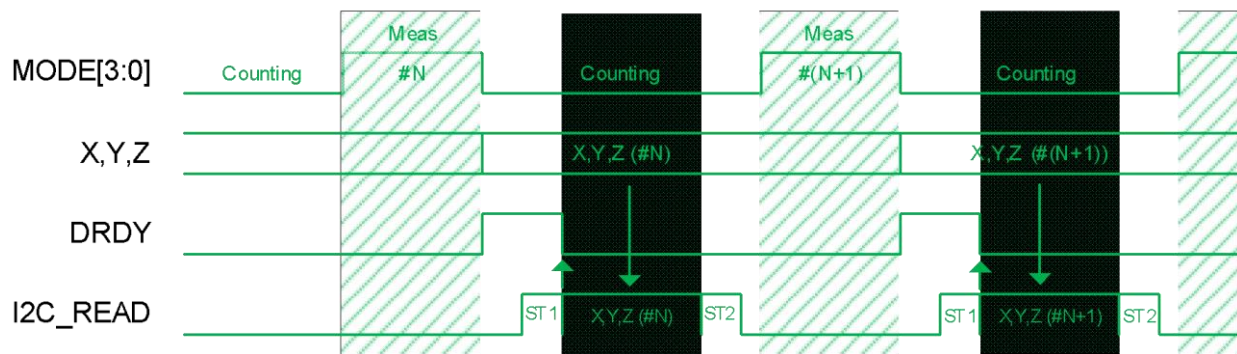

Figure 7: Normal read sequence

7.1.2.3. Data Read Start during Measurement

When the sensor is measuring, the measurement data registers (X, Y and Z) keep the previous data. Therefore, it is possible to read out data even in measurement period.

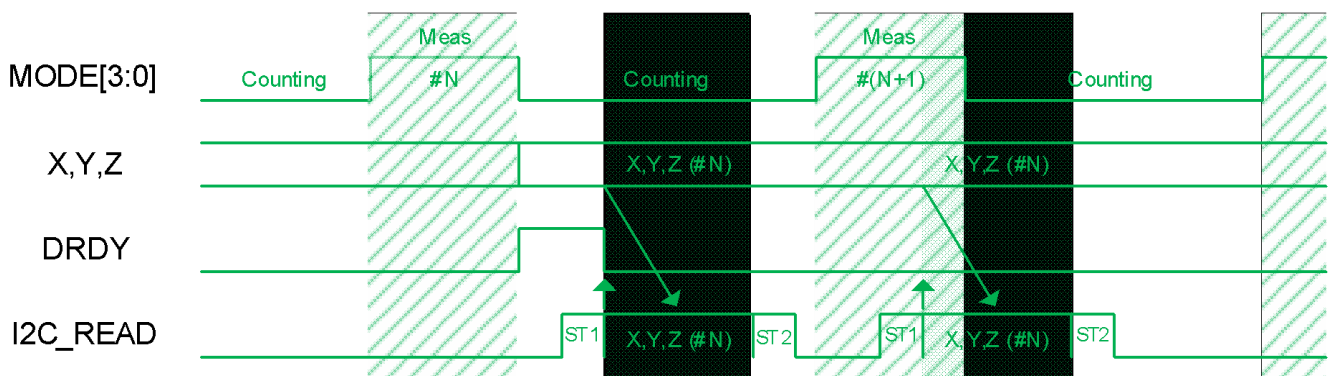

Figure 8: Data read start during measurement

7.1.2.4. Data Skip

If the available data is not read before a new measurement ends, the DRDY bit (Data Ready) remains High. However, a new set of measurement data will replace the previous one.

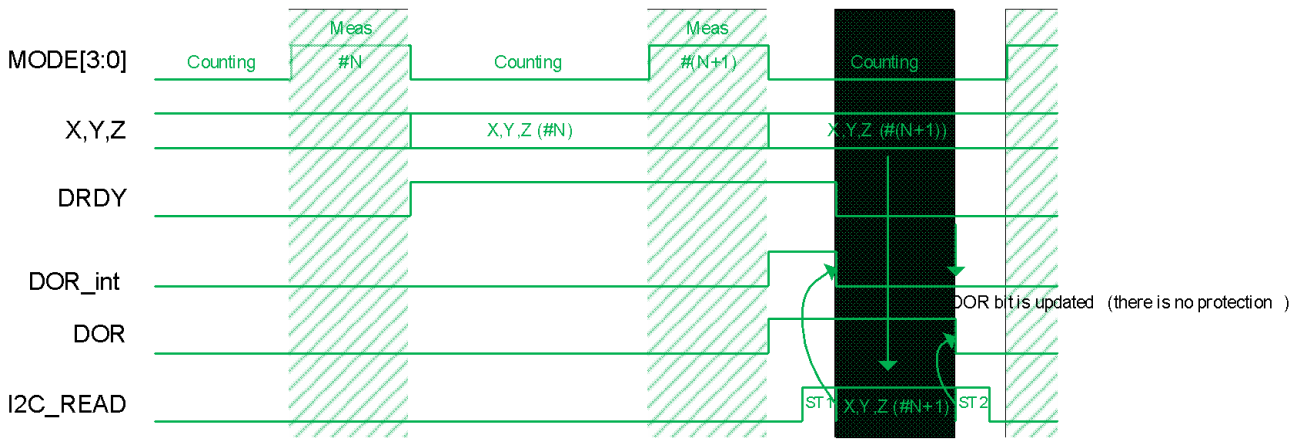

Figure 9: Data Skip: When data is not read

If the available data is read while a new measurement is being performed, this set of data will be protected. This is also the case even if the reading procedure finishes after the measurement. Consequently, this new set of data is skipped.

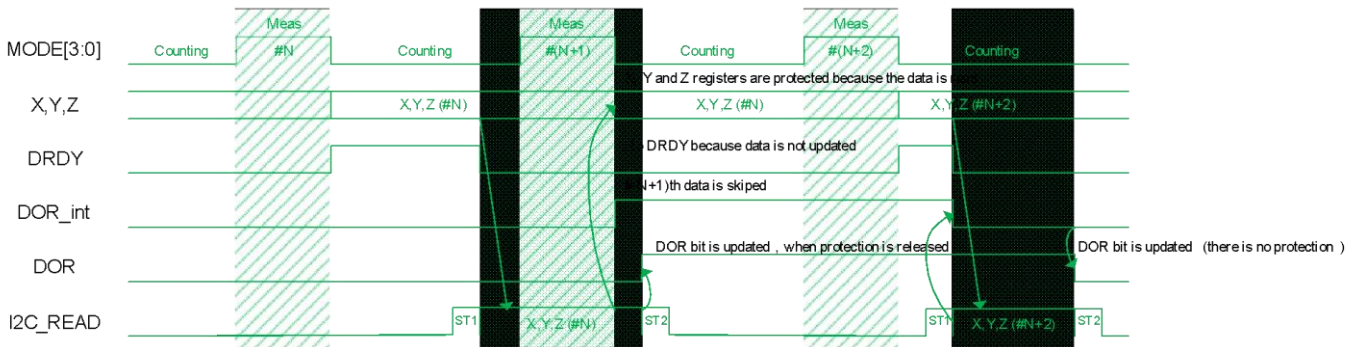

Figure 10: Data Skip: When data read has not been finished before the next measurement end

7.1.2.5. End Operation

Set the Idle mode (**MODE[3:0]** bits = 0) to end the Continuous measurement mode.

7.1.2.6. Magnetic Sensor Overflow

Version - 010

The sum of absolute values of each axis must be smaller than **4912μT** to avoid an overflow. (BRG: **0.15μT/LSB**)

$$|X|+|Y|+|Z| < 4912\mu\text{T}$$

2's complement	Hex	Dec	Magnetic flux density [μT]
0111_1111_1111_0000	7FF0	32752	4912
0000_0000_0000_0001	0001	1	0.15
0000_0000_0000_0000	0000	0	0
1111_1111_1111_1111	FFFF	-1	-0.15
1000_0000_0001_0000	8010	-32752	-4912

Table 12 - Measurement magnetic data format

Version - 011

The sum of absolute values of each axis must be smaller than **49.13mT** to avoid an overflow. (BRG: **1.5μT/LSB**)

$$|X|+|Y|+|Z| < 4913\mu\text{T}$$

2's complement	Hex	Dec	Magnetic flux density [μT]
0111_1111_1111_0000	7FF0	32752	4913
0000_0000_0000_0001	0001	1	1.5
0000_0000_0000_0000	0000	0	0
1111_1111_1111_1111	FFFF	-1	-1.5
1000_0000_0001_0000	8010	-32752	-4913

Table 13 - Measurement magnetic data format

The calculation is done as follows:

$$|X|+|Y|+|Z| < 32752$$

When the magnetic field exceeds this limitation, this is a Magnetic Sensor Overflow. When magnetic sensor overflow occurs, **HOVF** bit turns to “High”. The **HOVF** bit is updated as soon as the measurement data register (**X**, **Y** and **Z**) is updated.

7.1.3. Self-test Mode (recommended for version xxx - 010)

The Self-test mode is used to check if the magnetic sensor is working normally.

When the Self-test mode is set, a magnetic field is generated by the internal magnetic source and a measurement is performed. The data is stored to the data registers (**X**, **Y** and **Z**). The sensor will then go to Idle mode automatically. The correct sequence to set the Self-test Mode is described below:

7.1.3.1. Self-test Sequence

1. Set Idle mode.
2. Set Self-test mode.
3. Check Data Ready or not by polling **DRDY** bit (**Data Ready**) of **STAT1** register.
 - a. When the data is ready, proceed to the next step.
4. Read measurement data. (**X**, **Y** and **Z**)

7.1.3.2. *Self-test Judgment (used by the customer)*

The following criteria will help the user to decide if the sensor is correctly calibrated.

	DeltaX[15:0]	DeltaY[15:0]	DeltaZ[15:0]	Units
Criteria	$-150 \leq X \leq 150$	$-150 \leq Y \leq 150$	$-1200 \leq Z \leq -400$	LSB16

The typical magnetic field generated by the internal coil is around 135 μ T at room temperature. The self-test judgement are the expected values over temperature and voltage variations

7.1.4. Idle mode

In Idle mode, the device is in minimal power consumption state. All internal blocks including the oscillator are disabled except the POR circuit. Only the communication over the I2C interface is maintained. The digital handling of the communication is clocked by the I2C master clock. All registers remain accessible and the data stored in read/write registers remains.

7.2. Output protocol (I2C) description

7.2.1. Command implementation

The following I2C commands are implemented:

- **MEM_DIRECT_READ**: reads data from memory space, starting from the default address 0x00
- **MEM_READ**: the start address will be specified in the command and the address will be incremented for continuous reading until an I2C stop is detected.
- **MEM_WRITE**: the start address will be specified followed by the data to be stored at addresses starting from the given start address and incremented until an I2C stop is detected.
- **ADDRESSED_RESET**: reset of the device, based on the I2C Slave Address (reset of addressed devices on the I2C bus only)

In the next sections, the format of the different I2C commands is explained.
The following legend is used:

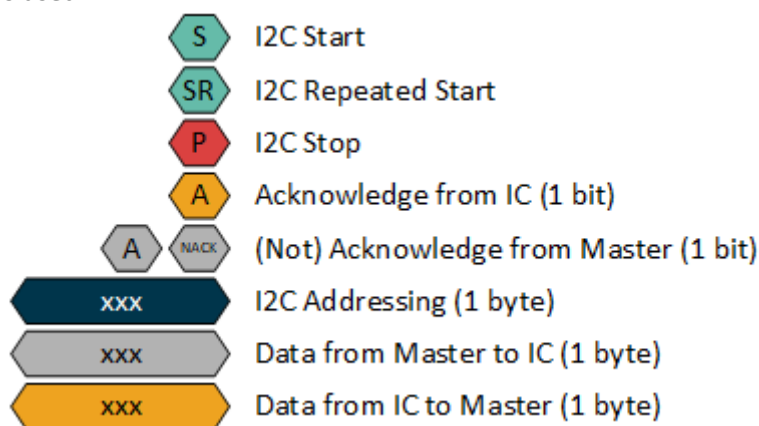

7.2.1.1. Read Commands

There are two read commands that are implemented

- **MEM_DIRECT_READ**: reads data from memory space, starting from the default address 0x00
- **MEM_READ**: the start address will be specified in the command and the address will be incremented for continuous reading until an I2C stop is detected.

7.2.1.1.1. MEM_DIRECT_READ (direct read) Command

MEM_DIRECT_READ: reads data from memory space, starting from the default address 0x00



Figure 11: I2C - MEM_DIRECT_READ (direct read) Command

NOTES:

- Incremental readout – return 0x00 when address out of valid space
- **NAK is needed from master** to allow going to STOP

7.2.1.1.2. MEM_READ (addressed read)

MEM_READ: the start address will be specified in the command and the address will be incremented for continuous reading until an I2C stop (P) is detected.

Incremental read-out starting at a given address (Register Start Address).

Normally it will read 1x register only, but the slave will continue to transmit data of sequential register addresses until the master terminates the communication.



Figure 11: I2C - MEM_READ (addressed read)

Important! A repeated START is required to perform an “addressed read”. Without repeated START, the command will be seen as a “direct read”.

As soon as incremental addressing leaves the address space, the slave will respond with all 0x00.

NOTES:

- Incremental readout – return 0x00 when address out of valid space
- **NAK is needed from master** to allow going to STOP

7.2.1.2. MEM_WRITE (addressed write) Command

MEM_WRITE: the start address will be specified followed by the data to be stored at addresses starting from the given start address and incremented until an I²C stop (P) is detected.

Incremental write starting at a given address (Register Start Address).

Normally you write 1x register only, but optionally the master can continue to transmit data of sequential register addresses to reduce the communication time when a lot of registers should be written.

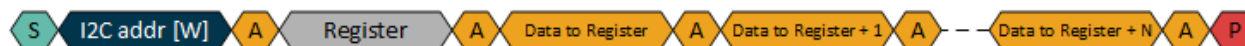

Figure 12: I2C - MEM_WRITE (addressed write) Command

The slave is sending AK/NAK based on the fact whether it was able to write data

The slave will automatically increment the address of the read out byte, independent if it gave an AK or a NAK to the master. It is up to the master to re-write the byte afterwards.

When the device is busy with the write operation, new write commands will be ignored. A read operation will return invalid data.

7.2.1.3. ADDRESSED_RESET: Addressed reset

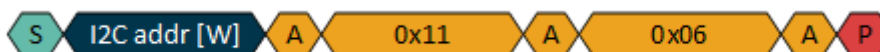

The addressed reset command brings the device back into a state like it was after power-on. The I2C Slave Address is used, which means that only the addressed devices on the I2C bus will be reset.

7.3. Memory items description

7.3.1. Memory Structure

The MLX90392 has registers (ports) of 16 addresses. Each address consists of 8 bits data. Data is transferred to or received from the external CPU via the I2C interface.

Address	Name	Description	R/W	7	6	5	4	3	2	1	0
0x00	STAT1	Status Register 1	R	-	-	-	-	RT	-	-	DRDY
0x01	X[7:0]	X-axis Measurement Magnetic Data [7:0]	R	-	-	-	-	-	-	-	-
0x02	X[15:8]	X-axis Measurement Magnetic Data [15:8]	R	-	-	-	-	-	-	-	-
0x03	Y[7:0]	Y-axis Measurement Magnetic Data [7:0]	R	-	-	-	-	-	-	-	-
0x04	Y[15:8]	Y-axis Measurement Magnetic Data [15:8]	R	-	-	-	-	-	-	-	-
0x05	Z[7:0]	Z-axis Measurement Magnetic Data [7:0]	R	-	-	-	-	-	-	-	-
0x06	Z[15:8]	Z-axis Measurement Magnetic Data [15:8]	R	-	-	-	-	-	-	-	-
0x07	STAT2	Status Register 2	R	-	-	-	-	-	-	DOR	HOVF
0x08	T[7:0]	Temperature Measurement Data Lower 8-bit	R	-	-	-	-	-	-	-	-
0x09	T[15:8]	Temperature Measurement Data Higher 8-bit	R	-	-	-	-	-	-	-	-
0x0A	CID	Company ID [7:0]	R	-	-	-	-	-	-	-	-
0x0B	DID	Device ID [7:0]	R	-	-	-	-	-	-	-	-
0x0C		Not used		-	-	-	-	-	-	-	-
0x0D		Not used		-	-	-	-	-	-	-	-
0x0E		Not used		-	-	-	-	-	-	-	-
0x0F		Not used		-	-	-	-	-	-	-	-
0x10	CTRL	Control Register (Application Mode)	R/W	-	-	-	-	MODE[3:0]			
0x11	RST	Reset = 0x06	R/W	-	-	-	-	-	-	-	-
0x12		Not used		-	-	-	-	-	-	-	-
0x13		Not used		-	-	-	-	-	-	-	-
0x14	OSR_DIG_FILT	OSR_DIG_FILT[7:0]	R/W	OSR_HALL	OSR_TEMP	DIG_FILT_HALL_XY[2:0]			DIG_FILT_TEMP[2:0]		
0x15	T_EN_DIG_FILT_Z	CUST_CTR	R/W	DNC=1	DNC=0	T_COMP_EN	DNC=1	-	DIG_FILT_HALL_Z[2:0]		

Table 14 – Memory map

DNC=Do Not Change

The **STAT1** register is mapped on address **0x00**, since it is the default address of **MEM_DIRECT_READ** (direct read) command.

The idea is that first the user has to read the status bits **DRDY** to check if there is new data and if there is new data, to continue the command to read the registers **X**, **Y** and **Z**.

7.3.2. I/O registers description

1. Address 0x00. STAT1[7:0]

7	6	5	4	3	2	1	0
STAT1_7	STAT1_6	STAT1_5	STAT1_4	RT	STAT1_2	STAT1_1	DRDY
RW-0	RW-0	RW-0	RW-0	RW-1	RW-0	RW-0	RW-0

NOTE: R=Read access; W=Write access; value following dash (-) = value after reset

Bit 7 – 4 STAT1[7:4]. Reserved (Not used)

- RT. The device is reset
- Bit 3 0 – The device was not reset
 1 – The device was reset and this is the first reading. Automatically set to 0 when the first reading of STAT register is done
- Bit 2 – 1 STAT1[2:1]. Reserved (Not used)
- DRDY. Data Ready.
DRDY bit turns to “1” when data is ready in "Single measurement" mode, "Continuous measurement" mode or "Self-test" mode.
It returns to “0” when any one the measurement data register (X, Y or Z) is read
- Bit 0 0 – Normal
 1 – Data is ReaDY

2. Addresses 0x01- 0x06. XYZ[15:0]

- Bit 7 – 0 X[7:0]. LSB byte of X axis
Bit 15 – 8 X[15:8]. MSB byte of X axis
Bit 7 – 0 Y[7:0]. LSB byte of Y axis
Bit 15 – 8 Y[15:8]. MSB byte of Y axis
Bit 7 – 0 Z[7:0]. LSB byte of Z axis
Bit 15 – 8 Z[15:8]. MSB byte of Z axis

3. Address 0x07. STAT2[7:0]

7	6	5	4	3	2	1	0
STAT2_7	STAT2_6	STAT2_5	STAT2_4	STAT2_3	STAT2_2	DOR	HOVF
RW-0	RW-0	RW-0	RW-0	RW-0	RW-0	RW-0	RW-0

NOTE: R=Read access; W=Write access; value following dash (-) = value after reset

STAT2 register contains the following bits:

- Bit 7 – 2 **STAT2[7:2].** Reserved (Not used)
- DOR.** Data Overrun
DOR bit turns to “1” when data has been skipped in "Continuous measurement" mode. It returns to “0” when the data registers (X, Y, Z) are read.
- Bit 1 0 – Normal
 1 – Data OverRun

HOVF. Magnetic Sensor OverFlow
 Bit 0 0 – Normal
 1 – Magnetic Sensor Overflow occurred

In "Single measurement" mode, "Continuous measurement" mode and "Self-test" mode, the magnetic sensor may overflow even though the measurement data register is not saturated. In this case, measurement data is not correct and HOVF bit turns to "1". When the measurement data register is updated, HOVF bit is updated.

4. Addresses 0x08- 0x09. T[15:0]

Bit 7 – 0 T[7:0]. LSB byte of Temperature
 Bit 15 – 8 T[15:8]. MSB byte of Temperature

5. Addresses 0x0A. CID[7:0]

Bit 7 – 0 CID[7:0]. Company ID

6. Addresses 0x0B. DID[7:0]

Bit 7 – 0 DID[7:0]. Device ID

7. Addresses 0x10. CTRL[7:0]

7	6	5	4	3	2	1	0
CTRL_7	CTRL_6	CTRL_5	CTRL_4	MODE3	MODE2	MODE1	MODE0
RW-0	RW-0	RW-0	RW-0	RW-0	RW-0	RW-0	RW-0

NOTE: R=Read access; W=Write access; value following dash (-) = value after reset

Bit 7 - 4 **CTRL[7:4].** Reserved (Not used)

MODE[3:0]. Application Mode
 0 – Idle mode
 1 – Single Measurements mode
 2 – Continuous measurement mode 10Hz
 3 – Continuous measurement mode 20Hz
 4 – Continuous measurement mode 50Hz
 5 – Continuous measurement mode 100Hz
 6 – Self-test mode
 7 – Idle mode

- 8 – Idle mode
- 9 – Single Measurements mode
- 10 – Continuous measurement mode 200Hz
- 11 – Continuous measurement mode 500Hz
- 12 – Continuous measurement mode 800Hz
- 13 – Continuous measurement mode 1.4kHz
- 14 – Self-test mode
- 15 – Power-down mode

8. Addresses 0x11. RST[7:0]

Bit 7 – 0 RST[7:0]. Addressed RESET when users sends an I2C_ADDRESSED_RESET command

9. Addresses 0x12-0x13. Not used

10. Addresses 0x14. OSR_DIG_FILT[7:0]

7	6	5	4	3	2	1	0
OSR_HALL	OSR_TEMP	DIG_FILT_HALL_XY2	DIG_FILT_HALL_XY1	DIG_FILT_HALL_XY0	DIG_FILT_TEMP_MP2	DIG_FILT_TEMP_MP1	DIG_FILT_TEMP_MP0
RW-0	RW-0	RW-0	RW-0	RW-0	RW-0	RW-0	RW-0

NOTE: R=Read access; W=Write access; value following dash (-) = value after reset

OSR_HALL. Over Sampling Ratio setting for the magnetic measurements

Bit 7
0 - 32
1 - 64

OSR_TEMP. Over Sampling Ratio setting for the temperature measurement

Bit 6
0 - 32
1 - 64

DIG_FILT_HALL_XY[2:0]. DIG_FILT setting for X and Y magnetic measurements

Bits 5 - 3
0 - 0.113ms @ OSR = 0; 0.220ms @ OSR = 1
1 - 0.167ms @ OSR = 0; 0.327ms @ OSR = 1
2 - 0.273ms @ OSR = 0; 0.540ms @ OSR = 1
3 - 0.487ms @ OSR = 0; 0.967ms @ OSR = 1
4 - 0.913ms @ OSR = 0; 1.820ms @ OSR = 1
5 - 1.767ms @ OSR = 0; 3.527ms @ OSR = 1
6 - 3.473ms @ OSR = 0; 6.940ms @ OSR = 1
7 - 6.887ms @ OSR = 0; 13.767ms @ OSR = 1

DIG_FILT_TEMP[2:0]. DIG_FILT setting for the temperature measurements

Bits 2 - 0
0 - 0.113ms @ OSR = 0; 0.220ms @ OSR = 1
1 - 0.167ms @ OSR = 0; 0.327ms @ OSR = 1

- 2 - 0.273ms @ OSR = 0; 0.540ms @ OSR = 1
- 3 - 0.487ms @ OSR = 0; 0.967ms @ OSR = 1
- 4 - 0.913ms @ OSR = 0; 1.820ms @ OSR = 1
- 5 - 1.767ms @ OSR = 0; 3.527ms @ OSR = 1
- 6 - 3.473ms @ OSR = 0; 6.940ms @ OSR = 1
- 7 - 6.887ms @ OSR = 0; 13.767ms @ OSR = 1

11. Addresses 0x15. CUST_CTRL[7:0]

7	6	5	4	3	2	1	0
DNC = 1	DNC = 0	T_COMP_EN	DNC = 1	CUST_CTRL3	DIG_FILT_HALL_Z2	DIG_FILT_HALL_Z1	DIG_FILT_HALL_Z0
RW-0	RW-0	RW-0	RW-0	RW-0	RW-0	RW-0	RW-0

NOTE: R=Read access; W=Write access; value following dash (-) = value after reset

Bit 7 DNC=1. Value is preloaded from OTP with 0b1. Do not change it

Bit 6 DNC=0. Value is preloaded from OTP with 0b0. Do not change it

Bit 5 T_COMP_EN. Enable or disable the temperature measurement and compensation
0 - Disabled
1 - Enabled

Bit 4 DNC=1. Value is preloaded from OTP with 0b1. Do not change it

Bit 3 CUST_CTRL3.Reserved. Not used

Bit 2 - 0 DIG_FILT_HALL_Z[2:0]. DIG_FILT setting for Z magnetic measurements
0 - 0.113ms @ OSR = 0; 0.220ms @ OSR = 1
1 - 0.167ms @ OSR = 0; 0.327ms @ OSR = 1
2 - 0.273ms @ OSR = 0; 0.540ms @ OSR = 1
3 - 0.487ms @ OSR = 0; 0.967ms @ OSR = 1
4 - 0.913ms @ OSR = 0; 1.820ms @ OSR = 1
5 - 1.767ms @ OSR = 0; 3.527ms @ OSR = 1
6 - 3.473ms @ OSR = 0; 6.940ms @ OSR = 1
7 - 6.887ms @ OSR = 0; 13.767ms @ OSR = 1

7.4. Flowchart

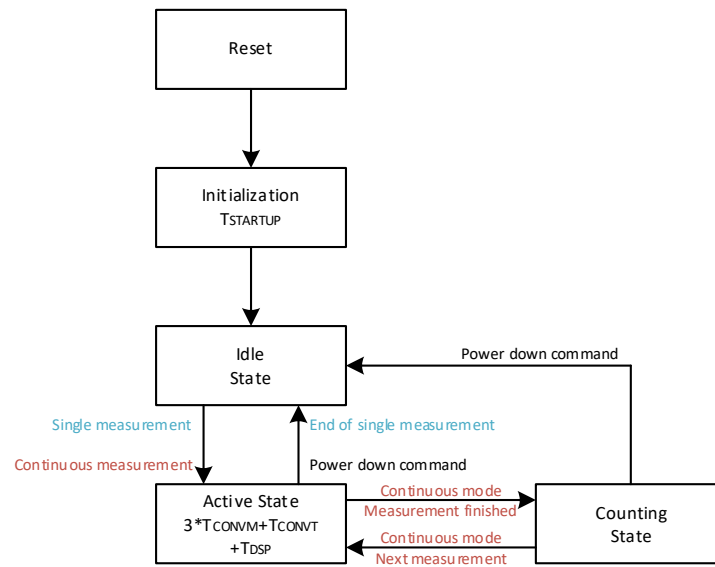

Figure 13: Sequence flowchart

7.5. Performance Graphs

7.5.1. Noise performance

7.5.1.1.1. Version 010 - Without temperature compensation

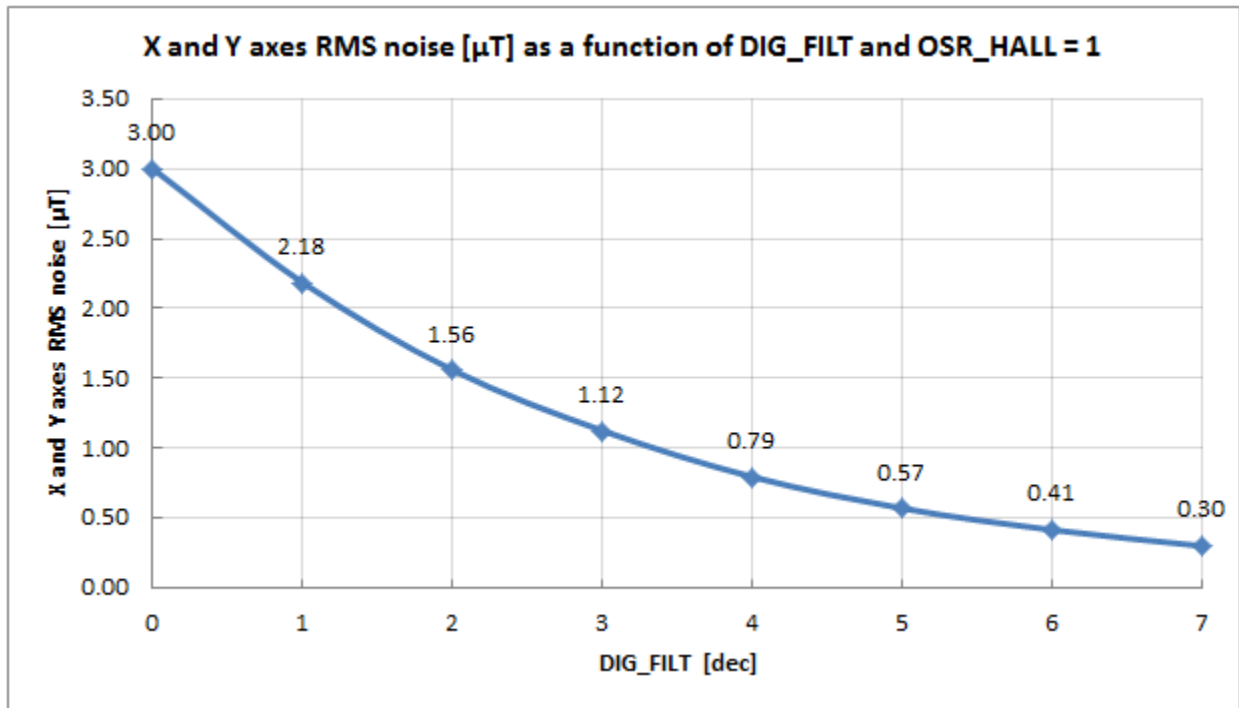

Figure 14: version 010 - XY axis RMS noise (typ)

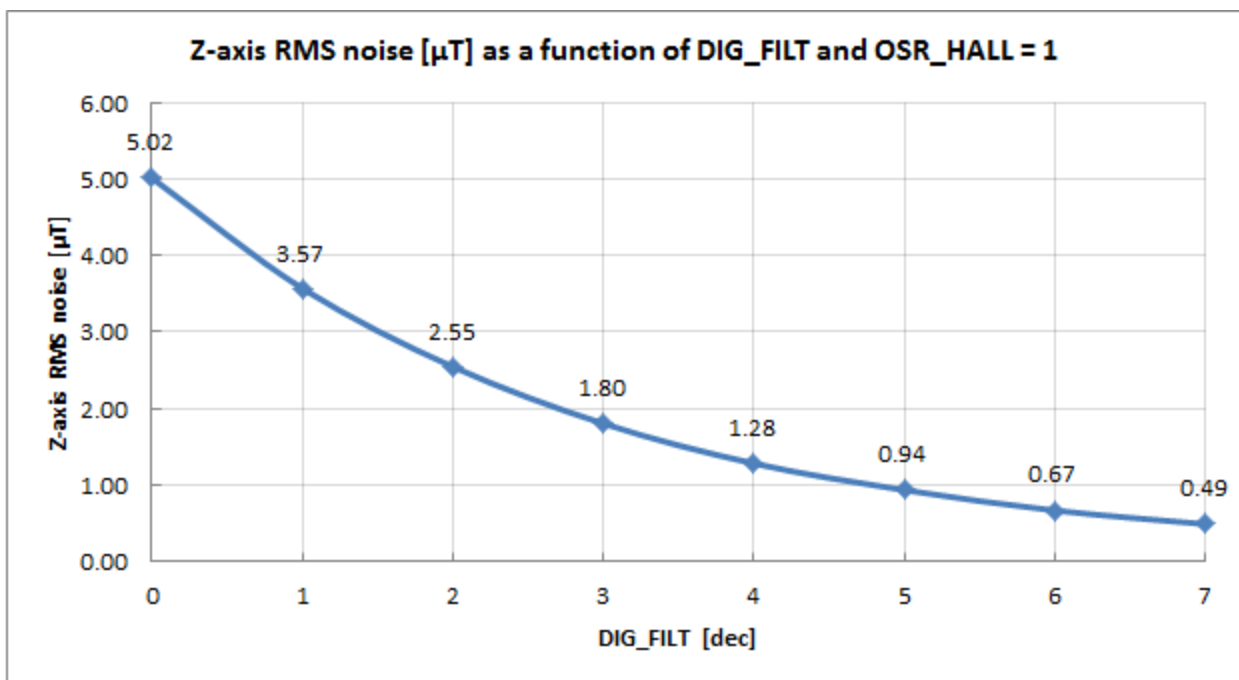

Figure 15: version 010 - Z axis RMS Noise (typ)

Note: When OSR_HALL is set to 0, the above values have to be scaled by $\sqrt{2}$.

7.5.1.1.2. With temperature compensation and maximum field

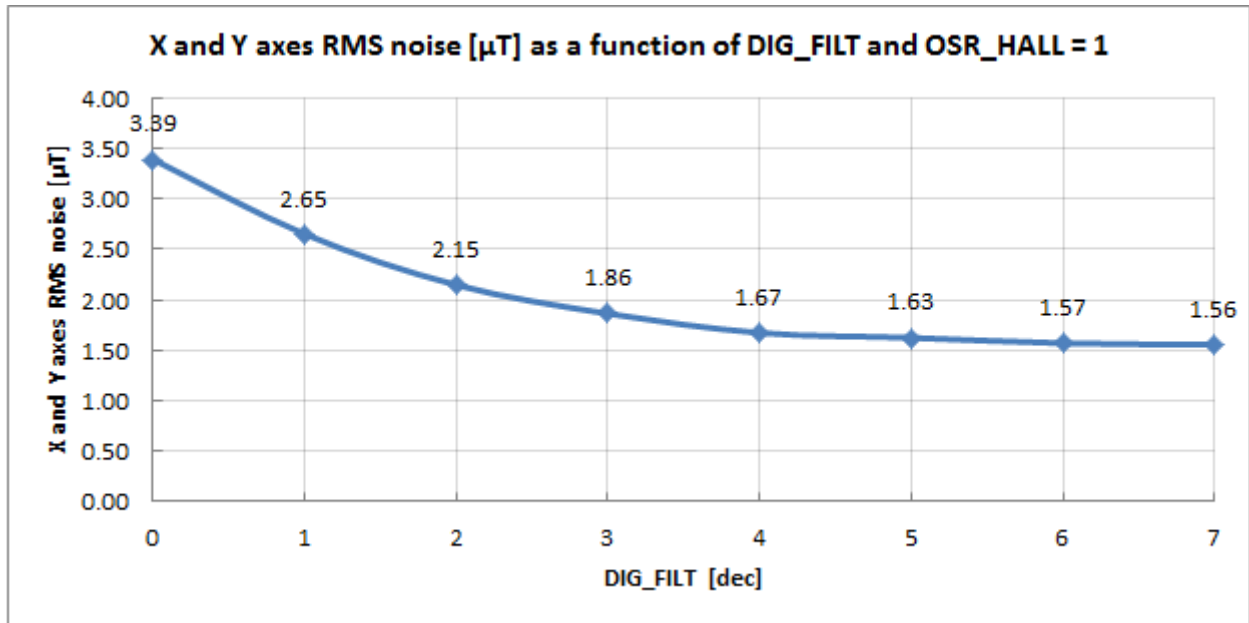

Figure 16: version 010 - XY axes RMS noise (typ)

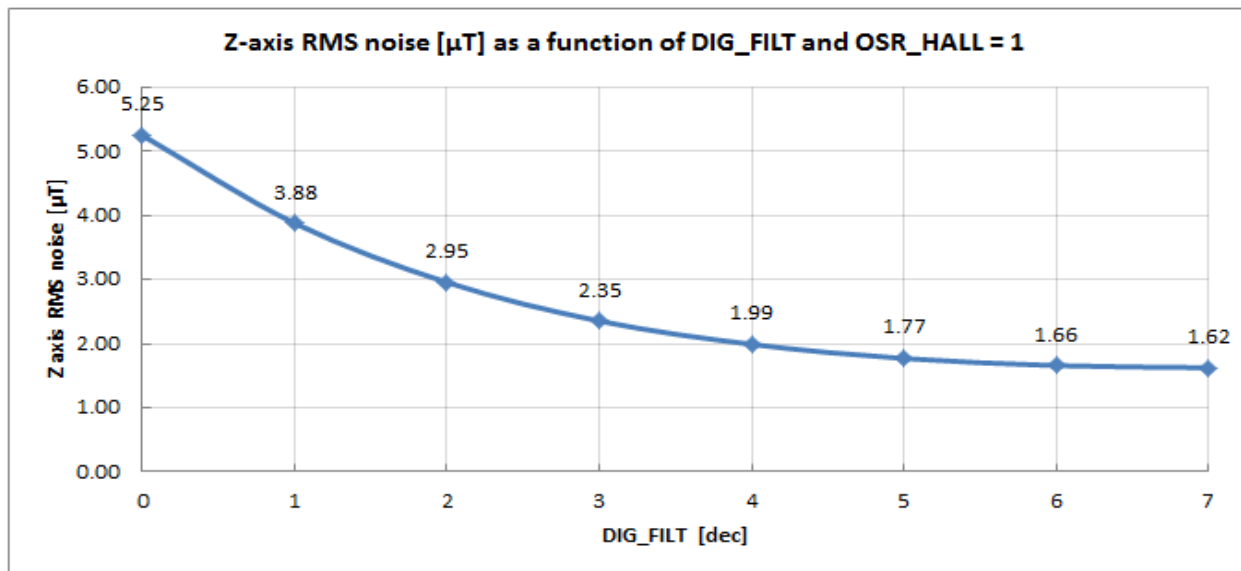

Figure 17: version 010 - Z axis RMS noise (typ)

7.5.1.1.3. Version 011 - Without temperature compensation

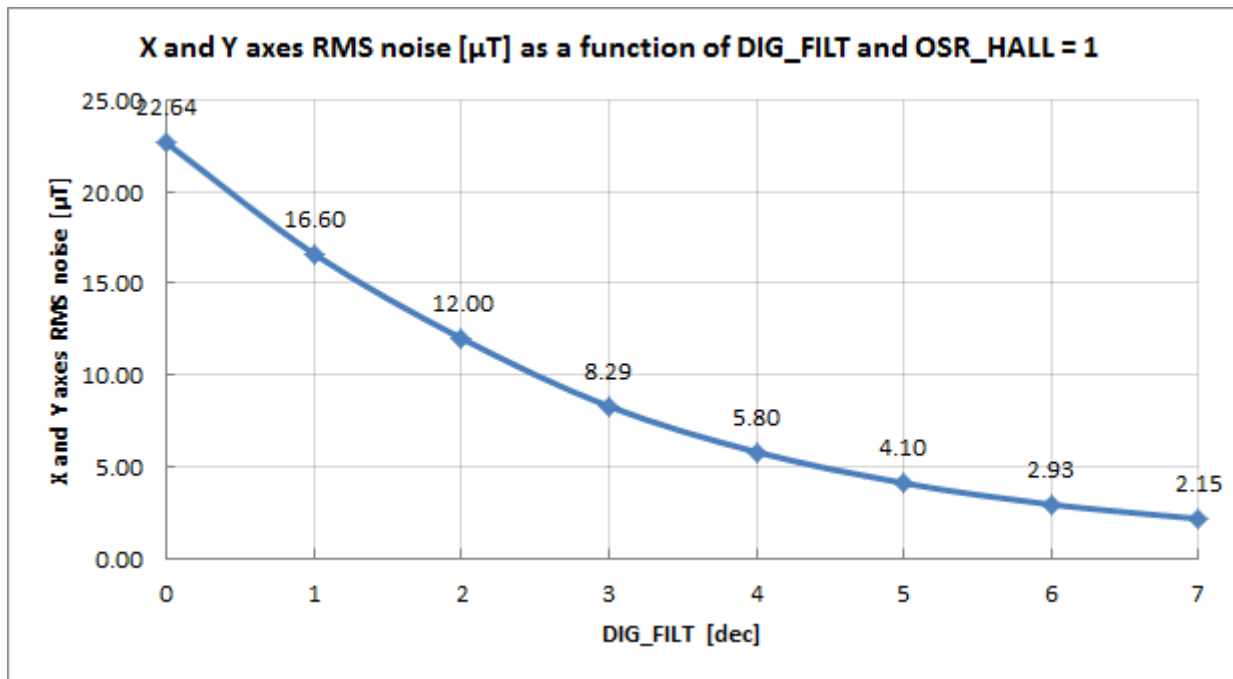

Figure 18: version 011 – XY axis RMS noise (typ)

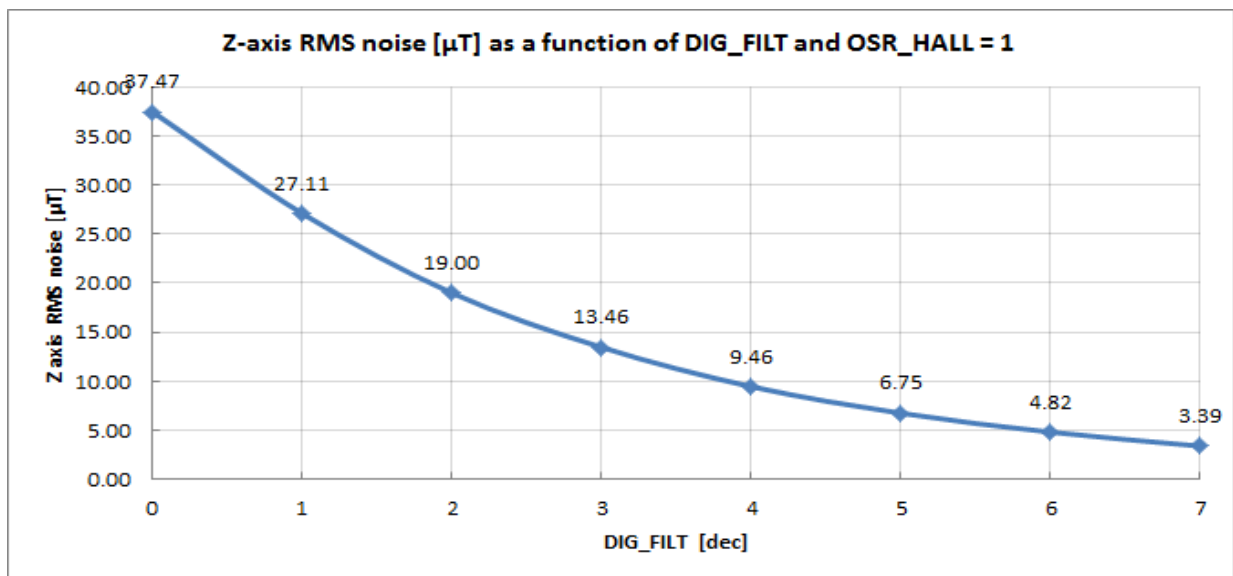

Figure 19: version 011 - Z axis RMS noise (typ)

7.5.1.1.4. With temperature compensation and maximum field

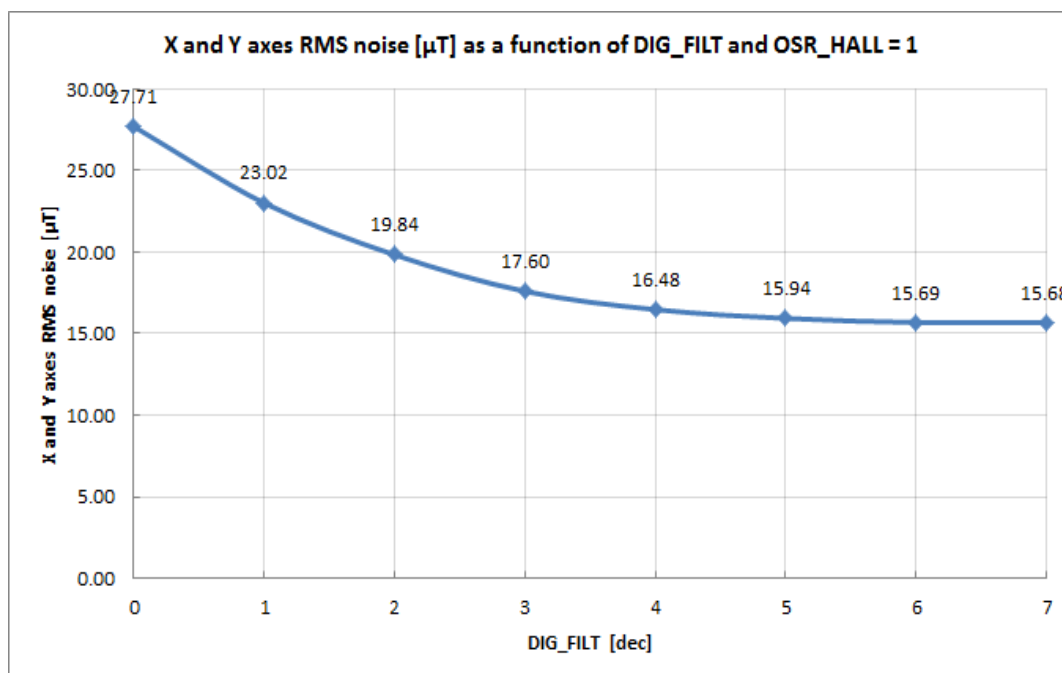

Figure 20: version 011 - XY axis RMS noise (typ)

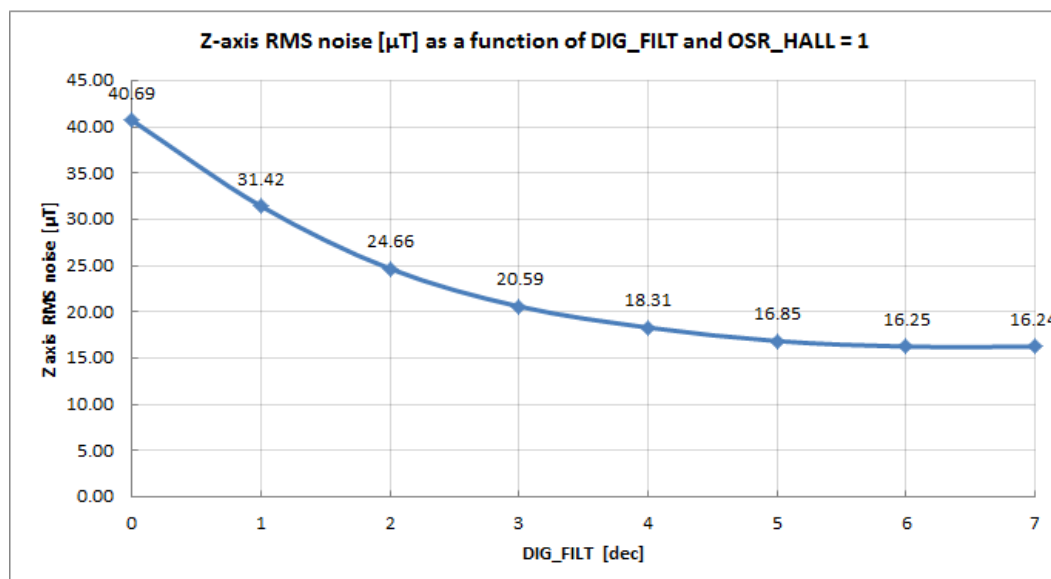

Figure 21: version 011 - Z axis RMS noise (typ)

7.6. Temperature compensation

The MLX90392 has a built-in temperature compensation, which is done by a piecewise linear approximation of the temperature coefficient of the Hall plates. A reference temperature is chosen ($T_{REF}=35^{\circ}C$), where the result at any temperature, higher than T_{REF} is adjusted by a gain $SENT_TC_HT$ and if the temperature is lower than T_{REF} - by $SENS_TC_LT$. These two coefficients are calibrated at Melexis and are lumped into the parameter name $SENS_TC$ in the equation below.

$$XYZ_{18_0} = XYZ_RAW_{18_0} \cdot \left[1 + \frac{SENS_TC_{11_0} \cdot (TEMP_{15_0} - TREF_{15_0})}{2^{SENS_TC_N_{3_0} + 18}} \right]$$

SENS_TC_N is a scaling factor needed for the fixed-point calculations. It is determined and written at Melexis during production test.

In case the temperature compensation is not needed, bit 5 in T_EN_DIG_FILT_Z register is set to 0. This also disables the temperature measurement and the term in the square brackets of the formula above is equal to 1.

The operation is executed on the 19 bits raw magnetic data which is consequently truncated to 16 bit and loaded into the results registers.

8. Application Information

8.1. Recommended Application Diagram

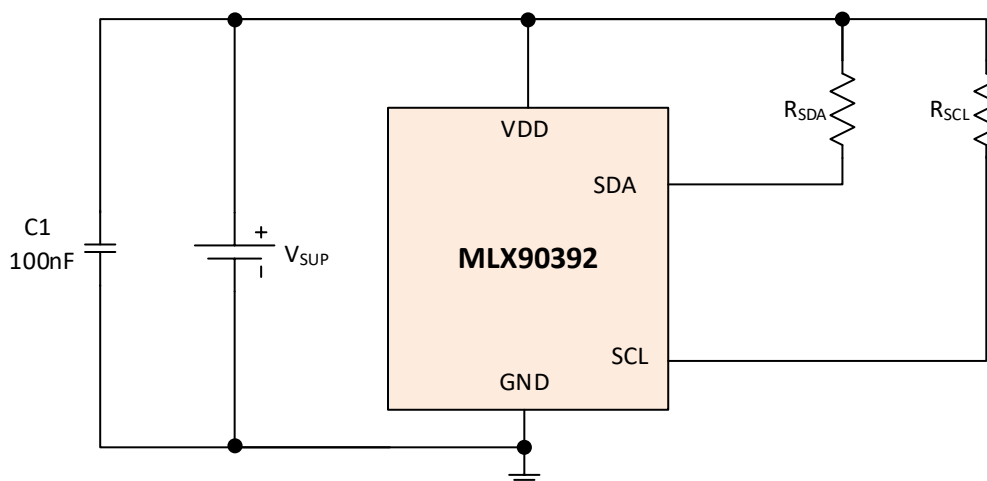

Figure 22: Recommended application diagram

Note: R_{SDA} and R_{SCL} are part of the bus specifications. Please refer to it.

9. Package and Manufacturability information

9.1. ESD precaution

Electronic semiconductor products are sensitive to Electro Static Discharge (ESD). Always observe Electro Static Discharge control procedures whenever handling semiconductor products.

9.2. Package information

9.2.1. Dimensions

UTDFN 2x2.5mm

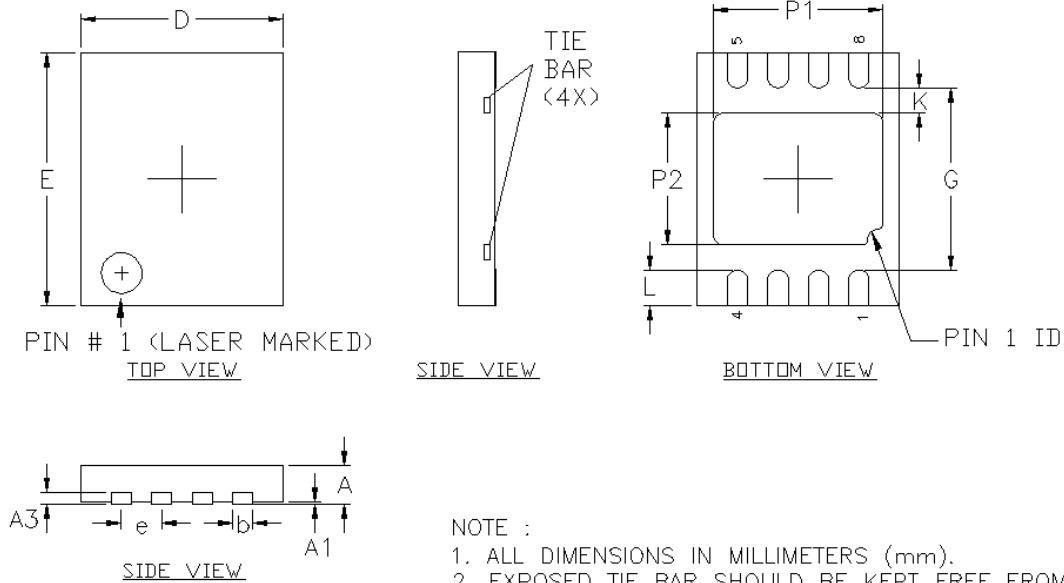

SYMBOL	MINIMUM	MAXIMUM
A	0.31	0.40
A1	0.00	0.05
A3	0.12 REF	
D	1.90	2.10
E	2.40	2.60
P1	1.45	1.70
P2	1.25	1.35
G	1.75	1.85
L	0.25	0.45
K	0.20	---
b	0.16	0.24
e	0.40 BSC	

9.2.2. Sensing element placement

Magnetic sweet spot

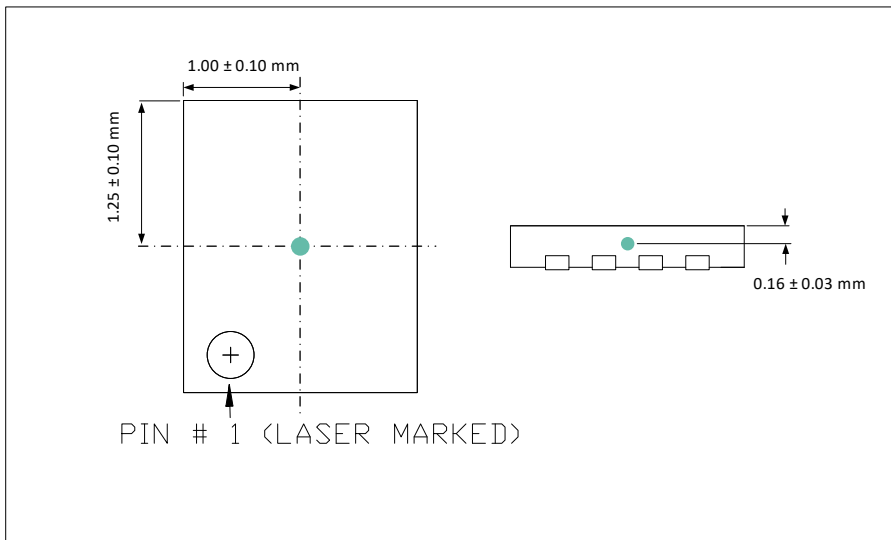
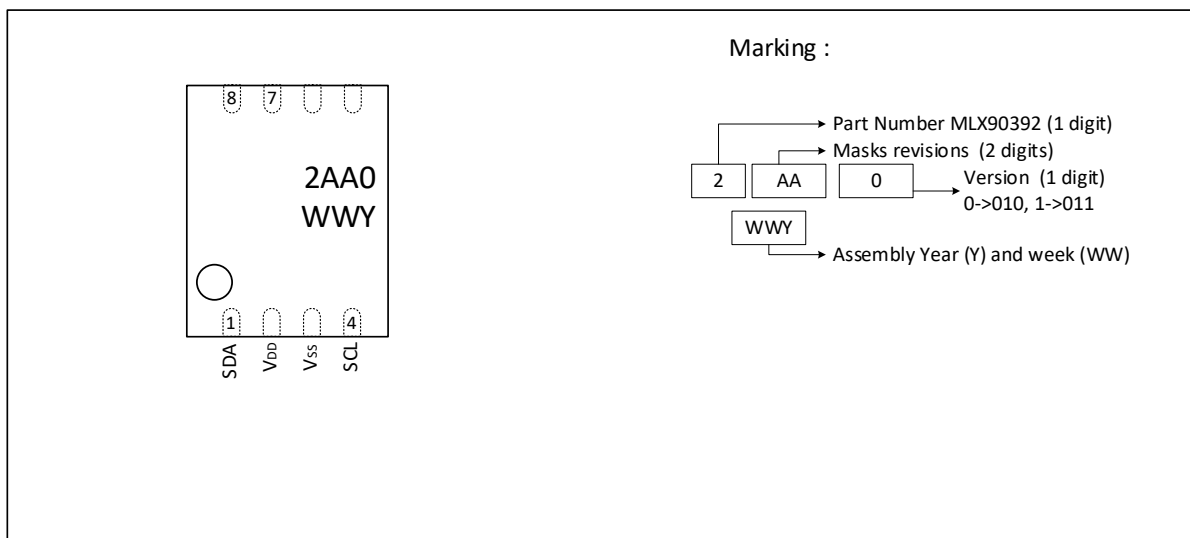

Figure 23: Field convention (Top view of the package with pin 1 at the bottom left)

9.2.3. Marking



9.3. Standard information on soldering processes

Our products are classified and qualified regarding soldering technology, solderability and moisture sensitivity level according to standards in place in Semiconductor industry.

For further details about test method references and for compliance verification of selected soldering method for product integration, Melexis recommends reviewing on our web site the General Guidelines soldering recommendation (<http://www.melexis.com/en/quality-environment/soldering>)

For all soldering technologies deviating from the one mentioned in above document (regarding peak temperature, temperature gradient, temperature profile etc.), additional classification and qualification tests have to be agreed upon with Melexis.

For package technology embedding trim and form post-delivery capability, Melexis recommends consulting the dedicated trim&form recommendation application note: lead trimming and forming recommendations (<http://www.melexis.com/en/documents/documentation/application-notes/lead-trimming-and-forming-recommendations>).

Melexis is contributing to global environmental conservation by promoting lead free solutions. For more information on qualifications of RoHS compliant products (RoHS = European directive on the Restriction Of the use of certain Hazardous Substances) please visit the quality page on our website:

<http://www.melexis.com/en/quality-environment>.

10. References

10.1. List of figures

Figure 1: IC block diagram	6
Figure 2: I ² C Timing Diagram	8
Figure 3: Conversion time	13
Figure 4: Single measurement mode when data is read out of measurement period	15
Figure 5: Single measurement mode when data read started during measurement period	16
Figure 6: Continuous measurement mode	17
Figure 7: Normal read sequence	18
Figure 8: Data read start during measurement.....	18
Figure 9: Data Skip: When data is not read	19
Figure 10: Data Skip: When data read has not been finished before the next measurement end	19
Figure 11: I2C - MEM_DIRECT_READ (direct read) Command	23
Figure 12: I2C - MEM_WRITE (addressed write) Command	23
Figure 13: Sequence flowchart	29
Figure 14: version 010 - XY axis RMS noise (typ)	30
Figure 15: version 010 - Z axis RMS Noise (typ).....	30
Figure 16: version 010 - XY axes RMS noise(typ)	31
Figure 17: version 010 - Z axis RMS noise (typ)	31
Figure 18: version 011 – XY axis RMS noise (typ)	32
Figure 19: version 011 - Z axis RMS noise (typ)	32
Figure 20: version 011 - XY axis RMS noise (typ)	33
Figure 21: version 011 - Z axis RMS noise (typ)	33
Figure 22: Recommended application diagram	34
Figure 23: Field convention (Top view of the package with pin 1 at the bottom left).....	36

10.2. List of tables

Table 1 – Ordering codes	2
Table 2 – Pin description.....	6
Table 3– Absolute Maximum Ratings.....	7
Table 4 – General operating conditions.....	7
Table 5 – Electrical Operating conditions	7
Table 6 – Magnetic Operating conditions	7
Table 7: General I ² C Timing Specification	8
Table 8 – Electrical Operating conditions	10
Table 9 – Magnetic Specifications	11
Table 10 – Timing specifications.....	12
Table 11 – Accuracy specifications	14
Table 12 - Measurement magnetic data format	20
Table 13 - Measurement magnetic data format	20
Table 14 – Memory map.....	24

11. Revision History

Revision	Date	Change history
001	13-Jan-2021	First datasheet issue (JED)
002	15-Apr-2021	Revised specifications. Package dimensions updated + Cosmetic changes (JED)

12. Disclaimer

The content of this document is believed to be correct and accurate. However, the content of this document is furnished "as is" for informational use only and no representation, nor warranty is provided by Melexis about its accuracy, nor about the results of its implementation. Melexis assumes no responsibility or liability for any errors or inaccuracies that may appear in this document. Customer will follow the practices contained in this document under its sole responsibility. This documentation is in fact provided without warranty, term, or condition of any kind, either implied or expressed, including but not limited to warranties of merchantability, satisfactory quality, non-infringement, and fitness for purpose. Melexis, its employees and agents and its affiliates' and their employees and agents will not be responsible for any loss, however arising, from the use of, or reliance on this document. Notwithstanding the foregoing, contractual obligations expressly undertaken in writing by Melexis prevail over this disclaimer.

This document is subject to change without notice, and should not be construed as a commitment by Melexis. Therefore, before placing orders or prior to designing the product into a system, users or any third party should obtain the latest version of the relevant information.

Users or any third party must determine the suitability of the product described in this document for its application, including the level of reliability required and determine whether it is fit for a particular purpose.

This document as well as the product here described may be subject to export control regulations. Be aware that export might require a prior authorization from competent authorities. The product is not designed, authorized or warranted to be suitable in applications requiring extended temperature range and/or unusual environmental requirements. High reliability applications, such as medical life-support or life-sustaining equipment or avionics application are specifically excluded by Melexis. The product may not be used for the following applications subject to export control regulations: the development, production, processing, operation, maintenance, storage, recognition or proliferation of:

- 1. chemical, biological or nuclear weapons, or for the development, production, maintenance or storage of missiles for such weapons;*
- 2. civil firearms, including spare parts or ammunition for such arms;*
- 3. defense related products, or other material for military use or for law enforcement;*
- 4. any applications that, alone or in combination with other goods, substances or organisms could cause serious harm to persons or goods and that can be used as a means of violence in an armed conflict or any similar violent situation.*

No license nor any other right or interest is granted to any of Melexis' or third party's intellectual property rights.

If this document is marked "restricted" or with similar words, or if in any case the content of this document is to be reasonably understood as being confidential, the recipient of this document shall not communicate, nor disclose to any third party, any part of the document without Melexis' express written consent. The recipient shall take all necessary measures to apply and preserve the confidential character of the document. In particular, the recipient shall (i) hold document in confidence with at least the same degree of care by which it maintains the confidentiality of its own proprietary and confidential information, but no less than reasonable care; (ii) restrict the disclosure of the document solely to its employees for the purpose for which this document was received, on a strictly need to know basis and providing that such persons to whom the document is disclosed are bound by confidentiality terms substantially similar to those in this disclaimer; (iii) use the document only in connection with the purpose for which this document was received, and reproduce document only to the extent necessary for such purposes; (iv) not use the document for commercial purposes or to the detriment of Melexis or its customers. The confidentiality obligations set forth in this disclaimer will have indefinite duration and in any case they will be effective for no less than 10 years from the receipt of this document.

This disclaimer will be governed by and construed in accordance with Belgian law and any disputes relating to this disclaimer will be subject to the exclusive jurisdiction of the courts of Brussels, Belgium.

The invalidity or ineffectiveness of any of the provisions of this disclaimer does not affect the validity or effectiveness of the other provisions.

The previous versions of this document are repealed.

Melexis © - No part of this document may be reproduced without the prior written consent of Melexis. (2021)

IATF 16949 and ISO 14001 Certified

For the latest version of this document, visit
www.melexis.com

Mouser Electronics

Authorized Distributor

Click to View Pricing, Inventory, Delivery & Lifecycle Information:

[Melexis:](#)

[MLX90392ELQ-AAA-010-RE](#) [MLX90392ELQ-AAA-010-SP](#) [MLX90392ELQ-AAA-011-RE](#) [MLX90392ELQ-AAA-011-SP](#)