

1. Scope

This document is applied to the magnetic sensor for detecting a rotating magnet.

2. Part number

2-1 Part Description                      Magnetic Sensor  
 2-2 Murata Part Number                MRMS791B

3. Dimensions and Schematics

3-1 Dimensions

3-1-1 Package outline drawing        (Unit :mm)

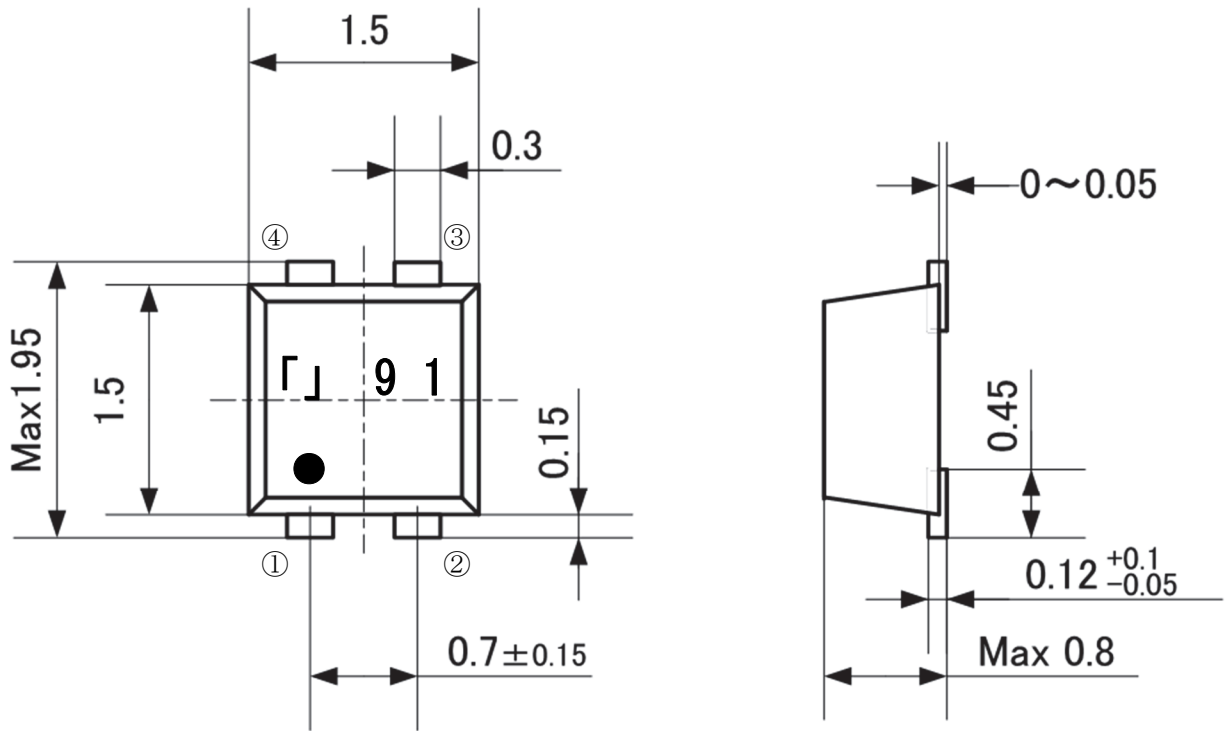

① : GND    ② : Enable    ③ : NC    ④ : OUT

3-1-2 Marking example

(E.g.) 「」 91    I    Control code...One alphabetic character  
          ↓↓↓    II    Manufactured year...The last digit of the year  
          I II III   III    Manufactured month..  
                                  Jan to Sep : 1 to 9  
                                  Oct to Dec : X, Y, Z

3-1-3 Reference mount pad (Unit:mm)

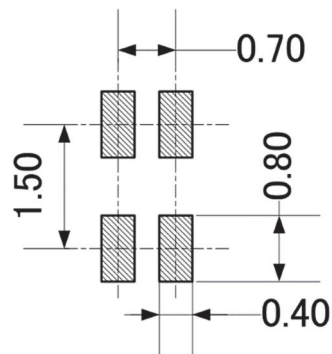

NOTE1) Please evaluate your soldering paset condition and reflow condition with our product being mounted to your product.

NOTE2) Please make sure the sensing direction of the sensor (see the item 3-2) and your magnetic field direction to the sensor.

3-2 Magnetic field application direction

ON / OFF is switched by rotating the magnetic field.

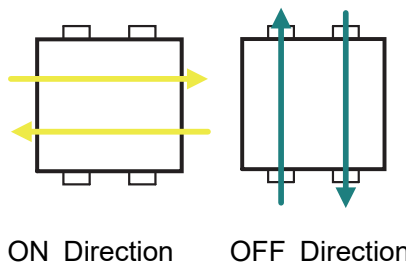

3-3 Block wiring diagram

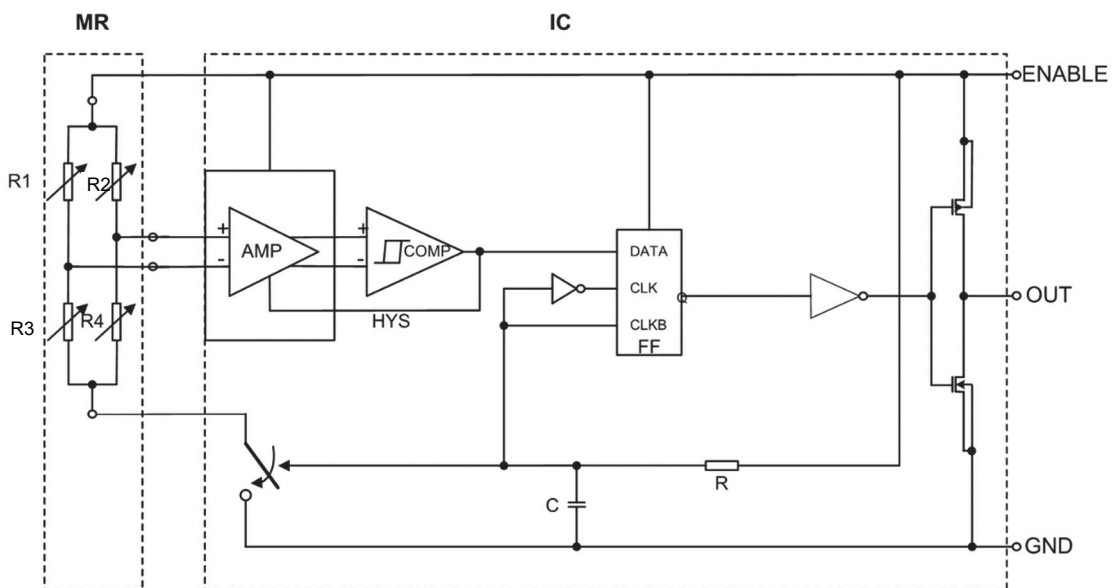

3-4 Example of enable control by microcomputer

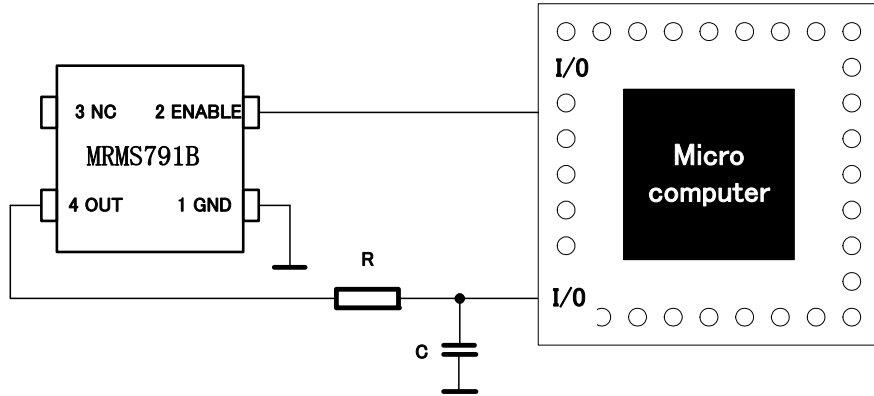

- NOTE1) Do not connect a DC power supply to the ENABLE/GND terminal (=Do not continuously energize long time with VIH). The sensor operating voltage VIH should be intermittently controlled by a microcomputer.
- NOTE2) Do not place a bypass capacitor between the ENABLE and GND terminals. The bypass capacitor may delay the rise of the Enable waveform and the sensor may not operate properly.
- NOTE3) The load resistance and capacitor of the OUT terminal vary depending on the microcomputer. Select one that does not affect the operation of the microcomputer. Please select it that is not affect the operation of the microcomputer.

3-5 Product operation

3-5-1 Timing chart

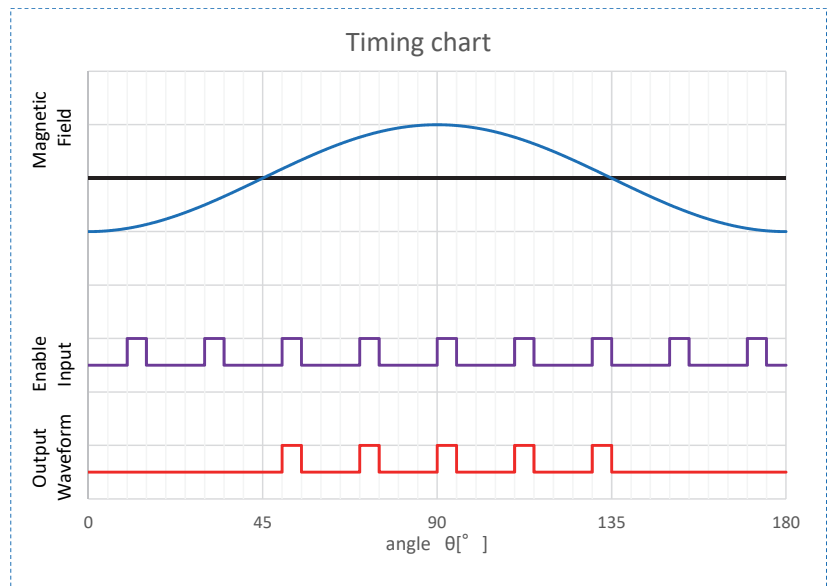
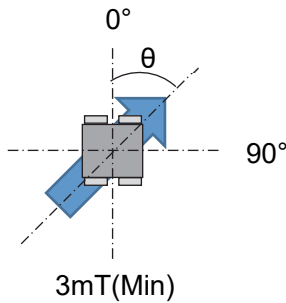

### 3-5-2 Sensor operation and current consumption

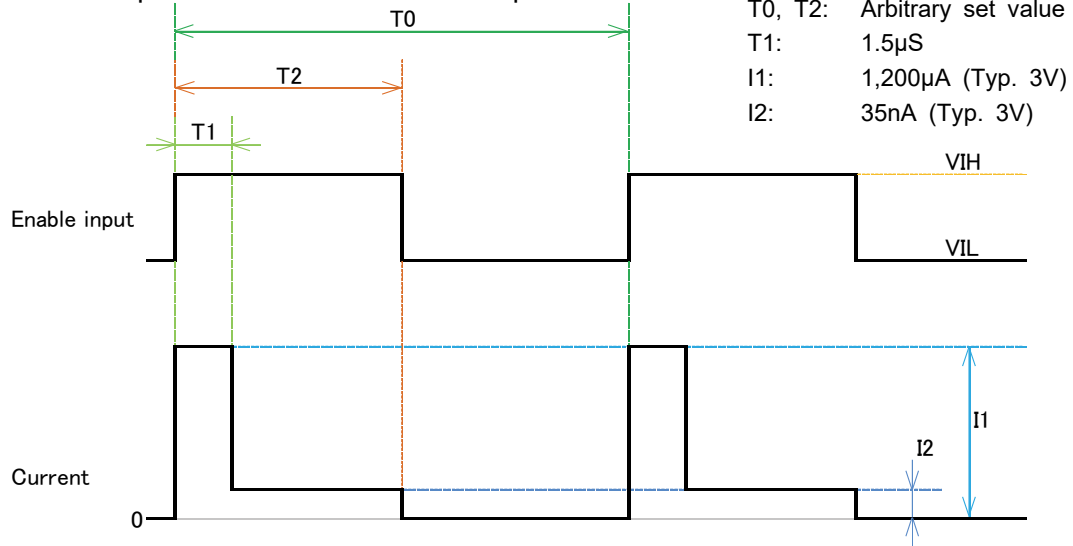

- The sensor operating voltage  $V_{IH}$  should be intermittently controlled by a microcomputer.
- While  $V_{IH}$  being applied, output determination is performed during  $T_1$  ( $= 1.5\mu\text{S}$ ), and the determination result is held during  $T_2$ .
- $T_2$  is the time required for the microcomputer side to feed back the output determination.
- $T_0$  is the period for one cycle intermittent control.
- The determination result is held until the input of Enable terminal changes from  $V_{IH}$  to  $V_{IL}$ . The determination result is not updated even if the  $V_{IH}$  is supplied continuously. (To update the output, Please set  $V_{IL}$  then set  $V_{IH}$  again.)

Example) In the case of 2 Hz sampling cycle, and the microcomputer read sensor output at  $40\mu\text{S}$ . The conditions for Enable operation are  $V_{IH} = 3.0\text{V}$ ,  $T_0 = 500\text{mS}$ ,  $T_2 = 40\mu\text{S}$ .

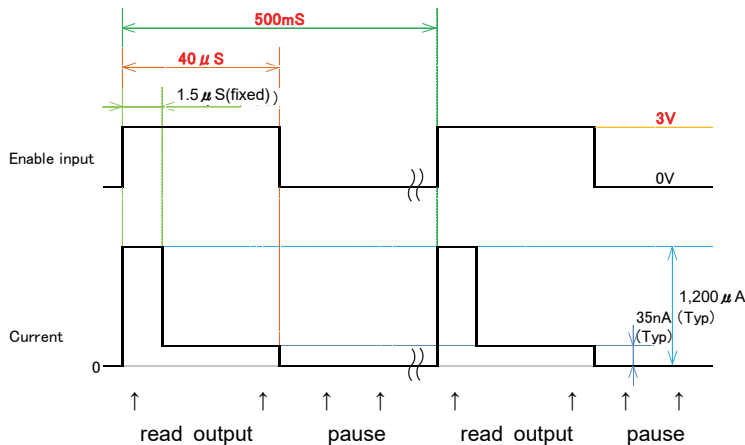

#### Conditions

- Enable is applied at  $3\text{V} \cdot 40\mu\text{S}$
- Operating cycle is  $500\text{mS}$  (2Hz)

#### Sensor operation

- After applying  $2.7\text{V}$  (90% of  $3.0\text{V}$ ) or more for  $0.5\text{s}$ , the measurement is completed at  $1.5\mu\text{S}$ , and sensor output voltage is set to the high/low level.
- The reading for sensor output is finished before  $T_2$  ( $40\mu\text{S}$ ).
- After  $T_2$ , the power supply to the sensor is stopped, and the operation is suspended until the next cycle (after  $500\text{mS}$ ).

## 3-6 Electric characteristics/ absolute maximum rating (Ta=+25±3°C)

	Parameter	Symbol	Conditions	Min.	Typ.	Max.	Unit
1	Enable voltage	V <sub>IH</sub>	—	1.8	3.0	3.6	V
2	Enable pulse boost time (10-90%)	T <sub>r</sub>	—	—	—	500	ns
3	Enable status current consumption	I <sub>IH</sub>	Peak	—	1.2	2.2	mA
4	Enable pulse frequency	F	—	—	100	3000	Hz
5	Enable pulse width	—	—	3	—	—	μs
6	Duty	—	V <sub>IH</sub> =3.0V No Load Resistance  Our measuring instrument	40	50	60	%
7	Output Voltage Hi	V <sub>OH</sub>	V <sub>IH</sub> =3.0V No Load Resistance	2.7	—	—	V
8	Output Voltage Lo	V <sub>OL</sub>		—	—	0.6	V
9	Operating temp. range	—	—	-30	—	+60	°C
10	Storage temp. range	—	—	-40	—	+125	°C
11	Power supply voltage absolute rating	—	—	—	—	6.0	V

NOTE1) Each specification is defined by testing above items individually.

NOTE2) When shifting the sensor output from H to L, please make sure the magnetic field applied to the sensor in the OFF direction becomes higher than 3.0mT through your designing.

NOTE3) When shifting the sensor output from L to H, please make sure the magnetic field applied to the sensor in the ON direction becomes lower than 3.0mT through your designing.

NOTE4) Sensitivity selection of this product is performed at Enable voltage V<sub>IH</sub>=3.0V. Operating magnetic field can possibly change when applying the supply voltage other than 3.0V. When using at a voltage other than 3.0V, please endure the magnetic field is sufficient for sensor operation.

NOTE5) The above specification is the limit value of our out-going inspection, and does not be guaranteed in your mounted state. Please certainly conduct evaluation after sensor mounting.

• Calculation of average current consumption

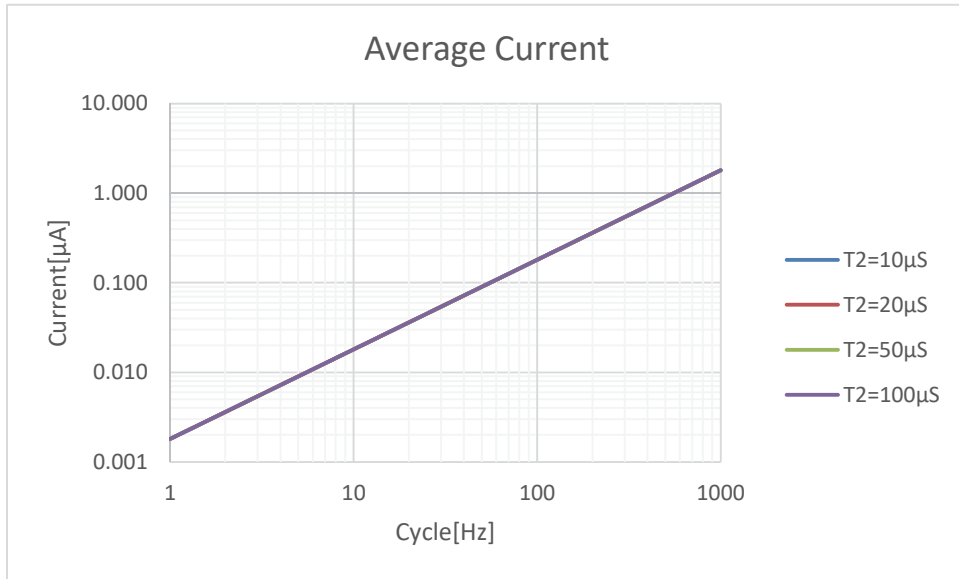

\*The average current consumption lave when  $V_{IH} = 3V$  is calculated as follows.

$$I_{ave} = (I_1 + I_2) \div T_0 \doteq I_1 \div T_0 = 1.8 \div T_0 = 1.8 \times 10^{-3} \times F [\mu A]$$

F is the frequency. Because I2 is much smaller than I1, there is almost no difference due to the difference in the current magnitude of T2.

Reference) Output current-output voltage relationship

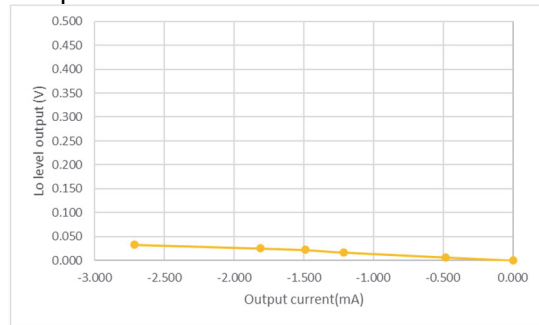
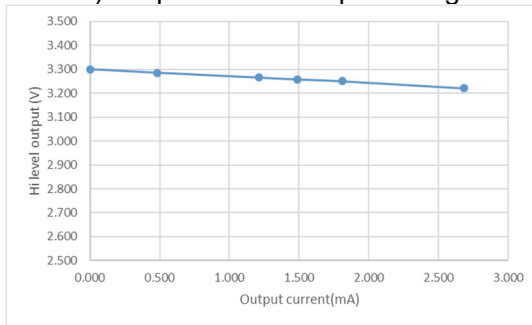

4. Packing information

4-1 Packing information

Form of packing	Reel dimension	Pcs per reel
Tape & reel	φ180	3000pcs

4-2 Taping specifications

4-2-1 Taping dimensions

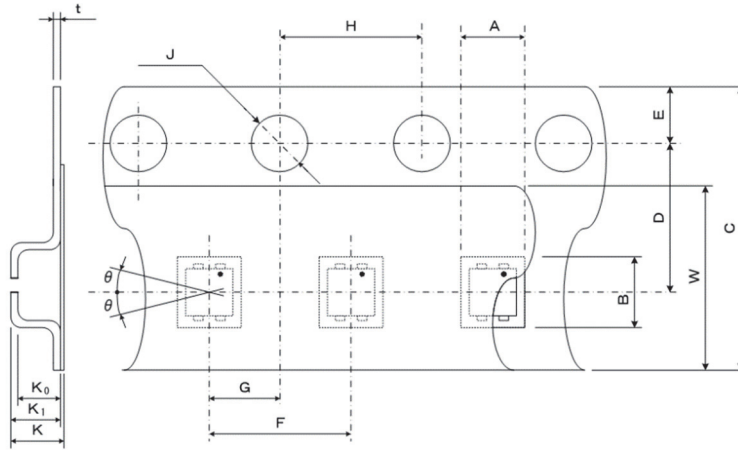

Unit:mm

Parameter		Symbol	Size/ Angle	Parameter		Symbol	Size/ Angle
Pocket	Length	A	1.75±0.05	Dist. Between center lines	L direction	G	2.0±0.05
	Width	B	2.00±0.05		W direction	D	3.5±0.05
	Depth	K <sub>0</sub>	0.85±0.05	Cover tape	Width	W	5.5 <sup>+0.3</sup> <sub>-0</sub>
	Pitch	F	4.0±0.1		Width	C	8.0±0.2
Feed hole	Diameter	J	φ1.5 <sup>+0.1</sup> <sub>-0</sub>	Carrier tape	Thickness	T	0.2±0.05
	Pitch	H	4.0±0.1		Depth	K <sub>1</sub>	1.05±0.1
	Position	E	1.75±0.1	Device	Tilt	θ	30°MAX
Overall thickness		K	1.03±0.1				

4-2-2 Reel dimensions...EIAJ PRV08B compliant

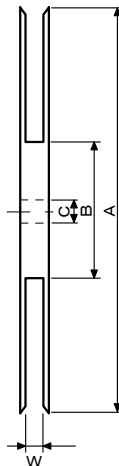
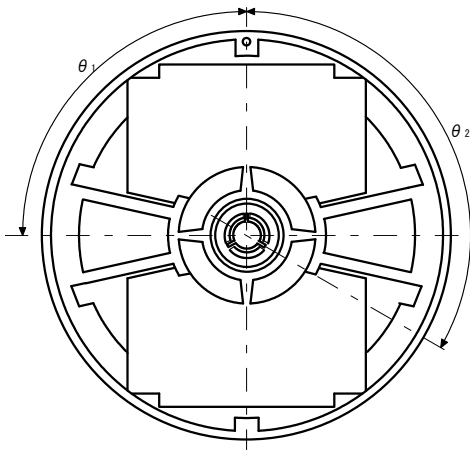

Unit: mm

Item	Symbol	Dim/Angle
Diameter	A	φ178±2
Dis. between flanges	W	9±0.5
Diameter	B	φ60±1
Hub slit position	θ <sub>1</sub>	90°
Spindle hole diam.	C	φ13±0.5
Key slit position	θ <sub>2</sub>	120°
Marking	Labeled on one side of flange	

4-2-3 Start/End of taping



Reel label A (example)

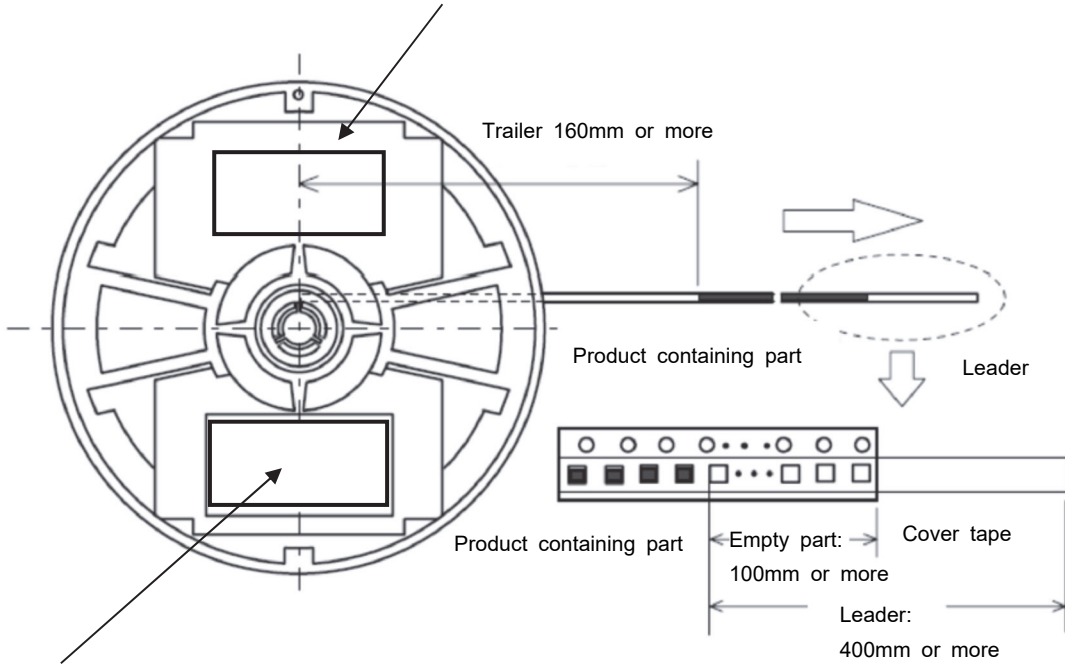

Reel label B (example)



4-2-4 Other notes

Continuously missing device shall not exceed 2 pcs.

Peeling strength of the cover tape: 0.1 to 0.7N.



4-3 Outer packing specifications

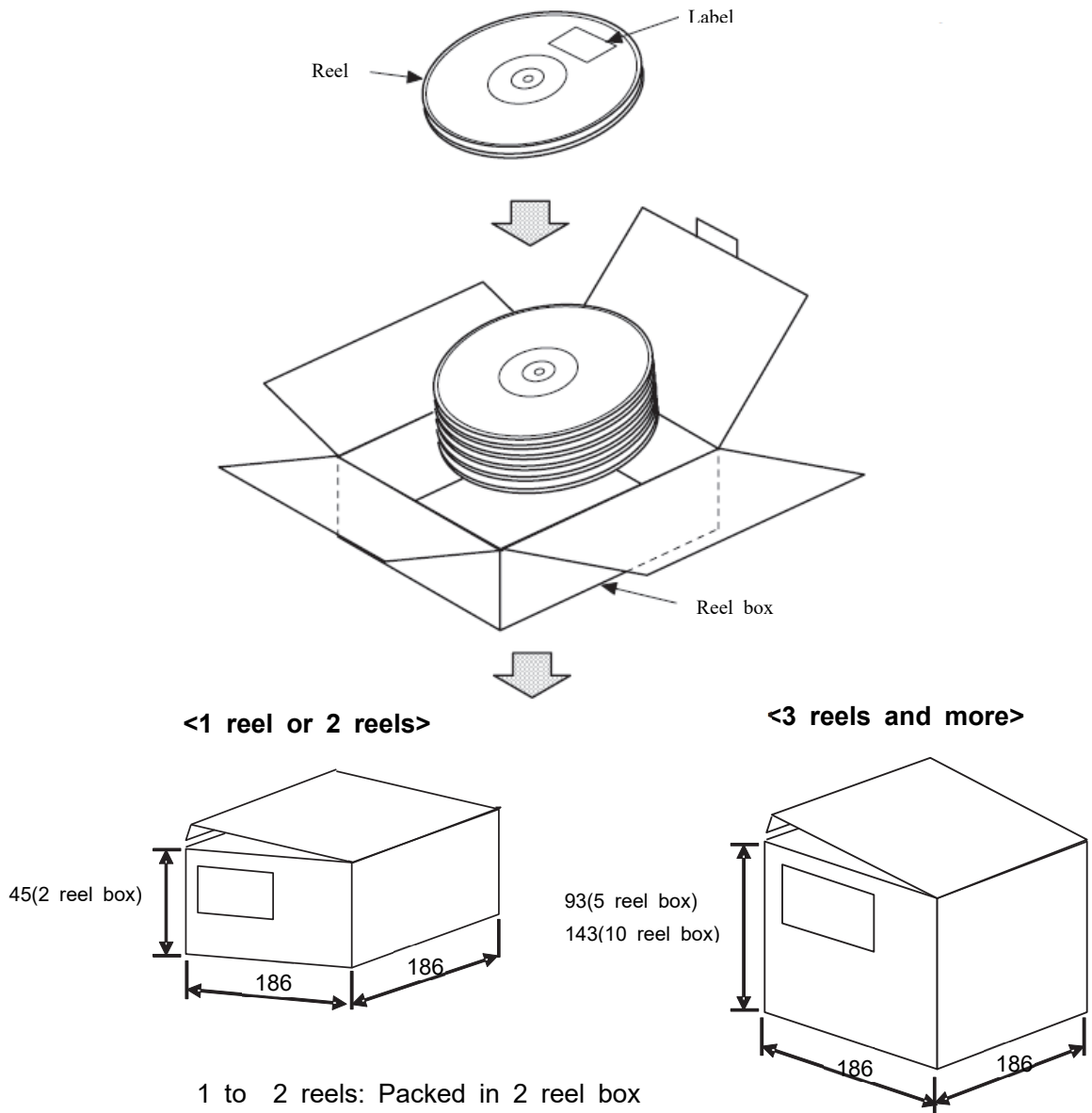

- 1 to 2 reels: Packed in 2 reel box
- 3 to 5 reels: Packed in 5 reel box
- 6 to 10 reels: Packed in 10 reel box

\*When the box is not filled with reels, antistatic buffer material will be used to avoid product from moving inside box.

\*Unit: mm, Tolerance: +/- 5mm

Material

Reel packing box: Cardboard

5. Mounting condition

5-1 Reflow condition

- Below is the maximum reflow condition for the product mounting.
- The temperature mentioned in below table and figure is package surface temperature.
- The absolute maximum package peak temperature is 260 °C and time within the temperature of 260 °C must not exceed 10 seconds (Requirement).

Profile Feature	Condition
<b>Pre-heating</b> Temperature Min. Temperature Max. Time from Temperature Min. to Max.	150 °C 180 °C 60-120 seconds
<b>Heating</b> Liquidous temperature Time maintained above Liquidous temperature  Peak package surface temperature Time at peak surface temperature	230°C 30 seconds max.  260°C 10 seconds max
Reflow times	3 times max.

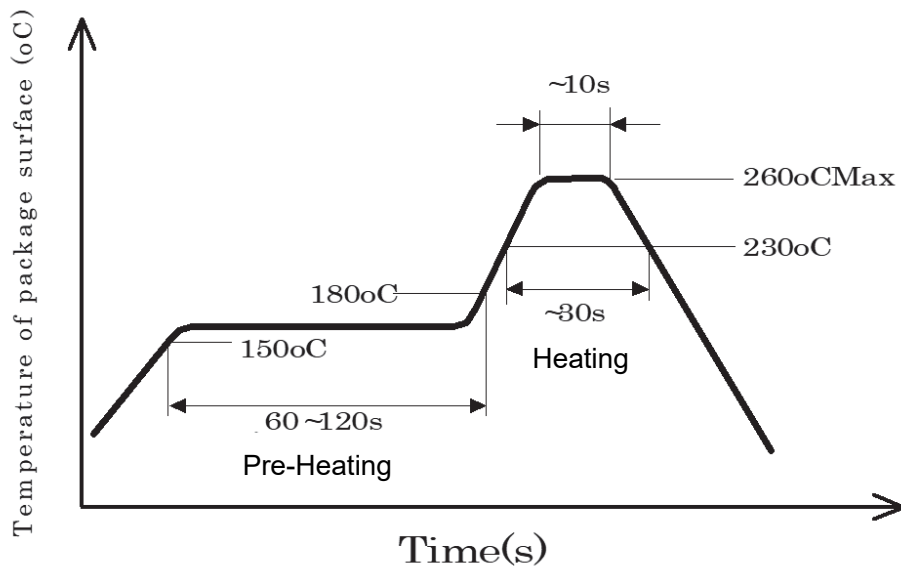

\*Recommendable Print Circuit Board : Glass epoxy PCB (FR-4) , t=1.6um

## 6. Reliability test

No.	Reliability test	Test conditions	Judgment criteria
1	High temp. storage	+125°C 500h No-load	<p>It shall be tested after being kept in a room over 2hours and Vcc=3.0V.</p> <p>• Output voltage Hi:2.7V or above Lo:0.6V or less</p>
2	Low temp. storage	-40°C 500h No-load	
3	High temp, high humidity load	+85°C 85%RH 500h Load voltage 3.0V	
4	Thermal shock	-55 °C /30 min ⇔ +125 °C /30min (vapor phase) 500 cycle, no-load	
5	Vibration	Apply vibration [Max amplitude: 1.5mm, frequency: 10 to 55Hz, 1 cycle minute, 3 directions, 2h in each direction (total 6h )]	
6	Shock test	Unpacked condition, X, Y, Z direction, 1470m/s <sup>2</sup> , 5 times/each	
7	Drop test	100g dummy load, Height: 150cm, on the concrete, 6 sides, 10 times/each	
8	Solder heat resistance	Pretreatment: +85°C, 85%RH, 168h Reflow condition: Max. 260°C & 230°C, 30 sec, times of reflow: 3	
9	Electrostatic resistance	Machine Model Condition: 200pF, Resistance: 0Ω, +/-200V Human Body Model Condition: 100pF, Resistance: 1.5kΩ, +/-2kV	
10	Solder ability	Solder temp.: +230°C, Time: 3 sec immersion	90% and more terminal surface covered with solder
11	Electrode sticking tendency	5N(510gf), 4 directions, 10 sec	No external abnormality found.
12	Bending cycle	Glass epoxy PCB, t=1.6, Speed: 5mm/min, 90mm span, bending range ±1mm, 1500 cycle	No terminal fracture, loosening found.
13	Bending limit	Glass epoxy PCB, t=1.6, 90mm span, bending range ±7mm.	

## 7. CAUTION

### 7-1 Limitation of Applications

Please avoid using this product for the applications listed below which require especially high reliability in order to prevent defects that might directly cause damage to the third party's life, body, or property.

When this product is used for the applications listed below, we shall not be liable for any claims on the product.

- ① Aircraft equipment
- ② Aerospace equipment
- ③ Undersea equipment
- ④ Generating plant equipment
- ⑤ Medical equipment
- ⑥ Transportation equipment (vehicles, trains, ships, etc.)
- ⑦ Traffic signal equipment
- ⑧ Disaster prevention/ crime prevention equipment
- ⑨ Data processing equipment
- ⑩ Application of similar complexity and/or reliability requirements to the applications listed above.

### 7-2 FAIL-SAFE

Be sure to provide appropriate fail-safe function on your product to prevent a second damage that may be caused by the abnormal function or the failure of our product.

## 8. CAUTION FOR USE

### 8-1 HANDLING

- This product may be degraded by electrostatic discharge. It is necessary to take anti-static precautions when handling.
- This sensor operates with the Enable pulse of power supply. Do not connect a DC power supply to the ENABLE / GND terminal (continuous energization with VIH for a long time). Otherwise it only holds the judgment result of the first cycle detection (no reaction to the following change of magnetic field), even the sensor may be damaged.

### 8-2 DESIGN

- Please carefully evaluate this product for the magneto-variation of the magnet used along with this product, otherwise this product may result in the miss-operation or the non-operation.
- Sensor miss-operation or non-operation may occur due to the influence of the magnetic noise from surrounding devices such as motor. Please make sure there is no influence of the magnetic noise in designing process.
- Please be careful about a magnetic body (Iron, Nickel, etc.) and a magnetic noise immunity that may affect the magnetism of a magnet.

### 8-3 Storage condition

- Recommended storage conditions are listed below.
  - Temperature: +5 to +30°C
  - Humidity: 70% (RH)% and lower
- \*Desiccator storage or storage in N<sub>2</sub> atmosphere is recommended.
- Allowable storage time of the product is one year from the date of delivery. Please take account of the storage conditions listed above. Please also use the product as soon as possible after opening the product packing to avoid the deterioration of solder ability.
- Please avoid the water, chemical solvent, or oil.
- Please avoid the corrosive gas (Cl<sub>2</sub> H<sub>2</sub>S, NH<sub>3</sub> NO<sub>2</sub>, NO<sub>3</sub> etc.)
- Please avoid the strong vibration or shock.

### 8-4 Mounting

- Please mount this product under standard reflow condition. Otherwise this product may be damaged.
- Hand soldering is not allowed for this product.
- Please do not apply excessive load to the terminals. Also, please do not bend the terminals.
- Please do not apply excessive bending stress to the product by bending the PCB or by similar handling as it may change the sensor sensitivity.
- Please make sure the mounting state of the sensor after mounting it. Depend on your application, mounting error may cause the sensor miss operation.

### 9. NOTE

- Make sure that your product has been evaluated in view of your specifications with our product being mounted to your product.
- Not to use our product deviating from the agreed specification.

# Mouser Electronics

Authorized Distributor

Click to View Pricing, Inventory, Delivery & Lifecycle Information:

[Murata:](#)

[MRMS791B](#)