

THESE INSTRUCTIONS SHOULD BE READ CAREFULLY AND RETAINED FOR FUTURE REFERENCE

IMPORTANT SAFETY ADVICE

This appliance can be used by children aged from 8 years and above and persons with reduced physical, sensory or mental capabilities or lack of experience or knowledge if they have been given supervision or instruction concerning the use of the appliance in a safe way and understand the hazards involved. Children shall not play with the appliance. Cleaning and user maintenance shall not be made by children without supervision. Children of less than 3 years should be kept away unless continuously supervised. Children aged from 3 years and less than 8 years shall only switch on/off the appliance provided that it has been placed or installed in its intended normal operating position and they have been given supervision or instruction concerning the use of the appliance in a safe way and understand the hazards involved. Children aged from 3 years and less than 8 years shall not plug in, regulate and clean the appliance or perform user maintenance.

CAUTION:

Some parts of this product can become very hot and cause burns. Particular attention has to be given where children and vulnerable people are present.

WARNING:

This heater is not equipped with a device to control room temperature. Do not use this heater in small rooms when they are occupied by persons not capable of leaving the room on their own, unless constant supervision is provided.

WARNING:

Do not operate the heater with the top cover removed. This could trip the fuselink. This heater must not be operated without the cover correctly in position.



This heater carries the warning symbol indicating that it must not be covered.

WARNING:

In order to avoid a hazard due to inadvertent resetting of the thermal cut-out, this appliance must not be supplied through an external switching device, such as a timer, or connected to a circuit that is regularly switched on and off by the utility.

DO NOT place the heater directly below a fixed socket outlet.

DO NOT place aerosols or other containers susceptible to heat in the direct airflow from the unit.

DO NOT use the heater in the immediate surroundings of a bath, a shower or a swimming pool.

IMPORTANT:

This heater must be installed so that the switches and other controls cannot be touched by a person in the bath or shower.

WARNING: Disconnect the heater from the electricity supply before undertaking service or repair.

WARNING:

If the appliance is fitted in a bathroom, a cable outlet will be necessary with the supply to the unit controlled by a double pole switch. The switch if inside the bathroom should be pull cord operated and if outside should be adjacent to the entrance door. The appliance must be mounted so that no part of it can be touched by any person using bath or shower.

DO NOT cover the appliance or place material or garments on it, or obstruct the air circulation around this appliance, for example with curtains or furniture, as this could cause over heating and a fire risk.

WARNING: The supply circuit to the heater must incorporate a double pole isolating switch having a contact separation of at least 3mm

This product is only suitable for well insulated spaces or occasional use

Dimensions (millimetres)

Model Specification

FX20VE: 1 or 2kW + electronic run-back timer

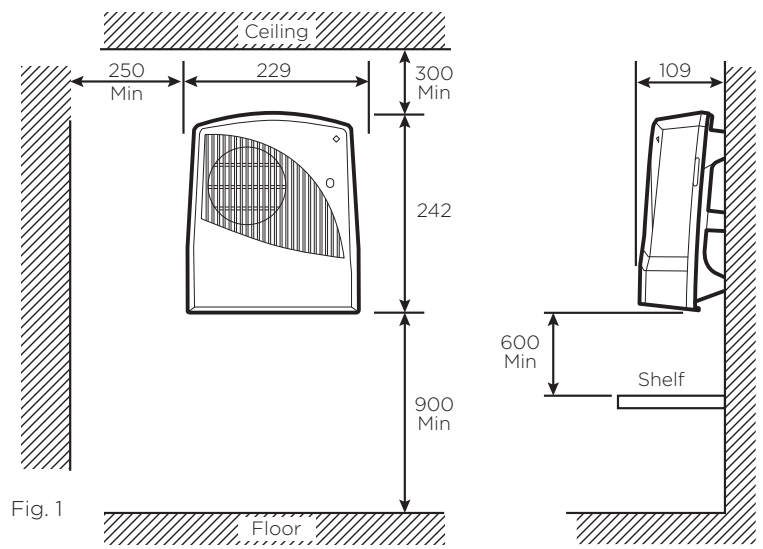

Fig. 1

General

Model Identifier(s)	FX20VE		
Heat output			
Nominal heat output	P _{nom}	2.0	kW
Minimum heat output (indicative)	P _{min}	1.0	kW
Maximum continuous heat output	P _{max,c}	2.0	kW
Auxillary electricity Consumption			
At nominal heat ourput	e _{lmax}	0.0	kW
At minimum heat output	e _{lmin}	0.0	kW
In standby mode	e _{lSB}	0.002	kW
type of heat output/room temperature control			
With electronic 30 minute runback timer	Yes		

Contact details

Glen Dimplex Heating and Ventilation, Millbrook House,
Grange Drive, Hedge End, Southampton, SO30 2DF

The heater has a loading of 2kW. It is designed for permanent wall mounting and is suitable for operation on A.C. electricity supply having the same voltage as shown on the rating label. The heater is fitted with an internally mounted selector switch which on installation of the heater allows a choice of 1kW or 2kW output to suit the dimensions of the room to be heated.

In rooms of less than 9 - 11 cubic m. (350 - 400 cubic ft.) 1kW output should be selected, otherwise nuisance tripping of the thermal overload cut-out may occur. The heater is fitted with an internally mounted selector switch which on installation of the heater allows a choice of 1kW or 2kW output to suit the dimensions of the room to be heated.

NOTE: The switch has been factory set for 1kW operation.
If additional output is required, 2kW can be set on installation.

Safety

Thermal Cut-Out & Electronic overheating protection

For your safety, this appliance is fitted with a thermal cut-out and also an electronic overheat protection device. In the event that the product overheats, these devices will switch the heater off automatically. To bring the heater back into operation, remove the cause of overheating, then turn off the electrical supply to the heater for a few minutes. When the heater has cooled sufficiently reconnect and switch on the heater. If the heater does not re activate it is possible that the fuselink has triggered, see Fuse link.

Fuse Link

A thermal fuse link is provided as an added safety feature. If the fuse link operates and opens circuit it is the result of abnormal overheating within the appliance. To ensure the future safe operation of the heater, please contact Dimplex Customer Services

Installation

WARNING: Minimum clearances must be adhered to when mounting the heater.

Supply cable is not supplied with this appliance and it should therefore be installed by a competent electrician in accordance with the latest IEE wiring regulations.

Before undertaking installation work, ensure the electricity supply is disconnected from any relevant fixed wiring.

The supply circuit must be adequate for the input of the appliance and must be protected with a 13A fuse. A suitable termination to the fixed wiring of the premises must be provided adjacent to the final position of the appliance through a double pole switch having a contact separation of at least 3mm in all poles.

Installation Procedure

It is essential to observe minimum wall mounting clearances - see Fig. 1. The appliance should be fitted horizontally, with the cable entry at the top and grille at the bottom. It must be mounted not less than 900mm above the floor with a clearance of at least 600mm to any shelf or projecting surface below the heater and not less than 300mm below the ceiling or other projecting surface. It must also be not less than 250mm from an adjacent projecting surface. For most effective heating performance, the heater should be mounted at the minimum height : i.e. 900mm above the floor. Care must be taken to ensure that when in use, the air stream is not obstructed. The appliance is secured to the wall with three screws, two through keyhole slots and one through a hole to hold the appliance firmly in position (see Fig. 2)

1. Remove the top cover from the appliance by removing the two screws securing the top cover and hinging it back.
2. Mark the position of the two keyhole slots (see Fig. 2 for dimensions) on the wall and drill and plug for the two suitable screws.
3. Partially insert the two screws, then hang the appliance on the screws. Mark the position of the third hole. This is used to secure the product.
4. Remove the appliance and drill and plug for the third screw.
5. Remount the appliance on the wall using the two keyhole slots.
6. Feed the supply cord or wires through the inlet at the top rear of the appliance leaving sufficient free length to connect to the terminal block.
7. Make electrical connections to the terminal block ensuring that the live connection is made to the terminal marked 'L' and the neutral connection to the terminal marked 'N' (see Fig. 2 detailed view).
8. Fix the product in place by inserting and tightening the third screw. Fix mains cable securely using the products cable clamp
9. Set the selector switch to provide either 1kW or 2kW output.
10. Replace the top cover and screws.

The appliance is now ready for use and the electricity supply can be reinstated.

WARNING: This product should never be operated without the top cover correctly installed. In this case, a replacement product or element would be required.

Fig. 2

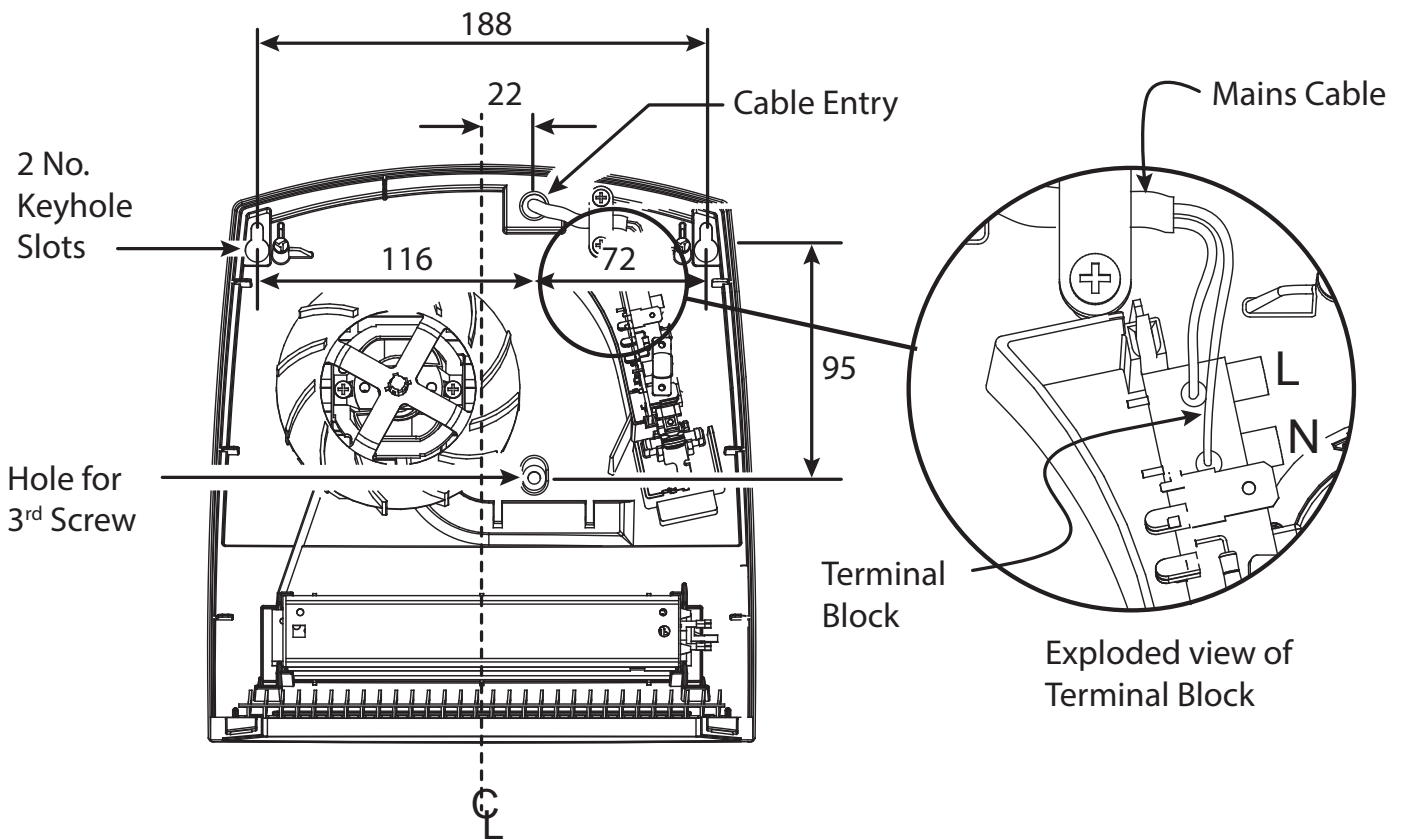

Controls

The heater can be switched on or off via the pull cord operation. The heater comes pre-programmed with a 30-minute runback timer. At the end of the runback period, the appliance can be restarted by pulling the cord twice; the red neon light will extinguish after the first pull, and will light up again after the second pull. The operation of the product can be stopped at any time during the 30 minute runback period by pulling the pull cord once, extinguishing the neon light. Pulling the cord again will restart the heat and fan, along with the red neon light.

NOTE: If the operation of the product has been stopped during a runback period then switched back on, the runback timer will revert back to the maximum 30 minute duration

Cleaning and User Maintenance

WARNING: Before undertaking cleaning or maintenance work on the appliance disconnect the electricity supply by switching off at the adjacent double pole switch.

The outside can be cleaned by wiping it over with a soft damp cloth and then dried. Do not use abrasive cleaning powders or furniture polish as this can damage the surface finish. Ensure that dust or fluff does not accumulate inside the heater as this could lead to overheating of the element. Use a vacuum cleaner to remove any fluff which does accumulate.

Recycling



For electrical products sold within the European Community. At the end of the electrical products useful life it should not be disposed of with household waste. Please recycle where facilities exist. Check with a Local Authority or retailer for recycling advice in your country. Batteries should be disposed of or recycled in accordance with WEEE Directive 2012/19/EU. Packaging should be recycled where possible.

What does a Dimplex Guarantee Cover?

Dimplex products deliver reliable service for normal, household use in domestic settings. All Dimplex products are individually tested before leaving the factory.

If you are a consumer and you experience a problem with your Dimplex product, which is found to be defective due to faulty materials or workmanship within the Guarantee Period, this Dimplex Guarantee will cover repair or - at the discretion of Dimplex - replacement with a functionally equivalent Dimplex product.

The Dimplex Guarantee Period is two calendar years from the date of purchase of your Dimplex product, or the date of delivery of the product, if later. The Dimplex Guarantee is conditional upon you providing the original purchase receipt as proof of purchase. Please therefore retain your receipt as proof of purchase.

If you do experience a problem with your Dimplex product please call the Helpline on **0344 879 3588** or visit <https://www.gdhv.com/contact-us> and complete the online form. For ROI please email serviceireland@glendimplex.com or call **+353(0)1 842 833**. We will need details of your Dimplex product, its serial number and a description of the fault which has occurred. You can find the model number and serial number for your Dimplex product on the appliance rating label. Once we receive your information and proof of purchase we will contact you to make the necessary arrangements.

If your Dimplex product is not covered by this Dimplex Guarantee there may be a charge to repair your product. However, we will contact you for agreement to any charges before any chargeable service is carried out

What is not covered by a Dimplex Guarantee?

The Dimplex Guarantee does not cover any of the following:

- Any fault or damage to your Dimplex product due to faulty materials or workmanship occurring outside the one-year Guarantee Period.
- Any fault or damage occurring to any pre-owned Dimplex product or to any other equipment or property.
- Accidental damage to your Dimplex product or damage to your Dimplex product from external sources (for example, transit, weather, electrical outages or power surges).

- Fault or damage to your Dimplex product which is:
 - Not due to faulty materials or workmanship or which is due to circumstances outside Dimplex control.
 - Caused by use of your Dimplex product for anything other than normal domestic household purposes in the country where it was purchased.
- Caused by any misuse, abuse or negligent use of the Dimplex product, including but not limited to any failure to use it in accordance with the Operating Instructions supplied with the product.
- Caused by any failure to assemble, install clean and maintain your Dimplex product in accordance with the Operating Instructions supplied with the product unless this was carried out by Dimplex or its authorised dealers.
- Caused by repairs or alterations to your Dimplex product not carried out by Dimplex service personnel or its authorised dealer(s).
- Caused by use of any consumables or spare parts for your Dimplex product which are not Dimplex - specified.

Terms and Conditions

- The Dimplex Guarantee is valid for Dimplex from the date of purchase of your Dimplex product from a recognised retailer in the country of purchase and use, or the date of delivery of the product if later, always provided the original receipt has been retained and is produced as proof of purchase.
- You must provide to Dimplex or its authorised agents on request the original receipt as proof of purchase and - if required by Dimplex - proof of delivery. If you are unable to provide this documentation, you will be required to pay for any repair work required.
- Any repair work under the Dimplex Guarantee will be carried out by Dimplex or its authorised dealer(s) and any parts that are replaced will become the property of Dimplex. Any repairs performed under the Dimplex Guarantee will not extend the Guarantee Period.
- Any replacement of your Dimplex product by Dimplex during the Guarantee Period will start the Dimplex Guarantee Period afresh from the date of delivery of the replacement Dimplex product to you.
- The Dimplex Guarantee does not entitle you to recovery of any indirect or consequential loss or damage including but not limited to loss or damage to any other property.
- The Dimplex Guarantee is in addition to your statutory rights as a consumer and your statutory rights are not affected by this Dimplex Guarantee.

Contact details

Glen Dimplex Heating and Ventilation, Millbrook House, Grange Drive, Hedge End, Southampton, SO30 2DF



Customer Helpline: 0344 879 3588
aftersales@dimplex.co.uk
www.dimplex.co.uk

Glen Dimplex Heating & Ventilation
Millbrook House, Grange Drive, Hedge End, Southampton, SO30 2DF