

PLIO strain relief bushes in flexible PVC 9542

(for technical properties see page D100)



PLIO

black

- 30 to + 70°C

type	article number	pack
14-542 PVC	0134 0001 010	100
14-581 PVC	0134 0004 010	100
14-582 PVC	0134 0005 010	100
14-583 PVC	0134 0006 010	100
14-908 PVC	0134 0010 010	100

14-1431 PVC	0134 0102 010	100
--------------------	---------------	-----

14-1017 PVC	0132 0910 010	100
--------------------	---------------	-----

14-1428 PVC	0134 0151 010	100
--------------------	---------------	-----

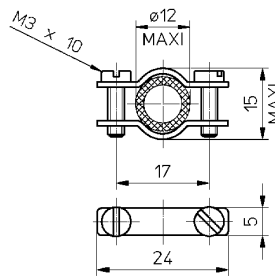

Metal clamp for bushes :
14-542, 14-582, 14-583, 14-908

type	article number	pack
16-900	0684 0054 000	100

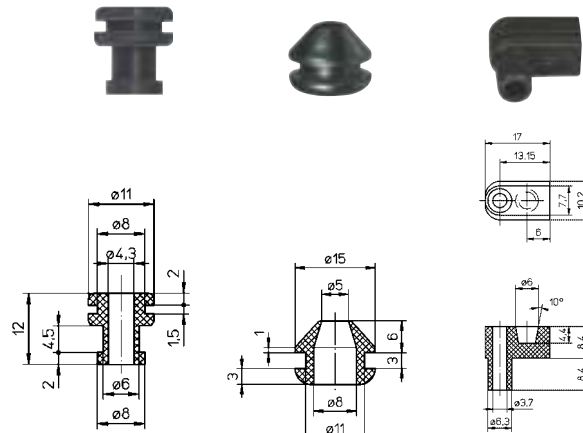

14-1017

0132 0910 010

14-1431

0132 0102 010

14-1428

0132 0151 010

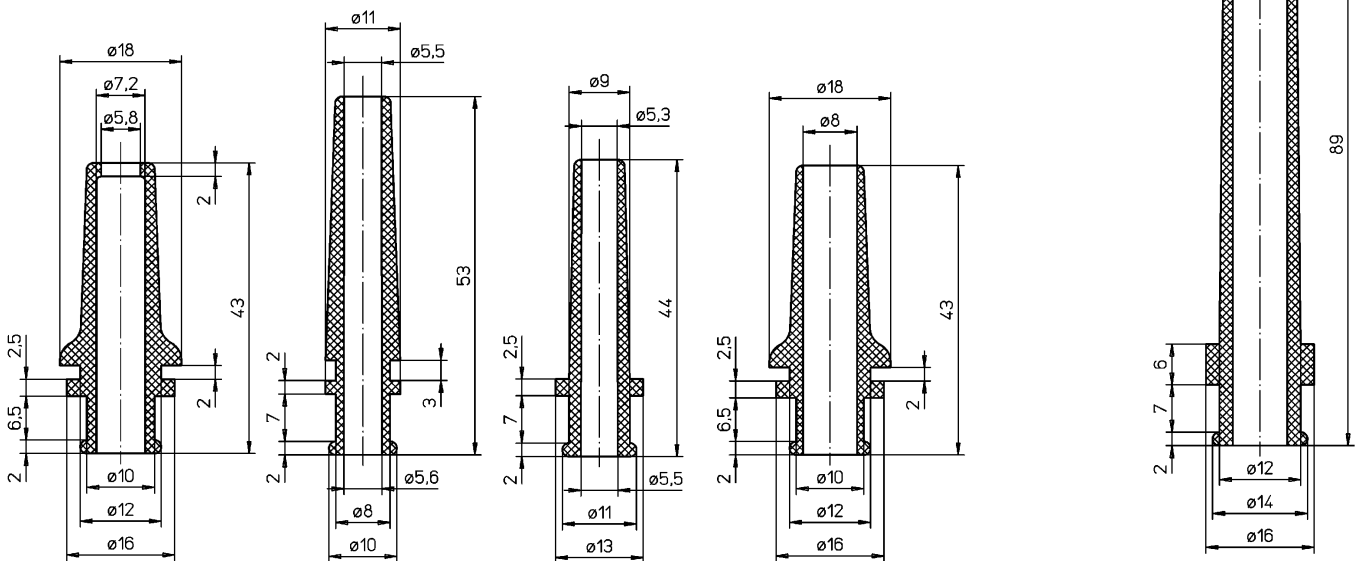

14-542

0134 0001 010

14-582

0134 0005 010

14-583

0134 0006 010

14-908

0134 0010 010

14-581

0134 0004 010



		Pages du catalogue Katalogseite Catalogue pages Página's in de catalogus Páginas del catálogo	Densité / Dichtheid Density / Dichtheid Densidad	Dureté / Härte / Hardness Hardheid / Dureza	Retrait longitudinal / Langsschrumpung longitudinal shrink / Krimp in de lengte richting Contracción longitudinal	Point de fusion / Schmelzpunkt Melting point / Smeltpunt Punto de fusión	Température d'utilisation Einsatztemperatur Operating temp. range Gebruikstemperatuur temp. de utilización	Temp. de retrait / Schrumpf temperatuur / Krimp temperatuur / temp. contracción	Résistance à la rupture / Rupture strength at break / Scher vastheid Resist. a la rotura	Allongement à la rupture Reissdehnung / Ultimate elongation Max. rek voor breuk Estramiento rotura	Resist. a base temp. Kaltbeständigkeit Low temp. resistance Lage temp.-bestendigheid Res. a bajas temp.
			g/cm ³	Sh A	%	°C	°C	°C	MPa	%	°C
HELAVIA	Qual. 3490	A1/1 A2/1		40 ±5			≤ +90		> 8	> 600	-30
SILAVIA	Qual. 2412	A1/3 A2/2		40 ±5			≤ +200		> 7	> 600	-80
PLIO-SUPER	Qual. 9923	A3/1 A3/2	1,30	90 ±5			≤ +90		24	300	≥ -20
PLIO-HT	Qual. 9861	A3/5-6	1,30	80 ±5			+105 continuous		20	300	-40 (norm ASTM)
PLIO-BT	Qual. 9863	A3/5-6	1,22	75 ±5			≤ +70		> 15	400	-50 chocs
PLIO tube	Qual. 9832	A3/7	1,23	85 ±5			≤ +60		> 22,5	350	-20
PLIO INDUS	Qual. 9836-10	A3/8	1,43	85 ±5			-30 to +85		15	250	
PLIO-R & R-VJ	Qual. 9901	A4/1	1,3	97 ±5	20 to 30		-20 to +90	+120	20	250	
PLIOFINE	SAM	A4/4			≤ 15			+90/100	> 12	> 200	
	B	A4/7	≤ 1,0		≤ -10			115	20	≥ 200	
	B-EX	A4/9	≤ 1,35		≤ -5			+90	15	≥ 300	
	BX-VJ	A4/11	≤ 1,35					≤ -10%	12,7		
	AD-UL3	A4/12	≤ 1,35		≤ +5-10				12	≥ 300	
PLIOSPIRE	Qual. PVC 9921	A5	1,30			+100	-15 to +80		25	300	
	Qual. PTFE		2,20			+325	-200 to +260		20	300	
	Qual. PA 6 BK (010)		1,08			+215	-40 to +120		35	240	
	Qual. PP BK (010)		0,92			+160	-40 to +90		30	500	
	Qual. PE NL (018)		0,90			+112	-50 to +85		12	550	
	Qual. PE BK (010)		0,95			+112	-50 to +85		12	550	
Qual. PE WH (001)	0,97			+112	-50 to +75		12	400			
PLIOSIL	PET	A6/1	1,38			260	-50 to +130			28	
	PA 6.6	A6/2	1,14			258	-55 to +135			25	
ELECTROFLEX	normal BK (010) calor BU (002) oil GH (003)	A7/1					-20 to +60 -10 to +90 -20 to +60		2 to 7,5 2 to 7,5 11,8	85 to 100 85 to 100 285	
POLYFLEX	PA 6	A7/3					-40 to +120		40-70		
HELAVIA	Polychloropren Nitrile EPDM	A20		40 to 60 60 ±5 50 to 80			-30 to +90 -25 to -100 -25 to +100		> 6 > 12 > 8	> 500 > 500 >200	- 30 - 25 - 25
PLIOPRENE	TPE TPE extra flexible	A21	1,0 0,9	60 ±5 40-45			-50 to +125 -40 to +70		> 4,5 8	> 300 600	
PLIO	PVC 9542	A22/1.5	1,2	60 ±5			≤ +70		10	> 350	-30
	PVC 9641	A22/10&11		70 ±5			≤ +75		13	350	-25
DM	PA 6	A22/20	1,13				+70 continuous +120 peak		50	45	-20
PLIO Pliocap	PE	A22/6	0,92				-50 to +85		11	> 200	
PLIO Caps	PP	A22/6	0,90				-40 to +85		28	12	
	PVC	A22/30	1,20				-25 to +75		13	350	
	PE	A22/30	0,92				-50 to +85		11	> 200	
	PA6/6	A22/30	1,14				-40 to +110		65	300	
	PA6	A22/30	1,13				-20 to +70		50	> 50	
	PP	A22/30	0,90				-25 to +90		26	8	
PLIOBORD	PE standard	A23/1	0,92				-50 to +85		> 12	> 550	-50
	PE non flammable	A23/1	0,97				-50 to +75		> 10	> 600	
A 720	A 720	A23/2-3					+105 continuous	+130			-55
SI-303	Silicone	A23/2-3	1,17				-70 to +250			> 400	
PLIOPLAST	PLIOPLAST 15	A23/4							> 2,8	> 150	
	PLIOPLAST 18		> 3,5	> 250							
	PLIOPLAST 25		> 5,4	> 175							



		Pages du catalogue Katalogseite Catalogue pages Páginas in de catalogus Páginas del catálogo	Resistivité transversale Durchgangswiderstand Volume resistivity Dwarsweerstand Resistividad transversal	Constante diélectrique Dielektrischer Faktor Dielectric constant Dielectrische constante Constante dieléctrica	Rigidité diélectrique Durchschlagfestigkeit Dielectric strenght Dielectrische constante Rigidez dieléctrica	Tenue à la flamme Brandverhalten Flame resistance Brandbestandigheid Comport. ante llama	Corrosivité / Korrosion Corrosion / Corrosiegedrag Corrosividad	Absorption d'eau / Wasseraufnahme Water Absorption / Vochtabsorptie Absorción de agua	Indice d'oxygene / Sauerstoffindex Limiting oxygen index (LOI) Zuurstoffindex / Índice de oxígeno
			Ohm x cm		kV/mm			%	%
HELAVIA	Qual. 3490	A1/1 A2/1	4 x 10 ⁹		> 13	UL 94-V0/M3			28
SILAVIA	Qual. 2412	A1/3 A2/2	10 ¹⁵		18				
PLIO-SUPER	Qual. 9923	A3/1 A3/2	to 20°C : 3x10 ¹²		20	UL94-V2			
PLIO-HT	Qual. 9861	A3/5-6			> 20	UL94-V0			
PLIO-BT	Qual. 9863	A3/5-6							
PLIO Tube	Qual. 9832	A3/7	to 20°C : 1x10 ¹³		> 20				
PLIO INDUS.	Qual. 9836-10	A3/8							
PLIO-R & R-VJ	Qual. 9901	A4/1	10 ¹²		20	UL94-V0		0,2	
PLIOFINE	SAM B B-EX BX-VJ AD-UL3	A4/4 A4/7 A4/9 A4/11 A4/12	> 10 ¹⁴ 10 ¹⁵ 10 ¹⁴ 10 ¹⁴ 10 ¹⁰		> 20 25 20 20 16	VV-UL 224 self-extinguishing except transparent		≤ 0,2 ≤ 0,5 ≤ 0,5 ≤ 1,0	
PLIOSPIRE	Qual. PVC 9921 Qual. PTFE Qual. PA 6 BK (010) Qual. PP BK (010) Qual. PE NL (018) Qual. PE BK (010) Qual. PE WH (001)	A5		4 2,0 3,7 2,5 2,2 2,2 2,2	20 50 16 > 25 > 25 > 25 > 25	UL94-V0 HB UL94-V2		0 2 < 0,1 < 0,1 < 0,1 < 0,1	0,1
PLIOSIL	PET PA 6.6	A6/1 A6/2				UL94-V2			27,5 26,5
ELECTROFLEX	normal BK (010) calor BU (002) oil GH (003)	A7/1			4 4 4	UL94-V0 UL94-V0			
POLYFLEX	PA 6	A7/3	10 ¹²						
HELAVIA	Polychloropren Nitrile EPDM	A20	> 4x10 ⁸ 10 ¹⁰		> 13 12 max.				
PLIOPRENE	PLIOPRENE TPE PLIOPRENE TPE extra souple	A21	9 x 10 ¹⁴ 10 ¹⁴		35 30				
PLIO	PVC 9542 PVC 9641	A22/1.5 A22/10 & 11	10 ¹³		> 20	UL94-HB			
DM	PA 6	A22/20	10 ¹³	3,2	50	UL94-V2		2,5	
PLIO Passe-fils Pliocap	PE	A22/6	10 ¹⁶		> 16	-		< 0,1	
PLIO Capuchons	PP	A22/6	10 ¹⁶		> 20	-		< 0,1	
	PVC	A22/30	10 ¹³		> 20	-		< 0,1	
	PE	A22/30	10 ¹⁶		> 16	-		< 0,1	
	PA6/6	A22/30	10 ¹⁴		26	UL94-V2		2,5	
	PA6	A22/30	10 ¹²		60	UL94-V2		-	
	PP	A22/30	> 10 ¹⁷		50	-		< 0,1	
PLIOBORD	PE standard PE non inflammable	A23/1	10 ¹⁷ 10 ¹⁷	2,2 2,2	60 60	- UL94-V2		< 0,1 < 0,1	
A 720	A 720	A23/2-3			30		Nulle T° lim. util.		
SI-303	Silicone	A23/2-3	10 ¹⁵	2,9	16				
PLIOPLAST	PLIOPLAST 15 PLIOPLAST 18 PLIOPLAST 25	A23/4				self-extinguishing	1 1 1		