

TGS 826 - for the Detection of Ammonia

Features:

- * High sensitivity to ammonia
- * Quick response to low concentrations of ammonia
- * Uses simple electrical circuit
- * Ceramic base resistant to severe environment

Applications:

- * Ammonia leak detection in refrigerators
- * Ventilation control for the agricultural and poultry industries

The sensing element of TGS826 is a metal oxide semiconductor which has low conductivity in clean air. In the presence of a detectable gas, the sensor's conductivity increases depending on the gas concentration in the air. A simple electrical circuit can convert the change in conductivity to an output signal which corresponds to the gas concentration.

The TGS826 has high sensitivity to ammonia gas. The sensor can detect concentrations as low as 30ppm in the air and is ideally suited to critical safety-related applications such as the detection of ammonia leaks in refrigeration systems and ammonia detection in the agricultural field.

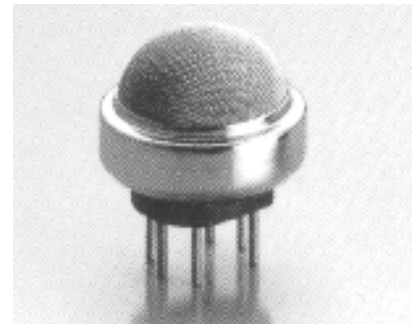

The figure below represents typical sensitivity characteristics, all data having been gathered at standard test conditions (see reverse side of this sheet). The Y-axis is indicated as *sensor resistance ratio* (R_s/R_o) which is defined as follows:

- R_s = Sensor resistance of displayed gases at various concentrations
- R_o = Sensor resistance at 50ppm of ammonia

Sensitivity Characteristics:

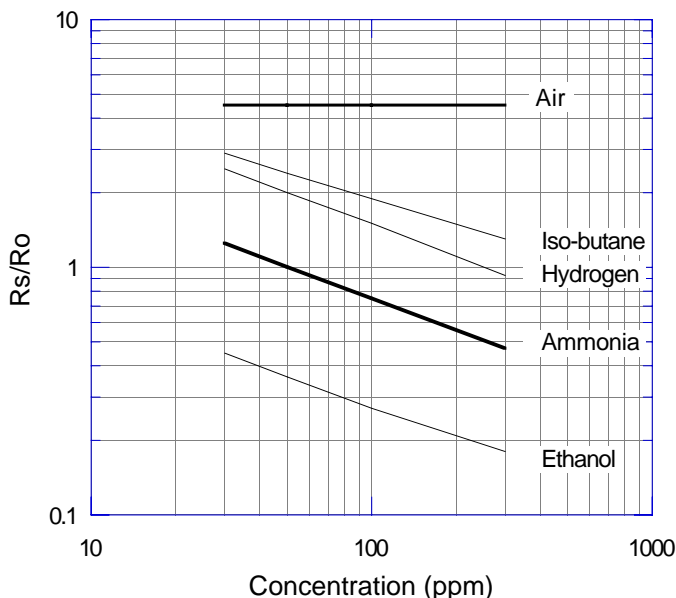

The figure below represents typical temperature and humidity dependency characteristics. Again, the Y-axis is indicated as *sensor resistance ratio* (R_s/R_o), defined as follows:

- R_s = Sensor resistance at 50ppm of ammonia at various temperatures/humidities
- R_o = Sensor resistance at 50ppm of ammonia at 20°C and 65% R.H.

Temperature/Humidity Dependency:

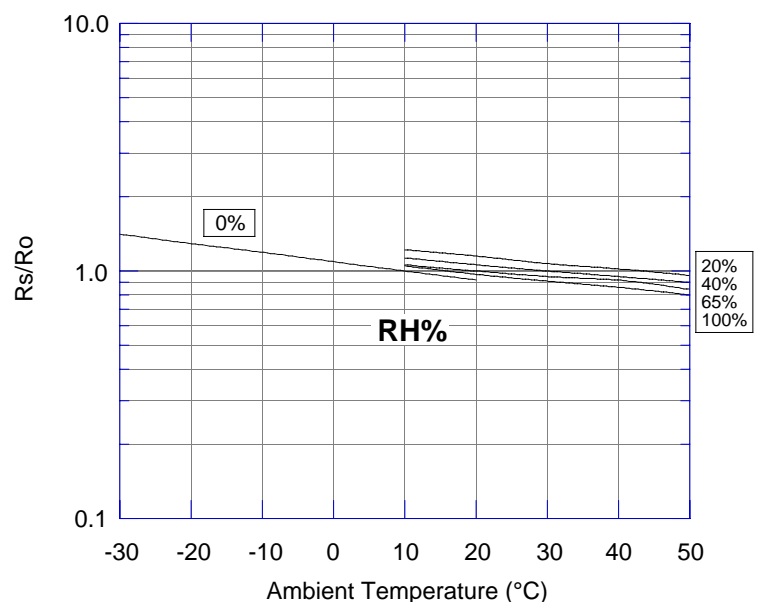

IMPORTANT NOTE: OPERATING CONDITIONS IN WHICH FIGARO SENSORS ARE USED WILL VARY WITH EACH CUSTOMER'S SPECIFIC APPLICATIONS. FIGARO STRONGLY RECOMMENDS CONSULTING OUR TECHNICAL STAFF BEFORE DEPLOYING FIGARO SENSORS IN YOUR APPLICATION AND, IN PARTICULAR, WHEN CUSTOMER'S TARGET GASES ARE NOT LISTED HEREIN. FIGARO CANNOT ASSUME ANY RESPONSIBILITY FOR ANY USE OF ITS SENSORS IN A PRODUCT OR APPLICATION FOR WHICH SENSOR HAS NOT BEEN SPECIFICALLY TESTED BY FIGARO.

Structure and Dimensions:

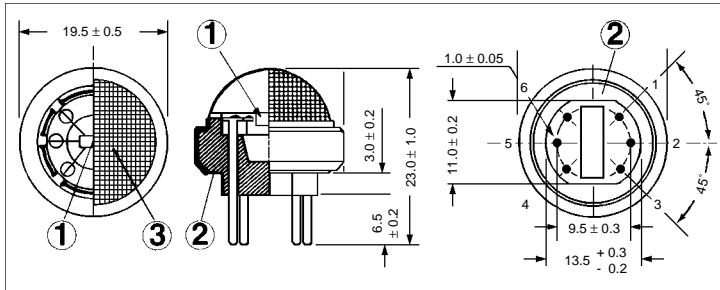

- ① Sensing Element:
Metal oxide is sintered to form a thick film on the surface of an alumina ceramic tube which contains an internal heater.
- ② Sensor Base:
Alumina ceramic
- ③ Flame Arrester:
100 mesh SUS 316 double gauze

Pin Connection and Basic Measuring Circuit:

The numbers shown around the sensor symbol in the circuit diagram at the right correspond with the pin numbers shown in the sensor's structure drawing (above). Since the sensor has a polarity, DC voltage is always required for circuit voltage (a white dot indicates pin 2). When the sensor is connected as shown in the basic circuit, output across the Load Resistor (V_{RL}) increases as the sensor's resistance (R_s) decreases, depending on gas concentration.

Basic Measuring Circuit:

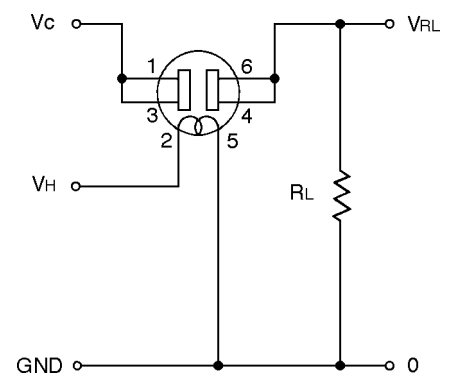

Pin #2 is indicated by a white dot on the sensor's base.

Specifications:

Model number		TGS 826	
Target gases		Ammonia	
Typical detection range		30 ~ 300 ppm	
Standard circuit conditions	Heater Voltage	V_H	5.0±0.2V DC/AC
	Circuit voltage	V_C	Max. 24V (DC only) $P_s \leq 15mW$
	Load resistance	R_L	Variable $P_s \leq 15mW$
Electrical characteristics under standard test conditions	Heater resistance	R_H	30±3Ω at room temp.
	Heater current	I_H	167mA
	Heater power consumption	P_H	833mW $V_H = 5.0V$ DC
	Sensor resistance	R_s	20~100kΩ in 50ppm ammonia
	Sensitivity (change ratio of R_s)		0.55 ± 0.15 $\frac{R_s(150ppm)}{R_s(50ppm)}$
Standard test conditions	Test gas conditions	Ammonia in air at 20±2°C, 65±5%RH	
	Circuit conditions	$V_C = 5.0±0.01V$ DC $V_H = 5.0±0.05V$ DC $R_L = 33kΩ±1%$	
	Conditioning period before test	7 days	

Sensor Resistance (R_s) is calculated by the following formula:

$$R_s = \left(\frac{V_C}{V_{RL}} - 1 \right) \times R_L$$

Power dissipation across sensor electrodes (P_s) is calculated by the following formula:

$$P_s = \frac{V_C^2 \times R_s}{(R_s + R_L)^2}$$

Special Note: A more narrowly defined range of R_s or R_s/R_o will be indicated on each production lot (see Appendix). Preselected ranges of R_s or R_s/R_o are not available.

For information on warranty, please refer to Standard Terms and Conditions of Sale of Figaro USA Inc.

FIGARO USA, INC.

3703 West Lake Ave. Suite 203
Glenview, Illinois 60025
Phone: (847)-832-1701
Fax: (847)-832-1705
email: figarousa@figarosensor.com

Appendix

TGS 826 Pre-Sorted Groupings

The TGS 826 sensor has a wide specification range in terms of its rated value in 50ppm of NH₃ and sensor resistance ratio (Rs in 150ppm of NH₃ / Rs in 50ppm of NH₃). To facilitate usage of this sensor, TGS 826 is shipped in pre-sorted groupings of 20 pieces per bag, with each bag marked with one of the following group numbers which indicate a more narrow range within the specification.

Please be advised that the sensor is produced to meet the overall specification range--production of specific groupings within the spec cannot be done. As a result, if a user requests a specific group(s), the sensor can be made available at an additional charge, but no guarantee can be offered as to availability for shipment. The minimum delivery time for special group selection should be considered at 8 weeks minimum.

Group #	Rs in 50ppm of NH ₃ (kΩ)			<u>Rs (in 150ppm of NH₃)</u> <u>Rs (in 50ppm of NH₃)</u>		
	1-A	20 ~ 30			0.4 ~ 0.5	
1-B	20 ~ 30				0.5 ~ 0.6	
1-C	20 ~ 30					0.6 ~ 0.7
2-A		30 ~ 40		0.4 ~ 0.5		
2-B		30 ~ 40			0.5 ~ 0.6	
2-C		30 ~ 40				0.6 ~ 0.7
3-A			40 ~ 53	0.4 ~ 0.5		
3-B			40 ~ 53		0.5 ~ 0.6	
3-C			40 ~ 53			0.6 ~ 0.7
4-A	53 ~ 70			0.4 ~ 0.5		
4-B	53 ~ 70				0.5 ~ 0.6	
4-C	53 ~ 70					0.6 ~ 0.7
5-A		70 ~ 85		0.4 ~ 0.5		
5-B		70 ~ 85			0.5 ~ 0.6	
5-C		70 ~ 85				0.6 ~ 0.7
6-A			85 ~ 100	0.4 ~ 0.5		
6-B			85 ~ 100		0.5 ~ 0.6	
6-C			85 ~ 100			0.6 ~ 0.7