

Visual Signals - Light Commercial LED ECO BEACONS

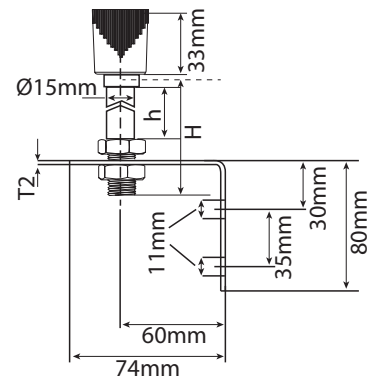
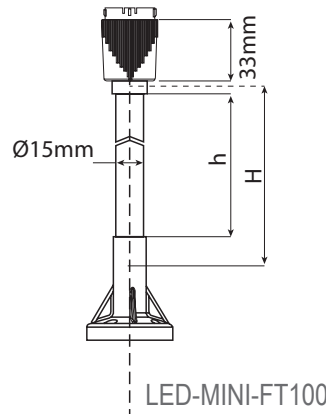

Light Commercial LED ECO Beacons > LED-MINI Series (30mm diameter)

Product overview

The LED Mini tower light modules are ideally suited for status indication in light commercial signalling applications where a low cost, compact and local signal is required. These beacons are of the continuous/static mode type (single stage alarm) Once the beacon is energised the LED's will stay permanently on.

An advantage of this type of operation is that It can be controlled via a remote

source (ie control panel / plc etc) giving the beacon greater flexibility by offering a (flashing) second stage alarm.

The design is modular and is easily assembled. Colour modules are supplied with quick fix termination that simply push into male terminals in the module below to make the connection.

The two base mounting options are available, Foot & 100mm pole or a Side Bracket & 100mm pole each base is supplied with a 1 metre flying lead.

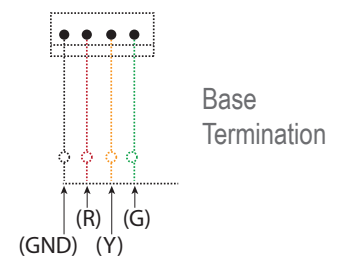
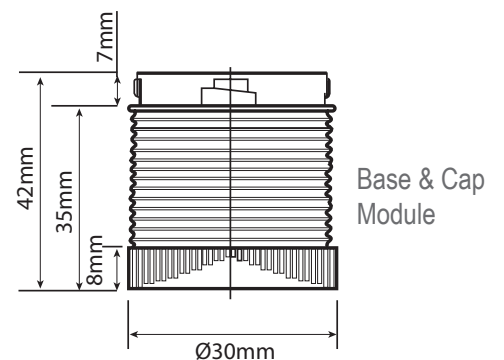

Features

- Continuously rated
- LED long life
- Low current consumption
- Economical
- 360° light output around the vertical axis

Material

UV Stable Polycarbonate Lens
UV Stable Polycarbonate Base

LED-TLM Series > Ordering Information

Code No:	Voltage:	Light Source:	Current:
LED-MINI-02	12/24v Dc ---	8 SMT LEDs	80mA • 45mA ••
LED-MINI-FT100	Mounting Base, Foot & Pole 100mm		
LED-MINI-BR100	Mounting Base, Bracket & Pole 100mm		

- @ 12v
- @ 24v

ADD THE FOLLOWING LENS CODES TO THE PRODUCT WHEN ORDERING



Kg 0.2 Module
0.23 Bracket
0.15 Foot

°C -20+66

IP 54

APPROVALS and
CONFORMITIES

