

THIS DRAWING IS UNPUBLISHED. RELEASED FOR PUBLICATION
 © COPYRIGHT BY TYCO ELECTRONICS CORPORATION. ALL INTERNATIONAL RIGHTS RESERVED.

LOC	DIST	REVISIONS					
AF	50	P	LTR	DESCRIPTION	DATE	DWN	APVD
		AC1		REVISED PER ECR-08-017312	16JUL08	HMR	PD

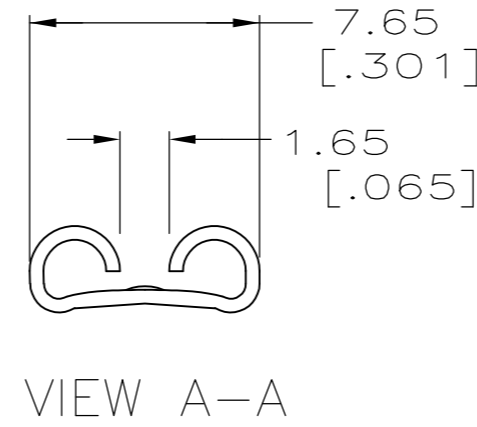

- 1 DIM'S IN BRACKETS ARE IN INCHES.
- 2 CONTINUOUS STRIP ON REELS.
- 3 FOREIGN PRODUCTION ONLY.
- 4 MATING TAB THK IS 0.81±0.025[.032±.001].
- 5 WIRE SIZE IS [#14-#10] AWG.
- 6 INSULATION DIA IS 3.81-5.08 [.150-.200].
- 7 REVERSE REELING W/ PAPER INTERLEAVING
- 8 PRELIMINARY - NOT FOR PRODUCTION
- 9 FOR AMP ITALY ONLY, NOT STRESS RELIEVED.

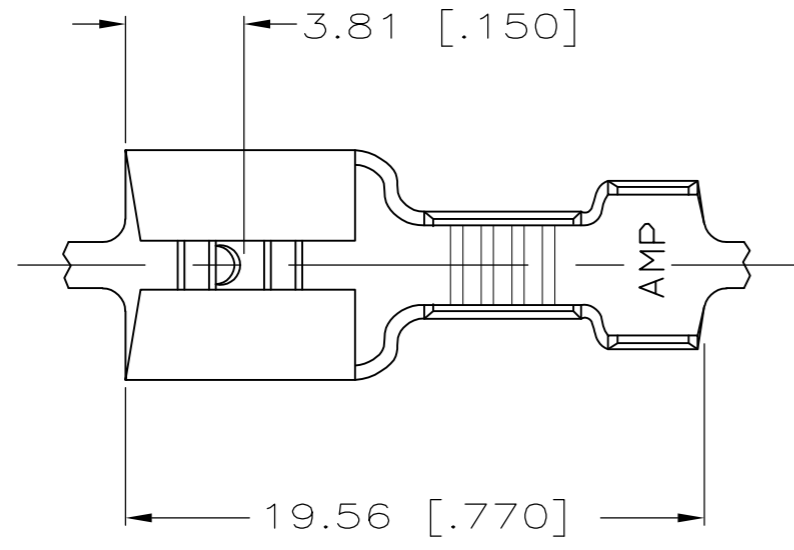
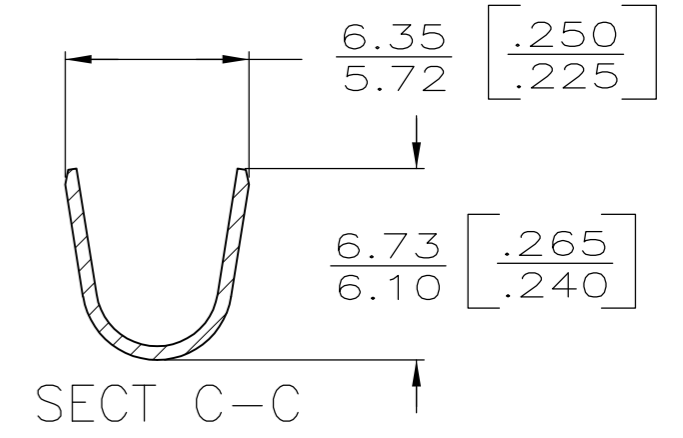
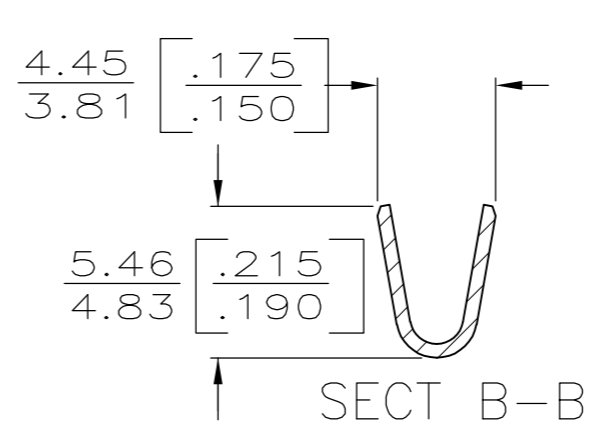
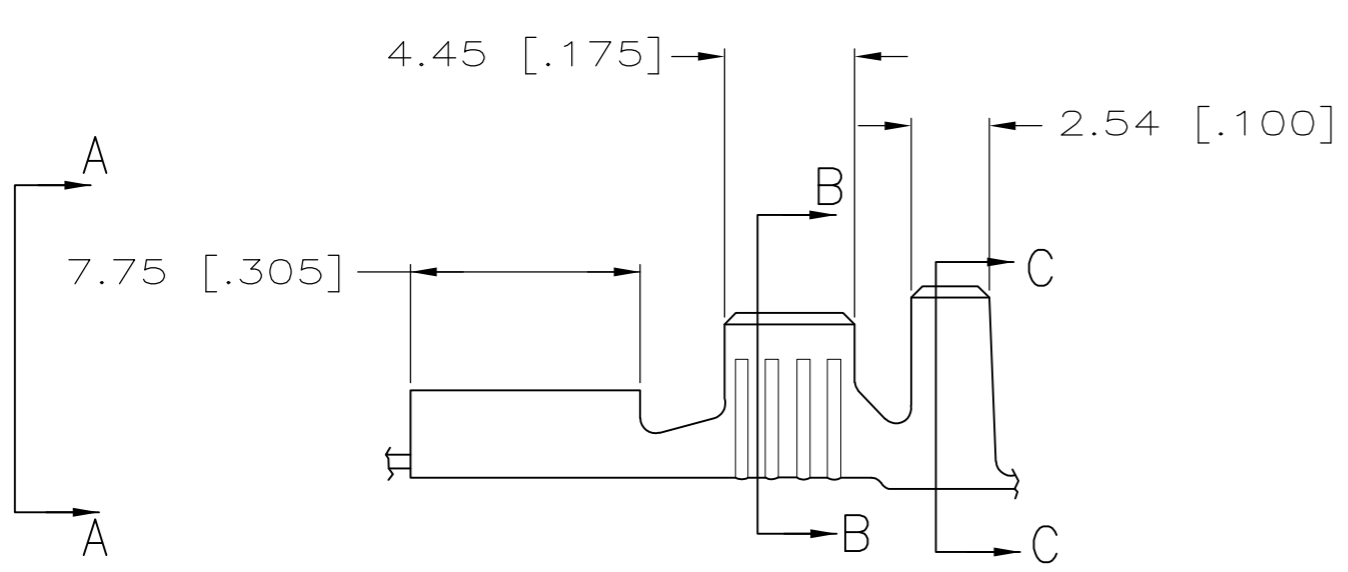

0.46 [.018] BRASS	9	1-41450-1
0.46 [.018] BRASS	7	41450-3
0.46 [.018] PHOS BRZ	3	41450-2
0.46 [.018] BRASS	3	41450-1
0.46 [.018] BRASS		41450
MATERIAL	PART NO	

0	5.33 [.210]	5.59 [.220]	F	3.30 [.130]	2.90 [.114]	5.0mm ² [10]
TYPE	WIDTH	STRIP LENGTH ±0.38 [±.015]	TYPE	WIDTH	±.051 [±.002] HEIGHT	WIRE
INSUL BARREL CRIMP	WIRE BARREL CRIMP					

THIS DRAWING IS A CONTROLLED DOCUMENT.

DIMENSIONS: INCHES

TOLERANCES UNLESS OTHERWISE SPECIFIED:

0 PLC	± -
1 PLC	± -
2 PLC	± 0.25 [.010]
3 PLC	± -
4 PLC	± -
ANGLES	± -

MATERIAL: SEE TABLE

FINISH: TIN PLATE

DWN: JR RUTH 2/7/86

CHK: G YETTER 2/7/86

APVD: R KUZO 2/7/86

PRODUCT SPEC: -

APPLICATION SPEC: -

WEIGHT: -

CUSTOMER DRAWING

Tyco Electronics Tyco Electronics Corporation
Harrisburg, PA 17105-3608

NAME: RECEPTACLE, FASTON, .250 SERIES

SIZE: A3	CAGE CODE: 00779	DRAWING NO: C-41450	RESTRICTED TO: -
----------	------------------	---------------------	------------------

SCALE: 4:1 SHEET: 1 OF 1 REV: AC1