

---

**SAM E51 Integrated Graphics and Touch Curiosity User Guide**

---

**Preface**

---

The SAM E51 Integrated Graphics and Touch Curiosity Evaluation Kit (EV14C17A) is a hardware platform for evaluating the SAME51J20A microcontroller. The evaluation kit integrates a complete touch screen, TFT graphics and touch surface into a single-chip solution supported by the MPLAB® X Integrated Development Environment (IDE). The evaluation kit provides easy access to the features of the SAME51J20A to integrate the device into a custom design. The Integrated Graphics and Touch Curiosity Evaluation kit includes an On-Board Debugger, therefore no external tools are necessary to program the SAME51J20A device.

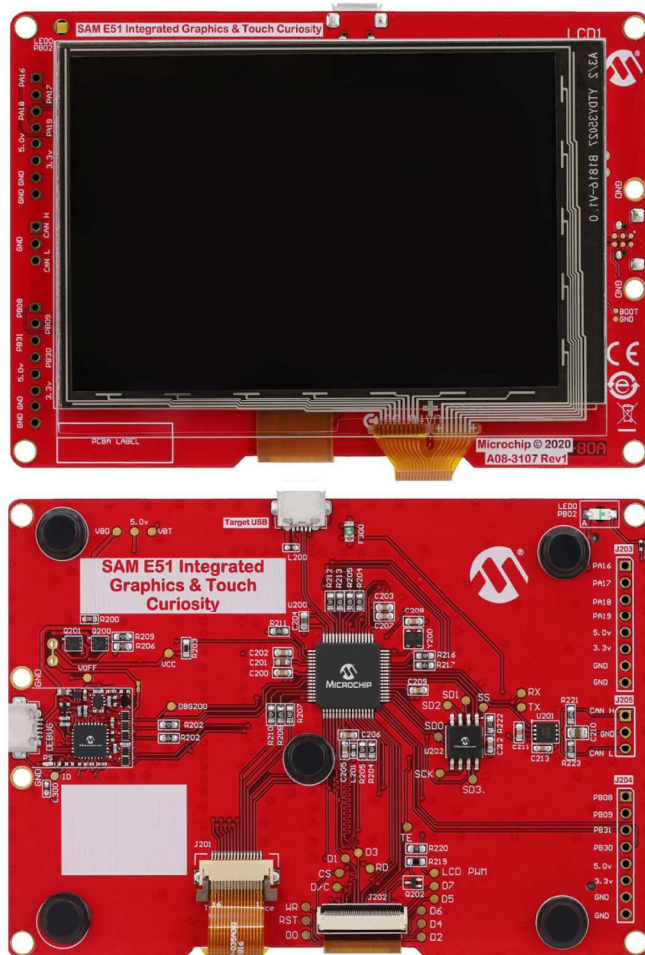

---

## Table of Contents

---

Preface.....	1
1. Introduction.....	3
1.1. Features.....	3
1.2. Kit Overview.....	3
2. Getting Started.....	4
2.1. Quick Start.....	4
3. On-Board Debugger.....	5
3.1. Virtual COM Port.....	5
3.2. Power Supply.....	6
4. Hardware.....	8
5. Hardware Revision History.....	10
5.1. Identifying Product ID and Revision.....	10
6. Schematics.....	11
7. LCD and Touch Screen Overlay.....	19
8. Revision History.....	21
The Microchip Website.....	22
Product Change Notification Service.....	22
Customer Support.....	22
Microchip Devices Code Protection Feature.....	22
Legal Notice.....	23
Trademarks.....	23
Quality Management System.....	24
Worldwide Sales and Service.....	25

## 1. Introduction

### 1.1 Features

The following are key features of the evaluation kit.

- ATSAME51J20A microcontroller
- One user LED
- On-board debugger
  - Board identification in MPLAB X IDE
  - One green power LED and status LED
  - Programming and debugging
  - Virtual COM port (CDC)
  - One Logic Analyzer (DGI GPIO)
- 8 MB QSPI Flash
- On-board CAN-FD transceiver
- USB powered
- Adjustable target voltage:
  - MIC5353 LDO regulator controlled by the on-board debugger
  - 1.7-3.6V output voltage
- 500 mA maximum output current (limited by ambient temperature and output voltage)
- 480 x 320 pixel TFT display with 16-bit color

### 1.2 Kit Overview

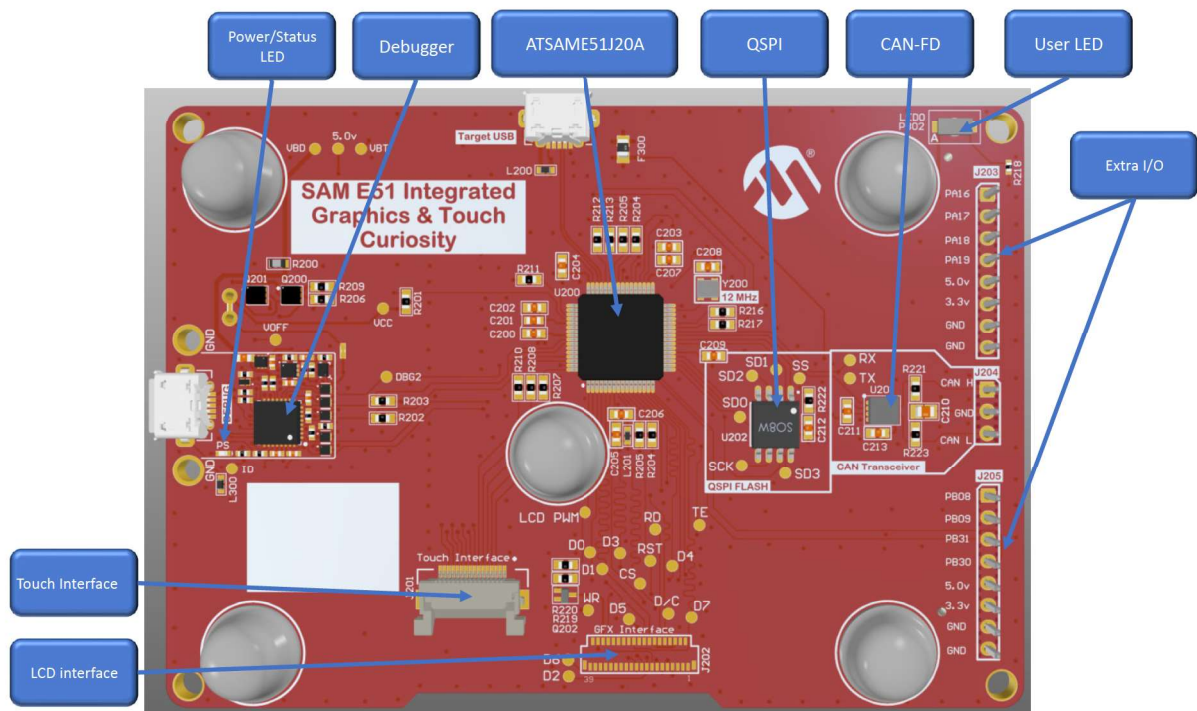

## **2. Getting Started**

### **2.1 Quick Start**

Follow these steps to exploring the platform:

1. Download MPLAB X IDE.
2. Launch MPLAB X IDE.
3. Connect a USB cable (Standard-A to Micro-B or Micro-AB) between the PC and the debug USB port on the kit.

When the Curiosity kit is connected to the computer for the first time, the operating system will perform a driver software installation. The driver file supports both 32-bit and 64-bit versions of Microsoft® Windows® XP, Windows Vista®, Windows 7, Windows 8, and Windows 10. The drivers for the evaluation kit are included with MPLAB X IDE.

After the Curiosity board is powered, the green status LED will be lit and MPLAB X IDE will auto-detect which Curiosity board is connected. MPLAB X IDE will present relevant information, such as data sheets and kit documentation. The SAME51J20A device is programmed and debugged by the on-board debugger, therefore no external programmer or debugger tool is required.

### 3. On-Board Debugger

The SAM E51 Integrated Graphics and Touch Curiosity Board contains an on-board debugger for programming and debugging. The on-board debugger is a composite USB device of several interfaces: a debugger, a data gateway, and a Virtual COM port. Together with MPLAB X IDE, the on-board debugger interface can program and debug the SAME51J20A. A Data Gateway Interface (DGI) is available for use with the logic analyzer channels for code instrumentation, to visualize program flow. DGI GPIOs can be graphed using the Data Visualizer.

The Virtual COM port is connected to a UART on the SAME51J20A providing an easy way to communicate with the target application through terminal software. The on-board debugger controls one Power and Status LED (marked PS) on the SAM E51 Integrated Graphics and Touch Curiosity board. The following table shows how the LED is controlled in different operation modes.

**Table 3-1. On-Board Debugger LED Control**

Operation Mode	Status LED
Boot Loader mode	LED blink at 1 Hz during power up.
Power-up	LED is lit - constant.
Normal operation	LED is lit - constant.
Programming	Activity indicator; the LED flashes slowly during programming or debugging.
Fault	The LED flashes fast if a power fault is detected.
Sleep/Off	LED is off. The on-board debugger is either in Sleep mode or powered down. This can occur if the kit is externally powered.

#### 3.1 Virtual COM Port

A general-purpose USB serial bridge between a Host PC and a target device.

##### 3.1.1 Overview

The debugger implements a composite USB device that includes a standard Communications Device Class (CDC) interface, which appears on the Host as a Virtual COM Port. The CDC can be used to stream arbitrary data in both directions between the Host and the target: characters sent from the Host will appear in UART form on the CDC TX pin, and UART characters sent into the CDC RX pin will be sent back to the Host. On Windows machines, the CDC will enumerate as Curiosity Virtual COM Port and appear in the ports section of the device manager.



**Important:** On older Windows systems, a USB driver is required for the CDC. This driver is included in Atmel® Studio and MPLAB X IDE installations. On Linux machines, the CDC will enumerate and appear as `/dev/ttyACM#`. On MAC machines, the CDC will enumerate and appear as `/dev/tty.usbmodem#`. Depending on which terminal program is used, it will appear in the available list of modems as `usbmodem#`.

##### 3.1.2 Limitations

Not all UART features are implemented in the debugger CDC; the constraints are as follows:

- Baud rate – Must be in the range of 1200 bps to 500 kbps, and values outside this range will be capped to these values, without warning. Baud rate can be changed on-the-fly.
- Character format – Only 8-bit characters are supported.
- Parity – Can be odd, even, or none.
- Hardware flow control – Not supported.
- Stop bits – One or two bits are supported.

### 3.1.3 Signaling

During USB enumeration, the Host OS will start both communication and data pipes of the CDC interface. At this point, it is possible to set and read back baud rate and other UART parameters of the CDC, but data sending and receiving will not be enabled. When a terminal connects on the Host, it must assert the DTR signal. This is a virtual control signal that is implemented on the USB interface but not in the hardware of the debugger.

Asserting DTR from the Host will indicate to the debugger that a CDC session is active, and it will enable its level shifters (if available), and start the CDC data send and receive mechanisms. De-asserting the DTR signal will not disable the level shifters, but it will disable the receiver, hence no further data will be streamed to the Host. Data packets that are already queued up for sending to the target will continue to be sent out, but no further data will be accepted.

### 3.1.4 Advanced Use

In CDC Override mode for normal operation, the on-board debugger is a true UART bridge between the Host and the device. However, under certain use cases, the debugger can override the Basic Operating mode and use the CDC pins for other purposes. Dropping a text file (with extension .txt) into the debugger's mass storage drive can be used to send characters out of the CDC TX pin. The text file must start with the characters, `CMD: SEND_UART=`. The maximum message length is 50 characters, and all remaining data in the frame is ignored. The default baud rate used in this mode is 9600 bps, but if the CDC is already active or configured, the last used baud rate still applies.

#### USB-Level Framing Considerations:

Sending data from the Host to the CDC can be done byte-wise or in blocks, which will be chunked into 64-byte USB frames. Each frame will be queued up for sending to the CDC TX pin. Sending a small amount of data per frame can be inefficient, particularly at low baud rates, because the debugger buffers frames, not bytes. A maximum of 4 x 64-byte frames can be active at any time, the debugger will throttle the incoming frames accordingly. Sending full 64-byte frames containing data is the most efficient.

When receiving data from the target, the debugger will queue incoming bytes into 64-byte frames, which are sent to the USB queue for transmission to the Host when they are full. Incomplete frames are also pushed to the USB queue at approximately 100 ms intervals, triggered by USB start-of-frame tokens. Up to 8 x 64-byte frames can be active at any time. If the Host or software fails to receive data fast enough, an overrun will occur. When this happens, the last-filled buffer frame will be recycled instead of being sent to the USB queue, and a full frame of data will be lost. To prevent this occurrence, the user must ensure that the CDC data pipe is being read continuously, or the incoming data rate must be reduced.

## 3.2 Power Supply

The kit is powered through the USB port and contains two regulators for generating 3.3V for the debugger and an adjustable regulator for the target. The voltage from the USB connector can vary between 4.4V to 5.25V according to the USB specification, and will limit the maximum voltage to the target. The following figure shows the entire power supply system on the SAM E51 Integrated Graphics and Touch Curiosity Board.

**Figure 3-1. Power Supply Block Diagram**

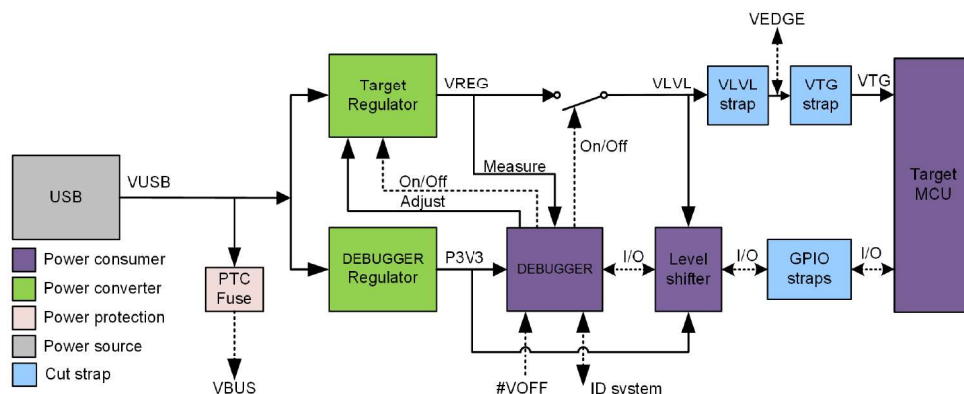

### 3.2.1 Target Regulator

The target voltage regulator is a MIC5353 variable output LDO. The on-board debugger can adjust the voltage output that is supplied to the kit target section by manipulating the feedback voltage of the MIC5353. The hardware implementation is limited to an approximate voltage range from 1.7V to 5.1V. Additional output voltage limits are configured in the debugger firmware to ensure that the output voltage never exceeds the hardware limits of the SAME51J20A microcontroller. The voltage limits configured in the on-board debugger on the SAM E51 Integrated Graphics and Touch Curiosity are 1.7V to 3.6V. The target voltage is set to 3.3V in production and can be changed through MPLAB X IDE. Any change to the target voltage done in MPLAB X IDE is persistent, even through a power toggle.

The MIC5353 supports a maximum current load of 500 mA. It is an LDO regulator in a small package, placed on a small PCB, and the thermal shutdown condition can be reached at lower loads than 500 mA. The maximum current load depends on the input voltage, set output voltage, and the ambient temperature. The following figure shows the safe operation area for the regulator, with an input voltage of 5.1V and an ambient temperature of 23°C.

**Figure 3-2. Target Regulator Safe Operation Area**

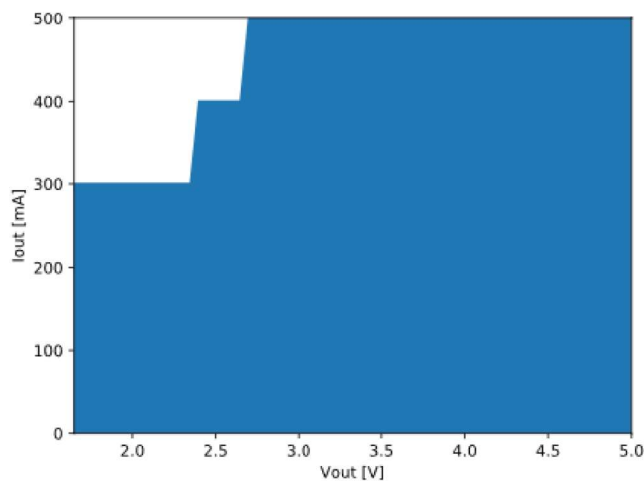

### 3.2.2 External Supply

The SAME51J20A Curiosity can be powered by an external voltage instead of the on-board target regulator. When the Voltage Off (VOFF) pin is shorted to ground (GND), the on-board debugger firmware disables the target regulator and it is safe to apply an external voltage to the VTG pin.



**WARNING** Applying an external voltage to the VTG pin without shorting VOFF to GND may cause permanent damage to the kit.



**WARNING** Absolute maximum external voltage is 5.5V for the level shifters on board. Applying a higher voltage may cause permanent damage to the kit.

Programming, debugging, and data streaming is still possible while using external power, as the debugger and signal level shifters will be powered from the USB cable. Both regulators, the debugger, and the level shifters are powered down when the USB cable is removed.

## 4. Hardware

The system block diagram is shown below.

Figure 4-1. System Block Diagram

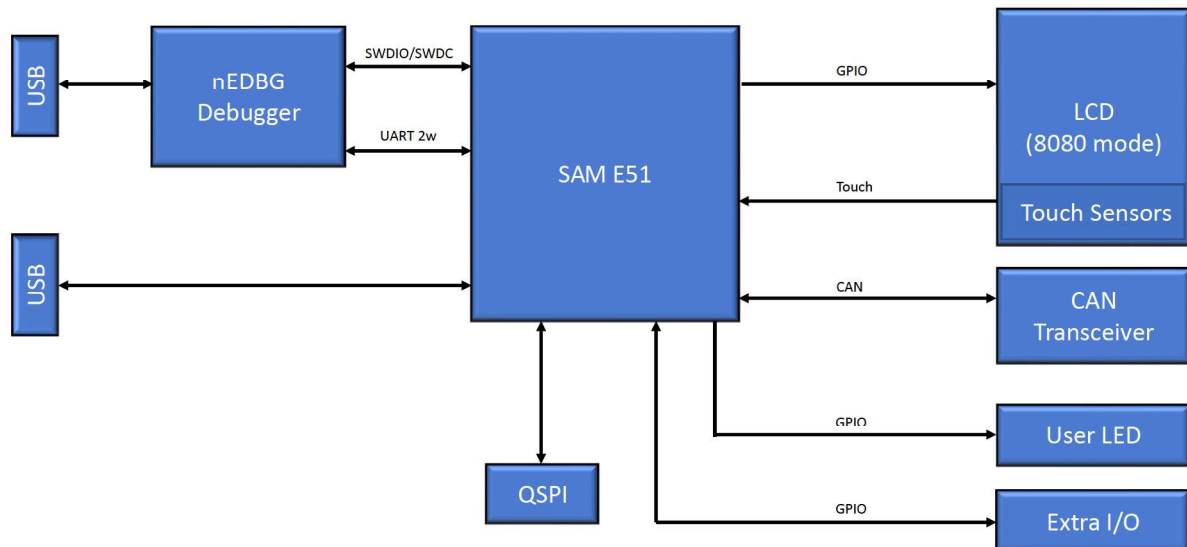

Table 4-1. User Programmable LED

Pin	Port	Function	Other
63	PB02	User LED	Active Low

Table 4-2. Virtual CDC COM Port

Pin	Port	Function	Description
29	PA12	SERCOM2/PAD0	TX from MCU to Debugger
30	PA13	SERCOM2/PAD1	RX to MCU From Debugger

Table 4-3. CAN-FD Interface

Pin	Port	Function
25	PB12	CAN1 TX
26	PB13	CAN1 RX

**Note:** This board has a CAN-FD interface and an on-board transceiver. The transceiver output is available on J204.

Table 4-4. Extra Ports

Pin	Port	Function				
35	PA16	SERCOM1/PAD0	SERCOM3/PAD1	TC2/WO[0]	TCC1/WO[0]	PTC[X10/Y10]
36	PA17	SERCOM1/PAD1	SERCOM3/PAD0	TC2/WO[1]	TCC1/WO[1]	PTC[X11/Y11]
37	PA18	SERCOM1/PAD2	SERCOM3/PAD2	TC3/WO[0]	TCC1/WO[2]	PTC[X12/Y12]
38	PA19	SERCOM1/PAD3	SERCOM3/PAD3	TC3/WO[1]	TCC1/WO[3]	PTC[X13/Y13]
11	PB08	SERCOM4/PAD0	ADC0/AIN[2]	ADC1/AIN[0]	–	PTC[X1/Y1]



# EV14C17A

## Hardware

.....continued

Pin	Port	Function				
12	PB09	SERCOM4/PAD1	ADC0/AIN[1]	ADC1/AIN[1]	TC4/WO[1]	PTC[X2/Y2]
60	PB31	SERCOM5/PAD0	SERCOM7/PAD1	TC0\WO[1]	TCC4/WO[1]	
59	PB30	SERCOM5/PAD1	SERCOM7/PAD0	TC0\WO[0]	TCC4/WO[0]	

**Notes:**

1. Extra I/O is available on a header that can be used for user defined functions.
2. For additional information on peripherals and pins, refer to the data sheet.

## **5. Hardware Revision History**

This user guide provides the latest available revision of the kit. This chapter contains information about known issues, a revision history, and how older revisions differ from the latest revision.

### **5.1 Identifying Product ID and Revision**

The revision and product identifier of the SAM E51 Integrated Graphics and Touch Curiosity Boards can be found in two ways: either through MPLAB X IDE or by looking at the sticker on the bottom of the PCB. By connecting a Curiosity board to a computer with MPLAB X IDE running, an information window will pop up. The first six digits of the serial number, which is listed under kit details, contains the product identifier and revision. The same information can be found on the sticker on the bottom of the PCB. Most kits will print the identifier and revision in plain text as A09-nnnn\rr, where nnnn is the identifier and rr is the revision. Boards with limited space have a sticker with only a QR-code, which contains a serial number string. The serial number string has the following format:

"nnnnrrssssssss"

n = product identifier

r = revision

s = serial number

6. Schematics

SAM E51 Integrated Graphics & Touch Curiosity

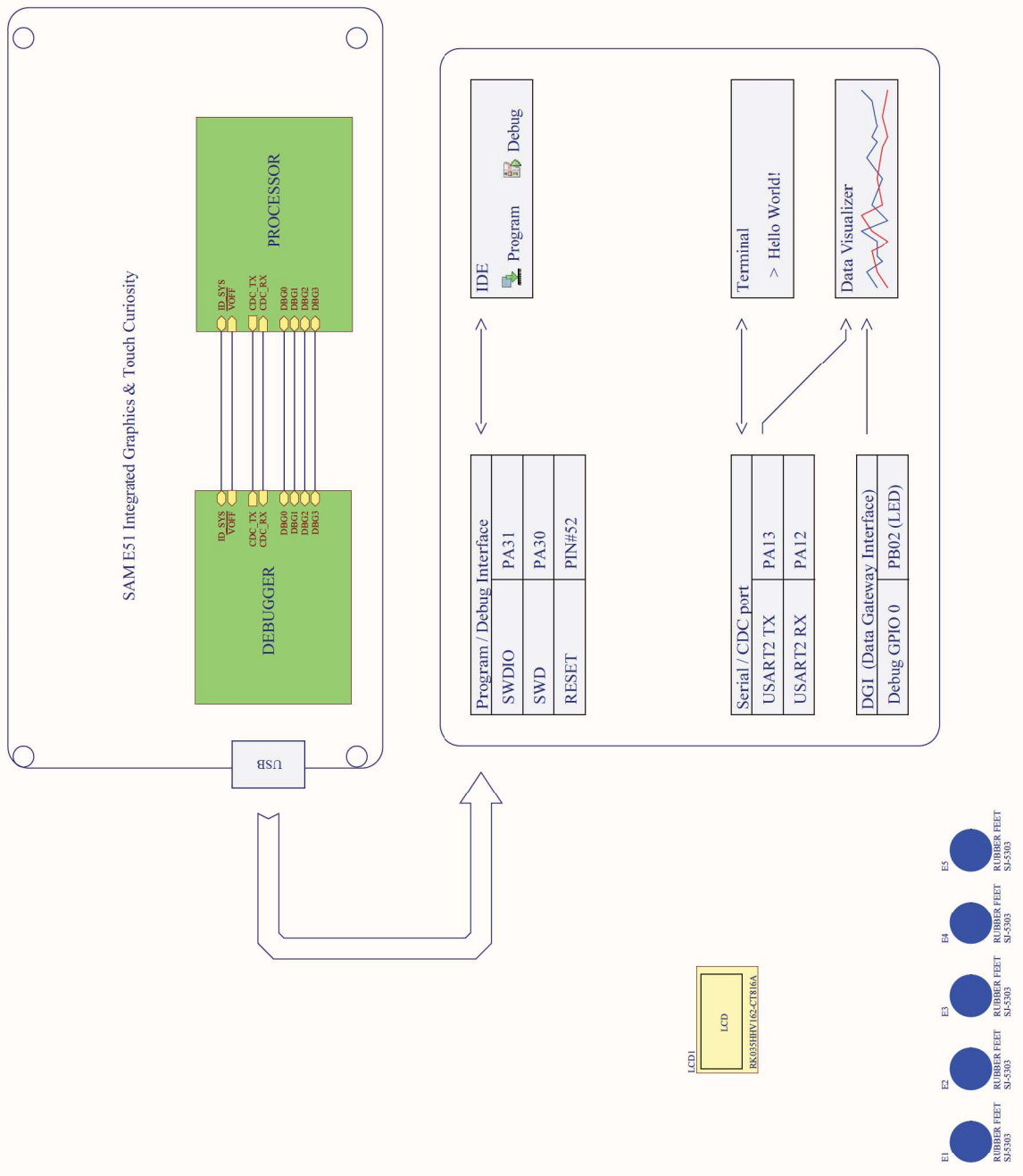



Interface	SWD	TARGET
Signal	CDC TX	UART TX
	CDC RX	UART TX
	DBG0	SWDAT
	DBG1	SWCLK
	DBG2	GPO
	DBG3	RESET
	VCC	-

**J300:**

- Cut-strap used for full separation of target power from the level shifters and on-board regulators.
- For current measurements using the on-board power supply, this strap must be cut and an alternative connector used.

**J301:**

- For current measurements using the on-board power supply, this strap must be cut and an alternative connector used.

**MIC5208:**

- Vin: 2.5V to 5.5V
- Vout: Fixed 3.3V
- Iout: 500mA
- Dropout: 20mV @ 500mA

**MIC5208:**

- Vin: 2.5V to 5.5V
- Vout: Fixed 3.3V
- Iout: 500mA
- Dropout: 20mV @ 500mA

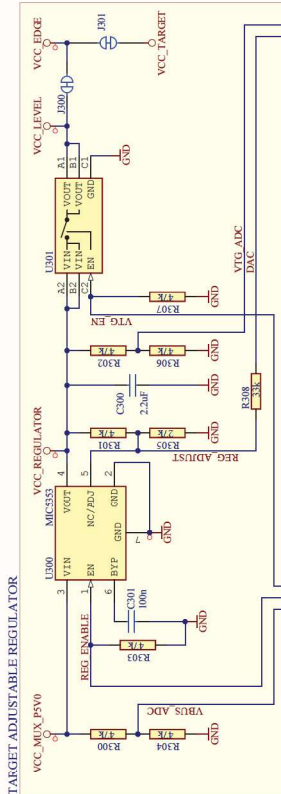

**Adjustable output and limitations:**

- The DEBUGGER can adjust the output voltage of the regulator between 1.25V and 5.1V to the target.
- The level shifters have a minimal voltage level of 1.65V and will limit the minimum operating voltage allowed for the target to still allow communication.
- The MIC5208 has a minimal voltage level of 1.70V and will limit the minimum voltage delivered to the target.
- Firmware configuration will limit the voltage range to be within the target specification.

**DEBUGGER TESTPOINT**

SWCLK

SWDIO

TP401

TP402

TP403

TP404

TP405

TP406

TP407

TP408

TP409

TP410

TP411

TP412

TP413

TP414

TP415

TP416

TP417

TP418

TP419

TP420

TP421

TP422

TP423

TP424

TP425

TP426

TP427

TP428

TP429

TP430

TP431

TP432

TP433

TP434

TP435

TP436

TP437

TP438

TP439

TP440

TP441

TP442

TP443

TP444

TP445

TP446

TP447

TP448

TP449

TP450

TP451

TP452

TP453

TP454

TP455

TP456

TP457

TP458

TP459

TP460

TP461

TP462

TP463

TP464

TP465

TP466

TP467

TP468

TP469

TP470

TP471

TP472

TP473

TP474

TP475

TP476

TP477

TP478

TP479

TP480

TP481

TP482

TP483

TP484

TP485

TP486

TP487

TP488

TP489

TP490

TP491

TP492

TP493

TP494

TP495

TP496

TP497

TP498

TP499

TP500

# DEBUGGER

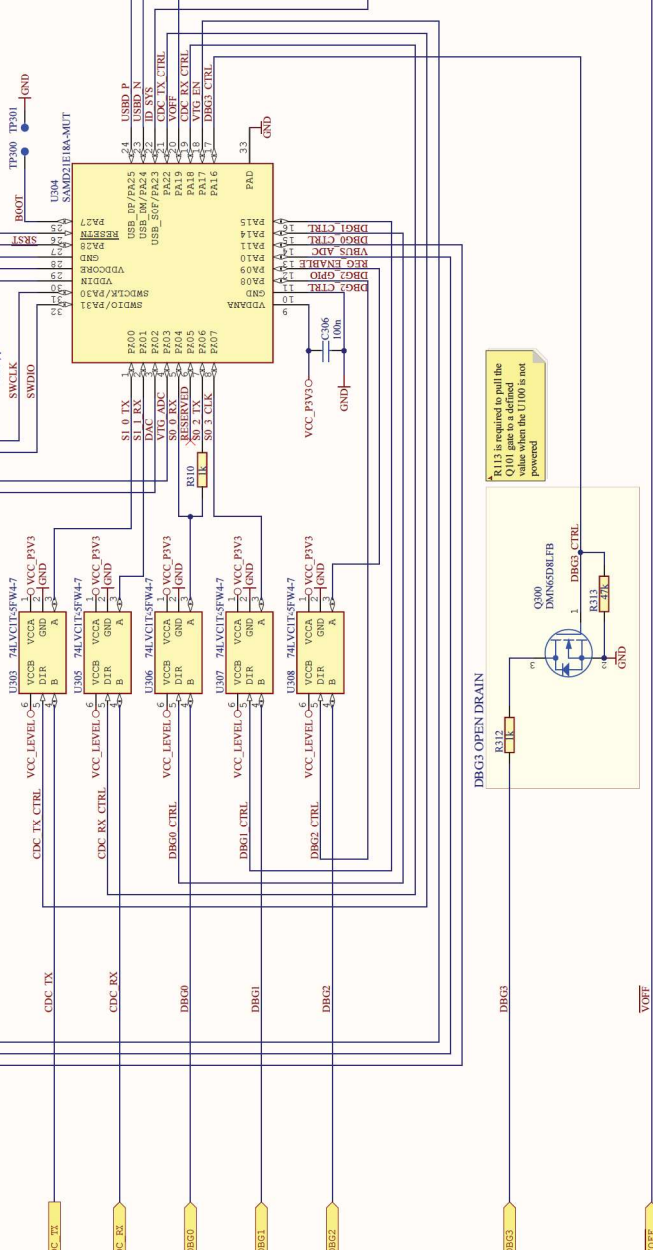
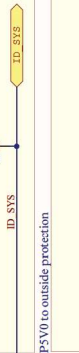
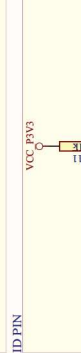
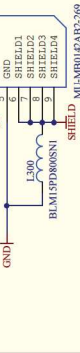
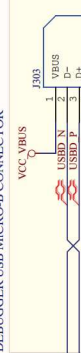
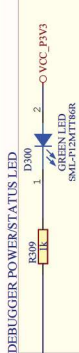

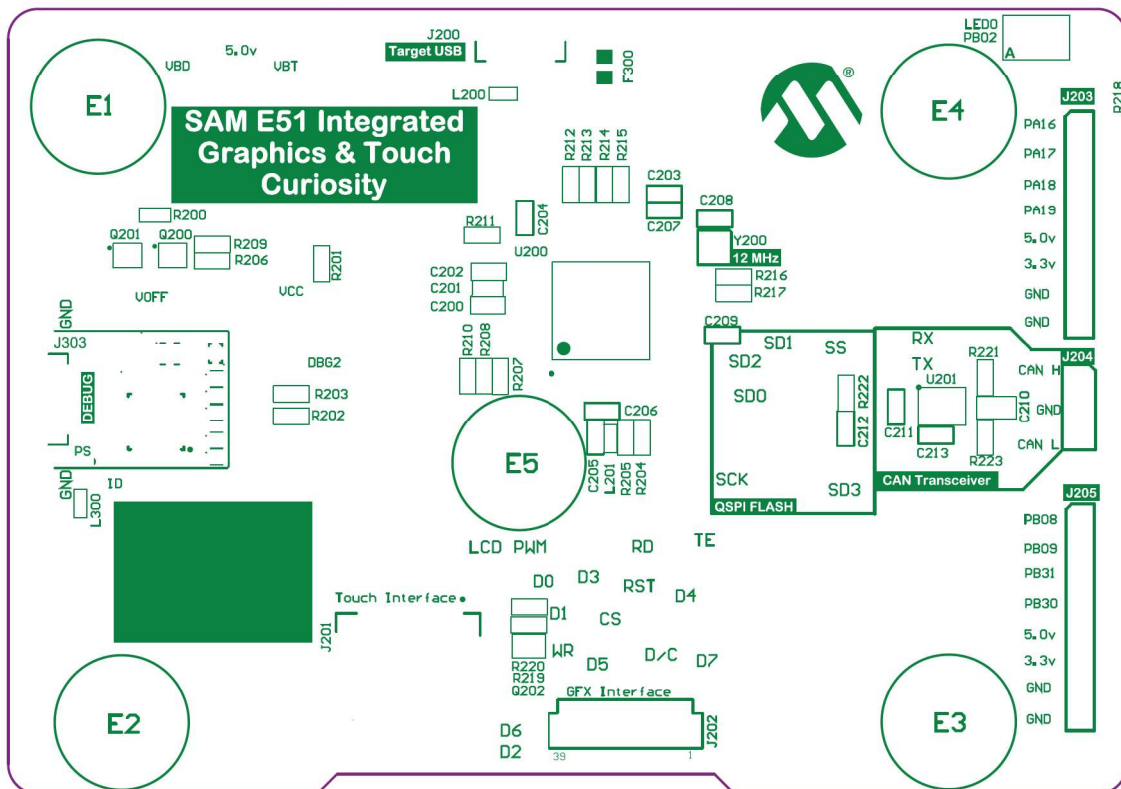
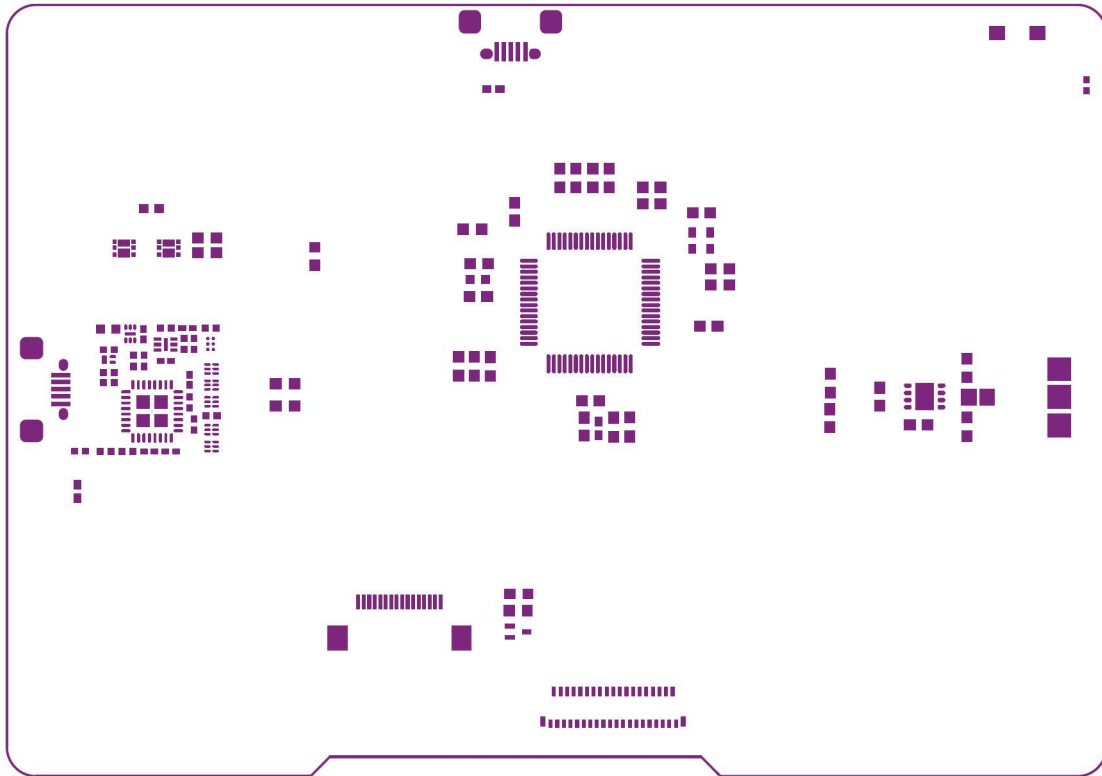

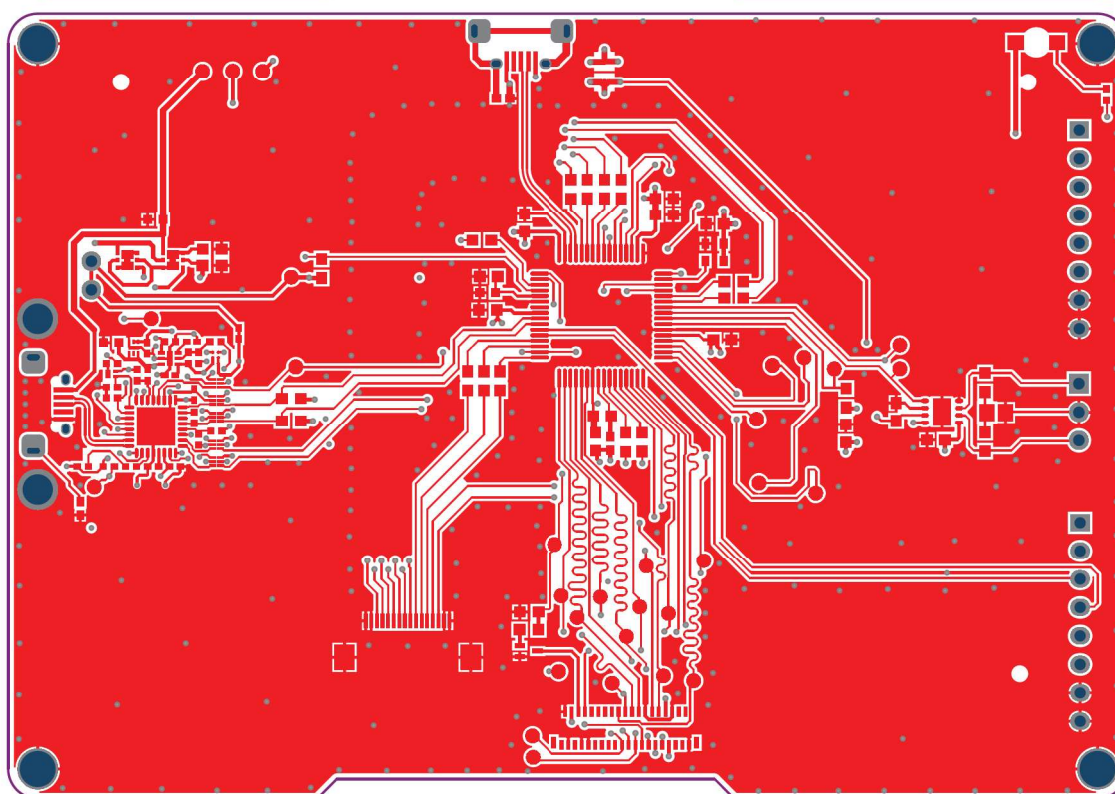
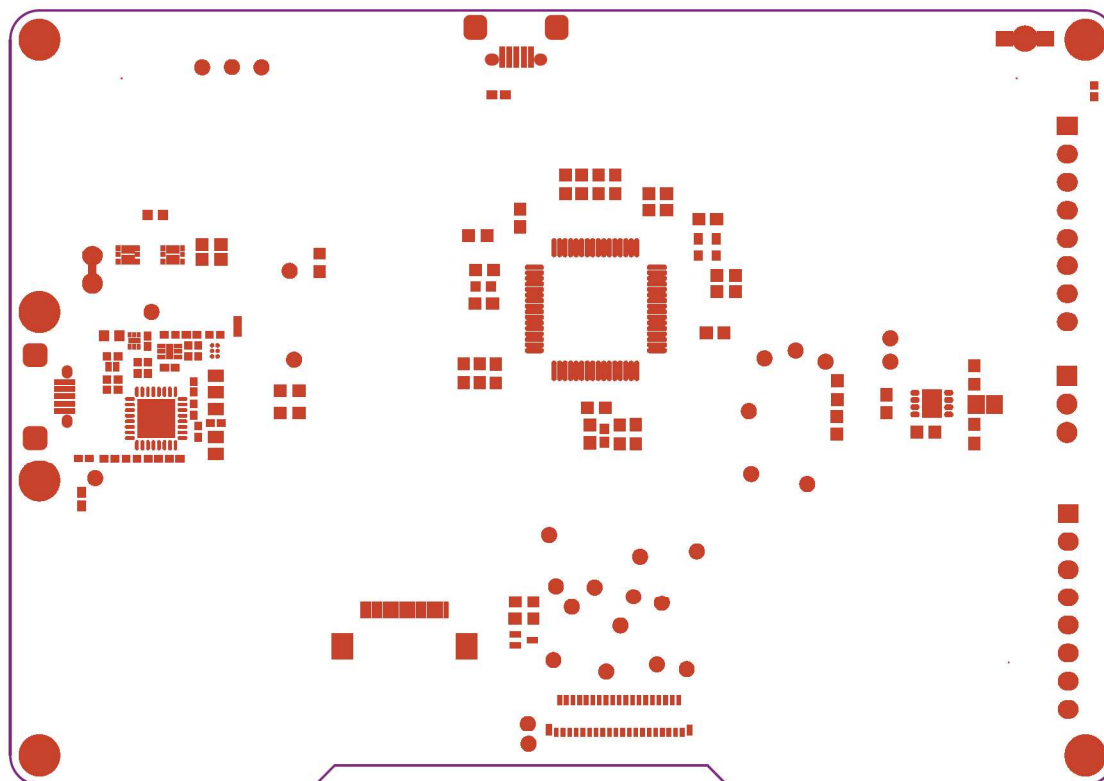

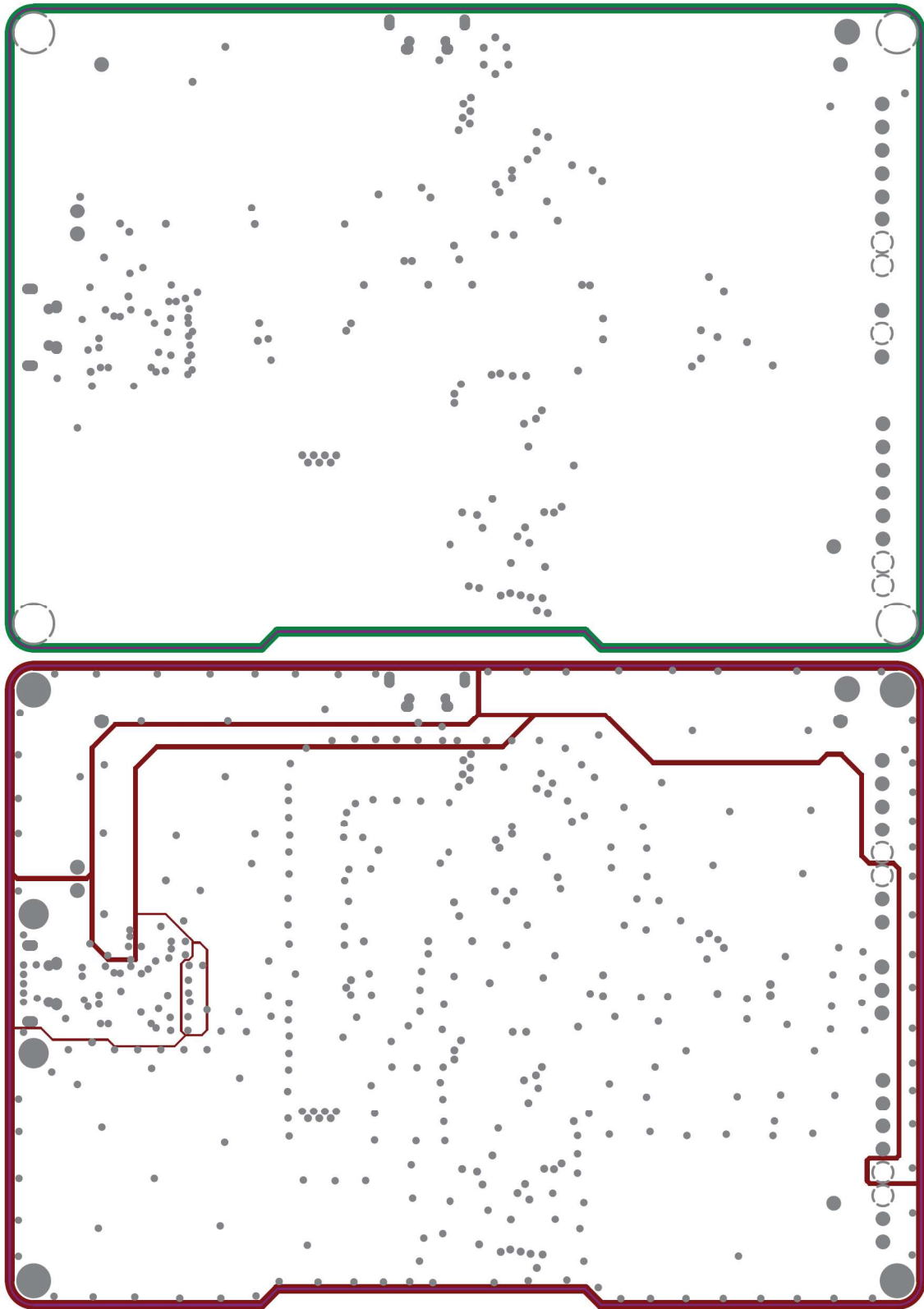



# EV14C17A

## Schematics

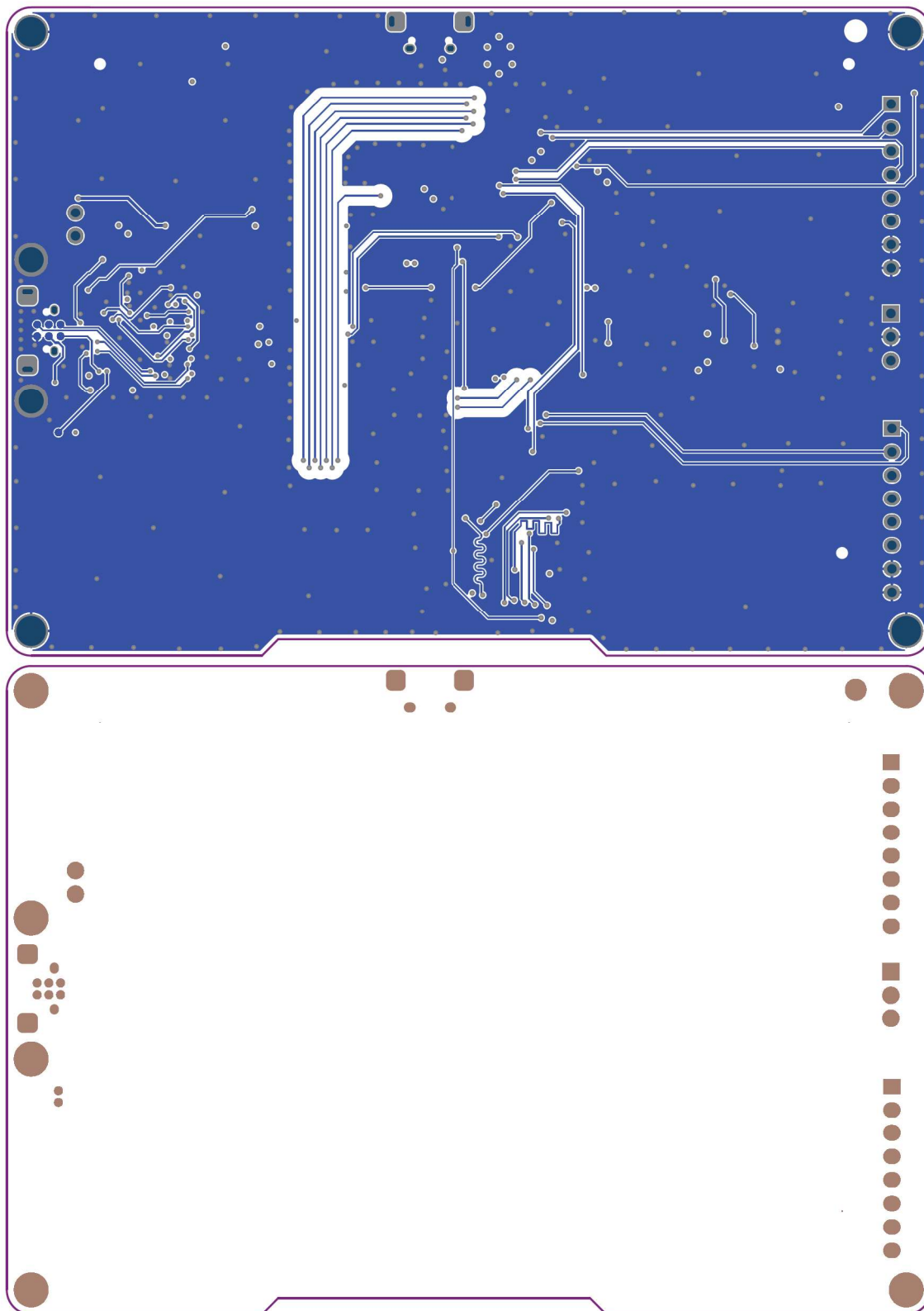

# EV14C17A

## Schematics

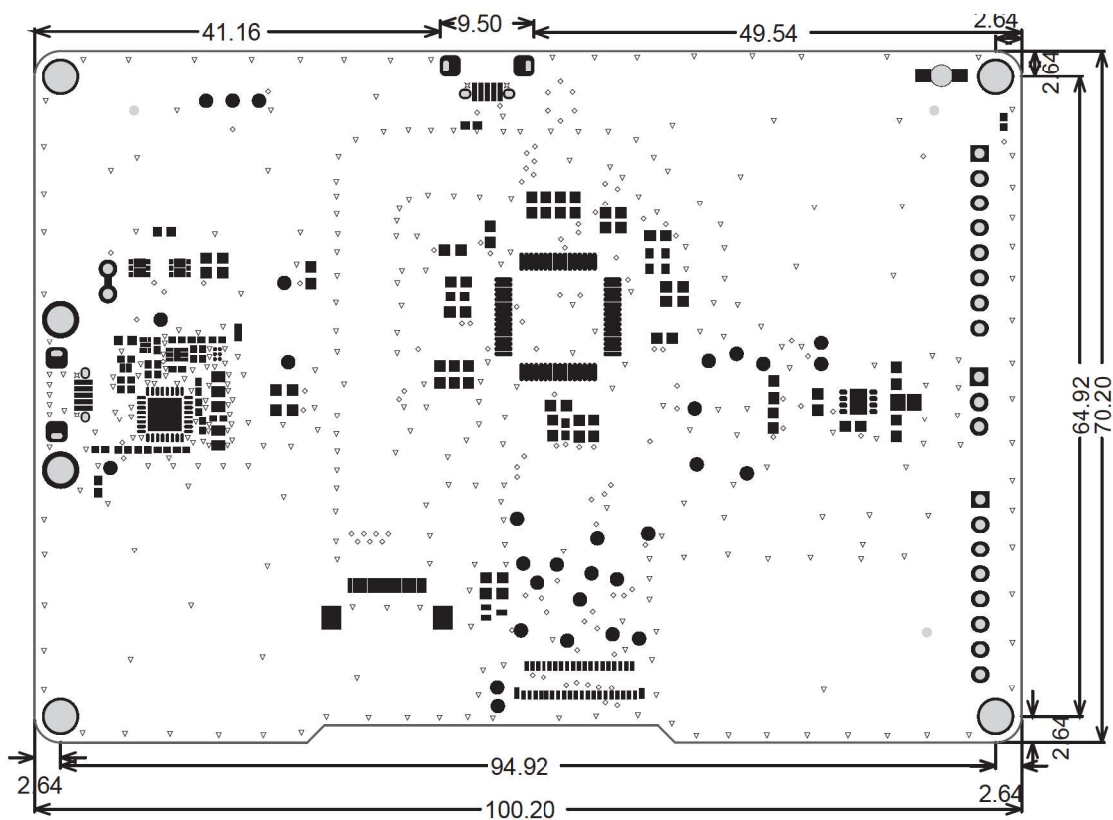
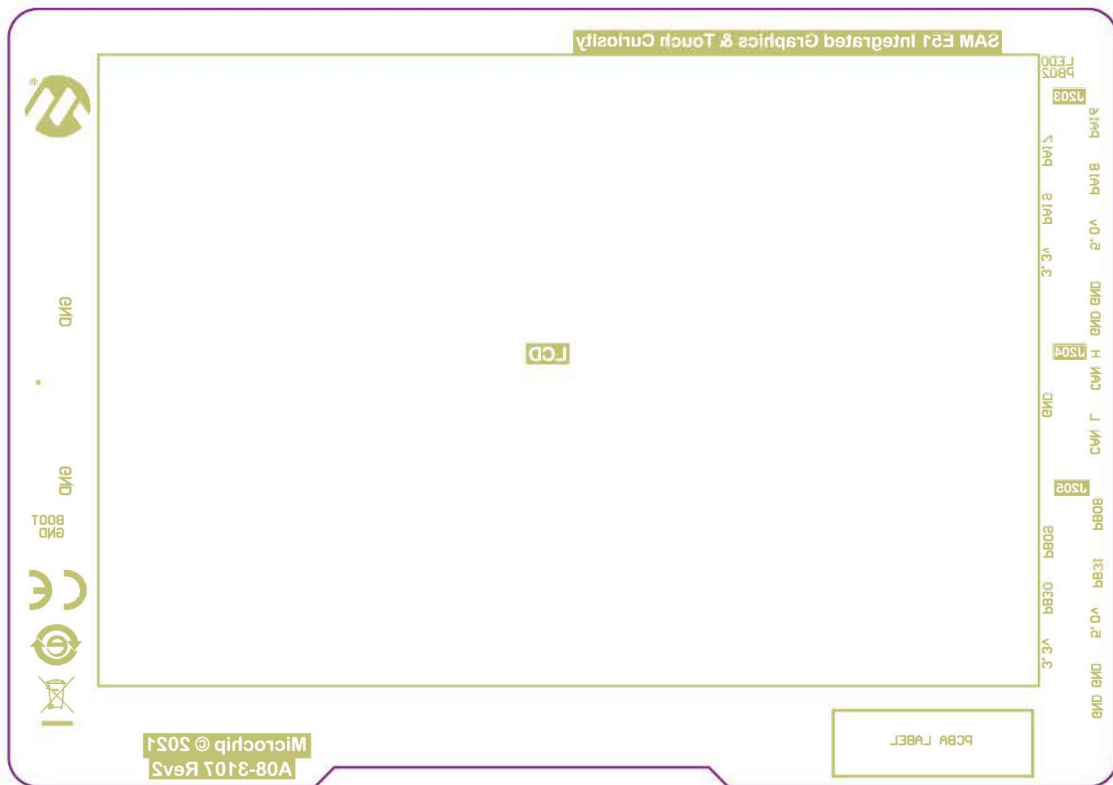

## 7. LCD and Touch Screen Overlay

The demonstration kit comes with a 3.5 inch TFT + CTP display attached. Displays, RK035HHV162-CT675A, can be directly purchased from ROCKTECH®.

The following images are used with permission from ROCKTECH® Displays Limited for describing the LCD and Touchscreen Overlay used on the SAM E51 Integrated Graphics and Touch Curiosity Board. For further information, contact a local Microchip or ROCKTECH® Sales representative.

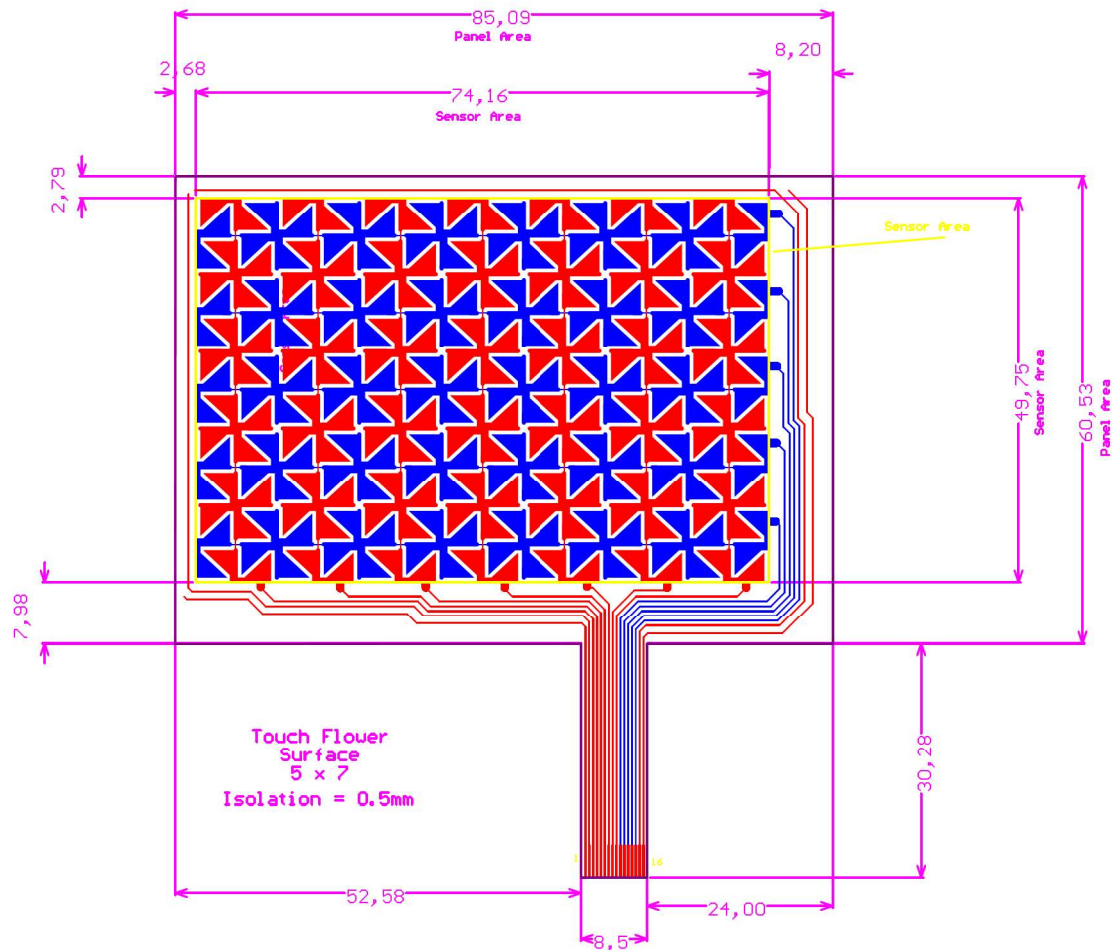

# EV14C17A

## LCD and Touch Screen Overlay

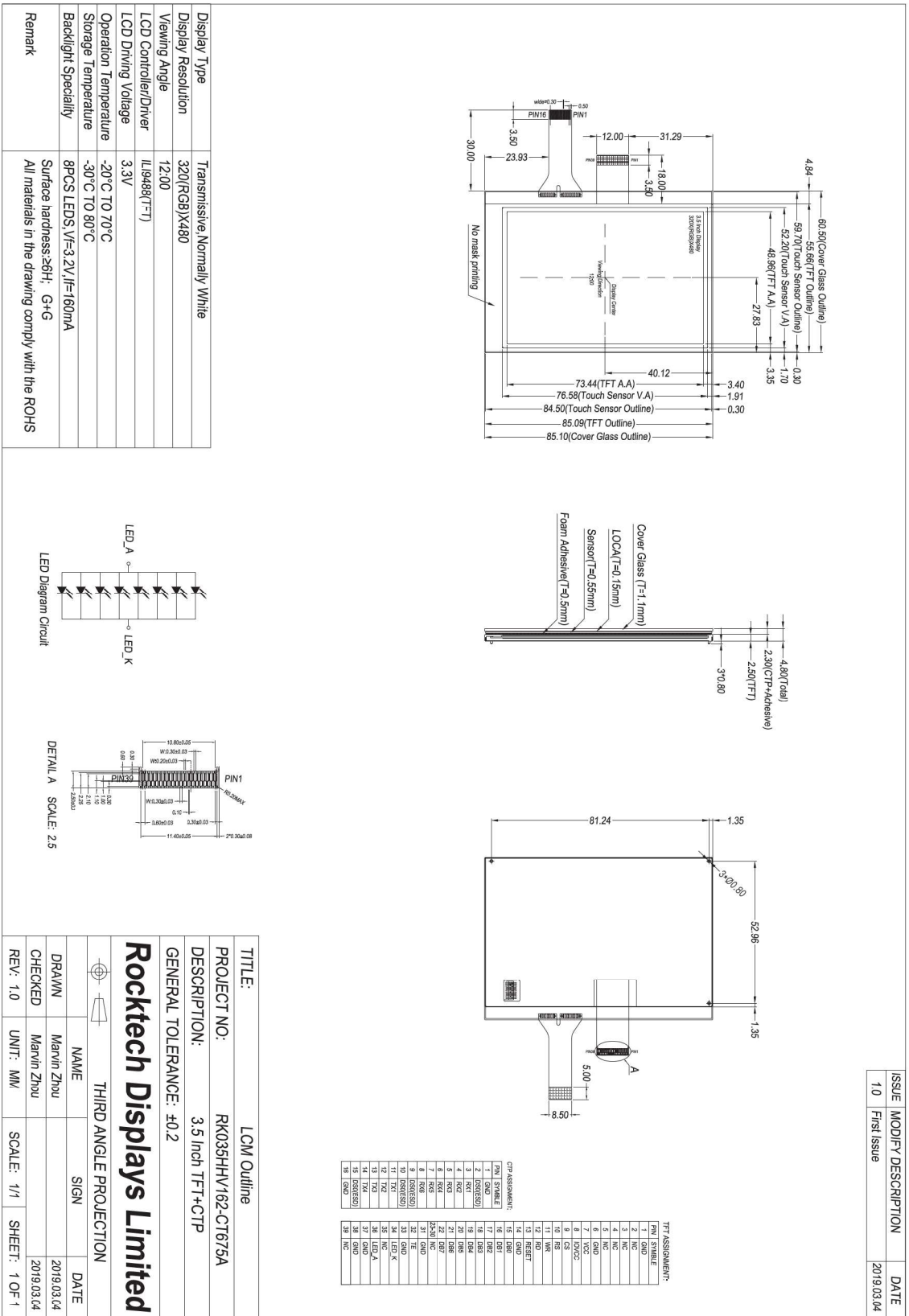

## **8. Revision History**

### **Revision A - May 2021**

This is the initial released version of this document.

Terminology used in this document may not match with the contents of the current revision of the device data sheet or other Microchip documentation and collateral. If there are any questions or concerns regarding terminology, contact a Microchip support or sales representative.

---

## The Microchip Website

---

Microchip provides online support via our website at [www.microchip.com/](http://www.microchip.com/). This website is used to make files and information easily available to customers. Some of the content available includes:

- **Product Support** – Data sheets and errata, application notes and sample programs, design resources, user's guides and hardware support documents, latest software releases and archived software
- **General Technical Support** – Frequently Asked Questions (FAQs), technical support requests, online discussion groups, Microchip design partner program member listing
- **Business of Microchip** – Product selector and ordering guides, latest Microchip press releases, listing of seminars and events, listings of Microchip sales offices, distributors and factory representatives

---

## Product Change Notification Service

---

Microchip's product change notification service helps keep customers current on Microchip products. Subscribers will receive email notification whenever there are changes, updates, revisions or errata related to a specified product family or development tool of interest.

To register, go to [www.microchip.com/pcn](http://www.microchip.com/pcn) and follow the registration instructions.

---

## Customer Support

---

Users of Microchip products can receive assistance through several channels:

- Distributor or Representative
- Local Sales Office
- Embedded Solutions Engineer (ESE)
- Technical Support

Customers should contact their distributor, representative or ESE for support. Local sales offices are also available to help customers. A listing of sales offices and locations is included in this document.

Technical support is available through the website at: [www.microchip.com/support](http://www.microchip.com/support)

---

## Microchip Devices Code Protection Feature

---

Note the following details of the code protection feature on Microchip devices:

- Microchip products meet the specifications contained in their particular Microchip Data Sheet.
- Microchip believes that its family of products is secure when used in the intended manner and under normal conditions.
- There are dishonest and possibly illegal methods being used in attempts to breach the code protection features of the Microchip devices. We believe that these methods require using the Microchip products in a manner outside the operating specifications contained in Microchip's Data Sheets. Attempts to breach these code protection features, most likely, cannot be accomplished without violating Microchip's intellectual property rights.
- Microchip is willing to work with any customer who is concerned about the integrity of its code.
- Neither Microchip nor any other semiconductor manufacturer can guarantee the security of its code. Code protection does not mean that we are guaranteeing the product is "unbreakable." Code protection is constantly evolving. We at Microchip are committed to continuously improving the code protection features of our products. Attempts to break Microchip's code protection feature may be a violation of the Digital Millennium Copyright Act. If such acts allow unauthorized access to your software or other copyrighted work, you may have a right to sue for relief under that Act.

---

## Legal Notice

---

Information contained in this publication is provided for the sole purpose of designing with and using Microchip products. Information regarding device applications and the like is provided only for your convenience and may be superseded by updates. It is your responsibility to ensure that your application meets with your specifications.

THIS INFORMATION IS PROVIDED BY MICROCHIP "AS IS". MICROCHIP MAKES NO REPRESENTATIONS OR WARRANTIES OF ANY KIND WHETHER EXPRESS OR IMPLIED, WRITTEN OR ORAL, STATUTORY OR OTHERWISE, RELATED TO THE INFORMATION INCLUDING BUT NOT LIMITED TO ANY IMPLIED WARRANTIES OF NON-INFRINGEMENT, MERCHANTABILITY, AND FITNESS FOR A PARTICULAR PURPOSE OR WARRANTIES RELATED TO ITS CONDITION, QUALITY, OR PERFORMANCE.

IN NO EVENT WILL MICROCHIP BE LIABLE FOR ANY INDIRECT, SPECIAL, PUNITIVE, INCIDENTAL OR CONSEQUENTIAL LOSS, DAMAGE, COST OR EXPENSE OF ANY KIND WHATSOEVER RELATED TO THE INFORMATION OR ITS USE, HOWEVER CAUSED, EVEN IF MICROCHIP HAS BEEN ADVISED OF THE POSSIBILITY OR THE DAMAGES ARE FORESEEABLE. TO THE FULLEST EXTENT ALLOWED BY LAW, MICROCHIP'S TOTAL LIABILITY ON ALL CLAIMS IN ANY WAY RELATED TO THE INFORMATION OR ITS USE WILL NOT EXCEED THE AMOUNT OF FEES, IF ANY, THAT YOU HAVE PAID DIRECTLY TO MICROCHIP FOR THE INFORMATION. Use of Microchip devices in life support and/or safety applications is entirely at the buyer's risk, and the buyer agrees to defend, indemnify and hold harmless Microchip from any and all damages, claims, suits, or expenses resulting from such use. No licenses are conveyed, implicitly or otherwise, under any Microchip intellectual property rights unless otherwise stated.

---

## Trademarks

---

The Microchip name and logo, the Microchip logo, Adaptec, AnyRate, AVR, AVR logo, AVR Freaks, BesTime, BitCloud, chipKIT, chipKIT logo, CryptoMemory, CryptoRF, dsPIC, FlashFlex, flexPWR, HELDO, IGLoo, JukeBlox, KeeLoq, KleeR, LANCheck, LinkMD, maXStylus, maXTouch, MediaLB, megaAVR, Microsemi, Microsemi logo, MOST, MOST logo, MPLAB, OptoLyzer, PackeTime, PIC, picoPower, PICSTART, PIC32 logo, PolarFire, Prochip Designer, QTouch, SAM-BA, SenGenuity, SpyNIC, SST, SST Logo, SuperFlash, Symmetricom, SyncServer, Tachyon, TimeSource, tinyAVR, UNI/O, Vectron, and XMEGA are registered trademarks of Microchip Technology Incorporated in the U.S.A. and other countries.

AgileSwitch, APT, ClockWorks, The Embedded Control Solutions Company, EtherSynch, FlashTec, Hyper Speed Control, HyperLight Load, IntelliMOS, Libero, motorBench, mTouch, Powermite 3, Precision Edge, ProASIC, ProASIC Plus, ProASIC Plus logo, Quiet-Wire, SmartFusion, SyncWorld, Temux, TimeCesium, TimeHub, TimePictra, TimeProvider, WinPath, and ZL are registered trademarks of Microchip Technology Incorporated in the U.S.A.

Adjacent Key Suppression, AKS, Analog-for-the-Digital Age, Any Capacitor, AnyIn, AnyOut, Augmented Switching, BlueSky, BodyCom, CodeGuard, CryptoAuthentication, CryptoAutomotive, CryptoCompanion, CryptoController, dsPICDEM, dsPICDEM.net, Dynamic Average Matching, DAM, ECAN, Espresso T1S, EtherGREEN, IdealBridge, In-Circuit Serial Programming, ICSP, INICnet, Intelligent Paralleling, Inter-Chip Connectivity, JitterBlocker, maxCrypto, maxView, memBrain, Mindi, MiWi, MPASM, MPF, MPLAB Certified logo, MPLIB, MPLINK, MultiTRAK, NetDetach, Omniscient Code Generation, PICDEM, PICDEM.net, PICkit, PICtail, PowerSmart, PureSilicon, QMatrix, REAL ICE, Ripple Blocker, RTAX, RTG4, SAM-ICE, Serial Quad I/O, simpleMAP, SimpliPHY, SmartBuffer, SMART-I.S., storClad, SQI, SuperSwitcher, SuperSwitcher II, Switchtec, SynchroPHY, Total Endurance, TSHARC, USBCheck, VariSense, VectorBlox, VeriPHY, ViewSpan, WiperLock, XpressConnect, and ZENA are trademarks of Microchip Technology Incorporated in the U.S.A. and other countries.

SQTP is a service mark of Microchip Technology Incorporated in the U.S.A.

The Adaptec logo, Frequency on Demand, Silicon Storage Technology, and Symmcom are registered trademarks of Microchip Technology Inc. in other countries.

GestIC is a registered trademark of Microchip Technology Germany II GmbH & Co. KG, a subsidiary of Microchip Technology Inc., in other countries.

All other trademarks mentioned herein are property of their respective companies.

© 2021, Microchip Technology Incorporated, Printed in the U.S.A., All Rights Reserved.

ISBN: 978-1-5224-8188-1

## Quality Management System

---

For information regarding Microchip's Quality Management Systems, please visit [www.microchip.com/quality](http://www.microchip.com/quality).





**MICROCHIP**

## Worldwide Sales and Service

AMERICAS	ASIA/PACIFIC	ASIA/PACIFIC	EUROPE
<b>Corporate Office</b> 2355 West Chandler Blvd. Chandler, AZ 85224-6199 Tel: 480-792-7200 Fax: 480-792-7277 Technical Support: <a href="http://www.microchip.com/support">www.microchip.com/support</a> Web Address: <a href="http://www.microchip.com">www.microchip.com</a>	<b>Australia - Sydney</b> Tel: 61-2-9868-6733 <b>China - Beijing</b> Tel: 86-10-8569-7000 <b>China - Chengdu</b> Tel: 86-28-8665-5511 <b>China - Chongqing</b> Tel: 86-23-8980-9588 <b>China - Dongguan</b> Tel: 86-769-8702-9880 <b>China - Guangzhou</b> Tel: 86-20-8755-8029 <b>China - Hangzhou</b> Tel: 86-571-8792-8115 <b>China - Hong Kong SAR</b> Tel: 852-2943-5100 <b>China - Nanjing</b> Tel: 86-25-8473-2460 <b>China - Qingdao</b> Tel: 86-532-8502-7355 <b>China - Shanghai</b> Tel: 86-21-3326-8000 <b>China - Shenyang</b> Tel: 86-24-2334-2829 <b>China - Shenzhen</b> Tel: 86-755-8864-2200 <b>China - Suzhou</b> Tel: 86-186-6233-1526 <b>China - Wuhan</b> Tel: 86-27-5980-5300 <b>China - Xian</b> Tel: 86-29-8833-7252 <b>China - Xiamen</b> Tel: 86-592-2388138 <b>China - Zhuhai</b> Tel: 86-756-3210040	<b>India - Bangalore</b> Tel: 91-80-3090-4444 <b>India - New Delhi</b> Tel: 91-11-4160-8631 <b>India - Pune</b> Tel: 91-20-4121-0141 <b>Japan - Osaka</b> Tel: 81-6-6152-7160 <b>Japan - Tokyo</b> Tel: 81-3-6880-3770 <b>Korea - Daegu</b> Tel: 82-53-744-4301 <b>Korea - Seoul</b> Tel: 82-2-554-7200 <b>Malaysia - Kuala Lumpur</b> Tel: 60-3-7651-7906 <b>Malaysia - Penang</b> Tel: 60-4-227-8870 <b>Philippines - Manila</b> Tel: 63-2-634-9065 <b>Singapore</b> Tel: 65-6334-8870 <b>Taiwan - Hsin Chu</b> Tel: 886-3-577-8366 <b>Taiwan - Kaohsiung</b> Tel: 886-7-213-7830 <b>Taiwan - Taipei</b> Tel: 886-2-2508-8600 <b>Thailand - Bangkok</b> Tel: 66-2-694-1351 <b>Vietnam - Ho Chi Minh</b> Tel: 84-28-5448-2100	<b>Austria - Wels</b> Tel: 43-7242-2244-39 Fax: 43-7242-2244-393 <b>Denmark - Copenhagen</b> Tel: 45-4485-5910 Fax: 45-4485-2829 <b>Finland - Espoo</b> Tel: 358-9-4520-820 <b>France - Paris</b> Tel: 33-1-69-53-63-20 Fax: 33-1-69-30-90-79 <b>Germany - Garching</b> Tel: 49-8931-9700 <b>Germany - Haan</b> Tel: 49-2129-3766400 <b>Germany - Heilbronn</b> Tel: 49-7131-72400 <b>Germany - Karlsruhe</b> Tel: 49-721-625370 <b>Germany - Munich</b> Tel: 49-89-627-144-0 Fax: 49-89-627-144-44 <b>Germany - Rosenheim</b> Tel: 49-8031-354-560 <b>Israel - Ra'anana</b> Tel: 972-9-744-7705 <b>Italy - Milan</b> Tel: 39-0331-742611 Fax: 39-0331-466781 <b>Italy - Padova</b> Tel: 39-049-7625286 <b>Netherlands - Drunen</b> Tel: 31-416-690399 Fax: 31-416-690340 <b>Norway - Trondheim</b> Tel: 47-72884388 <b>Poland - Warsaw</b> Tel: 48-22-3325737 <b>Romania - Bucharest</b> Tel: 40-21-407-87-50 <b>Spain - Madrid</b> Tel: 34-91-708-08-90 Fax: 34-91-708-08-91 <b>Sweden - Gothenberg</b> Tel: 46-31-704-60-40 <b>Sweden - Stockholm</b> Tel: 46-8-5090-4654 <b>UK - Wokingham</b> Tel: 44-118-921-5800 Fax: 44-118-921-5820