

TOSHIBA Bi-CMOS Integrated Circuit Silicon Monolithic

TB9080FG

3Phase DC Brushless Motor controller & gate driver

1. Overview

TB9080FG is a 3Phase Brushless Motor controller LSI for Automotive which build-in GATE driver for external MOSFET. Motor speed is controlled by external PWM signal Input or external Voltage and target Motor speed is adjusted automatically by TB9080FG. TB9080FG control external Motor by SINE WAVE Operation method.

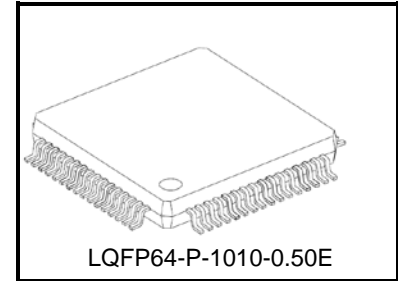

Weigt: 0.35g (Typ.)

2. Target Application:

Battery Cooling Fan, etc.

3. Features

- Build-in 3 Phase Brushless SINE WAVE Operation System Controller
- Build-in 6ch GATE-driver for external Nch MOSFETs
- Motor rotation speed control by external PWM signal or external DC voltage
- Selectable CW/CCW Motor rotation direction
- Detection circuits FEATURES
Motor Over Current MONITORING 、 INPUT VOLTAGE MONITORING 、
Over Temperature MONITORING 、 Motor Lock MONITORING 、
5V-Rregulator MONITORING 、 DCDC booster MONITORING 、
External Temperature MONITORING
- Operation voltage range 7 to18V
- Operation temperature range -40 to125°C
- Package LQFP64-P-1010-0.50E
- Stand by current 50μA (Ta = 25°C in sleep mode)
- AEC-Q100 qualified

If there are description that "[[G]]/RoHS COMPATIBLE", "[[G]]/RoHS [[Chemical symbol(s) of controlled substance(s)]]", "RoHS COMPATIBLE" or "RoHS COMPATIBLE, [[Chemical symbol(s) of controlled substance(s)]]>MCV" in packing box's label, the product corresponds to Europe RoHS order (2011 / 65 / EU).

4. Block Diagram

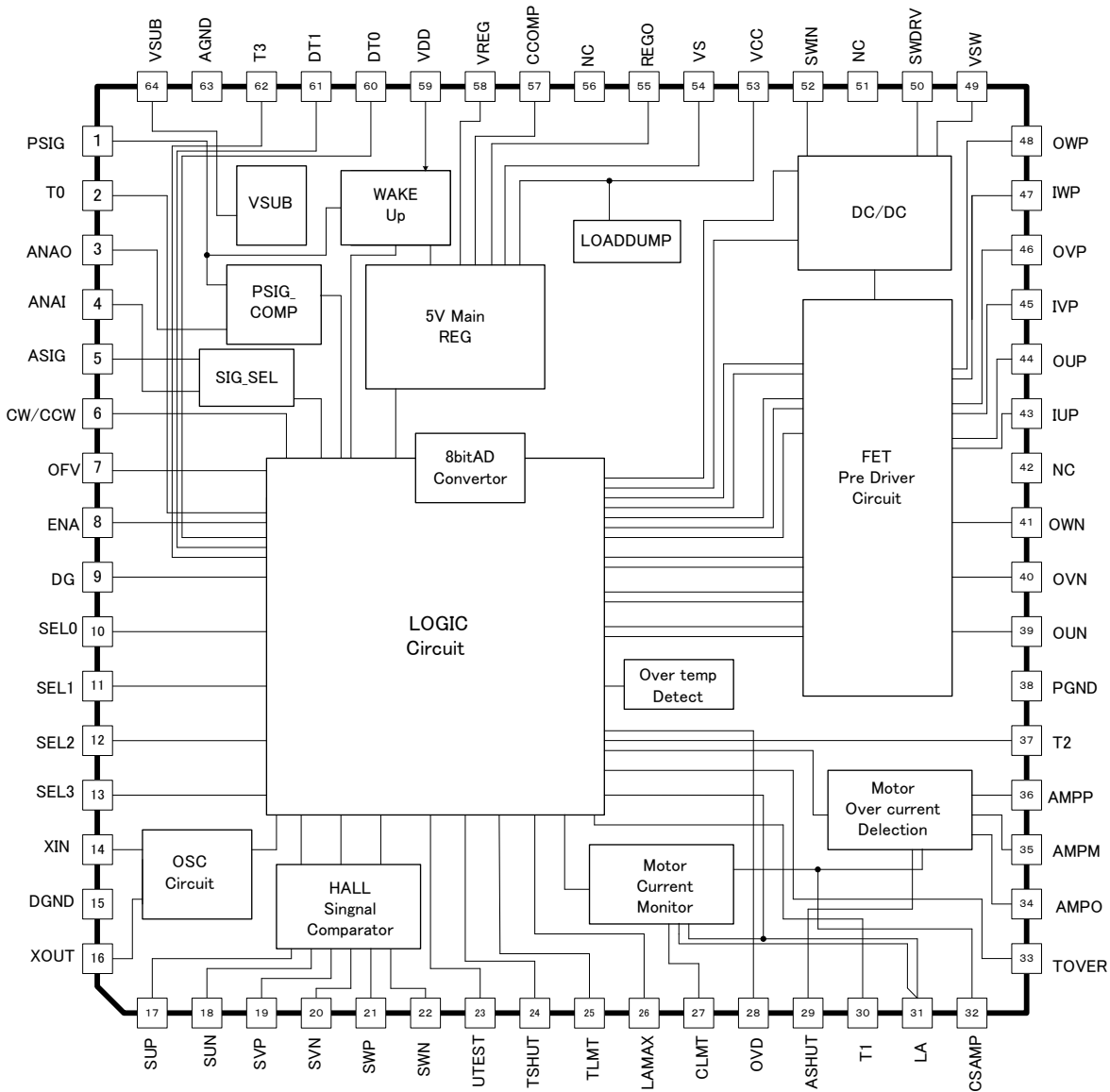

Note : Some of the functional blocks, circuits or constants in the block diagram may be omitted or simplified for explanatory purposes.

4.1 Functional block

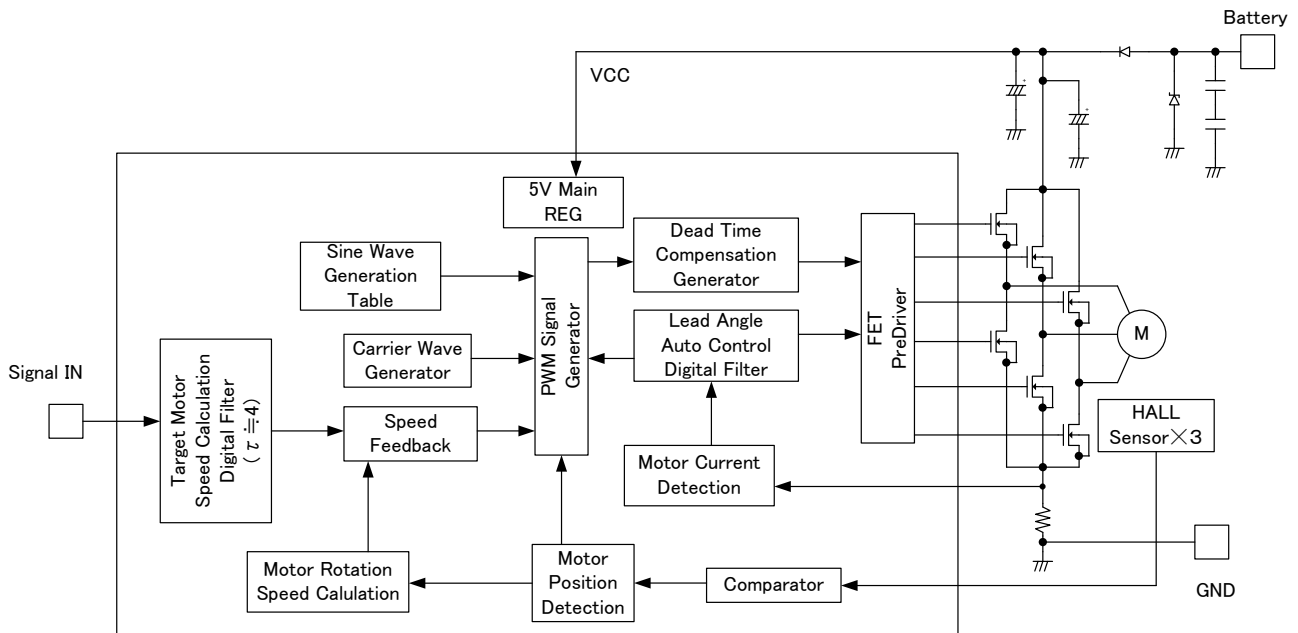

- Note1 : Some of the functional blocks, circuits or constants in the block diagram may be omitted or simplified for explanatory purposes.
- Note2 : Install the products correctly. Otherwise, it may result in break down, damage and/or deterioration to the product or equipment.
- Note3 : The application circuits shown in this document are provided for reference purposes only. Especially, a thorough evaluation is required on the phase of mass production design. Toshiba does not grant the use of any industrial property rights with these examples of application circuits.
- Note4 : Short Circuit between each Output signal, Output Signal and Power line (Battery, Regulator Output, GND) may make the cause of IC destruction or Damage.

5. Pin Description

Pin No.	Pin Name	Description
1	PSIG	Input of external PWM signal to set Motor rotation Speed.
2	T0	TEST PIN
3	ANAO	PSIG and converts the voltage.
4	ANAI	PSIG is a signal input terminal of number of rotations.
5	ASIG	Input for external Voltage to set Motor rotation Speed. DC voltage is set input by resistive voltage division.
6	CW/CCW	Input to change Motor rotation direction. Built-in pull up Resistor. "H" or "open" : Clock wise "L" : Counter Clock wise
7	OFV	OFV is an external capacitor connection terminal that generates an LPF for converting the motor rotational speed into a voltage. Please attach an external capacitor.
8	ENA	ENA is enable terminal. "H" : GATE-Driver Output Enable "L" : all GATE-Driver Output disable (all "L")
9	DG	DG is a Motor speed monitor and diagnosis monitor signal. A pulse with an asynchronous rotational speed cycle (120 deg.) Is output. During detection operation, there is output as duty.
10	SEL0	Select terminal is Max Motor rotation Speed.
11	SEL1	
12	SEL2	
13	SEL3	
14	XIN	XIN is Oscillator terminal. Please connect an external oscillator.
15	DGND	DGND is GND Terminal for Oscillator.
16	XOUT	XOUT is Oscillator terminal. Please connect an external oscillator.

5. Pin Description

Pin No.	Pin Name	Description
17	SUP	Input of U-Phase HALL Sensor (+)
18	SUN	Input of U-Phase HALL Sensor (-)
19	SVP	Input of V-Phase HALL Sensor (+)
20	SVN	Input of V-Phase HALL Sensor (-)
21	SWP	Input of W-Phase HALL Sensor (+)
22	SWN	Input of W-Phase HALL Sensor (-)
23	UTEST	Input for user Test input.
24	TSHUT	This is input for the setting external Over temperature.
25	TLMT	This is input for external critical temperature.
26	LAMAX	Input to set the Max. Lead Angle by external Voltage Divider.
27	CLMT	Input to set Motor Current Limit by external Voltage Divider.
28	OVD	Power Supply for each external Voltage Divider to set detection ("ASHUT", "CLMT", "LAMAX", "TOVER", "TLMT", "TSHUT").
29	ASHUT	It is a motor over-current setting input.
30	T1	TEST Pin
31	LA	This terminal should attach the capacitor for CLMT.
32	CSAMP	This terminal should attach the capacitor for sample hold control.

5. Pin Description (Cont.)

Pin No.	Pin Name	Description
33	TOVER	Input to measure external Temp.
34	AMPO	Output of build-in AMP for Motor Current measurement.
35	AMPM	Current sense PIN of build-in AMP(-).
36	AMPP	Current sense PIN of build-in AMP(+).
37	T2	TEST Pin.
38	PGND	This terminal is a ground of Pre Driver.
39	OUN	Output of U-phase Low side Nch MOSFET GATE signal. Please connect to FET Gate via a resistor.
40	OVN	Output of V-phase Low side Nch MOSFET GATE signal. Please connect to FET Gate via a resistor.
41	OWN	Output of W-phase Low side Nch MOSFET GATE signal. Please connect to FET Gate via a resistor.
42	N.C.	Please use it open.
43	IUP	U-phase High side reference voltage PIN. Please connect to FET via a resistor.
44	OUP	Output of U-phase High side Nch MOSFET GATE signal. Please connect to FET Gate via a resistor.
45	IVP	V-phase High side reference voltage PIN. Please connect to FET via a resistor.
46	OVP	Output of V-phase High side Nch MOSFET GATE signal. Please connect to FET Gate via a resistor.
47	IWP	W-phase High side reference voltage PIN Please connect to FET via a resistor.
48	OWP	Output of W-phase High side Nch MOSFET GATE signal. Please connect to FET Gate via a resistor.

5. Pin Description (Cont.)

Pin No.	Pin Name	Description
49	VSW	DCDC converter power supply output.
50	SWDRV	The boost control terminal of a DCDC converter.
51	N.C.	Please use it open.
52	SWIN	This is DCDC converter input pin.
53	VCC	Power supply of 7 to18V.
54	VS	This is VREG Regulator Current detection.
55	REGO	This is terminal of the transistor for VREG.
56	N.C.	Please use it open.
57	CCOMP	This is terminal to connect external Capacitor for Phase Compensation for VREG.
58	VREG	This is 5V power supply for control terminal.
59	VDD	5V power supply input.
60	DT0	This terminal is delay control 0 of output time.
61	DT1	This terminal is delay control 1 of output time.
62	T3	TEST PIN.
63	AGND	This terminal is analog ground of control circuit.
64	VSUB	VSUB is a power supply terminal for PSIG.

6. Function description

6.1 VREG regulator circuit (VCC/VS/REGO/CCOMP/VREG)

TB9080FG build-in a 5V main regulator to drive internal logic and a sub 5V power supply for PSIG that operates even in sleep mode.

The 5V main regulator uses an external PNP-Tr. It has a regulator circuit that generates 5V to driving the main logic circuit.

Please connect PNP-Tr. to the REGO terminal, and connect a phase compensation capacitor between the CCOMP terminal and the PNP-Tr. collector, and externally connect an overcurrent detection resistor between the VCC terminal and VS terminal. The current capability of the 5V power supply is determined by the characteristics of the external PNP-Tr. and the output current from the REGO pin.

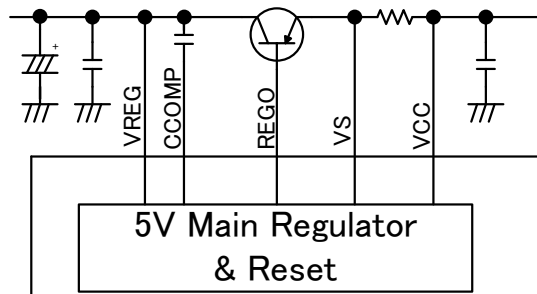

The over current detection circuit is a circuit that detects the current flowing in the 5 V power supply circuit with the external resistor R, and turns off the REGO pin when the voltage drops more than Vlimit so that the current does not flow more than a certain amount.

This circuit is effective when an excessive current may flow when it is used for an external microcomputer etc.

Detection electric current : $I = (VCC - Vlimit) / R$

Vlimit : VCC-0.4V to VCC-0.15V

6.2 SUB 5V regulator (V_{SUB})

SLEEP mode operation is performed using the 5 V SUB regulator.

In SLEEP mode operation, 5 V main regulator circuit is stopped and all pre-driver outputs are fixed low to reduce power consumption.

Use a 5V SUB regulator only for the pull-up power supply of the PSIG pin.

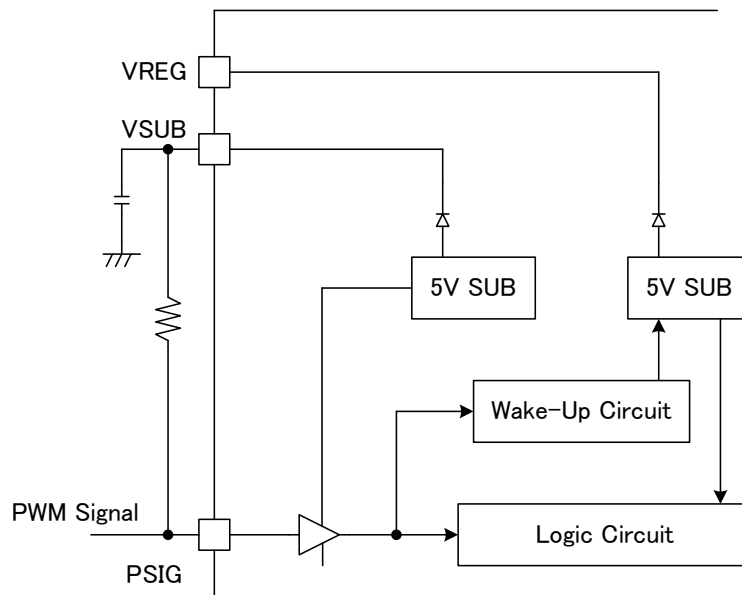

Note : Please do not use the 5V SUB regulator (V_{SUB}) as a power supply (Hall device supply, others) of an external element.

6.3 Enable terminal (ENA)

“H” : GATE-Driver Output Enable

“L” : all GATE-Driver Output disable (all “L”)

When Pre-Driver is a Low output, Exterior Nch MOSFET becomes Hi-Z

6.4 Rotation speed input (PSIG/ANA0/ANAI/ASIG)

There are two ways to control the motor speed both PSIG drive and ASIG drive. It becomes a PSIG input when it detects more than 7.6 Hz, and becomes an ASIG pin input when it detects less than 7.6 Hz.

6.4.1 PWM target rotation data input (PSIG)

The PSIG terminal is an input terminal that sets the target (command) motor rotation data by the PWM duty signal from the outside.

In addition, it controls sleep / wakeup / drive start (12% or more) / stop (8% or less), and PSIG / ASIG switching according to the PWM Duty value input to the PSIG pin.

The frequency range of target rotation data of PSIG is 7.6Hz to 1kHz, and according to ASIG when the input PWM duty becomes 100%.

Although an input of 1 kHz or more is also accepted, the PWM Duty value may change.

Note1: Motor drive starts when the PWM Duty value of PSIG terminal input is 12% or more. After startup, it stop at 8% or less. The IC enters sleep mode when it detects a high level for a certain period of time or more from the PSIG pin input.

Note2: If the edge cannot be detected from the input signal of PSIG pin, or if the input frequency of PSIG terminal is less than 7.6 Hz, the command rotation data follows the data of the analog input signal set by ASIG terminal.

6.4.2 Analog target rotation data input (ASIG)

To select ASIG, please input 0 V to the PSIG pin. The ASIG terminal is an input terminal for setting the target motor rotation data from the outside according to the voltage value. In addition, drive start / stop control is also performed depending on the voltage value input to the ASIG terminal.

Note1: Motor drive starts when the input voltage value of the ASIG terminal is 0.6 V (Typ.) Or more. After startup, stop the startup at 0.4 V (Typ.) Or less.

Note2: The sleep mode is not entered because the PSIG pin input is set to low level.

6.5 SLEEP MODE

6.5.1 SLEEP mode Start

Transition to and release from SLEEP mode is performed by the PWM signal input from the PSIG pin. If High period continues to be 524 ms or more at the PSIG terminal, TB9080FG shifts to SLEEP mode. In the SLEEP mode, the 5V regulator is turned off, the Logic circuit is reset, and all pre-driver outputs are low.

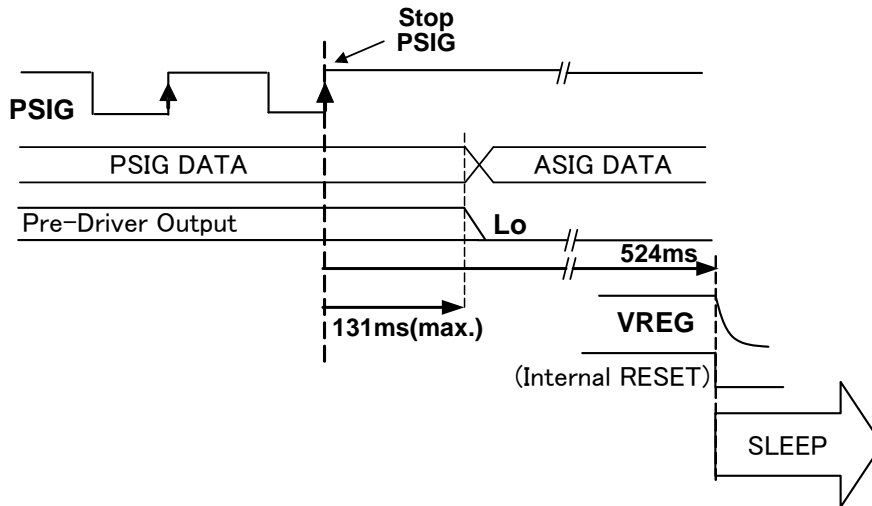

6.5.2 Return to Sleep Operation

- ① VREG restart by detecting falling edge of PSIG input.
- ② When VREG is over 4.7V(Typ.), internal Reset is off and logic circuit start operation.
- ③ After 8.2ms(Typ.) passed, it accepts ASIG data.
- ④ When rising Edge of PSIG is detected 2times, PSIG operation restart. But, in case that PSIG frequency is lower than 131ms. ASIG Operation is kept.

Note1 : Timing chart may be simplified for the explanation.

6.6 Rotation Direction (CW/CCW)

Motor rotation direction is set by PIN" CW/CCW".

- PIN" CW/CCW" = H CW (Clockwise direction)
- PIN" CW/CCW" = L CCW (Counter Clockwise direction)

Note2: If the direction of rotation is changed by the above operation while the motor is rotating, a large current may flow due to the back electromotive force of the motor and the driver may be destroyed.

Please be sure to stop the motor once before switching the above rotation direction.

6.7 Max Motor rotation Speed. (SEL0/SEL1/SEL2/SEL3)

The maximum electric angle number of rotations of the Max Motor rotation Speed to be used is set up at 4 bits of SEL0 - SEL3 terminal.

Depending on Motor characteristics and the supply voltage condition motor rotation speed may not actually reach to the Max. speed which is set in the above table. (base clock 8.0MHz(Typ.))

Motor Max. Rotational Speed Select Table

(rpm)

	SELECT PIN				Motor mechanical angle. (P:Pole, S:Slot)			
					4p/6S	6P/9S	8P/12S	10P/12S
	SEL0	SEL1	SEL2	SEL3	1/2	1/3	1/4	1/5
15	1	1	1	1	4,000	2,667	2,000	1,600
14	0	1	1	1	4,500	3,000	2,250	1,800
13	1	0	1	1	5,000	3,333	2,500	2,000
12	0	0	1	1	5,500	3,667	2,750	2,200
11	1	1	0	1	6,000	4,000	3,000	2,400
10	0	1	0	1	6,750	4,500	3,375	2,700
9	1	0	0	1	7,500	5,000	3,750	3,000
8	0	0	0	1	8,250	5,500	4,125	3,300
7	1	1	1	0	9,000	6,000	4,500	3,600
6	0	1	1	0	10,000	6,667	5,000	4,000
5	1	0	1	0	11,000	7,333	5,500	4,400
4	0	0	1	0	11,250	7,500	5,625	4,500
3	1	1	0	0	12,000	8,000	6,000	4,800
2	0	1	0	0	12,500	8,333	6,250	5,000
1	1	0	0	0	13,750	9,167	6,875	5,500
0	0	0	0	0	15,000	10,000	7,500	6,000

6.8 HALL sensor mounting location(SUP/SUN/SVP/SVN/SWP/SWN)

TB9080FG Shapes the Hall sensor signal from the Hall element and pass it to Logic.

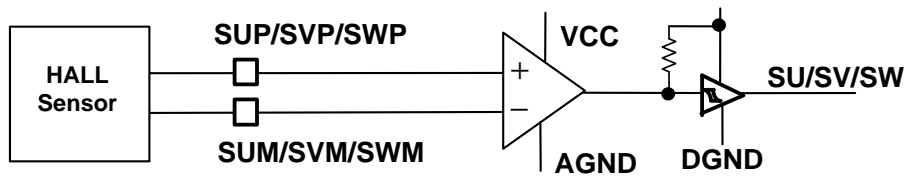

Please attach the sensor where the sensor switching signal is 30deg late place from zero cross point of motor induced voltage generated by external power.

Below figure explains motor induced voltage and sensor output in clockwise rotation.

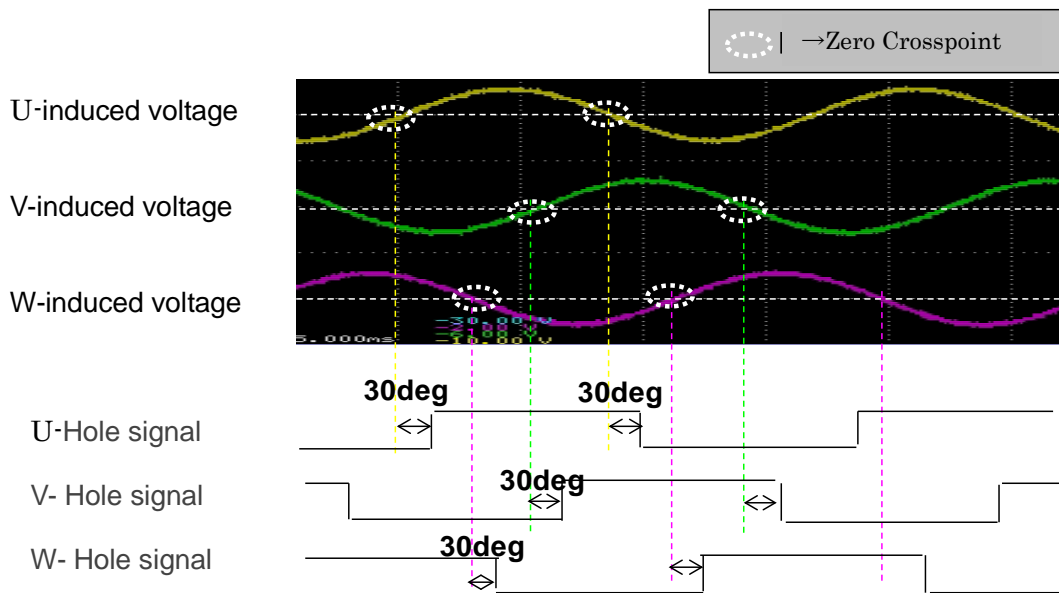

Note : Graph is reference consistently.

6.9 Motor rotation monitor signal (OFV)

One shot pulse synchronized with the switching timing of Hall sensor signal in each phase (every 60 degrees mechanical angle of each phase) is output from the terminal OFV terminal.

6.10 Delay control of output time (DT0/DT1)

The following driver delay correction can be set for external MOSFET drive. (Please set the driver delay correction according to the external FET.)

DT0	DT1	Delay Time
0	0	3μs (Typ.)
1	0	2μs (Typ.)
0	1	1μs (Typ.)
1 (or open)	1 (or open)	0μs (no correction)

6.11 Lead Angle Max Setting (LAMAX)

The shunt resistance constantly monitors the motor drive current and automatically sets the optimum lead angle according to the rotation speed.

When the voltage at the LAMAX terminal rises to 1.5 V or more, the maximum lead angle value is fixed at 45 degrees thereafter.

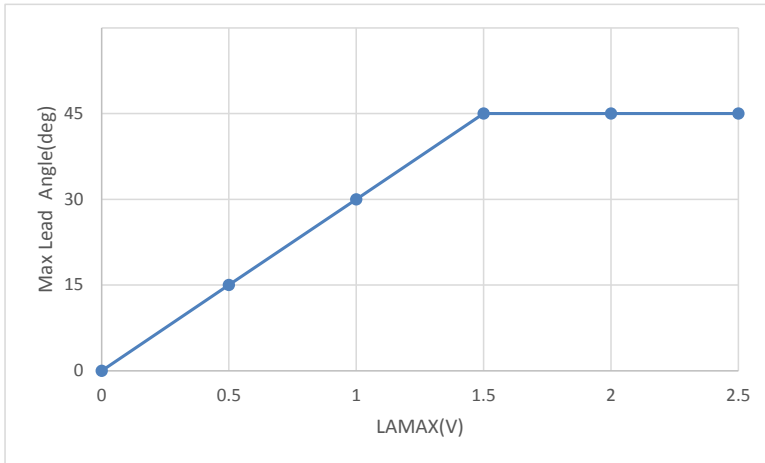

6.12 High side gate voltage booster circuit (SWIN/SWDRV/VSW)

The voltage rise circuit which generates VCC+12V (Typ.) as a gate driving signal power supply of high side MOSFET of external MOSFET for a motor drive is built in.

Oscillation frequency: 95 kHz (fixed) Duty = 50%, (oscillator 8 MHz)

The boost voltage normally operates to be VCC + 12V.

6.13 Oscillation circuit (XIN/XOUT)

TB9080FG build-in oscillation circuit for internal. Recommended external Oscillator is 8MHz (Typ.) to connect between PIN"XIN" and "XOUT". Internal circuit operation, such as PWM Output is based on this external OSC. Thus, the tolerant of Ceramic Oscillator Level is minimum required for external OSC. The following is the reference of PWM Output frequency based on each external OSC. (All of timing in this Specification is based on 8MHz (Typ.) external OSC)

The circuit incorporates a feedback resistor for oscillation.

Oscillator	PWM frequency (Typ.)
8MHz	15.7kHz

Note1:The frequency of a PWM signal and other time changes by an oscillation child.

Note2:The time written in these specifications is written on the basis of an 8-MHz clock.

6.14 Motor induced voltage and fixed position of sensor (OVD)

You can use OVD terminal as power supply of resistor divider connected to TSHUT, TLMT, LAMAX, CLMT, and ASHUT. But voltage drops at output current over 3mA, so please use within the ratings.

$I_o = 3mA$ (Typ.)

6.15 Digital Filter

TB9080FG build-in Digital Filter to protect Rush Current of external MOSFET. This Digital Filter makes Motor Start Up delay by Time Constance $\tau = 4.0s$ (Typ.) as follows.

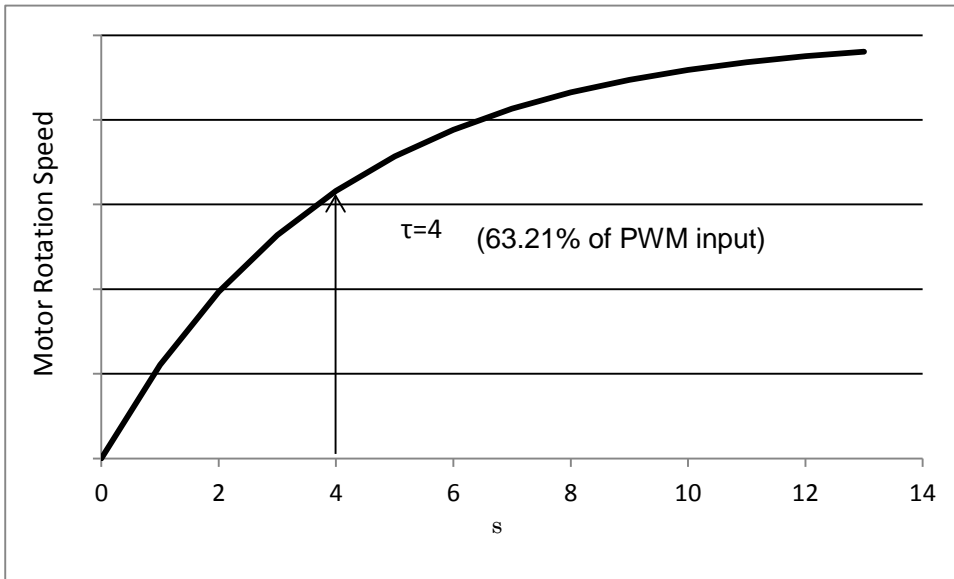

Note: Timing charts may be simplified for explanatory purpose.

6.16 External Over Temperature Detection (TOVER/TLMT/TSHUT)

This circuit is the circuit for detection of overheat outside the IC.

Attach a temperature thermistor outside to detect.

Two-step detection is possible. First, the temperature limiter works to lower the target motor speed by 2% / digit.

If the temperature still rises, TB9080FG can turn the pre driver off with the temperature shutdown setting.

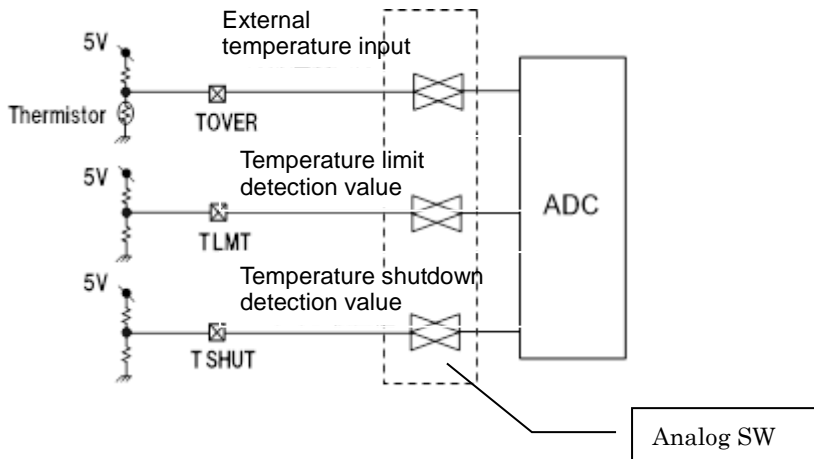

PIN	Notes
TOVER	TOVER is the input terminal which detects the external Temperature. This input is connected to a Voltage divider by Thermistor. This terminal voltage is compared to TLMT terminal voltage and TSHUT terminal voltage. When not using this function, attach a pull-up resistor.
TLMT	When the thermistor resistance voltage division value of the TOVER terminal becomes lower than the resistance voltage division of the TLMT terminal ($V_{TOVER} < V_{TLMT}$), the motor drive output is attenuated regardless of the target motor rotation speed input to the PSIG or ASIG terminal. This Temp. Limiter function can be disable by connecting PIN"TLMT" to GND. Built-in pull-down resistor 500KΩ.
TSHUT	This terminal is for setting the temperature to turn off the pre driver. The release level is internally fixed at +1.0 V from TSHUT level. The temperature shutdown detection operation returns to normal operation when the measured value TOVER becomes 1 V higher than TSHUT (shutdown detection value) (The TSHUT pin is internally connected to a 500kΩ pull-down resistor.)

Note : Some of the functional block, circuit or constants in the block diagram may be omitted or simplified explanatory purpose.

7. Abnormal Detection

TB9080FG build-in various Abnormal Detection functions, and outputs the information of Abnormal Detection signal from PIN"DG" (except some detection).

7.1 Abnormal detection view

	Item	Detection Point	Ret. to Normal	Action	PIN"DG" Output	Detection point set
Current	VREG Current Limiter	Voltage drop 0.3V (Typ.) or Over	Voltage up 0.3V(Typ.) or Lower	5V Regulator off	-	Ex. Resistor (VS-VCC)
	Motor Over Current	external shunt resistance value	into Sleep mode or restart	All Pre-driver "L" (Motor output Hi-Z)	90%/10Hz	External shunt resistor
	Motor Current Limiter	External resistance voltage division (terminal "CLMT") setting		Output PWM Duty Decay	90%/Rotation signal	PIN"CLMT" Ex. Voltage
	Pre-driver Over Current	Over 130mA (min.)	into Sleep mode or restart	All Pre-driver OFF"Hi-Z" (Motor outputs Hi-Z)	90%/10Hz	Fixed
	DCDC Booster circuit Over Current	1A (Typ.)	into Sleep mode or restart	All Pre-driver "L" (Motor output Hi-Z) DCDC booster clock stop, SWIN output to GND	90%/10Hz	Fixed
Voltage	VCC Low Voltage	Under 5.9V (Typ.)	Over 6.4V (Typ.)	All Pre-driver "L" (Motor output Hi-Z)	70%/10 Hz	Fixed
	VCC Over Voltage	Over 20V (Typ.)	Under 19.5V (Typ.)	All Pre-driver "L" (Motor output Hi-Z) DCDC booster clock stop	70%/10Hz	Fixed
	DCDC Booster Low Voltage	Under VCC+5V (Typ.)	Over VCC+5.5V (Typ.)	All Pre-driver "L" (Motor outputs Hi-Z)	70%/10Hz	Fixed
	PIN"VSW" Open Detection	Under 3V (Typ.)	Over 3.5V (Typ.)	All Pre-driver "L" (Motor output Hi-Z) DCDC booster clock stop	70%/10Hz	Fixed
	Boost circuit Over Voltage	Over 38V (Typ.)	Lower 37.5V (Typ.)	DCDC Booster clock stop	Rotation signal	Fixed
	External diode connection failure detection for boost circuit (SWDRV pin over voltage)	Over 40V (Max.)	Connection of a diode	SWDRV clamp (Active clamp)	Rotation signal	Fixed
	Under VREG voltage	Under 4.55V (Typ.)	Over 4.7V (Typ.)	Logic circuit reset	-	Fixed
Temperature	IC inside Over temperature	Over 165°C (Typ.)	Lower 155°C(Typ.)	All pre-driver outputs Hi-Z (Motor outputs Hi-Z) Boost circuit clock stop	30%/10Hz	Fixed
	Outside Over Temperature (shutdown)	Compare both of TOVER terminal voltage and TSHUT terminal voltage		All Pre-driver "L" (Motor outputs Hi-Z)	30%/10Hz	External thermistor/resistance divider
	Outside Over Temperature (limiter)	Compare both of TOVER terminal voltage and TLMT terminal voltage		Output PWM Duty Decay	30%/10Hz or Rotation signal	External thermistor/resistance divider

Note: When the rotation cycle is 20 Hz or less, it will be 10 Hz (fixed).

	Detection Item	Detection condition	Release condition	Detection behavior	PIN"DG" Output	Detection point set
Others	Motor lock (detection of low actual rotation speed against target rotational speed)	[detection condition] target rotational speed		All pre-driver outputs off (Motor outputs Hi-Z) ※ If it has not reached the lock judgment just after the start of rotation, it will be Duty 50% / 10Hz. It will be 10% / 10Hz after the lock judgment.	10%/10Hz	Fixed
		Actual speed	Duration			
Under 32		Under 1/8 :3.5s				
32 -63		Under 1/8 :2.0s				
64 -95		Under 1/16 :1.5s				
Over 96		Under 1/16 :1.0s				
	Reference: 96 = about 1.9 V (ANAO voltage) [release condition] goes to sleep mode change CW/CCW re-start Power					
	Hall sensor signal failure	No HALL signal Input during 3.5s. (Typ.) after startup.	Transition to SLEEP mode or power on again	All pre-driver "L" (Motor outputs Hi-Z)	10%/10Hz	Fixed
	PSIG Low rotation	Under 7.6Hz(Typ.) (Under.)	Under 7.6Hz(Typ.) (Over.)	Change ASIG	No change (State continuation)	Fixed
	Normal	The pulse of the cycle (120deg.) of asynchronous revolving speed calculated from the value which carried out A/D conversion of the OFV is outputted.			50% Not Synchro	-

Note : target rotational speed is a voltage by which internal AD conversion of input PWM signal is done after averaged by external CR low pass filter.

7.2 Abnormal Current Detection

7.2.1 Motor Over Current Detection (AMPP/AMPM/AMPO/ASHUT)

An amplifier for motor current detection and a comparator are built in. The current detected by the external shunt resistor R_s is amplified by the built-in amplifier, the value is externally set to the resistor divider. If the detected value is exceeded, the following overcurrent detection operation is performed.

The motor over current detection value is set by the resistive voltage divider externally connected to the ASHUT terminal. However, please set this voltage value to less than 3.5V. The voltage (motor current) detected by the external shunt resistor is amplified by the built-in amplifier, and this amplification factor is set by $\text{Gain} = R_{mo} / R_{mg}$ by the external resistors R_{mo} and R_{mg} . As shown in the figure below, please set the external resistance so that $R_p = R_{mg}$ and $R_{pg} = R_{mo}$. The internally amplified detection voltage is compared with the resistance voltage division set to the terminal "ASHUT", and when it exceeds that, the following motor over-current detection operation is started, and a rectangle of 10 Hz frequency and 90% duty from the DG terminal Output a wave.

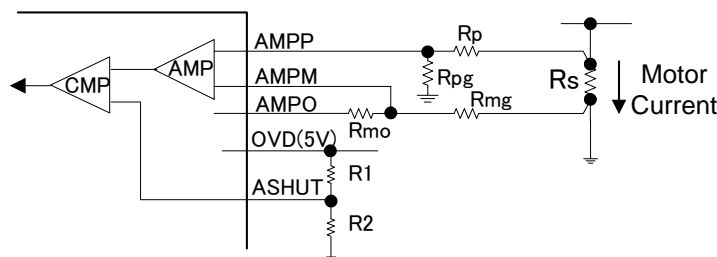

(Note) $\text{Gain} = R_{mo} / R_{mg}$
Please set $R_p = R_{mg}$, $R_{pg} = R_{mo}$ to operate as a differential amplifier.

(Setting Example)

In case of setting Motor Over Current 100A, Shunt Resistor $R_s=2\text{m}\Omega$

Voltage which is detected by R_s : $100\text{A} \times 2\text{m}\Omega = 0.2(\text{V})$
 Detection voltage should be lower than 3.5V, set amplifying rate by x10 (2V)
 to set Amp Rate=10, $R_p=R_{mg}=12\text{k}\Omega$ 、 $R_{pg}=R_{mo}=120\text{k}\Omega$
 to set voltage of ASHUT=2V, $R_1=15\Omega$ 、 $R_2=10\Omega$

7.2.2 Motor Current Limit (CLMT) (LA)

A peak hold is performed using the capacitor of connection of the signal amplified with current amplifier with CSAMP.

The external resistance partial pressure connected to the capacitor voltage of LA terminal and a CLMT terminal is compared, and when LA terminal value becomes high, in order to reduce motor driving current, motor current limiting circuit control is performed.

7.3 Internal Over Temperature Detection

An over temperature detection function is incorporated in the IC, and all pre driver outputs (OUP, OVP, OWP, OUN, OVN, OWN) are turned off (Hi-Z) when the CHIP temperature reaches 165 °C(Typ.) or higher. Stop the clock (boost stop) of the internal booster circuit.

When over temperature detection is detected, 10Hz Duty 30% signal is output from DG terminal.

When the CHIP internal temperature falls below 155 °C (Typ.), This detection operation is canceled and normal operation is released.

Once the overheat detection is performed, the detection operation continues for 256ms (Typ.)

Immediately after that even if the CHIP temperature falls to 155 °C, and the continuation detection or detection operation release is judged in the internal temperature state after 256ms.

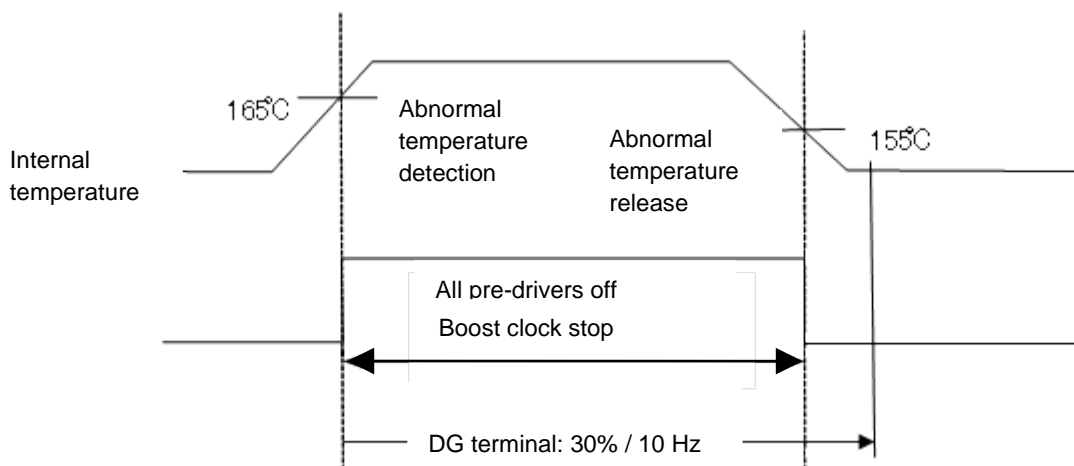

Note : The Absolute maximum Temperature of TB9080FG is 150deg. This Over Temperature Detection function does not intend to limit the CHIP temperature. Thus, the above Absolute Maximum Temperature never is over to use TB9080FG. If any of these rating would be exceeded during operation, the device electrical characteristics may be irreparably altered and the reliability and lifetime of the device can no longer be guaranteed. Moreover, these operations with exceeded ratings may cause break down, damage and/or degradation to any other equipment. Applications using the device should be designed such that each maximum rating will never be exceeded in any operating conditions. Before using, creating and/or producing designs, refer to and comply with the precautions and conditions set forth in this documents. This over Temp. Detection is worded over the Max. Rating Temperature and shipping test does not perform at the Max. Rating Temp.

8. Absolute maximum rating

(Ta = 25°C)

Characteristic	Applicable Pins	Symb ol	Rating	Unit	Comment
Supply Voltage 1	VCC	VCC	0 to 40	V	VCC = 25V to 40V (Within 1s)
Supply Voltage 2	VSW	VSW	0 to 40	V	-
Supply Voltage 3	VDD	VDD	0 to 5.5	V	-
Output current 1	ANAO, DG, OVD, OFV, REGO, VSUB	Iin1	±10	mA	-
Output current 2	AMPO	Iin2	±5	mA	-
Input Voltage 1	VS	Vin1	-0.3 to VCC+0.3	V	VCC = 25V to 40V (Within 1s)
Input Voltage2	IUP, IVP, IWP	Vin2	0.3 to VSW+0.3	V	VCC = 25 to 40V (Within 1s)
Input Voltage 3	PSIG, ANAI, ASIG, T0, OFV, T1, XIN, SEL0, SEL1, SEL2, SEL3, ENA, SUP, SUN, SVP, SVN, SWP, SWN, DT0, DT1, T2, CLMT, ASHUT, T3, LA, CSAMP, TSHUT, TLMT, AMPP, AMPM, CW/CCW, UTEST, LAMAX, TOVER	Vin3	-0.3 to VDD+0.3	V	-
Output Voltage 1	OUP, OVP, OWP, SWDRV	Vout1	-0.3 to VSW+0.3	V	VCC = 25 to 40V (Within 1s)
Output Voltage 2	OUN, OVN, OWN, SWIN	Vout2	-0.3 to VCC+0.3	V	-
Output Voltage 3	REGO	Vout3	-0.3 to VCC+0.3	V	-
Output Voltage 4	VSUB, ANAO, XOUT, DG, OVD, AMPO, OFV, CCOMP	Vout4	-0.3 to VDD+0.3	V	VDD = VREG
Power dissipation	-	PD	2.0	W	See below PD curve
Operation ambient Temperature	-	Ta	-40 to 125	°C	-
Storage temperature	-	Tstg	-55 to 150	°C	-

Note : The absolute maximum rating of a semiconductor device are a standard of ratings that must not be exceeded during operation, even for an instant. Exceeding the rating may cause the device breakdown, damage or deterioration, and may damage any other equipment. Applications using the device should be designed such that the absolute maximum ratings will never be exceeded in any operating conditions. Please use within the specified operating range.

8.1 Power dissipation

LQFP64-P-1010-0.50E

JEDEC 4 layer PCB (76.2mm×114.3mm×1.6mm)

$\Theta_{ja} = 48.5^{\circ}\text{C/W}$

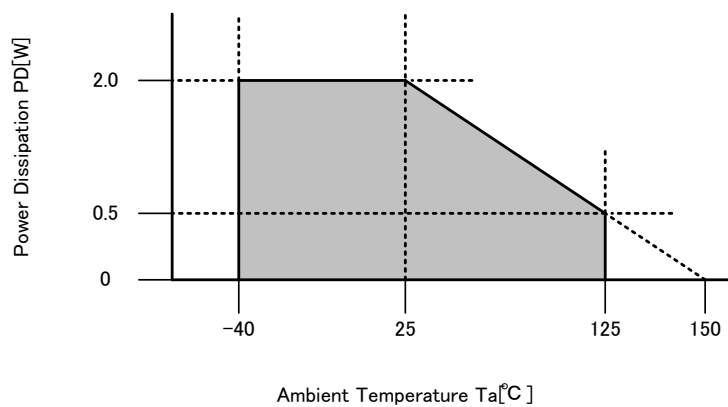

8.2 Operational range

Characteristics	Symbol	Applicable Pin	Test Condition	MIN	TYP	MAX	Unit
Operation Voltage range	Vcc ope	VCC	-	7	-	18	V
Operation Temperature Range	Topr	-	-	-40	-	125	°C

9. Electrical Characteristics

9.1 Consumption current

VCC = 7 to 18 V, Ta = -40 to 125°C.

Characteristics	Symbol	Applicable Pin	Test Condition	MIN	TYP	MAX	Unit
Sleep consumption Current	Isleep-h	VCC	Sleep mode Ta=-40 to 125°C	-	50	200	μA
	Isleep		Sleep mode, Ta = 25°C	-	50	100	μA
Consumption Current	Icc		Normal operation	-	7.5	22	mA

9.2 PSIG characteristics

VCC = 7 to 18 V, Ta = -40 to 125°C

Characteristics	Symbol	Applicable Pin	Test Condition	Rating			Unit
				MIN	TYP	MAX	
Input voltage range	Vinp	PSIG	—	0	—	VSUB	V
Input detection voltage H	Vin-h		—	0.49*VREG	0.52*VREG	0.55V*VREG	V
Input detection voltage L	Vin-l		—	0.45*VREG	0.48*VREG	0.51*VREG	V
Input HYS voltage	Vin-hys		—	0.02*VREG	0.04*VREG	0.08*VREG	V
Input current	Iih		VIN=5V, VDD=5V	-10	0	10	μA
	Iil		Vin=0V	-20	-10	-5	
Wake-up detection voltage (sleep release)	Vwake		—	0.2*VSUB	0.4*VSUB	0.5*VSUB	V
Motor drive start input duty	Duty-Lst		—	11	12	13	%
Motor drive stop input duty	Duty-Lsp		—	7	8	9	%
Motor drive maximum input duty	Duty-max		—	88	90	92	%
Clamp current	IinPSIG		PSIG=18V	—	1	3	mA
Sleep mode entry time	Tsleep		f=8MHz	—	524	—	ms

9.3 ANAI characteristics

VCC = 7 to 18 V, Ta = -40 to 125°C

Characteristics	Symbol	Applicable Pin	Test Condition	Rating			Unit
				MIN	TYP	MAX	
Input voltage range	Vin	ANAI	—	0	—	VREG	V
Input current	lih		VIN=5V, VDD=5V	-10	—	10	μA
	lil		Vin=0V	-10	—	10	
Motor drive start input voltage	ANA-st		—	0.11*VDD	0.12*VDD	0.13*VDD	V
Motor drive stop input voltage	ANA-sp		—	0.07*VDD	0.08*VDD	0.09*VDD	V
Motor drive maximum input voltage	ANA-mx		—	0.88*VDD	0.90*VDD	0.92*VDD	V

9.4 ASIG characteristics

VCC = 7 to 18 V, Ta = -40 to 125°C

Characteristics	Symbol	Applicable Pin	Test Condition	Rating			Unit
				MIN	TYP	MAX	
Input voltage range	Vin	ASIG	—	0	—	VREG	V
Input current	lih		VIN=5V, VDD=5V	-10	0	10	μA
	lil		Vin=0V	-10	0	10	
Motor drive start input voltage	ASG-st		—	0.11*VDD	0.12*VDD	0.13*VDD	V
Motor drive stop input voltage	ASG-sp		—	0.07*VDD	0.08*VDD	0.09*VDD	V
Motor drive maximum input voltage	ASG-mx		—	0.88*VDD	0.90*VDD	0.92*VDD	V

9.5 VSUB characteristics

VCC = 7 to 18 V, Ta = -40 to 125°C

Characteristics	Symbol	Applicable Pin	Test Condition	Rating			Unit
				MIN	TYP	MAX	
VSUB output voltage1	Vsub1	VSUB	VCC=7 to18V, OUT=0mA	3.2	5	5.5	V
VSUB output voltage2	Vsub2		VCC=7 to18V, OUT=-5mA	3.2	5	5.5	V
Clamp current	lin_vsub		VCC=18V, R=1kΩ	5	12	15	mA
Clamp voltage	Vout		VCC=18V, R=1kΩ	—	5.7	—	V

9.6 VREG characteristics

VCC = 7 to 18 V, Ta = -40 to 125°C

Characteristics	Symbol	Applicable Pin	Test Condition	Rating			Unit
				MIN	TYP	MAX	
5V supply output voltage	Vreg	VREG	IL=0mA	4.8	5	5.2	V
Input stability	Vinstb		VCC=7 to18V	—	0.1	0.5	%
Road stability	Load Stab		IL=1 to40mA	—	0.2	1	%
Reset voltage	Vth-l		—	0.87*VREG	0.91*VREG	0.94*VREG	V
Reset release voltage	Vth-h		—	0.91*VREG	0.94*VREG	0.97*VREG	V
REGO sink current ability	Isink	REGO	VREG=4.5V	1	—	—	mA
Over current detection voltage	Vlimit	VS	VCC-VS	0.15	0.3	0.4	V

9.7 OSC characteristics

VCC = 7 to 18 V, Ta = -40 to 125°C

Characteristics	Symbol	Applicable Pin	Test Condition	Rating			Unit
				MIN	TYP	MAX	
Oscillation frequency	Fosc	XIN, XOUT	External ceramic oscillator	—	8	—	MHz

9.8 HALL characteristics

VCC = 7 to 18 V, Ta = -40 to 125°C

Characteristics	Symbol	Applicable Pin	Test Condition	Rating			Unit
				MIN	TYP	MAX	
Input voltage range	Vin1	SUN,SUP, SVN,SVP, SWN,SWP	—	0	—	VREG	V
Common phase input voltage range	Vin2		—	0	—	VREG-1.7	V
Input bias current	Ibias		Vin=0V	-2.2	-0.2	—	μA
input offset current	Ioffset		—	—	0.02	0.4	μA
CMP HYS voltage	Vhys		—	—	2	10	22

9.9 DCDC characteristics

VCC = 7 to 18 V, Ta = -40 to 125°C

Characteristics	Symbol	Applicable Pin	Test Condition	Rating			Unit
				MIN	TYP	MAX	
Output frequency	Hz	SWDRV	OSC=8MHz	—	95 (Duty=50%)	—	kHz
Off leak current	Ioffl	SWDRV	VCC=18V, SWDRV=30V	—	0	12	μA
Output ON resistance	Ronh	SWIN	IOU=-200mA	—	—	3.5	Ω
Output ON resistance	Ronl		IOU=200mA	—	—	3.5	
Output ON resistance	Ronl	SWDRV	IOU=200mA	—	10	25	
Output off leak	Ioffh	SWIN	Vout=0V	-10	—	10	μA
Output off leak	Ioffl		Vout=18V	-10	—	10	
Output turn on time (PDMOS)	Ton	SWIN	VCC=12V, RL=120Ω, Vout:20%→80%	—	0.5	1	μs
Output turn off time (PDMOS)	Toff		VCC=12V, RL=120Ω, Vout:80%→20%	—	0.5	1	
Output turn on time	Ton	SWDRV	VCC=12V, RL=120Ω, Vout:20%→80%	—	0.5	1	
Output turn off time	Toff		VCC=12V, RL=120Ω, Vout:80%→20%	—	0.5	1	
Voltage boost stop voltage	Vsw1	VSW	—	VCC+9	VCC+12	VCC+15	V
Voltage boost start voltage	Vsw2		—	VCC+8.9	VCC+11.9	VCC+14.9	
Low voltage detection	VDCDC-L	VCC	—	VCC+3.5	VCC+5.0	VCC+7.0	
Low voltage detection release	VDCDC-H		—	VCC+4.5	VCC+5.5	VCC+8.5	
Over current detection	-	SWIN	—	0.6	1	1.5	A
Over voltage detection	Vcph-h	VSW	—	35	38	40	V
Over voltage detection release	Vcph-l	VSW	—	34.5	37.5	39.5	V
Voltage monitoring cycle	-	-	—	—	128	—	μs
boosting diode open clamp voltage	Vclp	SWDRV	—	34	37	40	V
VSW open detection voltage	Vopen-l	VSW	—	2	3	4	V
VSW open detection release voltage	Vopen-h	VSW	—	2.5	3.5	4.5	V

9.10 Pre-driver characteristics

VCC = 7 to 18 V, Ta = -40 to 125°C

Characteristics	Symbol	Applicable Pin	Test Condition	Rating			Unit
				MIN	TYP	MAX	
Output voltage	Voh1	OUP,OVP,OWP	IOUT=50mA	VSW-1.7	VSW-0.85	VSW	V
	Vol1		IUP,IVP,IWP=GN D IOUT=-50mA	—	0.85	1.7	
	Voh2	OUN,OVN,OWN	IOUT=50mA	VCC-1.7	VCC-0.85	VCC	
	Vol2		IOUT=-50mA	—	0.85	1.7	
	Voh3		VCC=24V	—	18	22	
Output ON resistance	Ronh_h	OUP,OVP,OWP	IOUT=50mA	—	17	34	Ω
	Ronh_l		IOUT=-50mA	—	17	34	Ω
	Ronl_h	OUN,OVN,OWN	IOUT=50mA	—	17	34	Ω
	Ronl_l		IOUT=-50mA	—	17	34	Ω
Turn on time	Tonp	OUP,OVP,OWP, OUN,OVN, OWN	VCC=12V	—	1.5	2	μs
	Tonn		VCC=12V	—	1.5	2	
Turn off time	Toffp		VCC=12V	—	1.5	2	
	Toffn		VCC=12V	—	1.5	2	
responsiveness	—	—	OSC=8MHz	0.3	—	12	μs
Dead time	—	—		0.25	0.5	1.2	μs
Earth fault over current detection	Losh	OUP,OVP,OWP	—	90	155	310	mA
supply fault over current detection	Losl	OUN,OVN,OWN	—	90	130	310	mA
Earth fault over current detection	Losh		—	90	130	310	mA

9.11 TSD characteristics

VCC = 7 to 18 V, Ta = -40 to 125°C

Characteristics	Symbol	Applicable Pin	Test Condition	Rating			Unit
				MIN	TYP	MAX	
Detection temperature	TSD-h	—	Note	155	165	175	°C
Detection release temperature	TSD-l	—	Note	145	155	165	°C
HYS width	—	—	Note	—	10	—	°C

Note : Shipping test is not done at actual rating temperature.

9.12 AOVER characteristics

VCC = 7 to 18 V, Ta = -40 to 125°C

Characteristics	Symbol	Applicable Pin	Test Condition	Rating			Unit
				MIN	TYP	MAX	
Input voltage range	Vin1		—	0	—	VREG	V
Input bias current	Ibias1	AMPP,AMP M	AMPP=0V, AMPM-AMPO short	-2	-0.2	—	μA
	Ibias2		AMPM=0V, AMPP=2V	-2	-0.2	—	μA
Input offset current	Ioffset		AMPP-AMPM	-0.3	0	0.4	μA
Input offset voltage	Voffset		1 stage amplifier, 40 times	-4.5	—	4.5	mV
AMP output voltage	VampH1	AMPO	AMPP=0V, AMPM=2.5V, IOUT=0mA	—	—	0.05	V
	VampH2		AMPP=0V, AMPM=2.5V, IOUT=2mA	—	—	1.5	
	VampL1		AMPP=2.5V, AMPM=0V, IOUT=0mA	VREG - 2	—	—	
	VampL2		AMPP=2.5V, AMPM=0V, IOUT=-2mA	VREG - 2.5	—	—	
	VampH3		AMPP=0V, AMPM=5V, IOUT=0mA	—	—	0.05	
	VampL3		AMPP=5V, AMPM=0V, IOUT=0mA	VREG - 2	—	—	
AMP slew rate	Sretrate4 0		1 stage amplifier 40 times	0.3	—	6	V/μs
				-5	—	-0.1	
AMP response	Res40		—	—	1	3	μs
AMP response	Res	CSAMP LA	Output open	—	1	500	μs
Input current1	Iin	CSAMP	Vin=0V, ASW=OFF	-1	—	—	μA
			Vin=VREG, ASW=OFF	—	—	1	μA
Input current2	Iin-h2	ASHUT CLMT	VIN=5V, VDD=5V	5	10	22	μA
L input current2	Iin-l2		VIN=0V, VDD=5V	-10	0	11	μA
LA output current	RLAin	LA	CSAMP = 1V, LA = 2V	5	10	22	μA
			CSAMP = 2V, LA = 1V	-20	-10	-2	μA
H output voltage	Voh	OVD	IO = -3mA	VDD-0.8	VDD-0.6	—	V
L output voltage	Vol		IO = 3mA	—	0.6	0.8	V

9.13 AD converter characteristics

VCC = 7 to 18 V, Ta = -40 to 125°C

Characteristics	Symbol	Applicable Pin	Test Condition	Rating			Unit
				MIN	TYP	MAX	
VCC over voltage detection	AD2h	VCC	—	18.2	20	22.5	V
VCC over voltage release voltage	AD2l		—	17.7	19.5	22	V
VCC low voltage detection	Vbatl-l		—	5	5.9	7	V
VCC low voltage detection release	Vbatl-h		—	6	6.4	7.5	V

9.14 Input buffer characteristics

VCC = 7 to 18 V, Ta = -40 to 125°C

Characteristics	Symbol	Applicable Pin	Test Condition	Rating			Unit
				MIN	TYP	MAX	
H input voltage	Vin-h	DT0 DT1 CW/CCW ENA SEL0 to SEL3	—	0.8*VDD	—	—	V
L input voltage	Vin-l		—	—	—	0.2*VDD	
Input current H	Iin-h		VDD=5V=Vin	-10	0	11	μA
Input current L	Iin-l		VDD=5V, Vin=0V	-200	-100	-50	
Input resistance	PDR		—	—	50	—	kΩ
Input current H	Iih	TSHUT TLMT LAMAX	VREG=VDD=5V, Vin=5V	5	10	22	μA
Input current L	Iil		VREG=VDD=5V, Vin=0V	-10	0	11	
Input current H	Iih	TOVER	VREG=VDD=5V, Vin=5V	-10	0	11	μA
Input current L	Iil		VREG=VDD=5V, Vin=0V	-10	0	11	

9.15 Output buffer characteristics

VCC = 7 to 18 V, Ta = -40 to 125°C

Characteristics	Symbol	Applicable Pin	Test Condition	Rating			Unit
				MIN	TYP	MAX	
Output voltage H	VOH	OFV	VDD=5V, No load	0.95*VDD	VDD	—	V
Output voltage L	VOL			—	0	0.25	V
Output current H	IOH		VDD=5V, Vin=0V	-100	-50	-25	μA
Output current L	IOL		VDD=5V, Vin=VDD	25	50	100	μA
H output voltage	Voh	ANAO	Io=-3mA, VDD=5V	VDD-0.8	VDD-0.6	—	V
L output voltage	Vol		Io=3mA, VDD=5V	—	0.6	0.8	V
H output voltage	Voh	OVD	IO=-3mA, VDD=5V	VDD-0.8	VDD-0.6	—	V
L output voltage	Vol		IO=3mA, VDD=5V	—	0.6	0.8	V
H output voltage	Voh	DG	Io=-3mA, VDD=5V	VDD-0.8	VDD-0.6	—	V
L output voltage	Vol		Io=3mA, VDD=5V	—	0.6	0.8	V

10. Application circuit

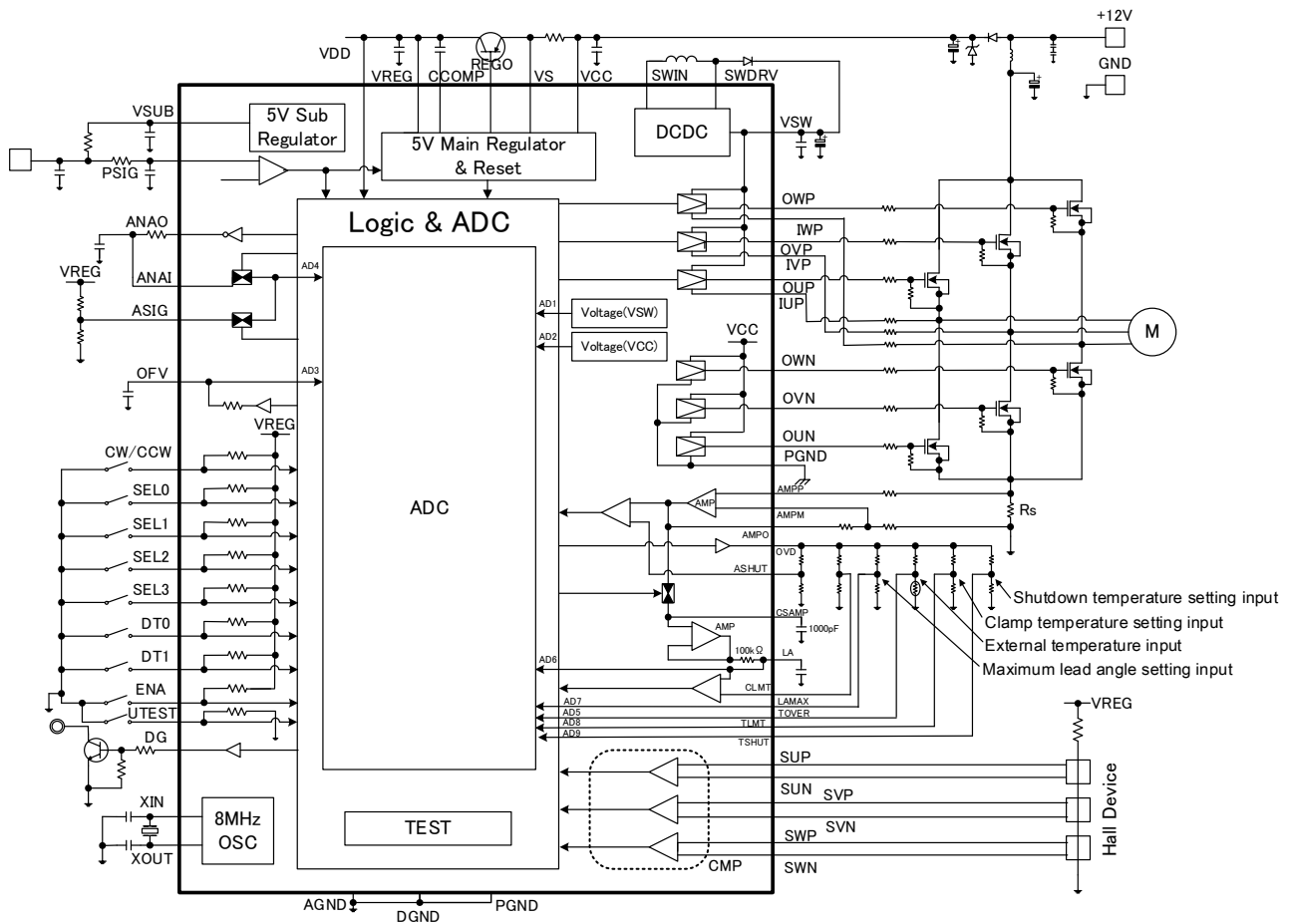

Note1 : The capacitors C1 is for absorbing disturbance noise, etc. Connect the capacitor as close to the IC as possible.

Note2 : Install the product correctly. Otherwise, it may result in break down, damage and/or deterioration to the product or equipment.

Note3 : The application circuit shown above is not intended to guarantee mass production. A thorough evaluation is required when designing an application circuit for mass production. In furnishing this application circuit example, Toshiba does not grant the use of any industrial property rights.

Note4 : Equivalent circuit may be simplified for clear-cut explanation.

11. Package

LQFP64-P-1010-0.50E
 Weight : 0.35g(Typ.)

Unit : mm

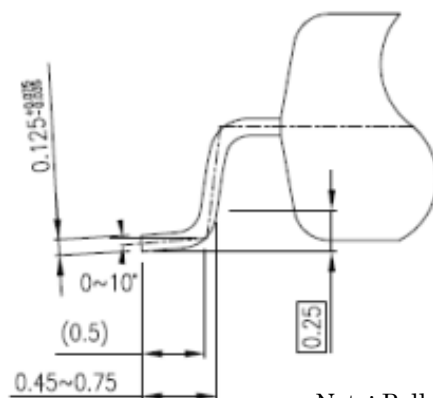
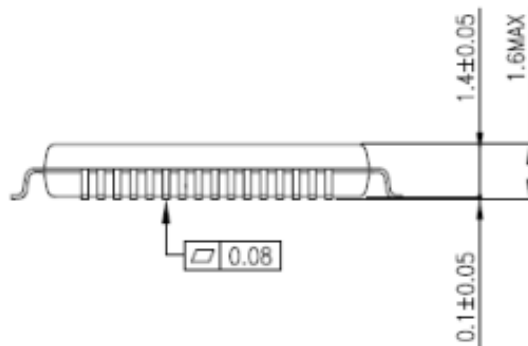
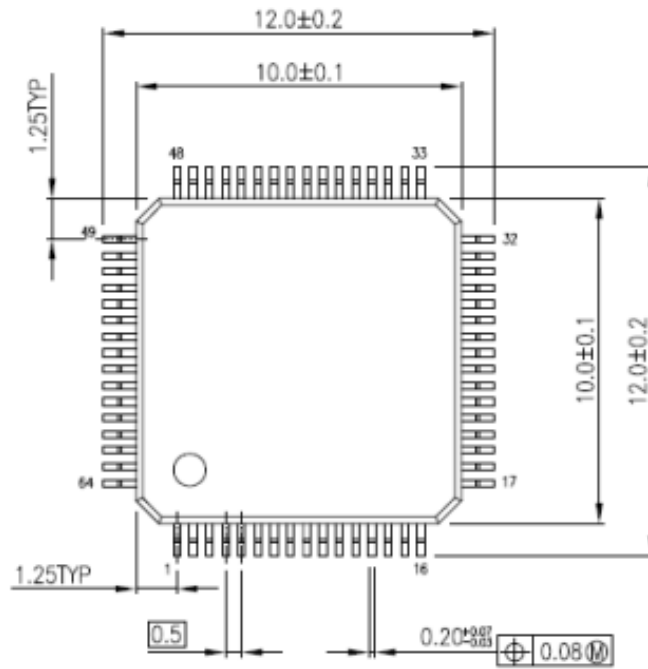

Note: Palladium plating specification

12. The important matter of written contents

- 1) Since a function is explained, the functional block / circuit / constant in a block diagram may have been omitted and simplified in part.
- 2) Since a circuit is explained, the equivalent circuit may have been omitted and simplified in part.
- 3) Since a function and operation are explained, the timing chart may have been simplified.
- 4) The example of an application circuit is a reference example, and please perform sufficient evaluation on the occasion of a mass-production design. Moreover, industrial property is not licensed.
- 5) The parts in a measurement circuit are used for the characteristic check, and don't guarantee that malfunction or failure of application apparatus do not occur.

13. Precautions-for-Use Matter

1) Absolute maximum rating is a standard which must exceed no one value of two or more rating even an instant. It cannot exceed to any of two or more rating.

When absolute maximum rating is exceeded, it may become a cause of destruction, damage, and degradation, and it may get injured [by a burst and combustion].

2) Please make a mistake in a device's carrying out a reverse difference and putting, and do not make reverse connection of plus of a power supply, and minus.

Current and power consumption may exceed absolute maximum rating, and it may not only become a cause of destruction, damage, and degradation, but they may get injured by a burst and combustion.

In addition, please do not use the device which carried out the reverse difference and turned on electricity with the put difference.

3) Please use a suitable power supply fuse so that high current does not continue flowing in generating of an over-current, or failure of IC.

IC is that may destroy owing to the unusual pulse noise etc. which are induced from the usage beyond absolute maximum rating, the mistaken wiring and wiring, or load, and high current continues flowing into IC as a result, and may result in emitting smoke and ignition.

In order to make influence into the minimum supposing the outflow ON of the high current in destruction, a proper setup of the capacity of a fuse, pre-arcing time, an insertion circuit position, etc. is needed.

4) When there is inductive load like coils, such as a drive of a motor, please connect the protection circuit for preventing the malfunction or destruction of a device resulting from the incoming current at the time of ON, or the current of the cathode nature by the back electromotive force at the time of OFF. When IC breaks, it may get injured or may result in emitting smoke and ignition. Please use the stable power supply for IC in which the protection feature is built. When a power supply is unstable, the protection feature may not operate but IC may break. By destruction of IC, it may get injured or may result in emitting smoke and ignition.

5) External components (an input, a reverse feedback capacitor, etc.), such as power amplifier and a regulator Load parts (loudspeaker etc.) Please fully take selection into consideration.

When leakage current, such as an input and a reverse feedback capacitor, is large, the output DC voltage of IC becomes large.

If this output voltage is connected to a loudspeaker with low input withstand voltage, it may result in emitting smoke and ignition of a loudspeaker by generating of an over-current, or failure of IC.

(The IC itself may fume and ignite) BTL (Bridge Tied Load) which inputs especially output DC voltage into a loudspeaker directly Consideration is required when using IC of a connection system.

6) An over-current detector circuit does not necessarily protect IC by any cases. Please cancel [operation] an over-current state promptly. When absolute maximum rating is exceeded, according to directions for use or a situation, the over-current detector circuit may not operate normally, or IC may break, before operating.

Moreover, after operation, when an over-current continues flowing for a long time, depending on directions for use or a situation, IC may break by generation of heat etc.

7) An overheating detector circuit (TSD) does not necessarily protect IC by any cases. Please cancel [operation] an overheating state promptly. When it is used exceeding absolute maximum rating, according to directions or a situation, the overheating detector circuit may not operate normally, or IC may break, before operating.

8) On the occasion of the use of IC of the power amplifier of a heat dissipation design, a regulator, a driver, etc. in which high current flows out and carries out ON, please perform suitable heat dissipation and design to become below regulation welding temperature (T_j). At the time of ordinary use, these ICs carry out self-heating. When IC heat dissipation design is insufficient, a fall, characteristic degradation, and destruction of the life of IC may occur.

Moreover, please also take into consideration and design the influence on the parts currently used on the outskirts with generation of heat of IC.

9) Since current flows a motor into a power supply from a motor under the influence of the back electromotive force of a motor when an inversion, a stop, and a sudden slowdown are performed, back electromotive force has a possibility that the power supply terminal of IC and an output terminal may go up more than rating, when the Sink capability of a power supply is small.

RESTRICTIONS ON PRODUCT USE

Toshiba Corporation and its subsidiaries and affiliates are collectively referred to as "TOSHIBA".

Hardware, software and systems described in this document are collectively referred to as "Product".

- TOSHIBA reserves the right to make changes to the information in this document and related Product without notice.
- This document and any information herein may not be reproduced without prior written permission from TOSHIBA. Even with TOSHIBA's written permission, reproduction is permissible only if reproduction is without alteration/omission.
- Though TOSHIBA works continually to improve Product's quality and reliability, Product can malfunction or fail. Customers are responsible for complying with safety standards and for providing adequate designs and safeguards for their hardware, software and systems which minimize risk and avoid situations in which a malfunction or failure of Product could cause loss of human life, bodily injury or damage to property, including data loss or corruption. Before customers use the Product, create designs including the Product, or incorporate the Product into their own applications, customers must also refer to and comply with (a) the latest versions of all relevant TOSHIBA information, including without limitation, this document, the specifications, the data sheets and application notes for Product and the precautions and conditions set forth in the "TOSHIBA Semiconductor Reliability Handbook" and (b) the instructions for the application with which the Product will be used with or for. Customers are solely responsible for all aspects of their own product design or applications, including but not limited to (a) determining the appropriateness of the use of this Product in such design or applications; (b) evaluating and determining the applicability of any information contained in this document, or in charts, diagrams, programs, algorithms, sample application circuits, or any other referenced documents; and (c) validating all operating parameters for such designs and applications. **TOSHIBA ASSUMES NO LIABILITY FOR CUSTOMERS' PRODUCT DESIGN OR APPLICATIONS.**
- **PRODUCT IS NEITHER INTENDED NOR WARRANTED FOR USE IN EQUIPMENTS OR SYSTEMS THAT REQUIRE EXTRAORDINARILY HIGH LEVELS OF QUALITY AND/OR RELIABILITY, AND/OR A MALFUNCTION OR FAILURE OF WHICH MAY CAUSE LOSS OF HUMAN LIFE, BODILY INJURY, SERIOUS PROPERTY DAMAGE AND/OR SERIOUS PUBLIC IMPACT ("UNINTENDED USE").** Except for specific applications as expressly stated in this document, Unintended Use includes, without limitation, equipment used in nuclear facilities, equipment used in the aerospace industry, and lifesaving and / or life supporting medical equipment. **IF YOU USE PRODUCT FOR UNINTENDED USE, TOSHIBA ASSUMES NO LIABILITY FOR PRODUCT.** For details, please contact your TOSHIBA sales representative or contact us via our website.
- Do not disassemble, analyze, reverse-engineer, alter, modify, translate or copy Product, whether in whole or in part.
- Product shall not be used for or incorporated into any products or systems whose manufacture, use, or sale is prohibited under any applicable laws or regulations.
- The information contained herein is presented only as guidance for Product use. No responsibility is assumed by TOSHIBA for any infringement of patents or any other intellectual property rights of third parties that may result from the use of Product. No license to any intellectual property right is granted by this document, whether express or implied, by estoppel or otherwise.
- **ABSENT A WRITTEN SIGNED AGREEMENT, EXCEPT AS PROVIDED IN THE RELEVANT TERMS AND CONDITIONS OF SALE FOR PRODUCT, AND TO THE MAXIMUM EXTENT ALLOWABLE BY LAW, TOSHIBA (1) ASSUMES NO LIABILITY WHATSOEVER, INCLUDING WITHOUT LIMITATION, INDIRECT, CONSEQUENTIAL, SPECIAL, OR INCIDENTAL DAMAGES OR LOSS, INCLUDING WITHOUT LIMITATION, LOSS OF PROFITS, LOSS OF OPPORTUNITIES, BUSINESS INTERRUPTION AND LOSS OF DATA, AND (2) DISCLAIMS ANY AND ALL EXPRESS OR IMPLIED WARRANTIES AND CONDITIONS RELATED TO SALE, USE OF PRODUCT, OR INFORMATION, INCLUDING WARRANTIES OR CONDITIONS OF MERCHANTABILITY, FITNESS FOR A PARTICULAR PURPOSE, ACCURACY OF INFORMATION, OR NONINFRINGEMENT.**
- Do not use or otherwise make available Product or related software or technology for any military purposes, including without limitation, for the design, development, use, stockpiling or manufacturing of nuclear, chemical, or biological weapons or missile technology products (mass destruction weapons). Product and related software and technology may be controlled under the applicable export laws and regulations including, without limitation, the Japanese Foreign Exchange and Foreign Trade Law and the U.S. Export Administration Regulations. Export and re-export of Product or related software or technology are strictly prohibited except in compliance with all applicable export laws and regulations.
- Please contact your TOSHIBA sales representative for details as to environmental matters such as the RoHS compatibility of Product. Please use Product in compliance with all applicable laws and regulations that regulate the inclusion or use of controlled substances, including without limitation, the EU RoHS Directive. **TOSHIBA ASSUMES NO LIABILITY FOR DAMAGES OR LOSSES OCCURRING AS A RESULT OF NONCOMPLIANCE WITH APPLICABLE LAWS AND REGULATIONS.**

TOSHIBA ELECTRONIC DEVICES & STORAGE CORPORATION

<https://toshiba.semicon-storage.com/>

Mouser Electronics

Authorized Distributor

Click to View Pricing, Inventory, Delivery & Lifecycle Information:

[Toshiba:](#)

[TB9080FG](#)