CR95HF RF transceiver board tuning circuit with EMI filter

Introduction

The purpose of this application note is to describe the antenna tuning circuit of the CR95HF RF transceiver board embedding the EMI filter and delivered with the M24LR-DISCOVERY kit.

It explains how to use the CR95HF EMI FILTER CALCULATION.xlsm tool (STSW-95HF003), which is a separate Excel sheet available on www.st.com.

The different impedance matching calculation steps are presented.

[Table 1](#) lists the tool and software concerned by this application note.

Table 1. Applicable tool and software

Type	Part numbers / Product categories
Evaluation Tools	M24LR-DISCOVERY
Software	STSW-95HF003

Contents

- 1 CR95HF tuning circuit with an EMI filter 4**
 - 1.1 Description 4
 - 1.2 Designing a tuning circuit without an EMI filter 5
 - 1.3 Designing a tuning circuit with an EMI filter 6

- 2 Calculation explanations 7**

- 3 Calculation tool 9**
 - 3.1 Tuning circuit calculation 10
 - 3.2 Input impedance curves 12
 - 3.3 Circuit voltages 13
 - 3.4 Magnetic field vs distance 14

- 4 Practical tuning circuit design 15**
 - 4.1 Step by step procedure 15
 - 4.2 Input impedance choice 15

- 5 Revision history 16**

List of figures

Figure 1.	CR95HF tuning circuit with an EMI filter	4
Figure 2.	Impedance matching without an EMI filter	5
Figure 3.	Impedance matching with an EMI filter	6
Figure 4.	CR95HF + EMI filter equivalent generator	7
Figure 5.	Circuit for tuning calculation	8
Figure 6.	Tuning circuit calculation	10
Figure 7.	Antenna circuit input impedance	12
Figure 8.	Voltage calculation at various locations	13
Figure 9.	Magnetic field (H) versus distance	14

1 CR95HF tuning circuit with an EMI filter

1.1 Description

To limit the spurious emission at high frequencies, the CR95HF RF transceiver board embeds a second order low-pass filter (so called EMI filter).

The EMI filter is placed between the CR95HF and the antenna tuning circuit, as you can see on [Figure 1](#). Its goal is to attenuate the frequencies above 13.56 MHz.

Figure 1. CR95HF tuning circuit with an EMI filter

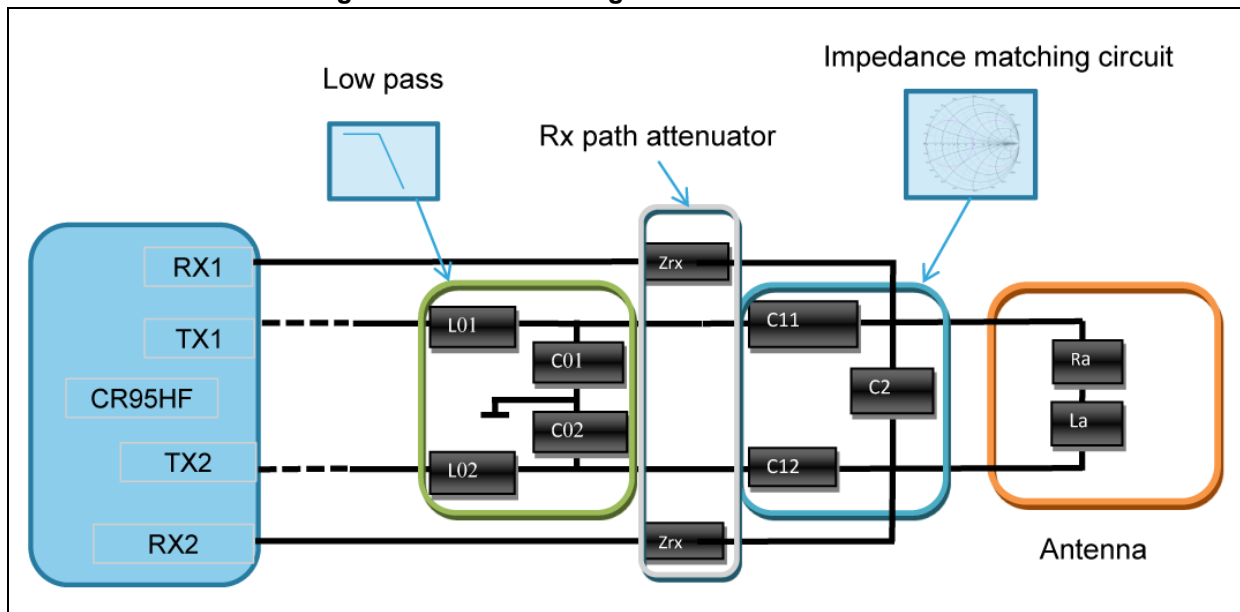

1.2 Designing a tuning circuit without an EMI filter

Designing a tuning circuit without an EMI filter for the CR95HF consists in calculating the C11, C12 and C2 capacitor values, so that the input impedance (Z_{in1}) of the circuit, seen from TX1 and TX2, matches the complex conjugate of the CR95HF output impedance (see AN3394).

Figure 2. Impedance matching without an EMI filter

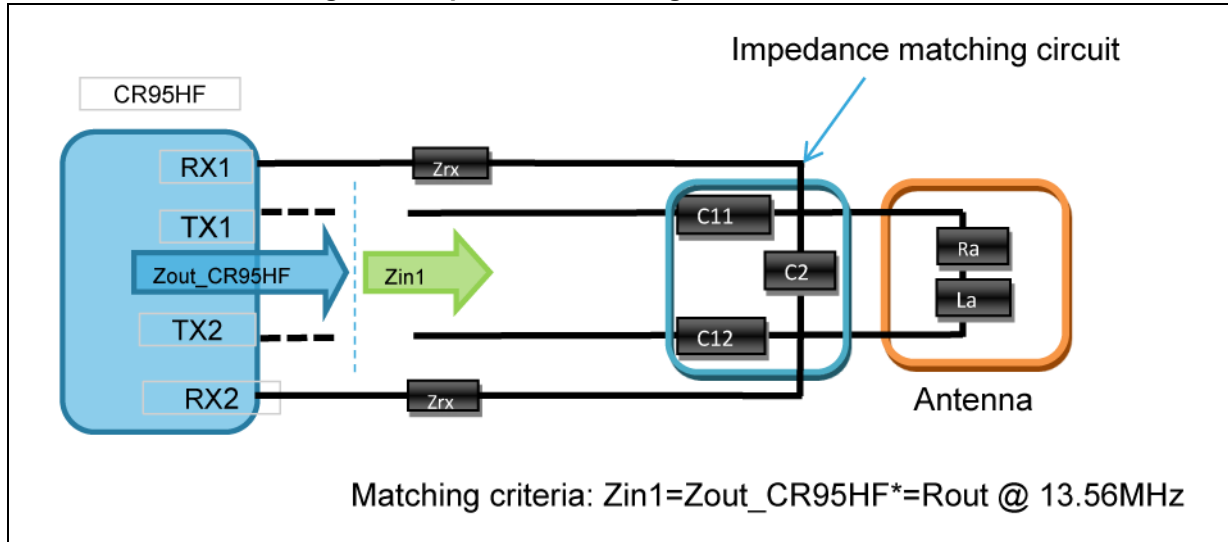

1.3 Designing a tuning circuit with an EMI filter

Designing a tuning circuit with an EMI filter for the CR95HF follows the same procedure except that C11, C12 and C2 are calculated so that the tuning circuit input impedance (Z_{in2}) matches the complex conjugate output impedance of the new RF generator, which is made of the CR95HF and its EMI filter (see [Figure 3](#)).

Figure 3. Impedance matching with an EMI filter

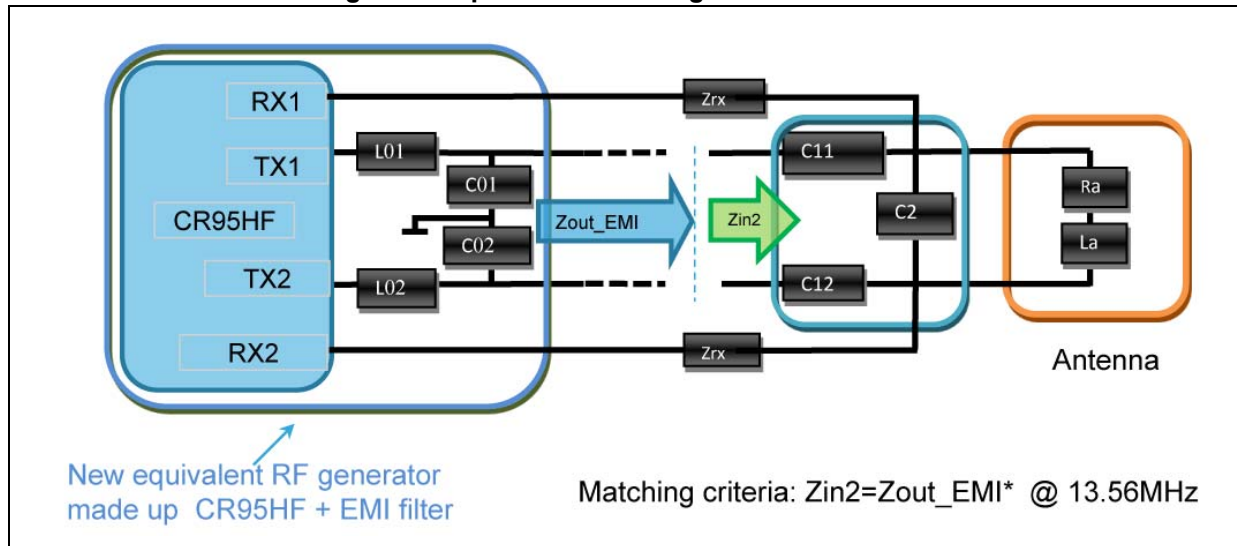

When the matching criteria is satisfied, the input impedance (Z_{in}) of the circuit seen from TX1-TX2 also satisfies the condition $Z_{in} = R_{out}$, and a maximum power transfer occurs between the CR95HF and the antenna.

2 Calculation explanations

The CR95HF + EMI filter equivalent circuit comes after some simple transformation (see [Figure 4](#)).

Figure 4. CR95HF + EMI filter equivalent generator

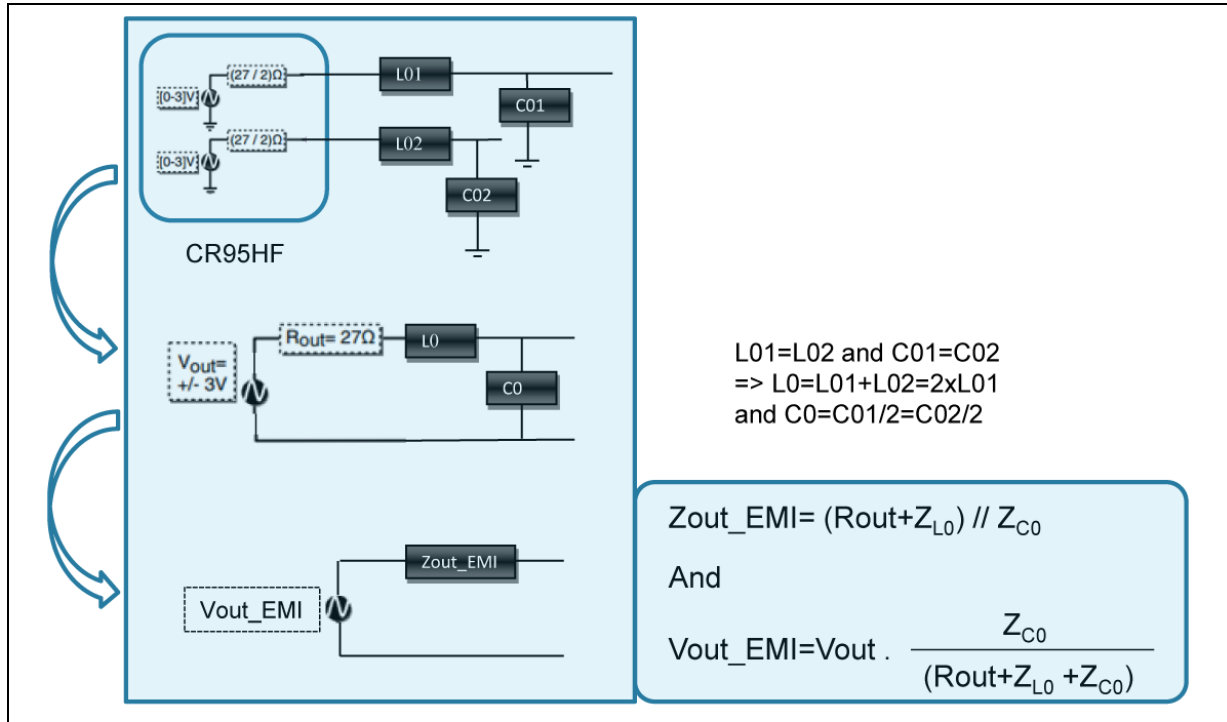

The cut-off frequency of the EMI filter defined by $f_c = \frac{1}{2\pi\sqrt{(L0 \times C0)}}$ is chosen above 14 MHz.

It is recommended to use an inductance wired on ferrite cores. However, to maximize the EMI performance of the circuit on the CR95HF RF transceiver board, the wired inductance has been replaced by a Würth Elektronik ferrite bead EMI suppressor (ref. 742792042). Its impedance at 13.56 MHz is 653 nH in series with 2 Ω. Above 200 MHz, it behaves as a pure resistor to suppress spurious emission.

Among the available standard SMD ceramic capacitor values, C01 and C02 have been chosen to 180 pF.

The EMI filter cut-off frequency is:

$$f_c = \frac{1}{2\pi\sqrt{(L0 \times C0)}} = \frac{1}{2\pi\sqrt{(2 \times 653nH) \times \left(\frac{180pF}{2}\right)}} = 14.6MHz$$

The CR95HF receiving path RX1-RX2 input impedance $Z_{RX_CR95HF} = 22pF // 80 k\Omega$.

After replacing the RX path by its impedance, the circuit becomes as in [Figure 5](#).

Figure 5. Circuit for tuning calculation

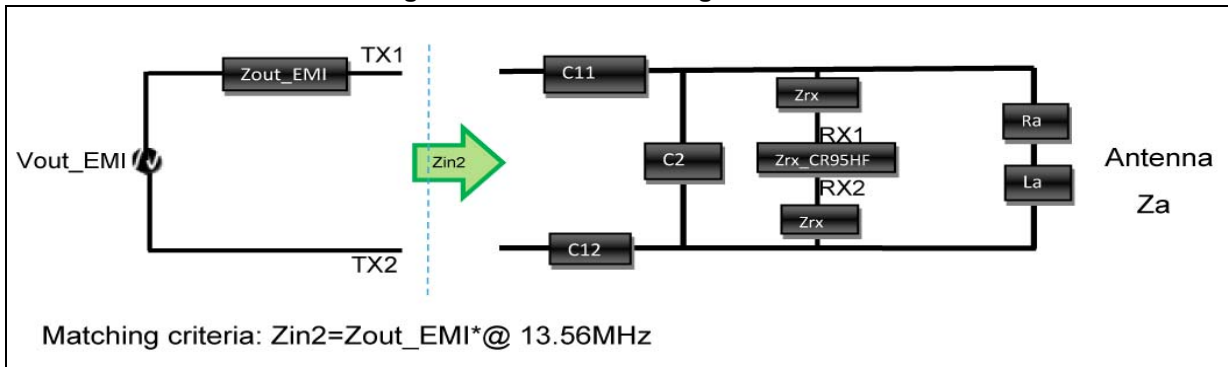

Assuming $C_{11} = C_{12} = C_1$, the resulting equation is:

$$Z_{in2} = \frac{C_1}{2} + (C_2 \parallel (2Z_{rx} + Z_{rx_CR95HF}) \parallel Z_a)$$

Solving the Impedance matching criteria $Z_{in2} = Z_{out_EMI}^*$ allows you to find the values for $C_{11} = C_{12}$ and C_2 .

This calculation is done using the CR95HF EMI FILTER CALCULATION.xlsm spreadsheet. Connect to www.st.com to download this Excel calculation tool.

3 Calculation tool

The CR95HF EMI FILTER CALCULATION.xlsm spreadsheet includes 4 tabs:

1. Tuning circuit calculation
2. Input impedance curves
3. Circuit voltages
4. Magnetic fields vs distance

This tool allows you to:

- Calculate the ideal tuning capacitance C11, C12 and C2 based on the system components (select the 1st tab).
- Calculate the theoretical circuit input impedance according to the system parameters and custom tuning capacitance values (select the 1st tab)
 - This feature lets you use tuning capacitance values different from the ideal values, and check the impact on the input impedance.
 - In combination with the impedance curve given in the 2nd tab, this feature lets you adjust the tuning capacitance values on the Printed circuit board (PCB).
- Trace the theoretical circuit input impedance curve (magnitude and phase) versus the frequency, according to the custom tuning capacitance values defined in the 1st tab.
- Trace the voltage amplitude at different points of the circuit according to the custom tuning capacitance value (select the 3rd tab).
- Estimate the magnetic field strength generated by the reader according to the system parameters of the system (select the 4th tab).

3.1 Tuning circuit calculation

Select the 1st tab of CR95HF EMI FILTER CALCULATION.xlsm spreadsheet:

- Tuning circuit calculation

Various configurations can be calculated, as you can seen on [Figure 6](#).

Figure 6. Tuning circuit calculation

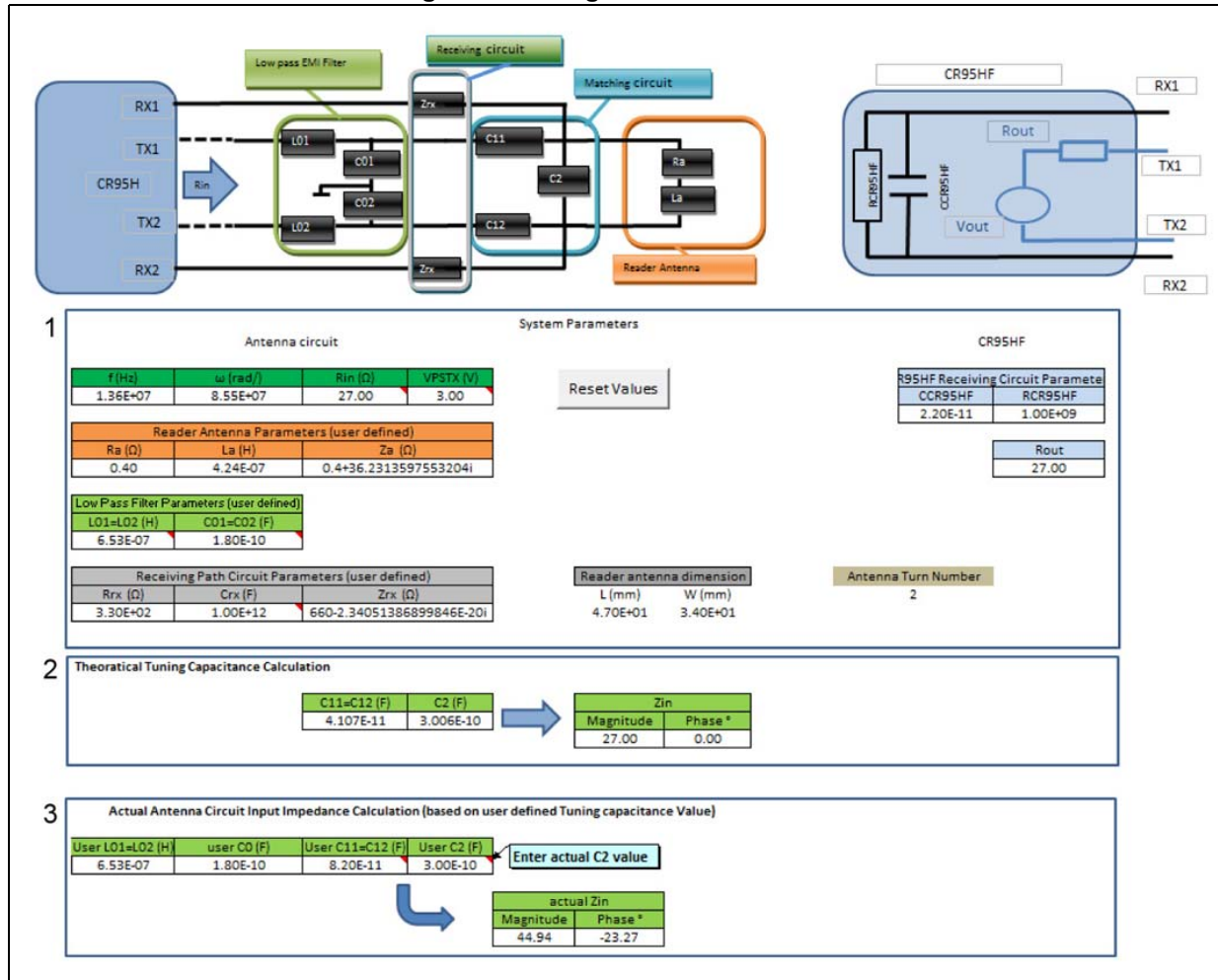

1. CR95HF and User defined system parameters.
2. Ideal tuning capacitance calculation.
3. Input impedance calculation based on user defined tuning capacitances.

EMI filter

It is possible to calculate the tuning circuit without the EMI filter by simply choosing $L01 = L02 = 0$ and $C01 = C02 = 10^{-40}$ (simulating an open circuit)

Receiving path

The calculation tool allows to use a resistor in series with a capacitor in the receiving path, by choosing:

- $Crx = 10^{12}$
The calculation is made with a resistor only in the receiving path.
- $Rrx = 0$
The calculation is made with a series capacitor only in the receiving path.

3.2 Input impedance curves

Select the 2nd tab of CR95HF EMI FILTER CALCULATION.xlsm spreadsheet:

- Input impedance curves

Based on the tuning capacitance values chosen in [Figure 6](#) of the calculation tool, the circuit input impedance is calculated over the frequency (F).

The example in [Figure 7](#) shows the input impedance calculated with the CR95HF RF transceiver board tuning capacitances.

Figure 7. Antenna circuit input impedance

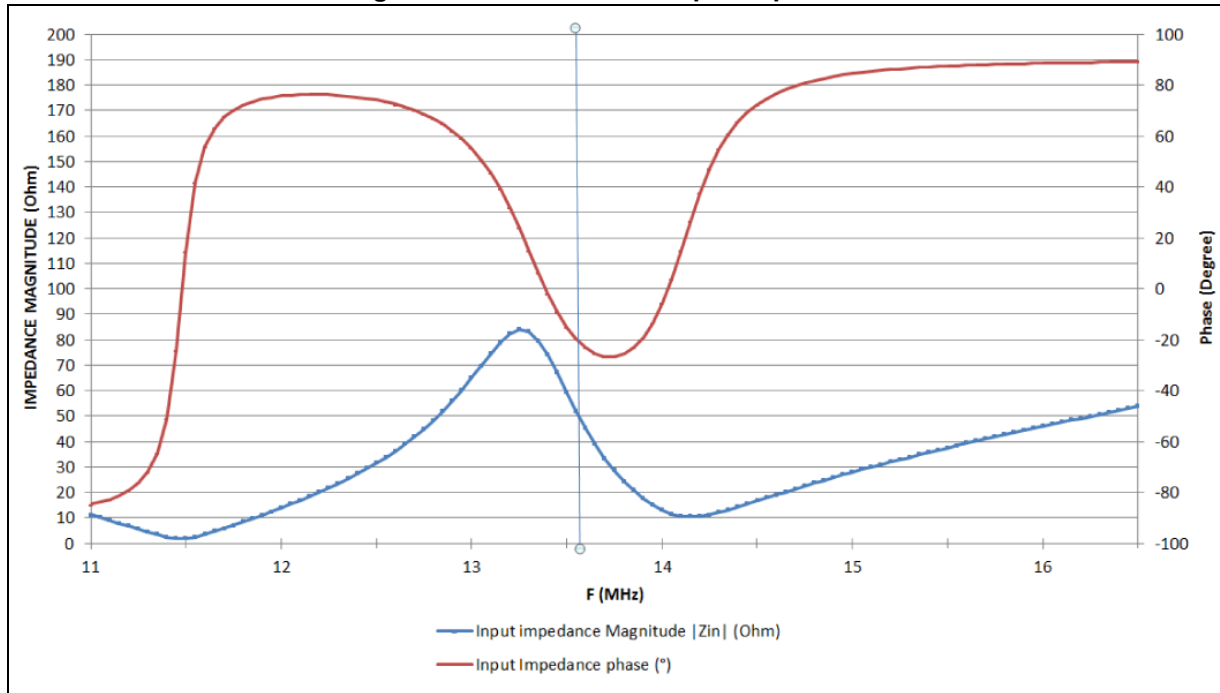

3.3 Circuit voltages

Select the 3rd tab of CR95HF EMI FILTER CALCULATION.xlsm spreadsheet:

- Circuit voltages

Based on the tuning capacitance values chosen of the calculation tool, voltages at various locations in the circuit are calculated (see [Figure 8](#)).

This feature is useful to estimate the RX path attenuation which is necessary to limit VRX1-RX2 below 7 V.

Figure 8. Voltage calculation at various locations

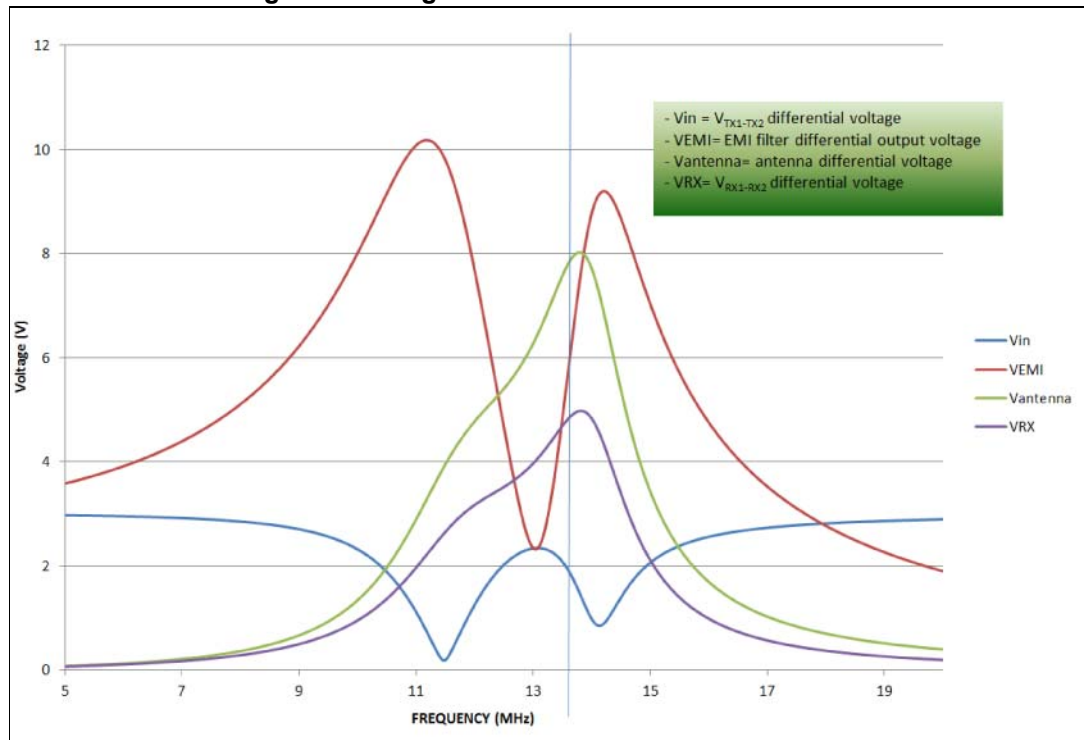

3.4 Magnetic field vs distance

Select the 4th tab of CR95HF EMI FILTER CALCULATION.xlsm spreadsheet:

- Magnetic field vs distance.

Based on the differential antenna voltage Vantenna from the 3rd tab and the antenna parameters (dimensions and number of turns) chosen in the 1st tab, an estimation of the generated magnetic field is calculated in the 4th tab (see [Figure 9](#)).

Figure 9. Magnetic field (H) versus distance

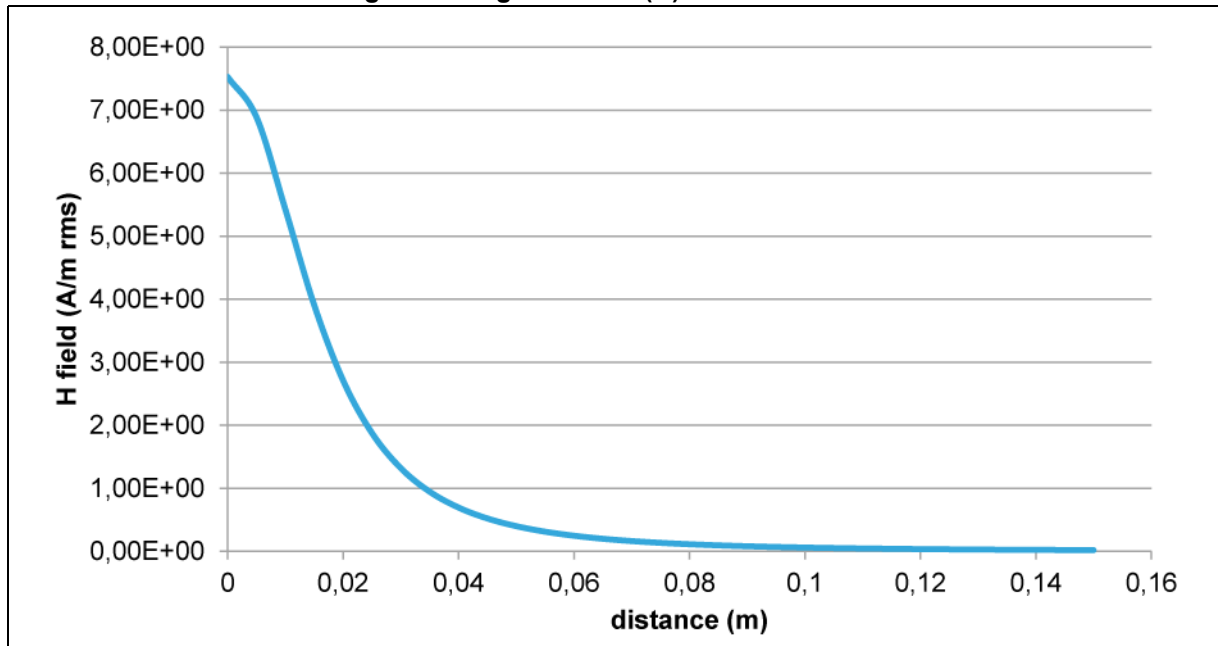

Note: For information only.

4 Practical tuning circuit design

4.1 Step by step procedure

Four steps are needed:

Step 1

Measure the CR95HF antenna impedance on the PCB.

Step 2

Estimate the C11, C12, C2 and ZRX impedance values using the CR95HF EMI filter calculation tool. Mount the component values from step 2 on the PCB.

Step 3

- a) Without powering the board, measure the circuit input impedance between TX1 and TX2 using a network analyzer or an impedance analyzer. Tune the C11, C12 and C2 capacitance values, if necessary.
- b) As a design trick, the tuning frequency can be adjusted using C2, and the impedance magnitude can be adjusted using C11/C12. This can be verified using the impedance curve feature of the CR95HF EMI filter calculation tool.
- c) Power up the board and activate the RF generation (this can be achieved by sending a Protocol_Select command to the CR95HF).
- d) Measure the DC voltage in the ST_R0 pin: adjust the ZRX component value to limit the voltage measured on ST_R0 below 7 V.
- e) After powering down the PCB, check the input impedance and adjust it with C11, C12 and C2, if necessary.

Step 4

Check the RF performance with a tag.

4.2 Input impedance choice

Because of the reader antenna detuning occurring when the tag is very close to the reader, some communication hole can appear at very short distance.

To overcome this, it is appropriate to choose an input impedance higher than the CR95HF output impedance: for instance, to maintain the energy harvesting capability of the C95HF RF transceiver board, the input impedance of the antenna circuit has been set to 50 Ω .

This value has a minor impact on the CR95HF to power up the tag at a long distance from the reader antenna, maintaining a magnetic field strength level sufficient to guarantee the energy harvesting function of the M24LRXXE-R at a short distance from the reader antenna.

5 Revision history

Table 1. Document revision history

Date	Revision	Changes
29-Aug-2013	1	Initial release.

Please Read Carefully:

Information in this document is provided solely in connection with ST products. STMicroelectronics NV and its subsidiaries ("ST") reserve the right to make changes, corrections, modifications or improvements, to this document, and the products and services described herein at any time, without notice.

All ST products are sold pursuant to ST's terms and conditions of sale.

Purchasers are solely responsible for the choice, selection and use of the ST products and services described herein, and ST assumes no liability whatsoever relating to the choice, selection or use of the ST products and services described herein.

No license, express or implied, by estoppel or otherwise, to any intellectual property rights is granted under this document. If any part of this document refers to any third party products or services it shall not be deemed a license grant by ST for the use of such third party products or services, or any intellectual property contained therein or considered as a warranty covering the use in any manner whatsoever of such third party products or services or any intellectual property contained therein.

UNLESS OTHERWISE SET FORTH IN ST'S TERMS AND CONDITIONS OF SALE ST DISCLAIMS ANY EXPRESS OR IMPLIED WARRANTY WITH RESPECT TO THE USE AND/OR SALE OF ST PRODUCTS INCLUDING WITHOUT LIMITATION IMPLIED WARRANTIES OF MERCHANTABILITY, FITNESS FOR A PARTICULAR PURPOSE (AND THEIR EQUIVALENTS UNDER THE LAWS OF ANY JURISDICTION), OR INFRINGEMENT OF ANY PATENT, COPYRIGHT OR OTHER INTELLECTUAL PROPERTY RIGHT.

ST PRODUCTS ARE NOT AUTHORIZED FOR USE IN WEAPONS. NOR ARE ST PRODUCTS DESIGNED OR AUTHORIZED FOR USE IN: (A) SAFETY CRITICAL APPLICATIONS SUCH AS LIFE SUPPORTING, ACTIVE IMPLANTED DEVICES OR SYSTEMS WITH PRODUCT FUNCTIONAL SAFETY REQUIREMENTS; (B) AERONAUTIC APPLICATIONS; (C) AUTOMOTIVE APPLICATIONS OR ENVIRONMENTS, AND/OR (D) AEROSPACE APPLICATIONS OR ENVIRONMENTS. WHERE ST PRODUCTS ARE NOT DESIGNED FOR SUCH USE, THE PURCHASER SHALL USE PRODUCTS AT PURCHASER'S SOLE RISK, EVEN IF ST HAS BEEN INFORMED IN WRITING OF SUCH USAGE, UNLESS A PRODUCT IS EXPRESSLY DESIGNATED BY ST AS BEING INTENDED FOR "AUTOMOTIVE, AUTOMOTIVE SAFETY OR MEDICAL" INDUSTRY DOMAINS ACCORDING TO ST PRODUCT DESIGN SPECIFICATIONS. PRODUCTS FORMALLY ESCC, QML OR JAN QUALIFIED ARE DEEMED SUITABLE FOR USE IN AEROSPACE BY THE CORRESPONDING GOVERNMENTAL AGENCY.

Resale of ST products with provisions different from the statements and/or technical features set forth in this document shall immediately void any warranty granted by ST for the ST product or service described herein and shall not create or extend in any manner whatsoever, any liability of ST.

ST and the ST logo are trademarks or registered trademarks of ST in various countries.

Information in this document supersedes and replaces all information previously supplied.

The ST logo is a registered trademark of STMicroelectronics. All other names are the property of their respective owners.

© 2013 STMicroelectronics - All rights reserved

STMicroelectronics group of companies

Australia - Belgium - Brazil - Canada - China - Czech Republic - Finland - France - Germany - Hong Kong - India - Israel - Italy - Japan - Malaysia - Malta - Morocco - Philippines - Singapore - Spain - Sweden - Switzerland - United Kingdom - United States of America

www.st.com

