

Pressure regulator: Model 20289, 1669, 1941, 25155, 25148, 26278

Intended for Propane - Butane

Before initial use of the pressure regulator, check that the technical information stamped on the label is compatible with the connecting equipment.

Before installation to the gas cylinder, always make sure there is a PVC sealing placed correctly on the regulator. Check that all joining surfaces, sealing, connectors as well as the nut of regulator are not damaged.

Connect nut of regulator (thread: W21,8 x 1/4LH or G3/8LH) to the shut of valve outlet and tighten by means of spanner 30 mm (19mm).

Hoses connecting a regulator, (valve SBS) to the appliance must be screwed on the outlet G3/8LH and tightened by means of spanner (19mm).

Warning: Do not rotate with the regulator while connecting the hose; regulator must be held in vertical position (by means of spanner 15-17mm).

If there are found any production imperfections which are approved by the manufacturer by product analyzes, the product may be exchanged based on valid warranty. This warranty is valid for two years from the date of manufacture, stamped on label or regulator body. The warranty is lost if the regulator is damaged intentionally, by negligence or due to incorrect installation.

In accordance with European standards PR EN 12864, the regulator must be withdrawn from service after ten years from date of manufacture that is stamped on its label or body. The regulator must be exchanged without exceptions if operational or not.

Warning: Failure of these operational procedures might be dangerous.

Connection:

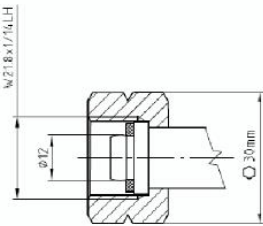
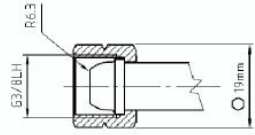
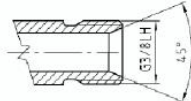
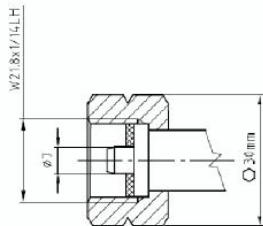
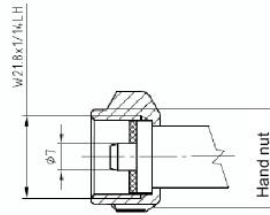
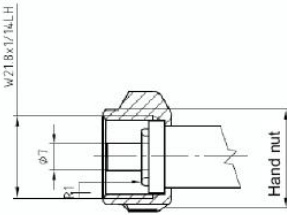
<p>Connection according to DIN 477-1</p>  <p>ČR, SR, PL, SVE, GER, A</p>	<p>Connection for 425 g PB cylinder</p> 	<p>Outlet connection according to DIN EN 560</p> 
<p>Connection according to DIN 4811-2</p>  <p>Germany - small cylinder (upto 33kg)</p>	<p>Connection according to DIN 4811 - 2 with hand nut</p>  <p>Germany - small cylinder (upto 33kg)</p>	<p>Connection according to DIN 477-2</p>  <p>Germany, Austria - small cylinder (upto 33 kg)</p>