

# Digital Proximity and Ambient Light Sensor in Small Aperture

## Data Sheet

### Description

The Broadcom<sup>®</sup> APDS-9922-001 provides digital ambient light sensing (ALS), IR LED and a complete proximity detection system in a single 8-pin package that can be used under a small aperture of the devices' cover windows. The proximity function offers plug-and-play detection to 70 mm, thus eliminating the need for factory calibration of the end equipment or subassembly. The proximity detection feature operates well from bright sunlight to dark rooms. The wide dynamic range also allows for operation in short distance detection behind dark glass, such as a cell phone.

The ALS provides a photopic response to light intensity in low light conditions or behind a dark faceplate. The APDS-9922-001 approximates the response of the human eye providing direct read out, where the output count is proportional to ambient light level. Low-light functionality enables operation behind darkened glass. The APDS-9922-001 supports programmable hardware interrupt with hysteresis to respond to events.

The APDS-9922-001 is useful for display management by extending battery life and providing optimum viewing in diverse lighting conditions. Display panel and keyboard backlighting can account for up to 30 to 40 percent of total platform power. The ALS features are ideal for use in notebook PCs, LCD monitors, flat-panel televisions, and cell phones.

The proximity function is targeted specifically towards near-field proximity applications. In cell phones, the proximity detection can detect when users position the phone close to their ear. The device is fast enough to provide proximity information at a high repetition rate needed when answering a phone call. This provides both improved *green* power-saving capability and the added security to lock the computer when the user is not present. The addition of the micro-optics lenses within the module provide highly efficient transmission and reception of infrared energy, which lowers overall power dissipation.

### Ordering Information

Table 1 Ordering Information

Part Number	Packaging	Quantity
APDS-9922-001	Tape & Reel	5000 per reel

### Features

ALS, IR LED, and Proximity Detector in an Optical Module

- Ambient Light Sensing (ALS)
  - Light output proportional to light intensity
  - Uses optical coating technology to emulate the human eye spectral response
  - Works well under different light source conditions
  - Low light density – operation behind dark glass
  - Up to 20 bits resolution
  - Temperature compensation
  - 50 Hz/60 Hz light flicker immunity
  - Fluorescent light flicker immunity
- Proximity Detection (PS)
  - Integrated IR LED and synchronous LED driver
  - Eliminates *factory calibration* of Prox
  - Cancellation of cross-talk
  - Up to 11 bits resolution
  - Ambient light suppression
- Wide supply voltage 1.7V to 3.6V
- Power Management
  - Low active current – 80  $\mu$ A typical at 1.8V
  - Low standby current – 500 nA typical at 1.8V
- I<sup>2</sup>C Interface Compatible
  - Up to 400 kHz (I<sup>2</sup>C Fast-Mode)
  - Dedicated interrupt pin
- Small Package L3.94 mm x W2.36 mm x H1.35 mm

### Applications

- Cell phone backlight dimming
- Cell phone touch-screen disable
- Notebook/monitor security
- Automatic speakerphone enable
- Automatic menu pop-up
- Digital camera eye sensor

**DISCLAIMER** This preliminary data is provided to assist you in the evaluation of product(s) currently under development. Until Broadcom releases this product for general sales, Broadcom reserves the right to alter prices, specifications, features, capabilities, functions, release dates, and remove availability of the product(s) at anytime.

**Figure 1 Functional Block Diagram**

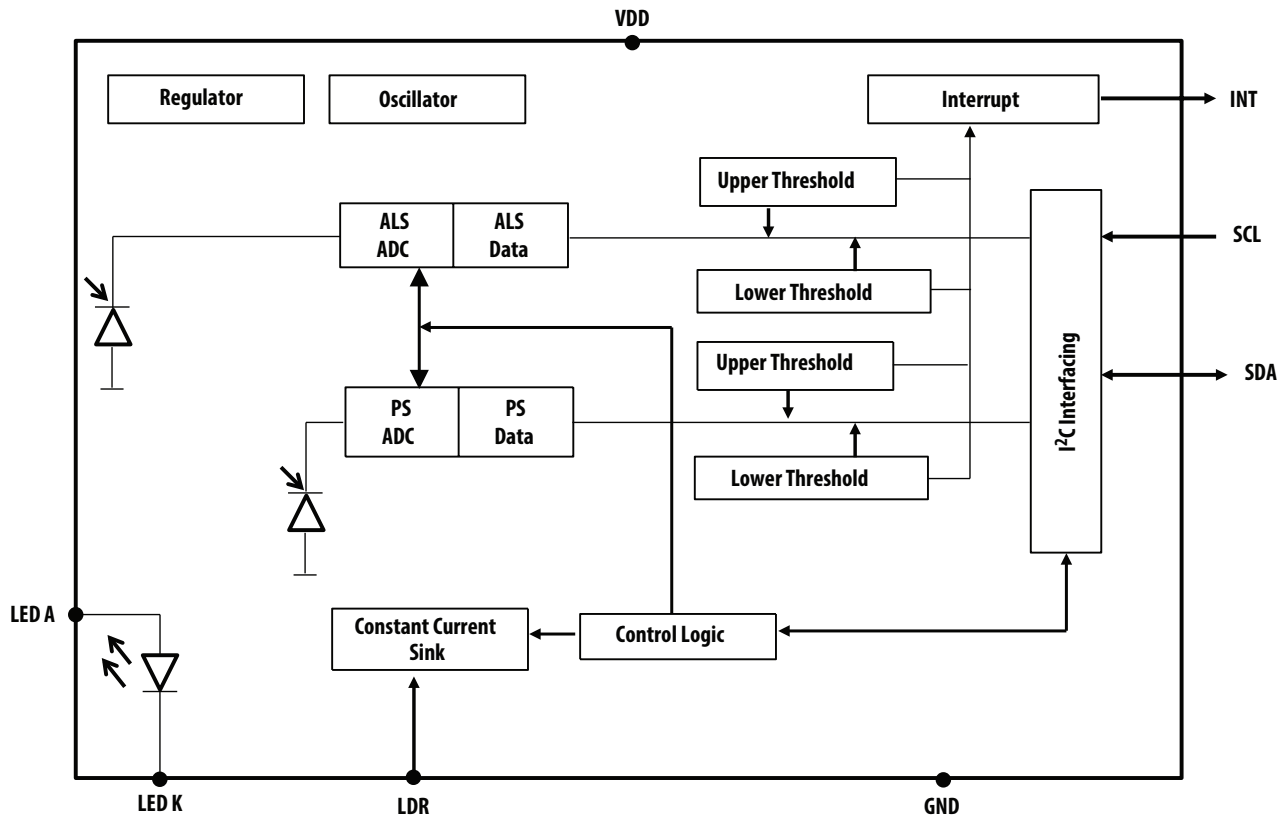

**Table 2 I/O Pins Configuration**

Pin	Name	Type	Description
1	SDA	I/O	I <sup>2</sup> C serial data I/O terminal – serial data I/O for I <sup>2</sup> C.
2	INT	O	Interrupt – open drain.
3	LDR	I	LED driver for proximity emitter – up to 125 mA, open drain.
4	LEDK	O	LED cathode, connect to LDR pin in most systems to use internal LED driver circuit.
5	LEDA	I	LED anode, connect to VLED on PCB.
6	GND	Ground	Power supply ground. All voltages are referenced to GND.
7	SCL	I	I <sup>2</sup> C serial clock input terminal – clock signal for I <sup>2</sup> C serial data.
8	VDD	Supply	Power supply voltage

**Table 3 Absolute Maximum Ratings over Operating Free-Air Temperature Range (see Note)**

Parameter	Symbol	Min.	Typ.	Max.	Unit	Conditions
Power Supply Voltage <sup>a</sup>	$V_{DD}$	—	—	3.8	V	
Digital Voltage Range		-0.5	—	3.8	V	
Storage Temperature Range	$T_{stg}$	-45	—	85	°C	

a. All voltages are with respect to GND.

**NOTE** Stresses beyond those listed under absolute maximum ratings may cause permanent damage to the device. These are stress ratings only and functional operation of the device at these or any other conditions beyond those indicated under recommended operating conditions is not implied. Exposure to absolute-maximum-rated conditions for extended periods may affect device reliability.

**Table 4 Recommended Operating Conditions**

Parameter	Symbol	Min.	Typ.	Max.	Unit	Conditions
Operating Ambient Temperature	$T_A$	-40	—	85	°C	
Supply Voltage	$V_{DD}$	1.7	—	3.6	V	
Supply Voltage Accuracy, $V_{DD}$ Total Error Including Transients		-3	—	3	%	
LED Supply Voltage	$V_{LED}$	2.5	—	4.5	V	

**Table 5 Operating Characteristics,  $V_{DD} = 2.8V$ ,  $T_A = 25^\circ C$  (unless Otherwise Noted)**

Parameter	Symbol	Min	Typ	Max	Units	Test Conditions
Supply Current	$I_{DD}$	—	110	—	$\mu A$	Active mode. (Typical 80 $\mu A$ at 1.8V)
Standby Current	$I_{STBY}$	—	—	2	$\mu A$	In Standby mode. No Active I <sup>2</sup> C Communication (Typical 500 nA at 1.8V)
SCL, SDA Input High Voltage	$V_{IH}$	1.5	—	$V_{DD}$	V	
SCL, SDA Input Low Voltage	$V_{IL}$	0	—	0.4	V	
VOL INT, SDA Output Low Voltage	$V_{OL}$	0	—	0.4	V	8 mA sink current
Leakage Current, SDA, SCL, INT Pins	$I_{LEAK}$	-5	—	5	$\mu A$	

**Table 6 ALS Characteristics,  $V_{DD} = 2.8V$ ,  $T_A = 25^\circ C$  (unless Otherwise Noted)**

Parameter	Min.	Typ.	Max.	Unit	Test Conditions
Peak Wavelength	—	560	—	nm	
Full Scale ADC Count Value	—	—	262143	counts	18 bits, 100 ms, G = 1x
Dark ALS ADC Count Value	0	—	3	counts	G = 18x, 50 ms
ALS ADC Count Value	4000	5000	6000	counts	18 bits, G = 6x, 100 ms, $\lambda = 530$ nm, $E_e = 34 \mu W/cm^2$
ALS ADC Integration Time	3.125	—	400	ms	
Gain Scaling, Relative to 1x Gain Setting	—	3	—		AGAIN = 3x
	—	6	—		AGAIN = 6x
	—	9	—		AGAIN = 9x
	—	18	—		AGAIN = 18x

**Table 7 IR LED Characteristics,  $V_{DD} = 2.8V$ ,  $T_A = 25^\circ C$** 

Parameter	Symbol	Min.	Typ.	Max.	Unit	Test Conditions
Peak Wavelength	$\lambda_p$	—	850	—	nm	$I_F = 20$ mA
Spectrum Width, Half Power	$\Delta\lambda$	—	40	—	nm	$I_F = 20$ mA
Optical Rise Time	$T_R$	—	20	—	ns	$I_{FP} = 100$ mA
Optical Fall Time	$T_F$	—	20	—	ns	$I_{FP} = 100$ mA

**Table 8 PS Characteristics,  $V_{DD} = 2.8V$ ,  $T_A = 25^\circ C$  (unless Otherwise Noted)**

Parameter	Min.	Typ.	Max.	Unit	Test Conditions
Supply Current (w/o LED Current)	—	115	—	$\mu A$	
PS Integration Time	0.01	—	4.25	ms	
Full Scale ADC Count Value	—	—	2047	counts	
PS Resolution	8	—	11	bits	
IR LED Pulse Count	1	—	255	pulses	
Proximity LED Drive	2.5	—	125	mA	$I_{SINK}$ Sink current at 600 mV, LDR pin.
Frequency of PS Led Pulses (Programmable)	60	60	100	kHz	
Duty Ratio of PS Led Pulses	50%	—	—		
PS ADC Count Value (No Object)	0	—	20	counts	Dedicated duo power supply, $V_{DD} = 2.8V$ and $V_{LED} = 3V$ . LED driving 32 pulses, 100 mA, 60 kHz, 8-bit. Open view (no glass) and no reflective object above the module.
PS ADC Count Value (70-mm Distance Object)	44	52	60	counts	Dedicated duo power supply, $V_{DD} = 2.8V$ and $V_{LED} = 3V$ . Reflecting object – 73 mm x 83 mm Kodak 90% grey card, 70-mm distance, LED driving 32 pulses, 100 mA, 60 KHz, 8-bit. Open view (no glass) above the module.

**Table 9 Characteristics of the SDA and SCL Bus Lines,  $V_{DD} = 2.8V$ ,  $T_A = 25^\circ C$  (unless Otherwise Noted)**

Parameter	Symbol	Min.	Typ.	Max.	Unit
SCL Clock Frequency	$f_{SCL}$	0	—	400	kHz
Hold Time (repeated) START Condition. (After this period, the first clock pulse is generated.)	$t_{HD;STA}$	0.6	—	—	$\mu s$
LOW Period of the SCL Clock	$t_{LOW}$	1.3	—	—	$\mu s$
HIGH Period of the SCL Clock	$t_{HIGH}$	0.6	—	—	$\mu s$
Set-up Time for a Repeated START Condition	$t_{SU;STA}$	0.6	—	—	$\mu s$
Data Hold Time	$t_{HD;DAT}$	0	—	0.9	$\mu s$
Data Set-up Time	$t_{SU;DAT}$	100	—	—	ns
Clock/Data Fall Time	$t_f$	0	—	300	ns
Clock/Data Rise Time	$t_r$	0	—	300	ns
Set-up Time for STOP Condition	$t_{SU;STO}$	0.6	—	—	$\mu s$
Bus Free Time between a STOP and START Condition	$t_{BUF}$	1.3	—	—	$\mu s$

**Figure 2 Spectral Response**

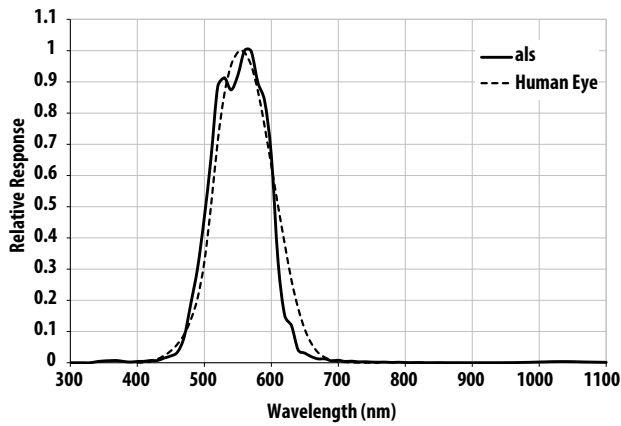

**Figure 3 ALS Sensor LUX vs Meter LUX using White Light**

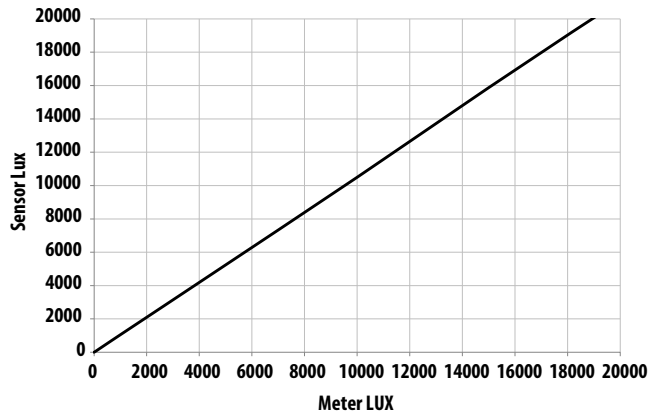

**Figure 4 ALS Sensor LUX vs Meter LUX using Low LUX White Light**

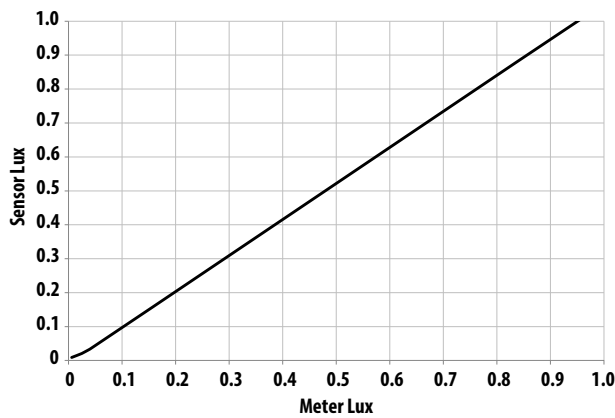

**Figure 5 ALS Sensor LUX vs Meter LUX using Incandescent Light**

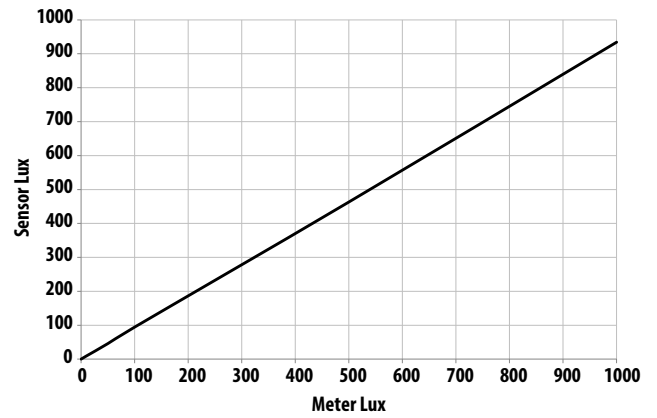

**Figure 6 Normalized IDD vs VDD**

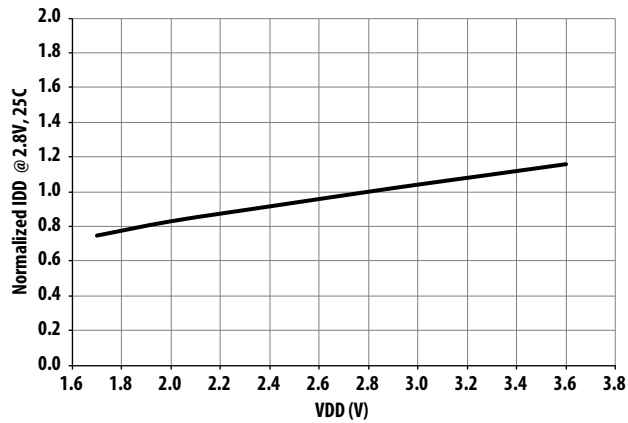

**Figure 7 Normalized IDD vs Temperature**

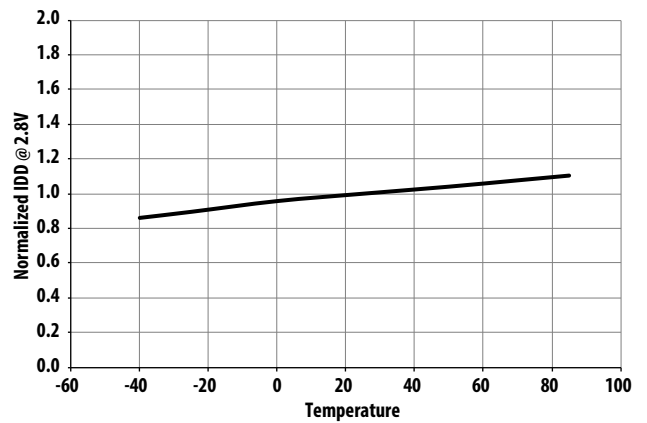

Figure 8 Normalized PD Responsivity vs. Angular Displacement

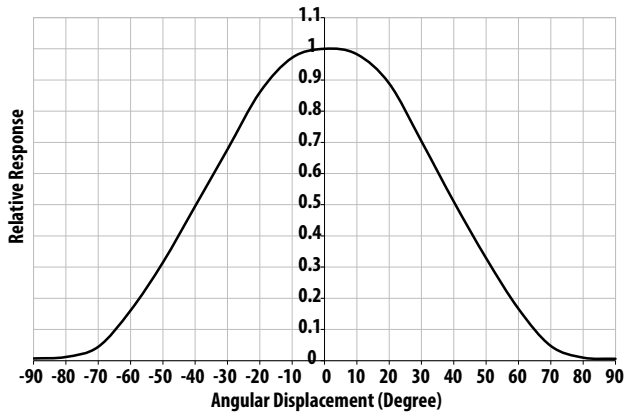
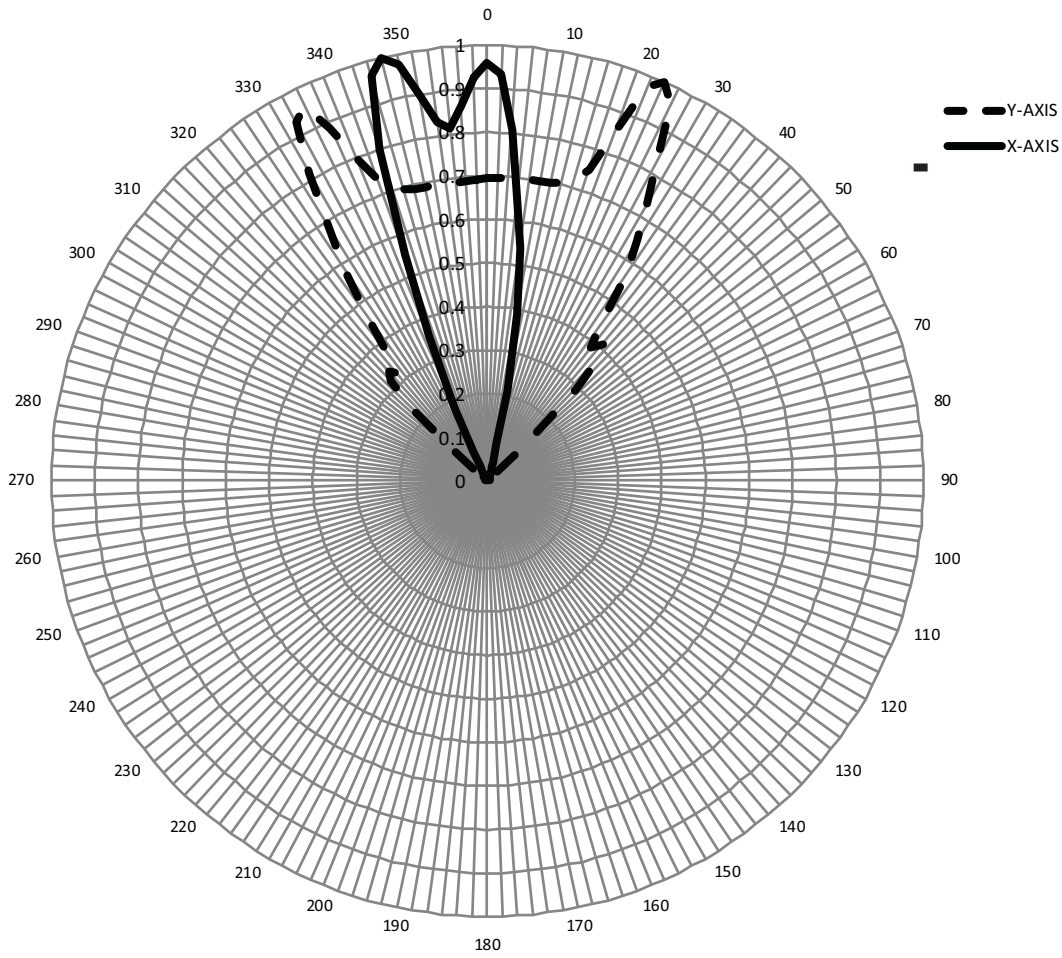

Figure 9 Normalized LED Angular Emitting Profile



## Start Up after Power-On or Software Reset

The main state machine is set to Start state during power-on or software reset. As soon as the reset is released, the internal oscillator is started and the programmed I<sup>2</sup>C address and the trim values are read from the internal nonvolatile memory (NVM) trimming data block. The device enters Standby mode as soon as the Idle State is reached.

**NOTE** As long as the I<sup>2</sup>C address has not yet been reached, the device will respond with NACK to any I<sup>2</sup>C command and ignore any request to avoid responding to a wrong I<sup>2</sup>C address.

## Standby Mode

Standby mode is the default mode after power-up. In this state, the oscillator, all internal support blocks, and the ADCs are switched off, but I<sup>2</sup>C communication is fully supported.

## Ambient Light and Proximity Sensor Operation

ALS measurements can be activated by setting the ALS\_EN bit to 1 in the MAIN\_CTRL register.

PS measurement can be activated by setting the PS\_EN bit to 1 in the MAIN\_CTRL register.

As soon as the PS sensors, the ALS sensors, or both become activated through an I<sup>2</sup>C command, the internal support blocks are powered on. When the voltages and currents are settled (typically after 5 ms), the state machine checks for trigger events from a measurement scheduler to start the ALS or PS conversions according to the selected measurement repeat rates.

When PS\_EN or ALS\_EN is changed back to 0, a conversation running on the respective channel will be completed, and the relevant ADCs and support blocks will move to Standby mode.

**Figure 10 Ambient Light and Proximity Sensor Operation**

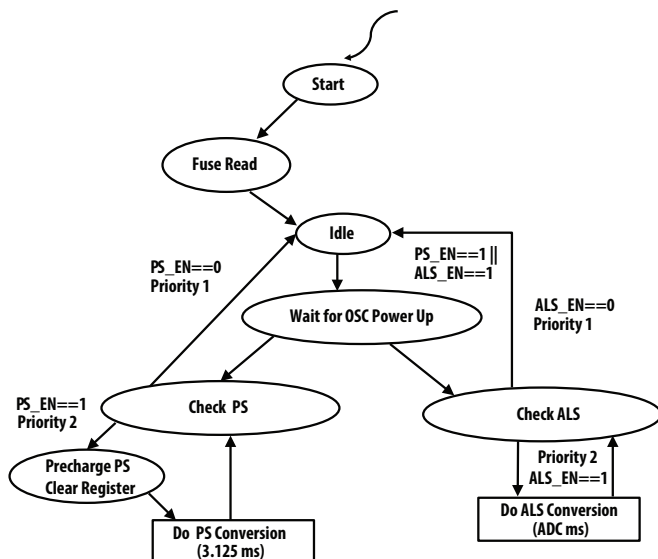

## Ambient Light Sensor Interrupt

The ALS interrupt is enabled by ALS\_INT\_EN = 1 and can function as either threshold triggered (ALS\_VAR\_MODE = 0) or variance triggered (ALS\_VAR\_MODE = 1).

The ALS threshold interrupt is enabled with ALS\_INT\_EN = 1 and ALS\_VAR\_MODE = 0. It is set when the ALS data is above the upper or below the lower ALS threshold for a specified number of consecutive measurements (1 + ALS\_PERSIST).



The ALS variance interrupt is enabled with  $ALS\_INT\_EN = 1$  and  $ALS\_VAR\_MODE = 1$ . It is set when the absolute value of the difference between previous and current ALS data is above the decoded ALS variance threshold for a specified number of consecutive measurements ( $1 + ALS\_PERSIST$ ).

### Proximity Sensor Interrupt

The PS interrupt is enabled by  $PS\_INT\_EN = 1$ . It triggers when the PS conversion result is above the upper or below the lower PS threshold for a specified number of consecutive measurements ( $1 + PS\_PERSIST$ ).

The  $PS\_LOGIC$  signal is set to 0 if the PS data is below the lower threshold, and it is set to 1 if the PS data is above the upper PS threshold.

Two options indicate a PS interrupt signal on the INT pad; as a continuous logic signal ( $PS\_LOGIC\_MODE = 1$ ) or as an edge-triggered interrupt signal ( $PS\_LOGIC\_MODE = 0$ ), which is cleared with the next read-out of the MAIN\_STATUS register.

The  $PS\_INT\_SOURCE$  and the  $PS\_LOGIC$  signals also are stored in the MAIN STATUS register as the flag bits PS Interrupt Status and the PS Logic signal status, respectively. The PS interrupt status flag is cleared by reading the MAIN\_STATUS register. The PS logic signal status flag always retains the value of the  $PS\_LOGIC$  signal.

**Figure 11 Proximity Sensor Interrupt**

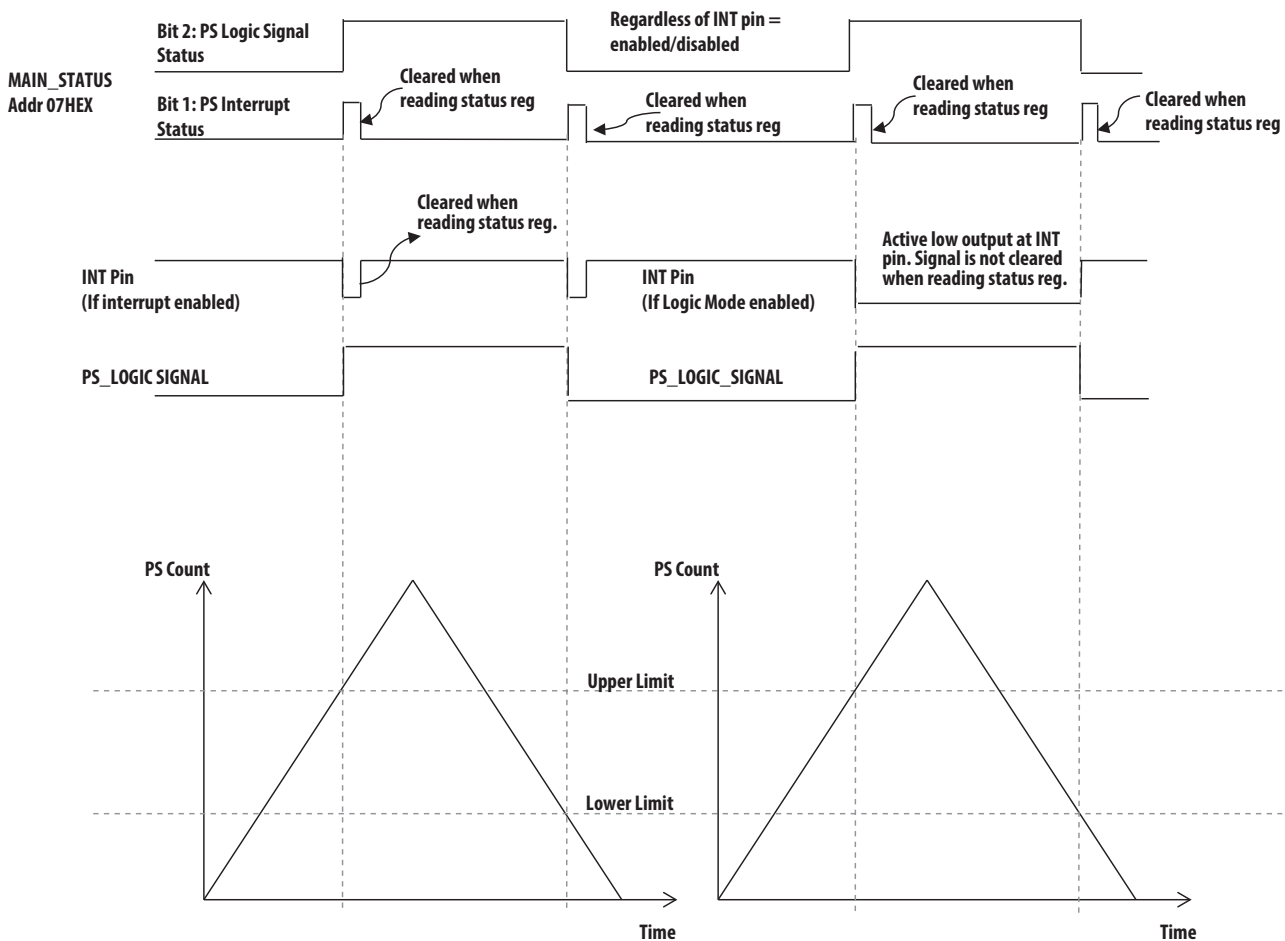

## Interrupt

The APDS-9922-001 generates independent ALS and PS interrupt signals that can be multiplexed and output to the INT pad. The interrupt conditions are always evaluated after completion of a new conversion on the ALS and PS channels. The PS logic output mode has priority over any other interrupt signal. If selected (PS\_LOGIC\_MODE = 1), no ALS interrupt can be signaled at the INT pad. Both ALS and PS, as well as PS\_LOGIC\_MODE are active low at the INT pin.

The PS\_INT\_SOURCE and the PS\_LOGIC signals are stored in the MAIN\_STATUS register as the flag bits PS Interrupt Status and PS Logic Signal Status, respectively. The PS Interrupt Status flag is cleared by reading the MAIN\_STATUS register. The PS Logic Signal Status Flag always retains the value of the PS\_LOGIC signal.

## I<sup>2</sup>C Protocol

Interface and control of the APDS-9922-001 is accomplished through an I<sup>2</sup>C serial compatible interface (Standard or Fast mode) to a set of registers that provide access to device control functions and output data. The device supports a single slave address of 0x53 hexadecimal using a 7-bit addressing protocol. (Contact the factory for other addressing options.)

## I<sup>2</sup>C Register Read

The registers can be read individually or in Block Read mode. When two or more bytes are read in Block Read mode, reserved register addresses are skipped, and the next valid address is referenced. If the last valid address has been reached, but the master continues with the block read, the address counter in the device does not roll over, and the device returns 00HEX for every subsequent byte read.

The block read operation is the only way to ensure correct data read out of multi-byte registers and to avoid splitting of results with HIGH and LOW bytes originating from different conversions. During block read access on ALS result registers, the result update is blocked.

If a read access is started on an address belonging to a nonreadable register, the APDS-9922-001 will return NACK until the I<sup>2</sup>C operation is ended.

Read operations must follow the timing diagram shown in [Figure 14](#).

**Figure 12 I<sup>2</sup>C Register Read**

### Register Read (I<sup>2</sup>C™ Read)

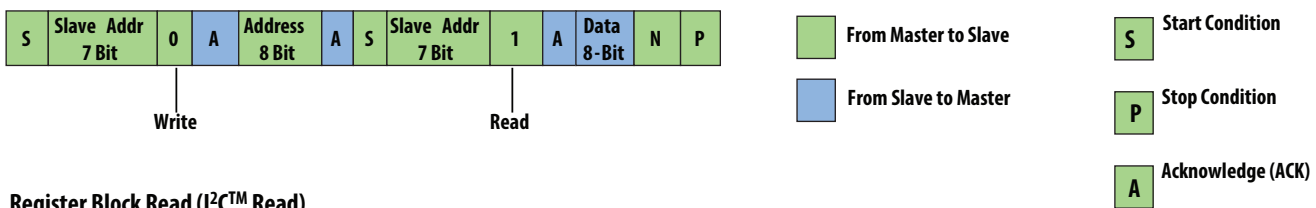

### Register Block Read (I<sup>2</sup>C™ Read)

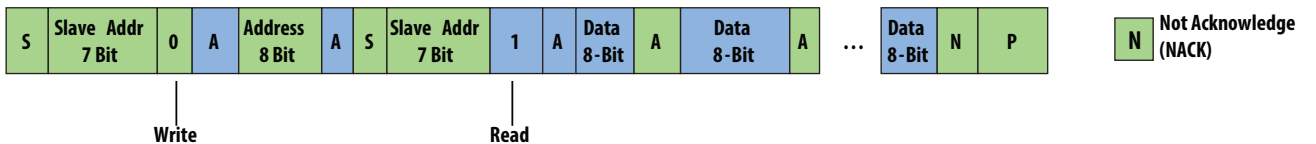

## I<sup>2</sup>C Register Write

The APDS-9922-001 registers can be written to individually or in Block Write mode. When two or more bytes are written in Block Write mode, reserved registers and read-only registers are skipped. The transmitted data is automatically applied to the next writable register. If a register includes read (R) and read/write (RW) bits, the register is not skipped. Data written to read-only bits are ignored.

If the last valid address of the APDS-9922-001 address range is reached but the master attempts to continue the block write operation, the address counter of the APDS-9922-001 does not roll over. The APDS-9922-001 returns NACK for every following byte sent by the master until the I<sup>2</sup>C operation is ended.

If a write access is started on an address belonging to a non-writeable register, the APDS-9922-001 returns NACK until the I<sup>2</sup>C operation is ended.

Write operations must follow the timing diagram shown in [Figure 14](#).

**Figure 13 I<sup>2</sup>C Register Write**

### Register Write (I<sup>2</sup>C™ Write)

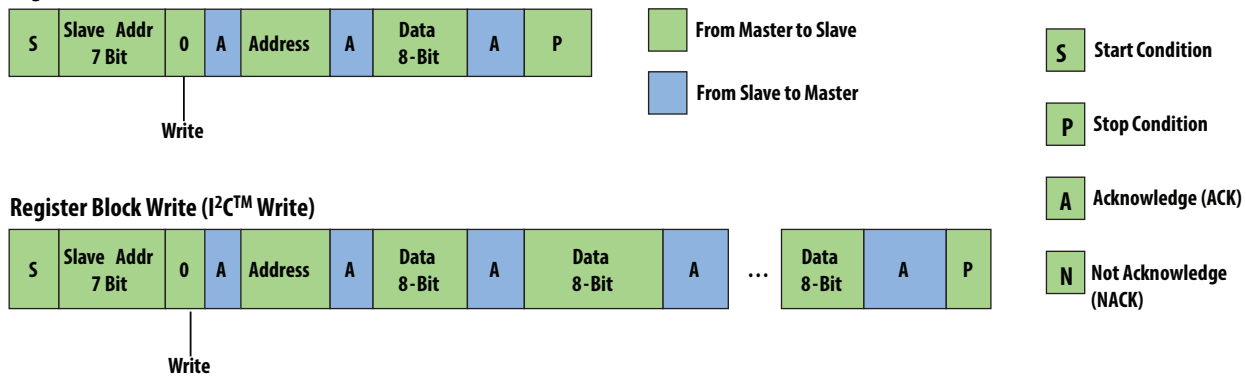

**Figure 14 I<sup>2</sup>C Interface – Bus Timing**

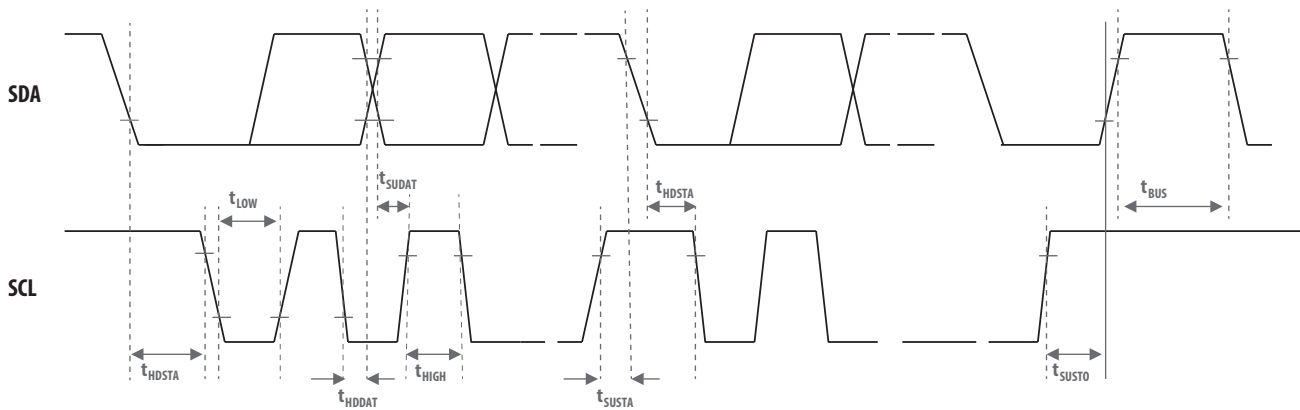

**Table 10 Bus Timing Characteristics**

Parameter	Symbol	Standard Mode	Fast Mode	Unit
Maximum SCL Clock Frequency	$f_{SCL}$	100	400	KHz
Minimum START Condition Hold Time Relative to SCL Edge	$t_{DSTA}$	4	—	$\mu s$
Minimum SCL Clock Low Width	$t_{LOW}$	4.7	—	$\mu s$
Minimum SCL Clock High Width	$t_{HIGH}$	4	—	$\mu s$
Minimum START Condition Setup Time Relative to SCL Edge	$t_{SUSTA}$	4.7	—	$\mu s$
Minimum Data Hold Time on SDA Relative to SCL Edge	$t_{HDDAT}$	0	—	$\mu s$
Minimum Data Setup Time on SDA Relative to SCL Edge	$t_{SUDAT}$	0.1	0.1	$\mu s$
Minimum STOP Condition Setup Time on SCL	$t_{SUSTO}$	4	—	$\mu s$
Minimum Bus Free Time Between Stop Condition and Start Condition	$t_{BUS}$	4.7	—	$\mu s$

## Register Set

The APDS-9922-001 is controlled and monitored by data registers and a command register accessed through the serial interface. These registers provide for a variety of control functions and can be read to determine results of the ADC conversions.

**Table 11 Register Set**

Address	Type	Name	Description	Reset Value
00HEX	RW	MAIN_CTRL	ALS operation mode control, SW reset	00HEX
01HEX	RW	PS_LED	PS LED settings	36HEX
02HEX	RW	PS_PULSES	PS number of LED pulses	08HEX
03HEX	RW	PS_MEAS_RATE	PS measurement rate in active mode	45HEX
04HEX	RW	ALS_MEAS_RATE	ALS measurement rate and resolution in active mode	22HEX
05HEX	RW	ALS_GAIN	ALS analog gain range	01HEX
06HEX	R	PART_ID	Part number ID and revision ID	B3HEX
07HEX	R	MAIN_STATUS	Power-on status, interrupt status, data status	20HEX
08HEX	R	PS_DATA_0	PS measurement data, least significant bits	00HEX
09HEX	R	PS_DATA_1	PS measurement data, most significant bits, and overflow	00HEX
0DHEX	R	ALS_DATA_0	ALS ADC measurement data - LSB	00HEX
0EHEX	R	ALS_DATA_1	ALS ADC measurement data	00HEX
0FHEX	R	ALS_DATA_2	ALS ADC measurement data - MSB	00HEX
19HEX	RW	INT_CFG	Interrupt configuration	10HEX
1AHEX	RW	INT_PERSISTENCE	Interrupt persist setting	00HEX
1BHEX	RW	PS_THRES_UP_0	PS interrupt upper threshold, LSB	FFHEX
1CHEX	RW	PS_THRES_UP_1	PS interrupt upper threshold, MSB	07HEX
1DHEX	RW	PS_THRES_LOW_0	PS interrupt lower threshold, LSB	00HEX
1EHEX	RW	PS_THRES_LOW_1	PS interrupt lower threshold, MSB	00HEX
1FHEX	RW	PS_CAN_0	PS intelligent cancellation level setting, LSB	00HEX
20HEX	RW	PS_CAN_1	PS intelligent cancellation level setting, MSB	00HEX
21HEX	RW	ALS_THRES_UP_0	ALS interrupt upper threshold, LSB	FFHEX
22HEX	RW	ALS_THRES_UP_1	ALS interrupt upper threshold	FFHEX
23HEX	RW	ALS_THRES_UP_2	ALS interrupt upper threshold, MSB	0FHEX
24HEX	RW	ALS_THRES_LOW_0	ALS interrupt lower threshold, LSB	00HEX
25HEX	RW	ALS_THRES_LOW_1	ALS interrupt lower threshold	00HEX
26HEX	RW	ALS_THRES_LOW_2	ALS interrupt lower threshold, MSB	00HEX
27HEX	RW	ALS_THRES_VAR	ALS interrupt variance threshold	00HEX

## MAIN\_CTRL

Default Value: 00HEX

7	6	5	4	3	2	1	0	0X00
0	0	0	SW_Reset	0	0	ALS_EN	PS_EN	

Field	Bit	Description
SW_Reset	4	1 = Reset will be triggered
ALS_EN	1	1 = ALS active 0 = ALS standby
PS_EN	1	1 = PS active 0 = PS standby

Writing to this register stops the ongoing measurements (both ALS and PS) and starts new measurements (depending on the respective enable bits).

## PS\_LED

Default Value: 36HEX

7	6	5	4	3	2	1	0	0X01
0	LED Pulse Modulation Frequency			LED Current Peaking	LED Current			

Field	Bit	Description
LED Pulse Modulation Frequency	6:4	000 = Reserved 001 = Reserved 010 = Reserved 011 = LED pulse frequency = 60 KHz (default) 100 = LED pulse frequency = 70 KHz 101 = LED pulse frequency = 80 KHz 110 = LED pulse frequency = 90 KHz 111 = LED pulse frequency = 100 KHz
LED Current Turn-On Acceleration (Peaking) On/Off	3	1 = LED current peaking on 0 = LED current peaking off (default)
LED current	2:0	000 = LED pulsed current level = 2.5 mA 001 = LED pulsed current level = 5.0 mA 010 = LED pulsed current level = 10 mA 011 = LED pulsed current level = 25 mA 100 = LED pulsed current level = 50 mA 101 = LED pulsed current level = 75 mA 110 = LED pulsed current level = 100 mA (default) 111 = LED pulsed current level = 125 mA

Writing to this register stops the ongoing measurements (both ALS and PS) and starts new measurements (depending on the respective enable bits).

## PS\_PULSES

Default Value: 08HEX

7	6	5	4	3	2	1	0	
PS Number of LED Pulses								0X02

Field	Bit	Description
PS_PULSES	7:0	00000000 = 0 pulses (no light emission) ... .. 00001000 = 8 pulses (default) ... .. 00100000 = 32 pulses

Writing to this register stops the ongoing measurements (both ALS and PS) and starts new measurements (depending on the respective enable bits).

## PS\_MEAS\_RATE

Default Value: 45HEX

7	6	5	4	3	2	1	0	
Reserved			PS Resolution / Bit Width		PS Measurement Rate			0X03

Field	Bit	Description
Reserved	7:5	Reserved. Write as 010.
PS Resolution	4:3	00 = 8 bit (default) 01 = 9 bit 10 = 10 bit 11 = 11 bit
PS Measurement Rate	2:0	000 = Reserved 001 = 6.25 ms 010 = 12.5 ms 011 = 25 ms 100 = 50 ms 101 = 100 ms (default) 110 = 200 ms 111 = 400 ms

Bit 2:0 register controls the timing of the periodic measurements of the PS in Active Mode.

When the measurement repeat rate is programmed to be faster than possible for the programmed ADC measurement time, the repeat rate will be lower than programmed (maximum speed).

Writing to this register stops the ongoing measurements (both ALS and PS) and starts new measurements (depending on the respective enable bits).

## ALS\_MEAS\_RATE

Default Value: 22HEX

7	6	5	4	3	2	1	0	
0	ALS Resolution/Bit Width			0	ALS Measurement Rate			0X04

Field	Bit	Description
ALS Resolution/Bit Width	6:4	000 = 20 bit – 400 ms 001 = 19 bit – 200 ms 010 = 18 bit – 100 ms (default) 011 = 17 bit – 50 ms 100 = 16 bit – 25 ms 101 = 13 bit – 3.125 ms 110 = Reserved 111 = Reserved
ALS Measurement Rate	2:0	000 = 25 ms 001 = 50 ms 010 = 100 ms (default) 011 = 200 ms 100 = 500 ms 101 = 1000 ms 110 = 2000 ms 111 = 2000 ms

Bit 2:0 register controls the timing of the periodic measurements of the ALS in Active Mode.

When the measurement repeat rate is programmed to be faster than possible for the specified ADC measurement time, the repeat rate will be lower than programmed (maximum speed).

Writing to this register stops the ongoing measurement and starts new measurements (depending on the respective bits).

## ALS\_GAIN

Default Value: 01HEX

7	6	5	4	3	2	1	0	
0	0	0	0	0	ALS Gain Range			0X05

Field	Bit	Description
ALS Gain Range	2:0	000 = Gain 1 001 = Gain 3 010 = Gain 6 011 = Gain 9 100 = Gain 18

Writing to this register stops the ongoing measurement and starts new measurements (depending on the respective bits).



## PART\_ID

Default Value: B3HEX

7	6	5	4	3	2	1	0	0X06
Part ID				Revision ID				

Field	Bit	Description
Part Number ID	7:4	Part number ID.
Revision ID	3:0	Revision ID of the component. The value increases by one each time a new silicon revision is manufactured.

## MAIN\_STATUS

Default Value: 20HEX

7	6	5	4	3	2	1	0	0X07
0	0	Power On Status	ALS Interrupt Status	ALS Data Status	PS Logic Signal Status	PS Interrupt Status	PS Data Status	

Field	Bit	Description
Power On status	5	1 = Part went through a power-up event, either because the part was turned on or because there was power supply voltage disturbance. (default at first register read). All interrupt threshold settings in the registers have been reset to power-on default states and should be examined if necessary. The flag is cleared after the register is read.
ALS Interrupt status	4	0 = Interrupt condition not fulfilled (default). 1 = Interrupt condition fulfilled (cleared after read).
ALS Data status	3	0 = Old data, already read (default). 1 = New data, not yet read (cleared after read).
PS Logic Signal Status	2	0 = Object is far (default). 1 = Object is close.
PS Interrupt Status	1	0 = Interrupt condition not fulfilled (default). 1 = Interrupt condition fulfilled (cleared after read).
PS Data Status	0	0 = Old data, already read (default). 1 = New data, not yet read (cleared after read).

## PS\_DATA

Default Value: 00HEX, 00HEX

7	6	5	4	3	2	1	0	
PS_DATA_0								0X08
0	0	0	0	Overflow	PS_DATA_1			0x09

If an I<sup>2</sup>C read operation is active and points to an address in the range 07HEX to 18HEX, both registers PS\_DATA\_0 and PS\_DATA\_1 are locked until the I<sup>2</sup>C read operation is completed or the specified address range is left.

This guarantees that the data in the registers comes from the same measurement even if an additional measurement cycle ends during the read operation. New measurement data is stored into temporary registers and the actual PS\_DATA registers are updated as soon as there is no on-going I<sup>2</sup>C read operation to the address range 07HEX to 18HEX.

The PS conversion result is always written LSB-aligned into the PS\_DATA registers, regardless of the conversion resolution selected in the PS\_MEAS\_RATE register. PS\_DATA\_1 is filled with 0 for resolutions lower than 11 bits.

If the PS data is outside of the measurable range, the Overflow flag (PS\_DATA\_1, Bit [3]) is set in any resolution mode.

PS\_DATA is automatically corrected by the value of the PS cancellation register (PS\_CAN).

$$PS\_DATA = PS\_meas - PS\_CAN$$

PS\_meas is the internal raw value obtained from the PS ADC. If PS\_meas is already full-scale, the value of PS\_DATA is set to its maximum value without subtracting the PS cancellation value.

Reg 08HEX	Bit[7:0]	PS measurement least significant data byte, bit 0 is the LSB of the data word
Reg 09HEX	Bit[2:0]	PS measurement most significant data byte, bit 2 is MSB in 11-bit mode
	Bit[3]	0: valid PS data (default); 1: overflow of PS data

## ALS\_DATA

Default Value: 00HEX, 00HEX, 00HEX

7	6	5	4	3	2	1	0	
ALS_DATA_0 [7:0]								0X0D
ALS_DATA_1 [15:8]								0X0E
0	0	0	0	ALS_DATA_2 [19:16]				0X0F

ALS channel digital output data (unsigned integer, 13 to 20 bit, LSB aligned).

The ALS channel output is already compensated internally: ALS\_DATA = (ALSint – COMP).

When an I<sup>2</sup>C read operation is active and points to an address in the range 07HEX to 18HEX, all registers in this range are locked until the I<sup>2</sup>C read operation is completed or this address range is left.

This guarantees that the data in the registers comes from the same measurement even if an additional measurement cycle ends during the read operation. New measurement data is stored into temporary registers and the actual ALS\_DATA registers are updated as soon as there is no ongoing I<sup>2</sup>C read operation to the address range 07HEX to 18HEX.

Reg 0DHEX	Bit[7:0]	ALS diode data least significant data byte
Reg 0EHEX	Bit[7:0]	ALS diode data intervening data byte
Reg 0FHEX	Bit[3:0]	ALS diode data most significant data byte

## INT\_CFG

Default Value: 10HEX

7	6	[5:4]	3	2	1	0	
0	0	ALS_Interrupt Source	ALS Variation Interrupt Mode	ALS Interrupt Enable	PS Logic Output	PS Interrupt Enable	0X19
0	0	ALS_INT_SEL	ALS_VAR_MODE	ALS_INT_EN	PS_LOGIC_MODE	PS_INT_EN	

Field	Bit	Description
ALS_INT_SEL	5:4	00 = Clear channel. 01 = ALS channel (default).
ALS_VAR_MODE	3	0 = ALS threshold interrupt mode (default). 1 = ALS variation interrupt mode.
ALS_INT_EN	2	0 = ALS Interrupt disabled (default). 1 = ALS Interrupt enabled.
PS_LOGIC_MODE	1	0 = Normal interrupt function: after interrupt event, INT pad maintains active level until MAIN_STATUS register is read (default). 1 = PS Logic Output Mode: INT pad is updated after every measurement and maintains output state between measurements.
PS_INT_EN	0	0 = PS Interrupt disabled (default). 1 = PS Interrupt enabled.

## INT\_PERSISTENCE

Default Value: 00HEX

7	6	5	4	3	2	1	0	
ALS_PERSIST				PS_PERSIST				0X1A

This register sets the number of similar consecutive LS interrupt events that must occur before the interrupt is asserted.

Field	Bit	Description
ALS_PERSIST	7:4	0000 = Every ALS value out of threshold range (default) asserts an interrupt. 0001 = 2 consecutive ALS values out of threshold range assert an interrupt. ... 1111 = 16 consecutive ALS values out of threshold range assert an interrupt.
PS_PERSIST	3:0	0000 = Every PS value out of threshold range (default) asserts an interrupt. 0001 = 2 consecutive PS values out of threshold range assert an interrupt. ... 1111 = 16 consecutive PS values out of threshold range assert an interrupt.

## PS\_THRES\_UP

Default Value: FFHEX, 07HEX

7	6	5	4	3	2	1	0	
PS_THRES_UP_0								0X1B
0	0	0	0	0	PS_THRES_UP_1			0X1C

PS\_THRES\_UP\_x sets the upper threshold value for the PS interrupt. The Interrupt Controller compares the value in PS\_THRES\_UP\_x against measured data in the PS\_DATA\_x registers. It generates an interrupt event if PS\_DATA\_x exceeds the upper threshold level.

The data format for PS\_THRES\_UP\_x must match that of the PS\_DATA\_x registers.

For resolutions below 11 bits, the threshold is evaluated LSB-aligned.

Reg 1BHEX	Bit[7:0]	PS upper interrupt threshold value, LSB
Reg 1CHEX	Bit[2:0]	PS upper interrupt threshold value, intervening byte

## PS\_THRES\_LOW

Default Value: 00HEX, 00HEX

7	6	5	4	3	2	1	0	
PS_THRES_LOW_0								0x1D
0	0	0	0	0	PS_THRES_LOW_1			0x1E

PS\_THRES\_LOW\_x sets the lower threshold value for the PS interrupt. The Interrupt Controller compares the value in PS\_THRES\_LOW\_x against measured data in the PS\_DATA\_x registers. It generates an interrupt event if PS\_DATA\_x is lower than the lower threshold level.

For resolutions below 11 bit, the threshold is evaluated LSB-aligned.

Reg 1DHEX	Bit[7:0]	PS lower interrupt threshold value, LSB
Reg 1EHEX	Bit[2:0]	PS lower interrupt threshold value, intervening byte

## PS\_INTELLIGENT CANCELLATION LEVEL

Default Value: 00HEX, 00HEX

7	6	5	4	3	2	1	0	
PS_CAN_0								0X1F
0	0	0	0	0	PS_CAN_1			0x20

The PS cancellation level is expected to be written by the MCU during system start up. The value is subtracted from the measured PS data before the data is transferred to the PS\_Data registers and evaluated by the Interrupt Controller.

Reg 1FHEX	Bit[7:0]	PS cancellation level, LSB
Reg 20HEX	Bit[2:0]	PS cancellation level, MSB

## ALS\_THRES\_UP

Default Value: FFHEX, FFHEX, 0FHEX

7	6	5	4	3	2	1	0	
ALS_THRES_UP_0								0x21
ALS_THRES_UP_1								0x22
0	0	0	0	ALS_THRES_UP_2				0x23

ALS\_THRES\_UP\_x sets the upper threshold value for the ALS interrupt. The Interrupt Controller compares the value in ALS\_THRES\_UP\_x against measured data in the ALS\_DATA\_x registers of the selected ALS interrupt channel. It generates an interrupt event if ALS\_DATA\_x exceeds the threshold level.

The data format for ALS\_THRES\_UP\_x must match that of the ALS\_DATA\_x registers.

Reg 21HEX	Bit[7:0]	ALS upper interrupt threshold value, LSB
Reg 22HEX	Bit[7:0]	ALS upper interrupt threshold value, intervening byte
Reg 23HEX	Bit[3:0]	ALS upper interrupt threshold value, MSB

## ALS\_THRES\_LOW

Default Value: 00HEX, 00HEX, 00HEX

7	6	5	4	3	2	1	0	
ALS_THRES_LOW_0								0x24
ALS_THRES_LOW_1								0x25
0	0	0	0	ALS_THRES_LOW_2				0x26

ALS\_THRES\_LOW\_x sets the lower threshold value for the ALS interrupt. The Interrupt Controller compares the value in ALS\_THRES\_LOW\_x against measured data in the ALS\_DATA\_x registers of the selected LS interrupt channel. It generates an interrupt event if the ALS\_DATA\_x is below the threshold level.

The data format for ALS\_THRES\_LOW\_x must match that of the ALS\_DATA\_x registers.

Reg 24HEX	Bit[7:0]	ALS lower interrupt threshold value, LSB
Reg 25HEX	Bit[7:0]	ALS lower interrupt threshold value, intervening byte
Reg 26HEX	Bit[3:0]	ALS lower interrupt threshold value, MSB

## ALS\_THRES\_VAR

Default Value: 00HEX

7	6	5	4	3	2	1	0
0	0	0	0	0	ALS_THRES_VAR		0X27

Field	Bit	Description
ALS_THRES_VAR	2:0	000 = ALS result varies by 8 counts compared to previous result 001 = ALS result varies by 16 counts compared to previous result 010 = ALS result varies by 32 counts compared to previous result 011 = ALS result varies by 64 counts compared to previous result ... 111 = ALS result varies by 1024 counts compared to previous result

## Application Information: Hardware

In a proximity sensing system, the included IR LED can be pulsed with more than 100 mA of rapidly switching current, therefore, a few design considerations must be kept in mind to get the best performance. The key goal is to reduce the power supply noise coupled back into the device during the LED pulses. Averaging of multiple proximity samples is recommended to reduce the proximity noise.

The first recommendation is to use two power supplies; one for the device  $V_{DD}$  and the other for the IR LED. In many systems, there is a quiet analog supply and a noisy digital supply. By connecting the quiet supply to the  $V_{DD}$  pin and the noisy supply to the LEDA pin, the key goal can be met. Place a 1- $\mu\text{F}$  low-ESR decoupling capacitor as close as possible to the  $V_{DD}$  pin and 4.7  $\mu\text{F}$  at the LEDA pin, and at least 10  $\mu\text{F}$  of bulk capacitance to supply the 100 mA current surge.

**Figure 15 Proximity Sensing using Separate Power Supplies**

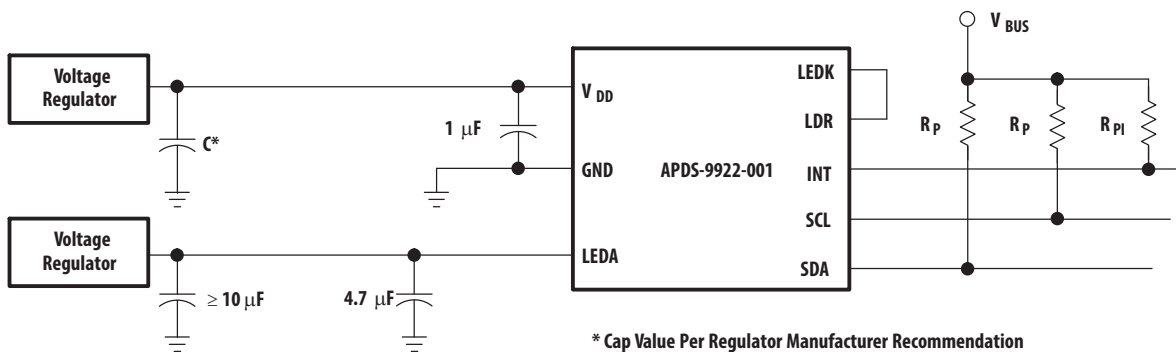

If it is not possible to provide two separate power supplies, the device can be operated from a single supply. A 100 $\Omega$  resistor in series with the  $V_{DD}$  supply line and a 4.7- $\mu\text{F}$  ESR capacitor effectively filter any power supply noise. The previous capacitor placement considerations apply.

**Figure 16 Proximity Sensing using a Single Power Supply**

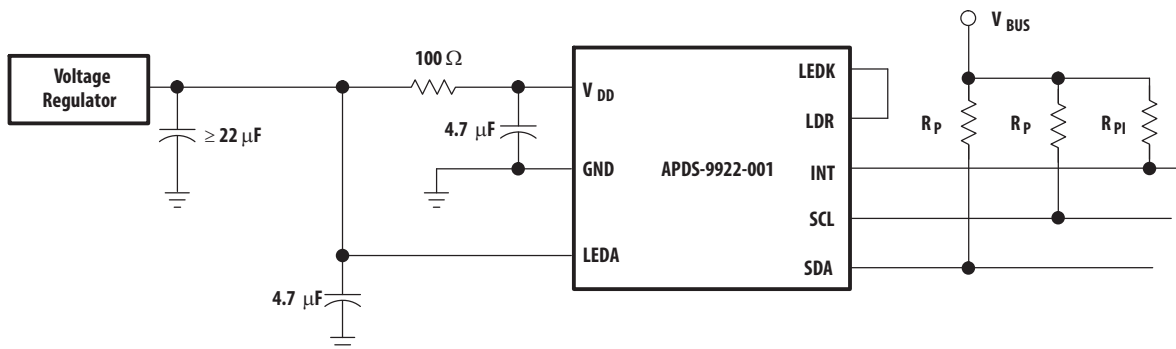

$V_{BUS}$  in the preceding figures refers to the I<sup>2</sup>C bus voltage. The I<sup>2</sup>C signals and the Interrupt are open-drain outputs and require pull-up resistors. The pull-up resistor ( $R_p$ ) value is a function of the I<sup>2</sup>C bus speed, the I<sup>2</sup>C bus voltage, and the capacitive load. A 10-k $\Omega$  pull-up resistor ( $R_{PI}$ ) can be used for the interrupt line.

**Figure 17 Package Outline Dimensions**

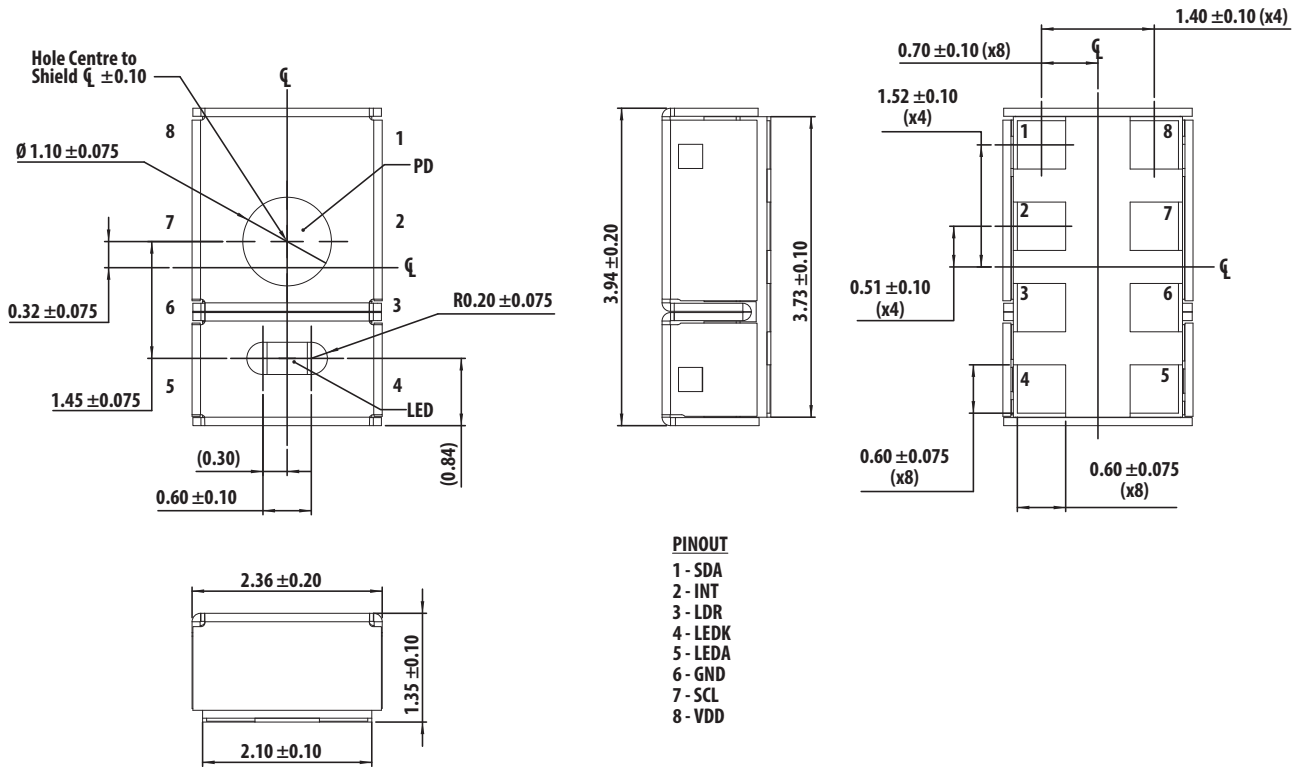

**NOTE** All linear dimensions are in mm.

Suggested PCB pad layout guidelines for the Dual Flat No-Lead surface mount package are as follows.

**Figure 18 PCB Pad Layout**

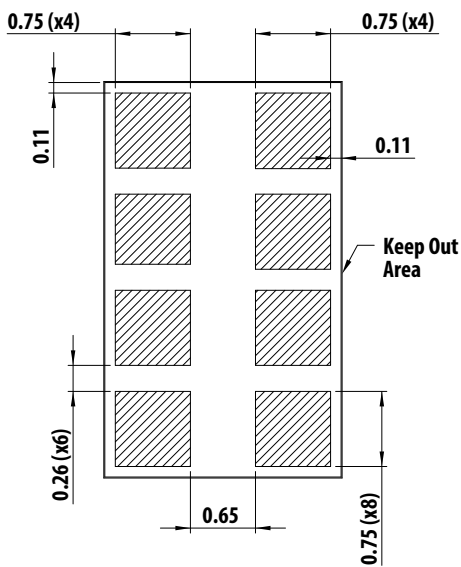

**NOTE** All linear dimensions are in mm.



Figure 19 Tape Dimensions

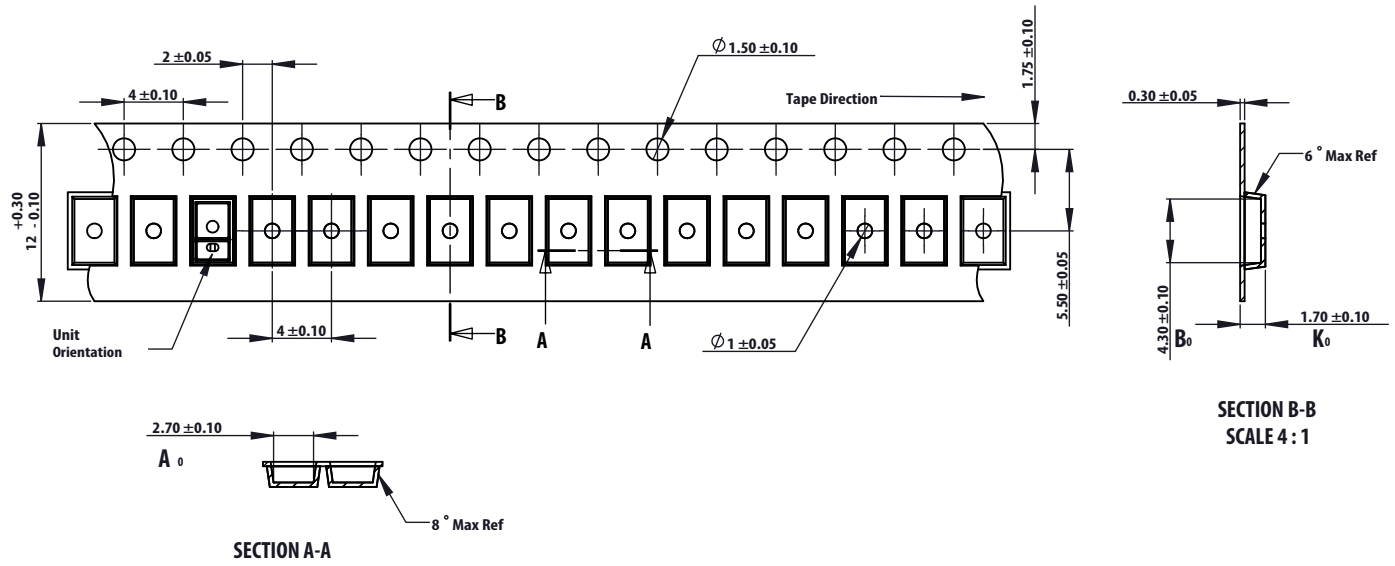
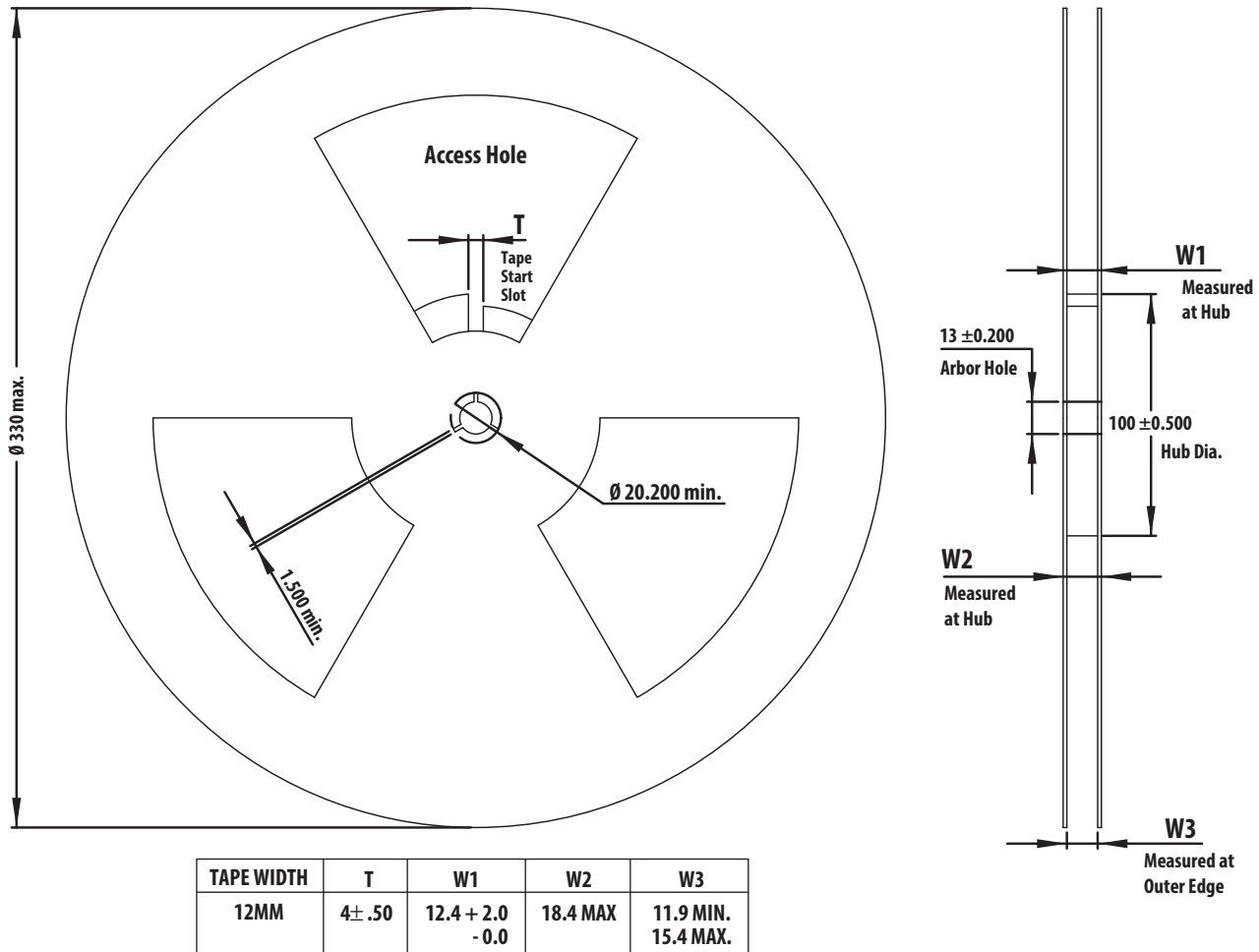

Figure 20 Reel Dimensions



## Moisture Proof Packaging

All APDS-9922-001 options are shipped in moisture proof package. Once opened, moisture absorption begins. This part is compliant to JEDEC MSL 3.

**Figure 21 Moisture Proof Packaging**

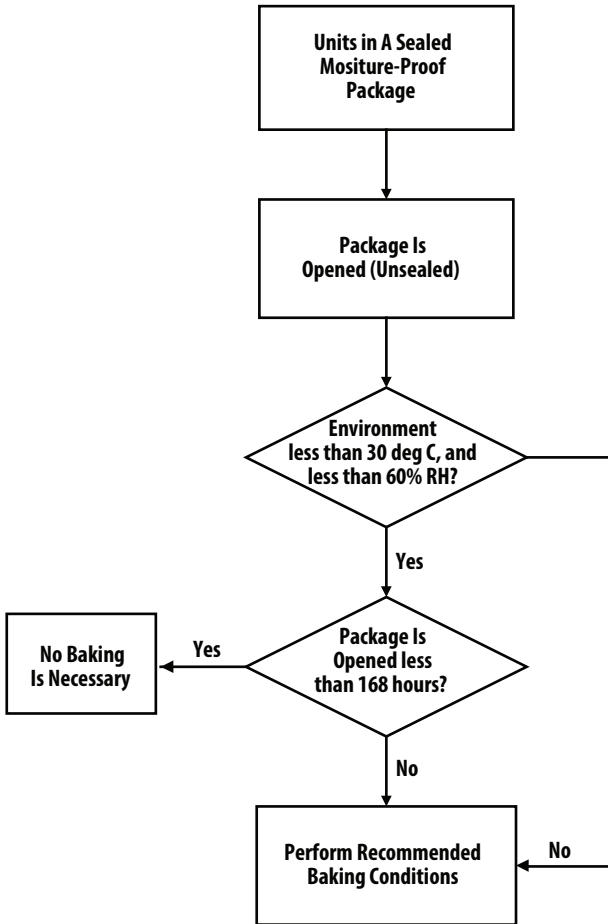

**Table 12 Backing Conditions**

Package	Temperature	Time
In Reel	60°C	48 hours
In Bulk	100°C	4 hours

If the parts are not stored in dry conditions, they must be baked before reflow to prevent damage to the parts.

Baking should only be done once.

**Table 13 Recommended Storage Conditions**

Storage Temperature	10°C to 30°C
Relative Humidity	below 60% RH

**Time from unsealing to soldering:**

After removal from the bag, the parts should be soldered within 168 hours if stored at the recommended storage conditions. If times longer than 168 hours are needed, the parts must be stored in a dry box.

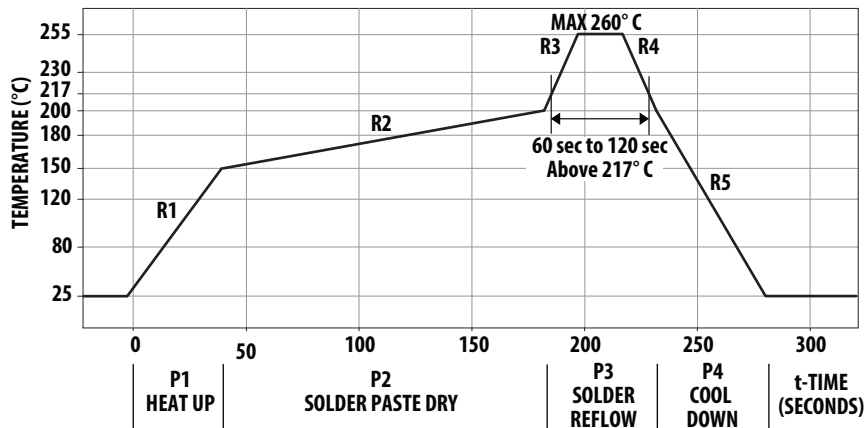
**Figure 22 Recommended Reflow Profile****Table 14 Process Zones**

Process Zone	Symbol	$\Delta T$	Maximum $\Delta T/\Delta$ time or Duration
Heat Up	P1, R1	25°C to 150°C	3°C/s
Solder Paste Dry	P2, R2	150°C to 200°C	100s to 180s
Solder Reflow	P3, R3	200°C to 260°C	3°C/s
	P3, R4	260°C to 200°C	-6°C/s
Cool Down	P4, R5	200°C to 25°C	-6°C/s
Time maintained above liquidus point, 217 °C		> 217°C	60s to 120s
Peak Temperature		260°C	—
Time within 5 °C of actual Peak Temperature		> 255°C	20s to 40s
Time 25 °C to Peak Temperature		25°C to 260°C	8 mins

The reflow profile is a straight-line representation of a nominal temperature profile for a convective reflow solder process. The temperature profile is divided into four process zones, each with different  $\Delta T/\Delta$ time temperature change rates or duration. The  $\Delta T/\Delta$ time rates or duration are detailed in the above table. The temperatures are measured at the component to printed circuit board connections.

In process zone P1, the PC board and component pins are heated to a temperature of 150°C to activate the flux in the solder paste. The temperature ramp up rate, R1, is limited to 3°C per second to allow for even heating of both the PC board and component pins.

Process zone P2 should be of sufficient time duration (100s to 180s) to dry the solder paste. The temperature is raised to a level just below the liquidus point of the solder.

Process zone P3 is the solder reflow zone. In zone P3, the temperature is quickly raised above the liquidus point of solder to 260°C (500°F) for optimum results. The dwell time above the liquidus point of solder should be between 60s and 120s. This is to assure proper coalescing of the solder paste into liquid solder and the formation of good solder connections. Beyond the recommended dwell time the intermetallic growth within the solder connections becomes excessive, resulting in the formation of weak and unreliable connections. The temperature is then rapidly reduced to a point below the solidus temperature of the solder to allow the solder within the connections to freeze solid.

Process zone P4 is the cool down after solder freeze. The cool down rate, R5, from the liquidus point of the solder to 25°C (77°F) should not exceed 6°C per second maximum. This limitation is necessary to allow the PC board and component pins to change dimensions evenly, putting minimal stresses on the component.

It is recommended to perform reflow soldering no more than twice.

---

For product information and a complete list of distributors, please go to our web site: [www.broadcom.com](http://www.broadcom.com).

Broadcom, the pulse logo, Connecting everything, Avago Technologies, Avago, and the A logo are among the trademarks of Broadcom in the United States, certain other countries and/or the EU.

Copyright © 2016–2018 Broadcom. All Rights Reserved.

The term "Broadcom" refers to Broadcom Inc. and/or its subsidiaries. For more information, please visit [www.broadcom.com](http://www.broadcom.com).

Broadcom reserves the right to make changes without further notice to any products or data herein to improve reliability, function, or design.

Information furnished by Broadcom is believed to be accurate and reliable. However, Broadcom does not assume any liability arising out of the application or use of this information, nor the application or use of any product or circuit described herein, neither does it convey any license under its patent rights nor the rights of others.

APDS-9922-001-DS102 – August 29, 2018



# Mouser Electronics

Authorized Distributor

Click to View Pricing, Inventory, Delivery & Lifecycle Information:

[Broadcom Limited:](#)

[APDS-9922-001](#)