

ACPL-M71U and ACPL-M72U

Wide Operating Temperature, High Speed, Low Power
Digital Optocouplers with R²Coupler™ Isolation



Data Sheet

Description

The Avago ACPL-M71U and ACPL-M72U are high temperature, digital CMOS optocouplers in SOIC-5 packages. These optocouplers use the latest CMOS IC technology to achieve outstanding performance and very low power consumption. All devices operate over the -40°C to 125 °C temperature range.

The ACPL-M71U uses a high speed LED, and the ACPL-M72U uses a low current LED for lower power dissipation. The high speed ACPL-M71U featuring a 35 ns maximum propagation delay ($I_F = 10 \text{ mA}$). The ACPL-M72U optocoupler features very low power. With a low 4 mA LED drive current, ACPL-M72U typical propagation delay is 60 ns.

Each digital optocoupler has a CMOS detector IC, an integrated photodiode, a high speed transimpedance amplifier, and a voltage comparator with an output driver.

Avago R²Coupler isolation products provide the reinforced insulation and reliability needed for critical in high temperature industrial applications

Functional Block Diagram

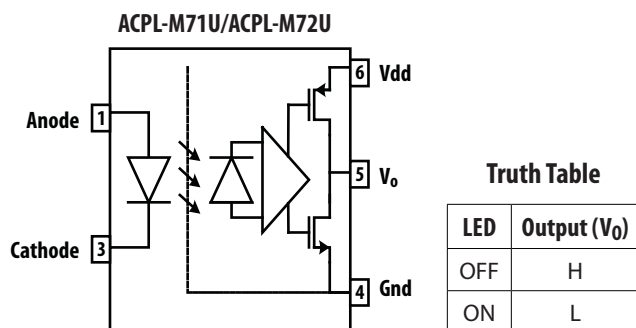

Note: A 0.1 μF bypass capacitor must be connected between pins 4 and 6.

Features

- 5 V CMOS compatible
- Common-Mode Rejection 40kV/ μs @ $V_{CM} = 1000\text{V}$:
- Wide Industrial temperature range: -40°C to 125°C
- Low propagation delay :
 - High Speed ACPL-M71U: 26ns @ $I_F = 10 \text{ mA}$ (Typical)
 - Low Power ACPL-M72U: 60ns @ $I_F = 4 \text{ mA}$ (Typical)
- Worldwide safety approval:
 - UL 1577 recognized, 3750 Vrms / 1 min
 - CSA approved
 - IEC/EN/DIN EN 60747-5-5

Applications

- Industrial CANBus communications interface
- Industrial isolated high speed gate drivers for IGBTs and Power MOSFETs
- High temperature digital signal isolation
- Microcontroller interface
- Digital isolation for A/D and D/A conversion

CAUTION: It is advised that normal static precautions be taken in handling and assembly of this component to prevent damage and/or degradation which may be induced by ESD.

Ordering Information

Part Number	Option		Surface Mount	Tape & Reel	Quantity
	(RoHS) Compliant	Package			
ACPL-M71U	-000E	SO-5	X		100 per tube
	-500E		X	X	1500 per reel
ACPL-M72U	-000E	SO-5	X		100 per tube
	-500E		X	X	1500 per reel

To order, choose a part number from the part number column and combine with the desired option from the option column to form an order entry.

For example, the part number ACPL-M71U-500E describes a device with a surface mount SOIC-5 package; delivered in Tape and Reel with 1500 parts per reel; and full RoHS compliance.

Option datasheets are available. Contact your Avago sales representative or authorized distributor for information.

Package Dimensions

ACPL-M71U / ACPL-M72U (JEDEC MO-155 Package)

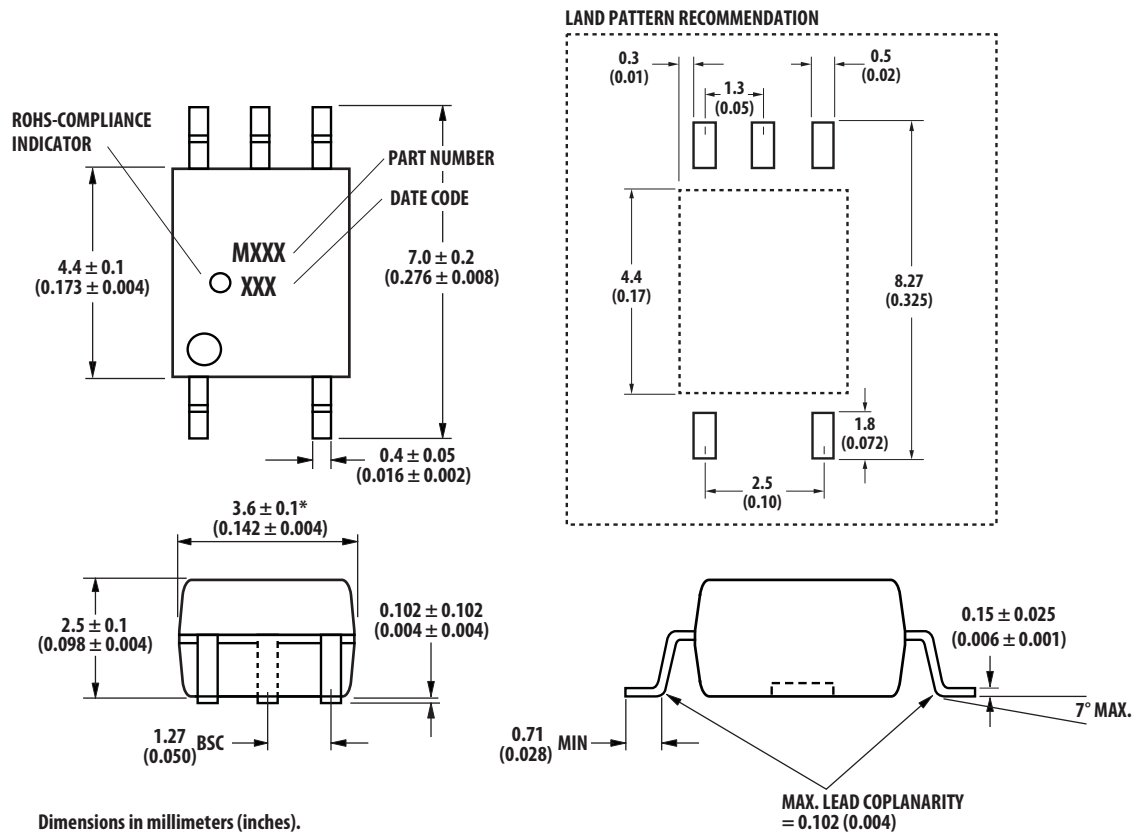

Recommended Pb-Free IR Profile

Recommended reflow condition as per JEDEC Standard, J-STD-020 (latest revision).

Note: Non-halide flux should be used.

Regulatory Information

The ACPL-M71U and ACPL-M72U are approved by the following organizations:

UL

Approved under UL 1577, component recognition program up to $V_{ISO} = 3750 V_{RMS}$ expected prior to product release.

CSA

Approved under CSA Component Acceptance Notice #5.

IEC/EN/DIN EN 60747-5-5

Insulation and Safety Related Specifications

Parameter	Symbol	Value	Units	Conditions
Minimum External Air Gap (Clearance)	L(I01)	>5	mm	Measured from input terminals to output terminals, shortest distance through air.
Minimum External Tracking (Creepage)	L(I02)	>5	mm	Measured from input terminals to output terminals, shortest distance path along body.
Minimum Internal Plastic Gap (Internal Clearance)		0.08	mm	Insulation thickness between emitter and detector; also known as distance through insulation.
Tracking Resistance (Comparative Tracking Index)	CTI	>175	Volts	DIN IEC 112/VDE 0303 Part 1
Isolation Group		IIIa		Material Group (DIN VDE 0109)

IEC/EN/DIN EN 60747-5-5 Insulation Related Characteristics

Description	Symbol	ACPL-M71U/ ACPL-M72U	Units
Maximum Working Insulation Voltage	V_{IORM}	567	V_{PEAK}
Input to Output Test Voltage, Method b [†] $V_{IORM} \times 1.875 = V_{PR}$, 100% Production Test with $t_m = 1$ sec, Partial Discharge < 5 pC	V_{PR}	1063	V_{PEAK}
Input to Output Test Voltage, Method a [†] $V_{IORM} \times 1.6 = V_{PR}$, Type and Sample Test, $t_m = 10$ sec, Partial Discharge < 5 pC	V_{PR}	907	V_{PEAK}
Highest Allowable Overvoltage [†] (Transient Overvoltage, $t_{ini} = 60$ sec)	V_{IOTM}	6000	V_{PEAK}
Safety Limiting Values (Maximum values allowed in the event of a failure, also see Thermal Derating curve, Figure 11.)			
Case Temperature	T_s	175	°C
Input Current	$I_{s, INPUT}$	150	mA
Output Power	$P_{s, OUTPUT}$	600	mW
Insulation Resistance at T_s , $V_{IO} = 500$ V	R_{IO}	$\geq 10^9$	Ω

Absolute Maximum Ratings

Parameter	Symbol	Min.	Max.	Units	Condition
Storage Temperature	T_S	-55	+150	°C	
Ambient Operating Temperature ^[1]	T_A	-40	+125	°C	
Supply Voltages	V_{DD}	0	6.5	Volts	
Output Voltage	V_O	-0.5	$V_{DD} + 0.5$	Volts	
Average Forward Input Current	I_F	-	20.0	mA	
Peak Transient Input Current (I_F at 1 μ s pulse width, <10% duty cycle)	$I_{F(TRAN)}$		1 80	A mA	<1 μ s Pulse Width, 300pps <1 μ s Pulse Width, <10%Duty Cycle
Reverse Input Voltage	V_R	-	5	V	
Input Power Dissipation	P_I		40	mW	
Output Power Dissipation	P_O		30	mW	
Lead Solder Temperature			260°C for 10 sec., 1.6 mm below seating plane		
Solder Reflow Temperature Profile			See Solder Reflow Temperature Profile Section		

Recommended Operating Conditions

Parameter	Symbol	Min.	Max.	Units
Ambient Operating Temperature	T_A	-40	+125	°C
Supply Voltages	V_{DD}	3.0	5.5	V
Forward Input Current	$I_{F(ON)}$	4.0	15	mA
Forward Off State Voltage	$V_{F(OFF)}$		0.8	V
Input Threshold Current	I_{TH}		3.5	mA

Electrical Specifications

Over recommended temperature ($T_A = -40^{\circ}\text{C}$ to $+125^{\circ}\text{C}$), $3.0\text{ V} \leq V_{DD} \leq 5.5\text{ V}$. All typical specifications are at $T_A = +25^{\circ}\text{C}$, $V_{DD} = +5\text{V}$.

Parameter	Symbol	Min.	Typ.	Max.	Units	Test Conditions	Fig
Input Capacitance	C_{IN}		90		pF		
Input Reverse Breakdown Voltage	BV_R	5.0			V	$I_R = 10\ \mu\text{A}$	
Logic High Output Voltage	V_{OH}	$V_{DD}-0.6$			V	$I_{OH} = -4\text{mA}$	4
Logic Low Output Voltage	V_{OL}			0.6	V	$I_{OL} = 4\text{mA}$	3
Logic Low Output Supply Current	I_{DDL}		0.9	1.5	mA		
Logic High Output Supply Current	I_{DDH}		0.9	1.5	mA		
LED Forward Voltage	V_f	1.45	1.5	1.75	V	$I_F = 10\text{mA}$, $T_A = 25^{\circ}\text{C}$	
		1.25	1.5	1.85	V	$I_F = 10\text{mA}$, $T_A = -40^{\circ}\text{C} \sim 125^{\circ}\text{C}$	
Vf Temperature Coefficient			-1.5		mV/ $^{\circ}\text{C}$		

ACPL-M71U High Speed Mode Switching Specifications

Over recommended temperature ($T_A = -40^{\circ}\text{C}$ to $+125^{\circ}\text{C}$), $4.5\text{ V} \leq V_{DD} \leq 5.5\text{ V}$. All typical specifications are at $T_A = +25^{\circ}\text{C}$, $V_{DD} = 5\text{V}$.

Parameter	Symbol	Min.	Typ.	Max.	Units	Test Conditions	Fig	Note
Propagation Delay Time to Logic Low Output ^[1]	t_{PHL}		26	35	ns	$V_{in} = 4.5\text{V}-5.5\text{V}$, $R_{in} = 390\Omega \pm 5\%$, $C_{in} = 100\text{pF}$, $C_L = 15\text{pF}$	5,6,11	1,2,3
Propagation Delay Time to Logic High Output ^[1]	t_{PLH}		26	35	ns			
Pulse Width Distortion ^[2]	PWD		0	12	ns			
Propagation Delay Skew ^[3]	t_{PSK}			15	ns			
Output Rise Time (10% – 90%)	t_R		10		ns			
Output Fall Time (90% - 10%)	t_F		10		ns			
Common Mode Transient Immunity at Logic High Output ^[4]	$ CM_H $	15	25		kV/ μs	$V_{in} = 0\text{V}$ $R_{in} = 390\Omega \pm 5\%$, $C_{in} = 100\text{pF}$, $V_{cm} = 1000\text{V}$, $T_A = 25^{\circ}\text{C}$	12	4
Common Mode Transient Immunity at Logic High Output ^[5]	$ CM_L $	15	25		kV/ μs	$V_{in} = 4.5\text{V}-5.5\text{V}$, $R_{in} = 390\Omega \pm 5\%$, $C_{in} = 100\text{pF}$, $V_{cm} = 1000\text{V}$, $T_A = 25^{\circ}\text{C}$	13	5

ACPL-M72U Low Power Mode Switching Specifications

Over recommended temperature (-40°C to +125°C), $3.0V \leq V_{DD} \leq 5.5V$. All typical specifications at +25°C and $V_{DD} = 5V$

Parameter	Symbol	Min.	Typ.	Max.	Units	Test Conditions	Fig	Note
Propagation Delay Time to Logic Low Output ^[1]	t_{PHL}		60	100	ns	$I_F=4mA, C_L=15pF$	7,8, 9,10, 14	1,2,3
Propagation Delay Time to Logic High Output ^[1]	t_{PLH}		35	100	ns			
Pulse Width Distortion ^[2]	PWD		25	50	ns			
Propagation Delay Skew ^[3]	t_{PSK}			60	ns			
Output Rise Time (10% – 90%)	t_R		10		ns			
Output Fall Time (90% - 10%)	t_F		10		ns			
Common Mode Transient Immunity at Logic High Output ^[4]	$ CM_H $	25	40		kV/ μs	Using Avago LED Driving Circuit, $V_{IN}=0V, R_1=350\Omega \pm 5\%, R_2=350\Omega \pm 5\%, V_{CM}=1000V, T_A=25^\circ C$	15	4
Common Mode Transient Immunity at Logic High Output ^[5]	$ CM_L $	25	40		kV/ μs	Using Avago LED Driving Circuit, $V_{IN}=4.5-5.5V, R_1=350\Omega \pm 5\%, R_2=350\Omega, V_{CM}=1000V, T_A=25^\circ C$	16	5

Package Characteristics

All Typical at $T_A = 25^\circ C$.

Parameter	Symbol	Min.	Typ.	Max.	Units	Test Conditions
Input-Output Momentary Withstand Voltage	V_{ISO}	3750			V_{rms}	$RH \leq 50\%, t = 1 \text{ min.}, T_A = 25^\circ C$
Input-Output Resistance	R_{I-O}		10^{14}		Ω	$V_{I-O} = 500 \text{ V dc}$
Input-Output Capacitance	C_{I-O}		0.6		pF	$f = 1 \text{ MHz}, T_A = 25^\circ C$

Notes:

- t_{PHL} propagation delay is measured from the 50% (V_{in} or I_f) on the rising edge of the input pulse to 0.8V on the falling edge of the V_O signal. t_{PLH} propagation delay is measured from the 50% (V_{in} or I_f) on the falling edge of the input pulse to the 80% level of the rising edge of the V_O signal.
- PWD is defined as $|t_{PHL} - t_{PLH}|$.
- t_{PSK} is equal to the magnitude of the worst case difference in t_{PHL} and/or t_{PLH} that will be seen between units at any given temperature within the recommended operating conditions.
- CM_H is the maximum tolerable rate of rise of the common mode voltage to assure that the output will remain in a high logic state.
- CM_L is the maximum tolerable rate of fall of the common mode voltage to assure that the output will remain in a low logic state.

Performance Plots

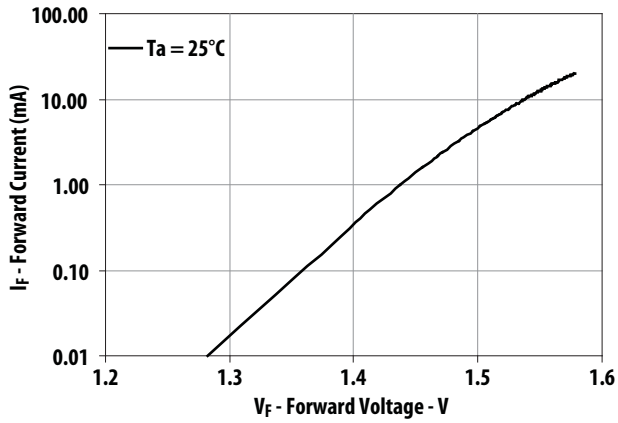

Figure 1. Typical Diode Input Forward Current Characteristic

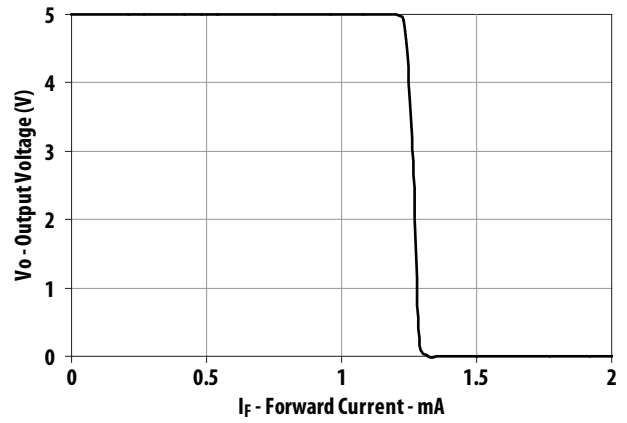

Figure 2. Typical Output Voltage vs Input Forward Current

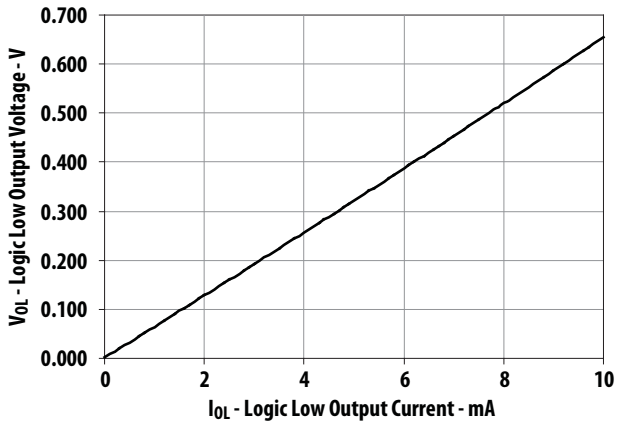

Figure 3. Typical Logic Low Output Voltage vs Logic Low Output Current

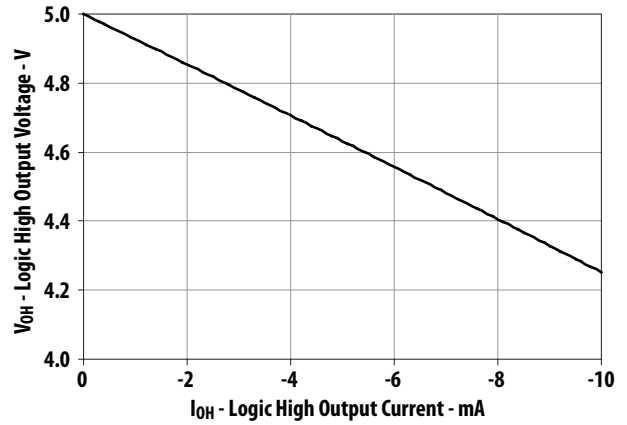

Figure 4. Typical Logic High Output Voltage vs Logic High Output Current

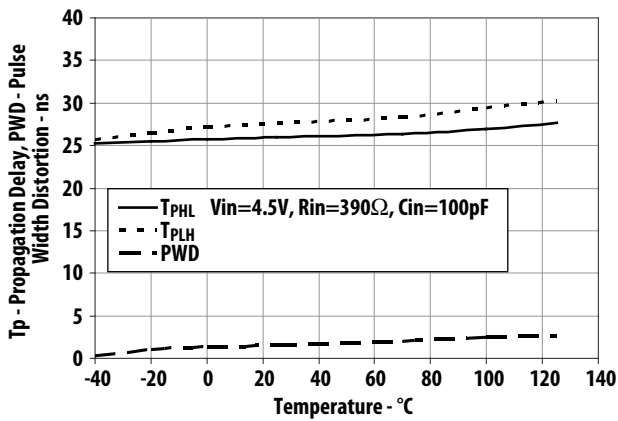

Figure 5. ACPL-M71U (High Speed) Typical Propagation Delay vs Temperature

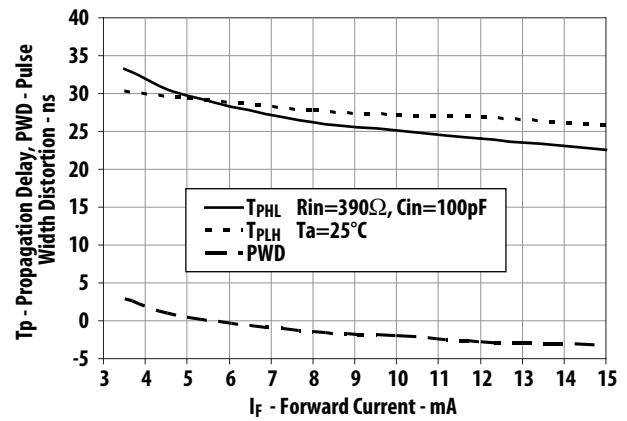

Figure 6. ACPL-M71U (High Speed) Typical Propagation Delay vs Forward Current - I_f

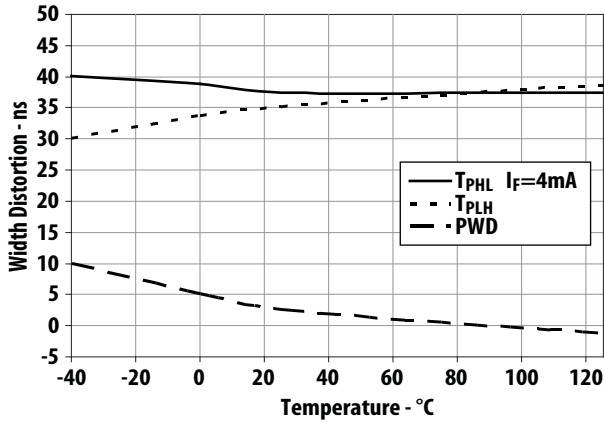

Figure 7. ACPL-M72U (5V) Typical Propagation Delay vs Temperature

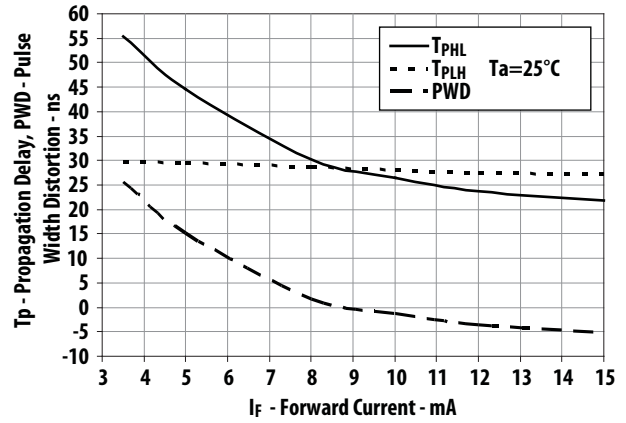

Figure 8. ACPL-M72U (5V) Typical Propagation Delay vs Forward Current - I_F

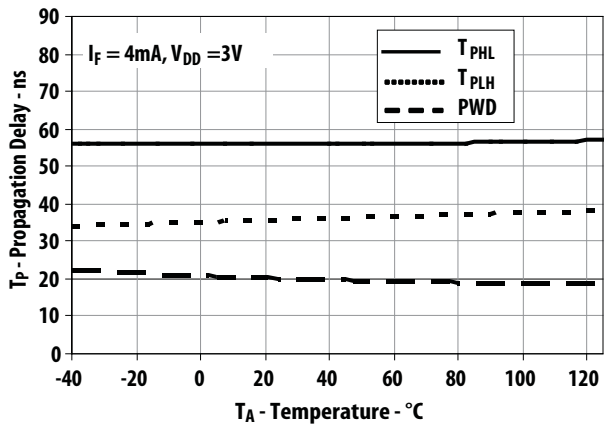

Figure 9. ACPL-M72U (3V) Typical Propagation Delay vs Temperature

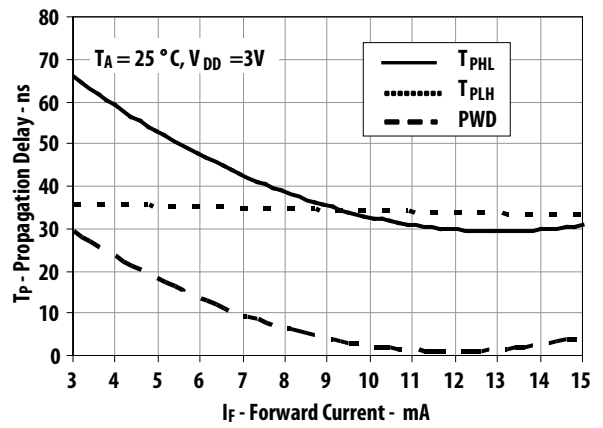

Figure 10. ACPL-M72U (3V) Typical Propagation Delay vs Input Forward Current

Test Circuit Diagrams

ACPL-M71U High Speed Mode:

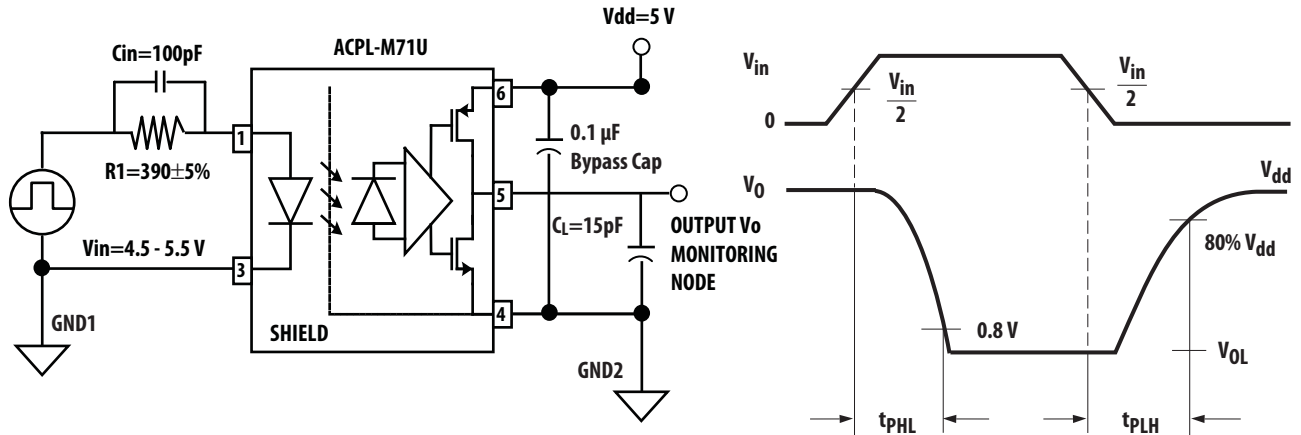

Figure 11. High Speed Mode Test Circuit and Typical Waveform

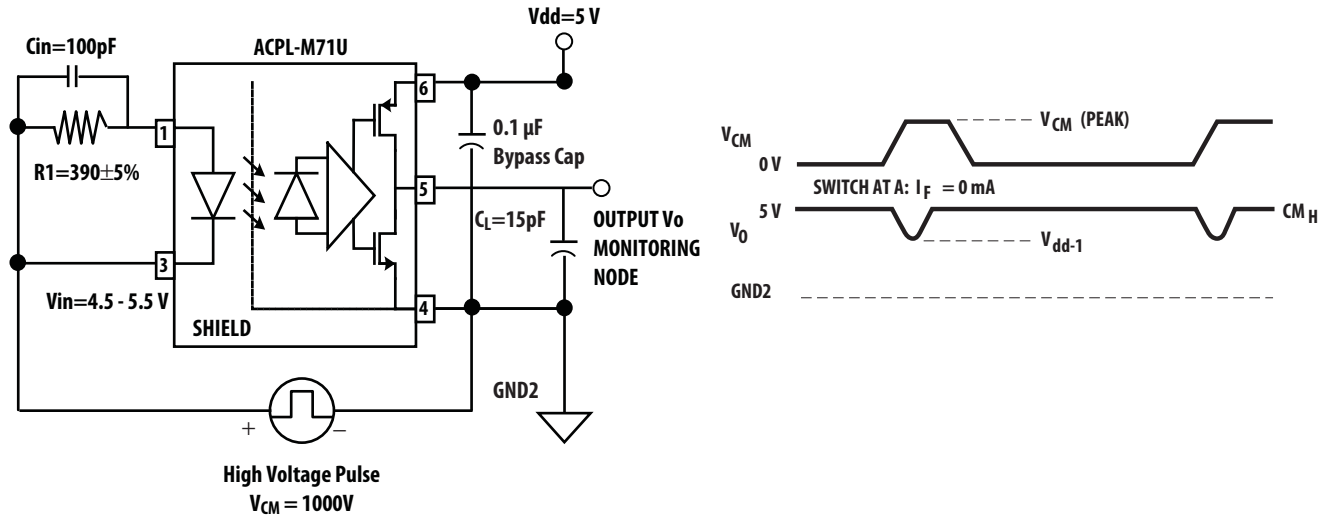

Figure 12. High Speed Mode CMH Test Circuit and Typical Waveform

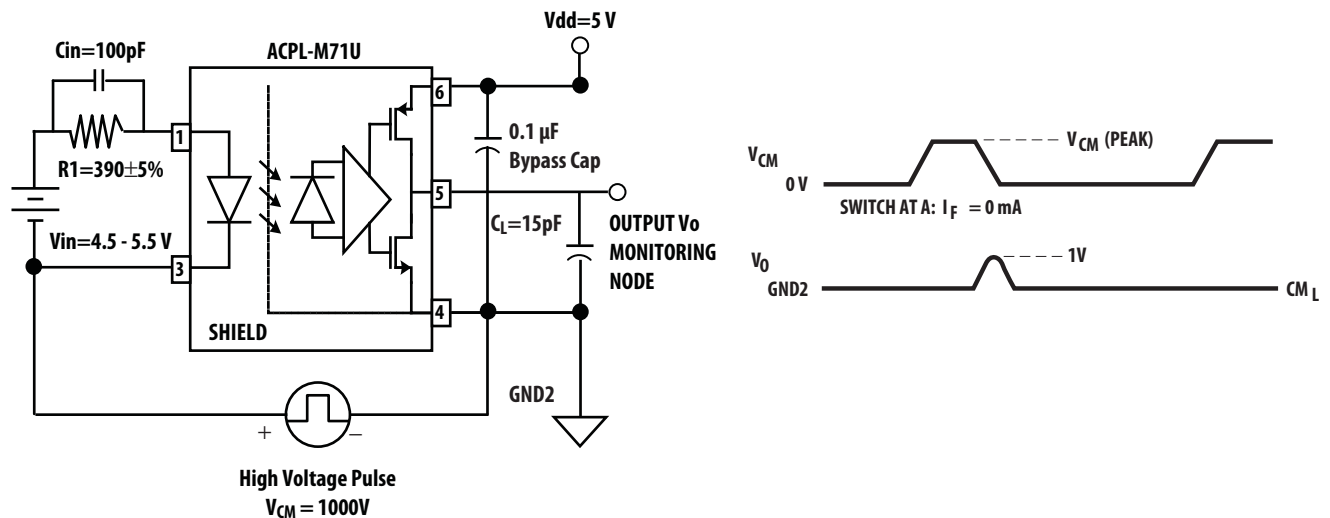

Figure 13. High Speed Mode CML Test Circuit and Typical Waveform

ACPL-M72U Low Power Mode:

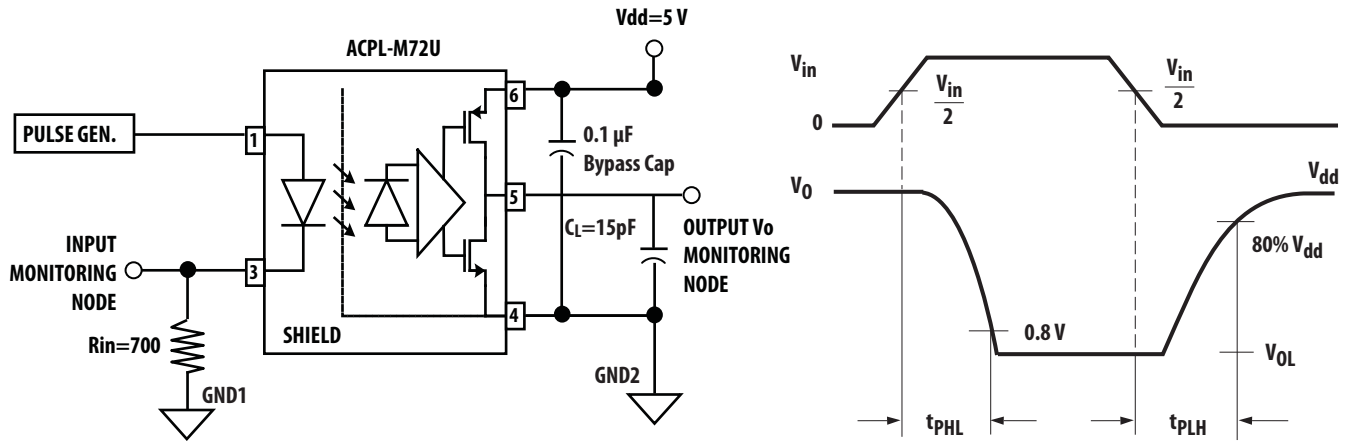

Figure 14. Low Power Mode Switching Test Circuit and Typical Waveform

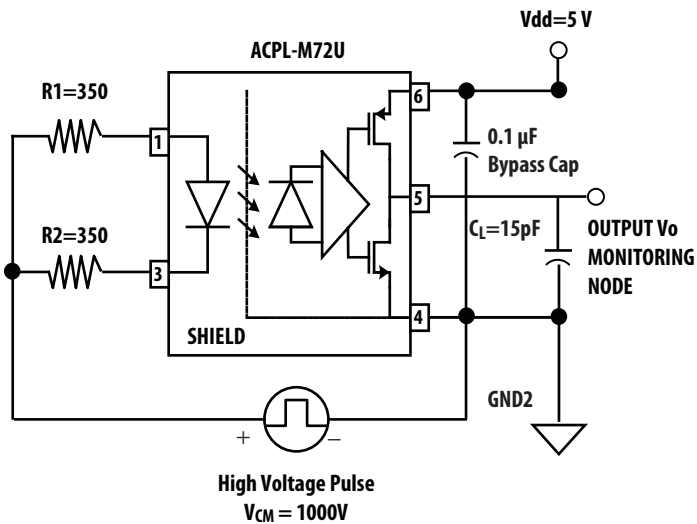

Figure 15. Low Power Mode High CMR, CMH Test Circuit

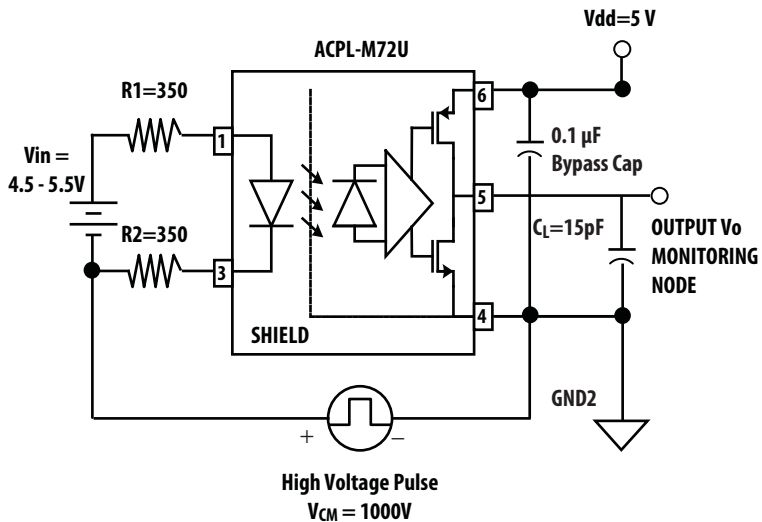
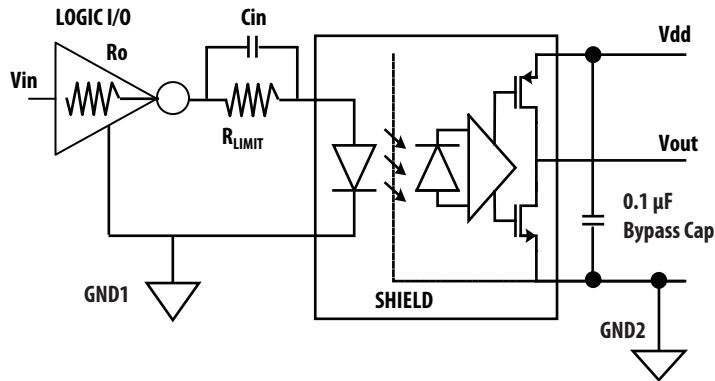

Figure 16. Low Power Mode High CMR, CML Test Circuit

Application Circuits



Truth Table

Vin	LED	Vout
L	ON	L
H	OFF	H

Figure 17. Recommended Application Circuit for ACPL-M71U High Speed Performance

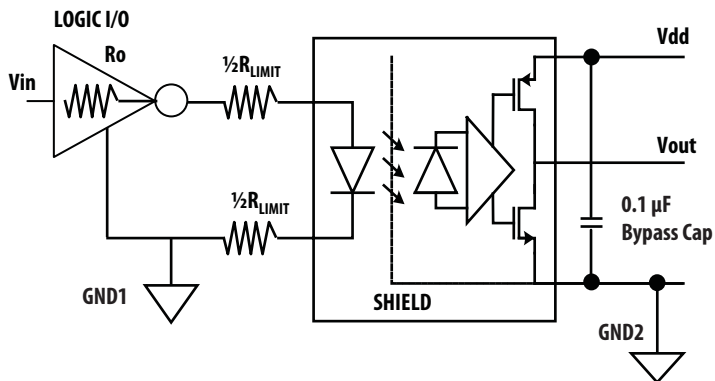

Truth Table

Vin	LED	Vout
L	ON	L
H	OFF	H

Figure 18. Recommended Application Circuit for ACPL-M72U Low Power Performance

For product information and a complete list of distributors, please go to our web site: www.avagotech.com

Avago, Avago Technologies, the A logo and R²Coupler™ are trademarks of Avago Technologies in the United States and other countries. Data subject to change. Copyright © 2005-2012 Avago Technologies. All rights reserved. AV02-3712EN - October 5, 2012

AVAGO
TECHNOLOGIES

Mouser Electronics

Authorized Distributor

Click to View Pricing, Inventory, Delivery & Lifecycle Information:

[Broadcom Limited:](#)

[ACPL-M72U-500E](#) [ACPL-M71U-500E](#) [ACPL-M72U-000E](#) [ACPL-M71U-000E](#)