

# JBC

[www.jbctools.com](http://www.jbctools.com)

## INSTRUCTION MANUAL



### MS

Electric Desoldering Module  
for DIU & CDD

This manual corresponds to the following reference:

**MS-A**

## Packing List

The following items are included:



**Electric Desoldering Module** .....1 unit



**Module Cable connector** .....1 unit  
Ref. 0026830



**Suction Filter** .....1 unit  
Ref. 0821830



**Paper Filters Box** .....1 unit  
Ref. 0005966  
*Ref. contains 50 filters*



**Cotton Filter Set** ..... 1 unit  
Ref. 0781046  
*Ref. contains 10 filters*



**Manual** .....1 unit  
Ref. 0027989

## Features and Connections

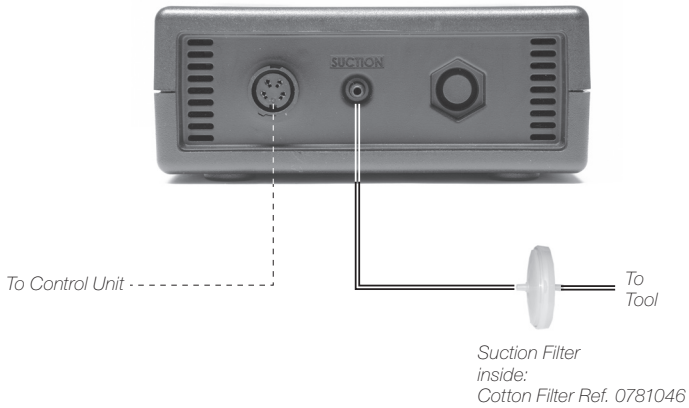

## Compatibility

Select the equipment that best suits your soldering or desoldering needs.

Module	Stand	Tool	Tips Range	Control Units	
				CDD	DIU
MS	DSS	DS360	C360	●	●
	DRS	DR560	C560		●

## Maintenance

- Before carrying out maintenance or storage, always unplug the equipment.
- Keep the casing clean by using a damp cloth. Specially use a soft cloth for the front side.
- Periodically check all cable and tube connections.
- Keep filters clean to ensure proper solder suction and replace them when necessary.

**Important:** Do not use sharp pointed objects to open the suction filter.

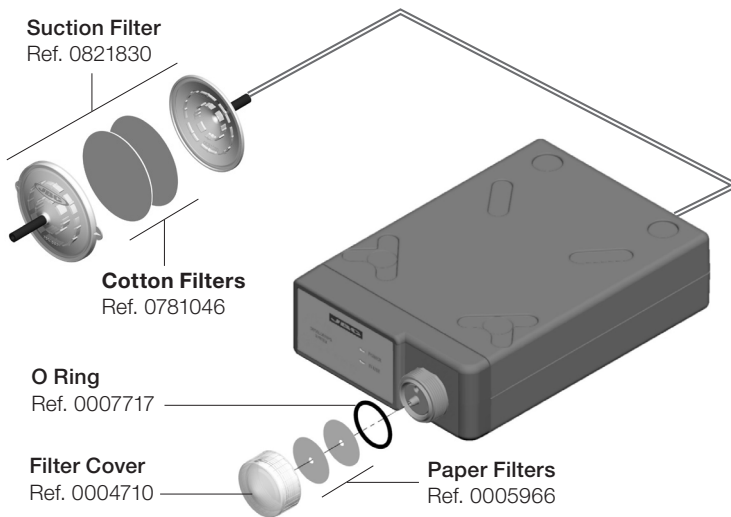

- Use original JBC spare parts only
- Replace any defective or damaged pieces. Only use original JBC spare parts.
- Repairs should only be performed by a JBC authorized technical service.
- Maintenance must not be carried out by children unless supervised.

## Safety



**It is imperative to follow safety guidelines to prevent electric shock, injury, fire or explosion.**

- Do not use the units for any purpose other than soldering or rework. Incorrect use may cause fire.
- The power cord must be plugged into approved bases. Be sure that it is properly grounded before use. When unplugging it, hold the plug, not the wire.
- Do not work on electrically live parts.
- The tool should be placed in the stand when not in use in order to activate the sleep mode. The soldering tip or nozzle, the metal part of the tool and the stand may still be hot even when the station is turned off. Handle with care, including when adjusting the stand position.
- Do not leave the appliance unattended when it is on.
- Do not cover the ventilation grills. Heat can cause inflammable products to ignite.
- Avoid flux coming into contact with skin or eyes to prevent irritation.
- Be careful with the fumes produced when soldering.
- Keep your workplace clean and tidy. Wear appropriate protection glasses and gloves when working to avoid personal harm.
- Utmost care must be taken with liquid tin waste which can cause burns.
- This appliance can be used by children over the age of eight and also persons with reduced physical, sensory or mental capabilities or lack of experience provided that they have been given adequate supervision or instruction concerning use of the appliance and understand the hazards involved. Children must not play with the appliance.
- Maintenance must not be carried out by children unless supervised.





# Specifications

## MS

### Electric Desoldering Module for DIU & CDD

Ref.: **MS-A**

- Net Weight: 1.19 kg / 2.62 lb
- Module Dimension (L x W x H): 225 x 145 x 55 mm / 8.86 x 5.71 x 2.17 x in
- Vacuum: 75% / 570 mmHg / 22.4 inHg
- Flow Rate: 9 SLPM
- Ambient Operating Temperature: 10 - 40 °C / 50 - 104 °F
  
- Total Package Dimensions / Weight: 280 x 195 x 115 mm / 1.50 kg  
(L x W x H) 11.02 x 7.68 x 4.53 / 3.30 lb

Complies with CE standards.  
ESD safe.

# JBC

## Warranty

JBC's 2 year warranty covers this equipment against all manufacturing defects, including the replacement of defective parts and labour.

Warranty does not cover product wear or misuse.

In order for the warranty to be valid, equipment must be returned, postage paid, to the dealer where it was purchased.



This product should not be thrown in the garbage.

In accordance with the European directive 2012/19/EU, electronic equipment at the end of its life must be collected and returned to an authorized recycling facility.

